



**THE DATASHEET OF
AP1120SBL-13**



OBSOLETE - PART DISCONTINUED

Features

- 1.3V maximum dropout at full load current
- Fast transient response
- Output current limiting for each channel
- Built-in thermal shutdown each channel
- Good noise rejection
- Dual output ch1=3.3V, ch2=2.5V (1.8V for B version)
- Lead Free Package: SOP-8L
- Lead Free Finish/ RoHS Compliant (Note 1)

General Description

AP1120 series are low dropout positive regulator to provide 1A output current capability. The product is specifically designed to provide well-regulated supply for low voltage IC applications such as high-speed bus termination and low current 3.3V/2.5V or 3.3V/1.8V logic supply. AP1120 series are guaranteed to have <1.3V dropout at full load current making it ideal to provide well regulated outputs dual channels with up to 18V input supply.

Applications

- PC peripheral
- Communication

Ordering Information

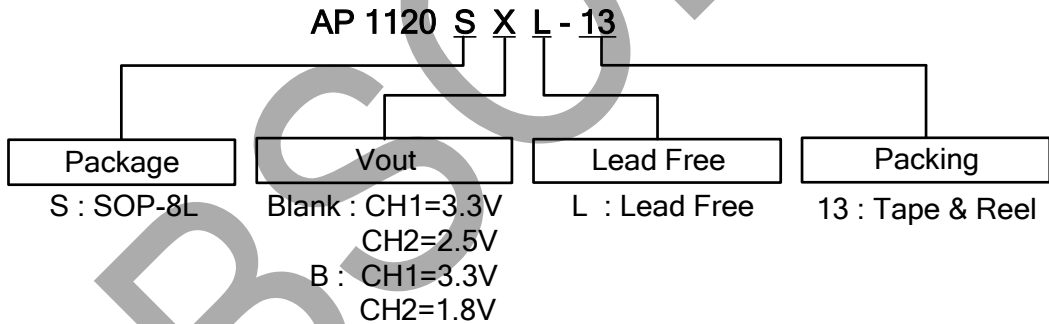

Device	Package Code	Packaging (Note 2)	13" Tape and Reel	
			Quantity	Part Number Suffix
AP1120SXL-13	S	SOP-8L	2500/Tape & Reel	-13

Notes: 1. EU Directive 2002/95/EC (RoHS). All applicable RoHS exemptions applied. Please visit our website at http://www.diodes.com/products/lead_free.html.
 2. Pad layout as shown on Diodes Inc. suggested pad layout document AP02001, which can be found on our website at <http://www.diodes.com/datasheets/ap02001.pdf>.

Pin Assignments

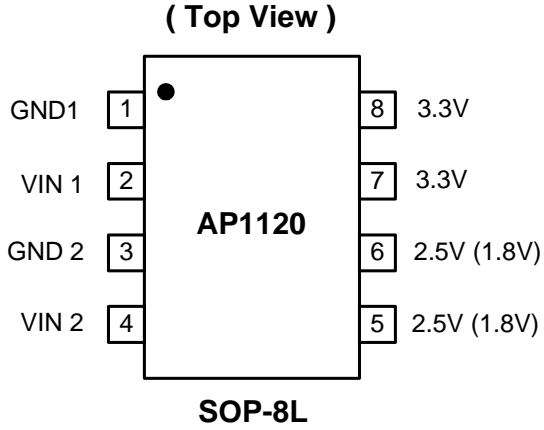

Pin Descriptions

Pin Name	Description
GND1/2	Ground
3.3V (Vout1)	The output of the regulator. A minimum of 10uF capacitor ($0.15\Omega \leq ESR \leq 20\Omega$) must be connected from this pin to ground to insure stability.
2.5V/1.8V (Vout2)	
VIN1/2	The input pin of regulator. Typically a large storage capacitor ($0.15\Omega \leq ESR \leq 20\Omega$) is connected from this pin to ground.

OBSOLETE - PART DISCONTINUED

Block Diagram

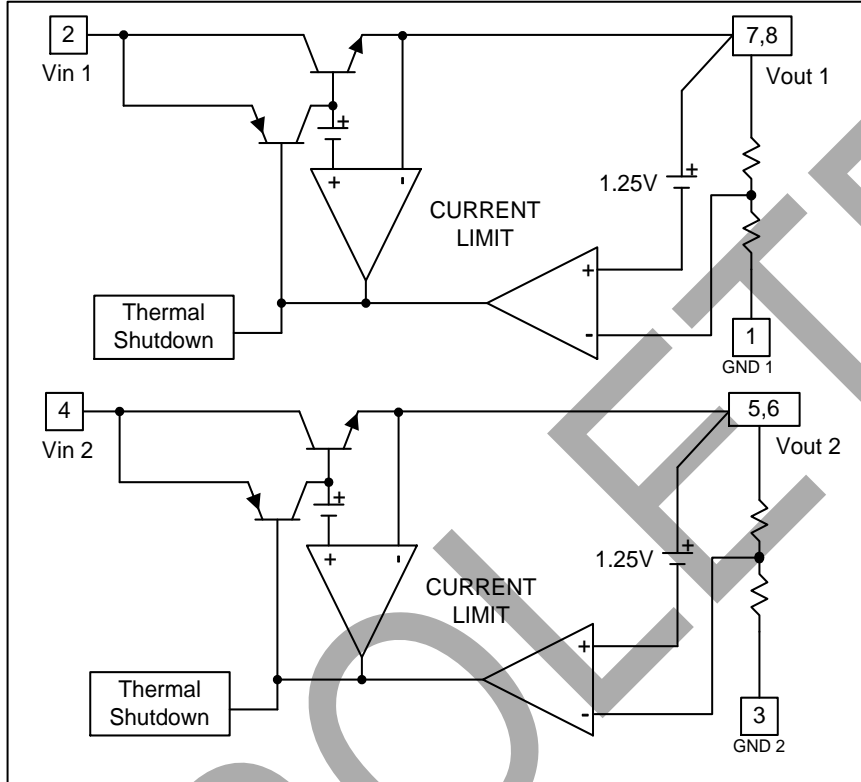

Typical Circuit

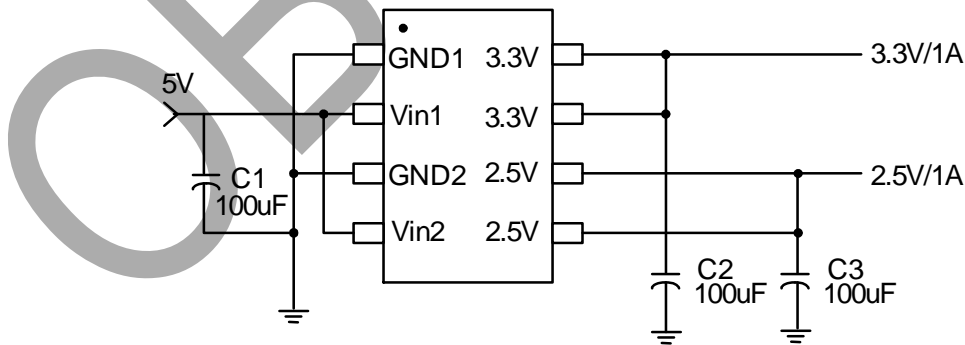

(3.3V/2.5V Dual output)

OBSOLETE - PART DISCONTINUED

Absolute Maximum Ratings

Symbol	Parameter	Rating	Unit
V_{IN}	DC Supply Voltage	-0.3 to 18 V	V
P_D	Power Dissipation	Internally Limited	
T_{ST}	Storage Temperature	-65 to +150	°C
T_{OP}	Operating Junction Temperature Range	0 to +150	°C

Electrical Characteristics (Under Operating Conditions)

Parameter	Conditions	Min	Typ.	Max	Unit
Output Voltage	AP1120(B) - V_{OUT1} $I_{OUT} = 10mA, T_A = 25^\circ C, 4.8V \leq V_{IN} \leq 12V$	3.235	3.300	3.365	V
	AP1120 - V_{OUT2} $I_{OUT} = 10mA, T_A = 25^\circ C, 4V \leq V_{IN} \leq 12V$	2.450	2.500	2.550	V
	AP1120B - V_{OUT2} $I_{OUT} = 10mA, T_A = 25^\circ C, 4V \leq V_{IN} \leq 12V$	1.764	1.800	1.836	V
Line Regulation	$I_O = 10mA, V_{OUT} + 1.5V < V_{IN} < 12V, T_A = 25^\circ C$			0.2	%
Load Regulation	AP1120 series V_{OUT1} $V_{IN} = 5V, 0 \leq I_{OUT} \leq 1A, T_A = 25^\circ C$ (Note 3, 4)		26	33	mV
	AP1120 series V_{OUT2} $V_{IN} = 4V, 0mA < I_O < 1A, T_A = 25^\circ C$ (Note 3, 4)		20	25	mV
Dropout Voltage ($V_{IN} - V_{OUT}$)	$I_{OUT} = 1A, \Delta V_{OUT} = 0.1\% V_{OUT}$		1.3	1.4	V
Current Limit	$(V_{IN} - V_{OUT}) = 5V$	1.1			A
Minimum Load Current	$0^\circ C \leq T_J \leq 125^\circ C$ (Note 5)		5	10	mA
Thermal Regulation	$T_A = 25^\circ C, 30ms$ pulse		0.008	0.04	%/W
Ripple Rejection	$F = 120Hz, C_{OUT} = 25\mu F$ Tantalum, $I_{OUT} = 1A$		60	70	dB
Temperature Stability	$I_O = 10mA$		0.5		%
θ_{JA} Thermal Resistance Junction-to-Ambient (No heat sink; No air flow)	SOP-8L: Control Circuitry/Power Transistor (Note 6) CH1 or CH2 only CH1 & CH2 and PD1=PD2		50 45		°C/W
θ_{JC} Thermal Resistance Junction-to-Case	SOP-8L: Control Circuitry/Power Transistor (Note 6) CH1 or CH2 only CH1 & CH2 and PD1=PD2		20 12		°C/W

- Notes:
- See thermal regulation specifications for changes in output voltage due to heating effects. Line and load regulation are measured at a constant junction temperature by low duty cycle pulse testing. Load regulation is measured at the output lead = 1/18" from the package.
 - Line and load regulation are guaranteed up to the maximum power dissipation of 15W. Power dissipation is determined by the input/output differentially and the output current. Guaranteed maximum power dissipation will not be available over the full input/output range.
 - Quiescent current is defined as the minimum output current that requires maintaining regulation. At 12V input/output differential the device is guaranteed to regulate if the output current is greater than 10mA.
 - V_{out1} and V_{out2} are connected to the PCB copper area 5.5mm*5.5mm separately. If you need large PD or lower T_c & T_J , please connect to the large copper area >> 5.5mm*5.5mm (like 10mm*10mm).

Typical Performance Characteristics

OBSELETE - PART DISCONTINUED

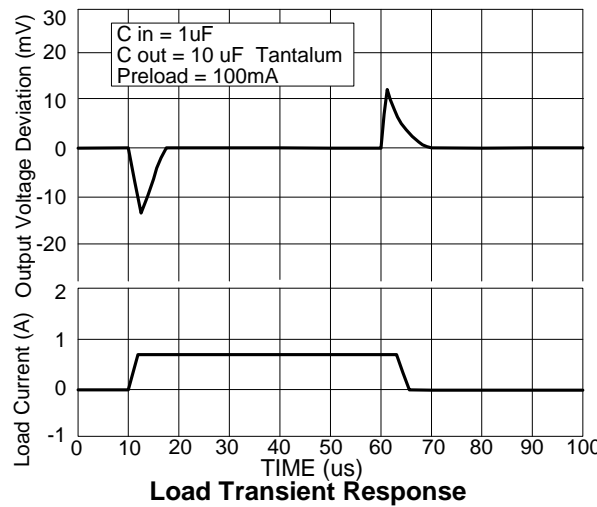
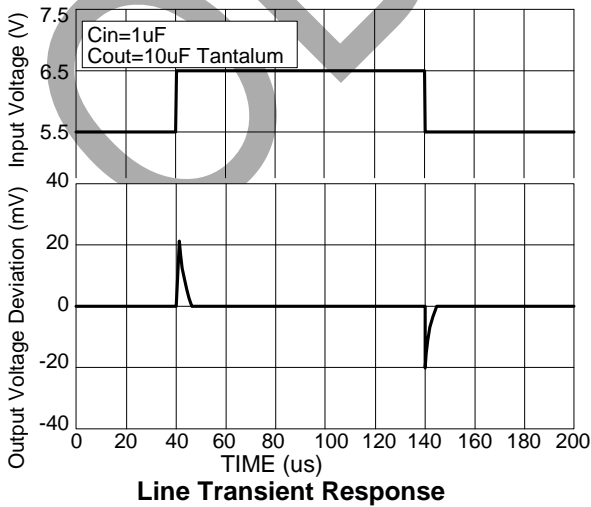
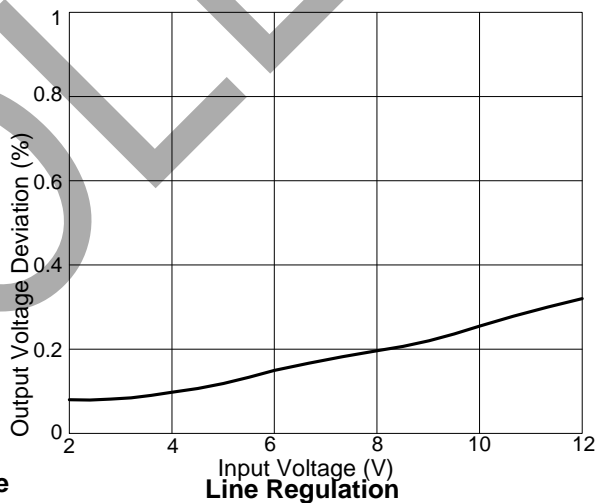
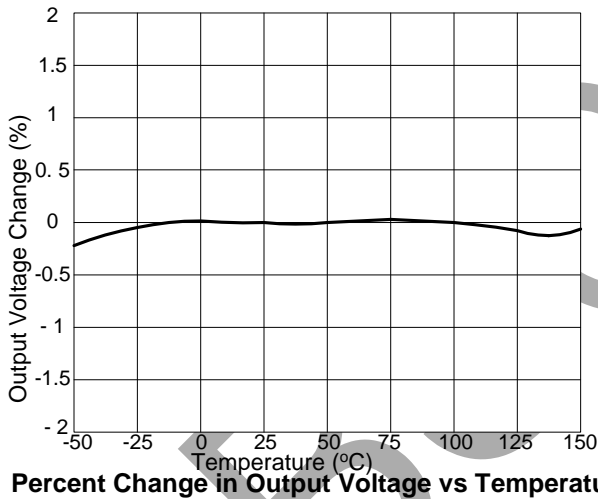
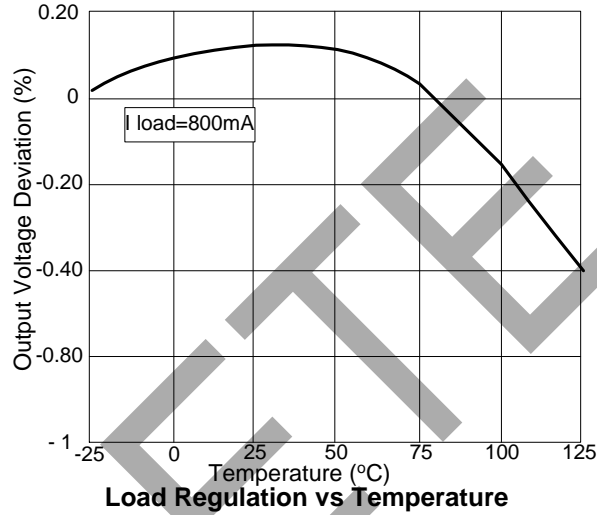
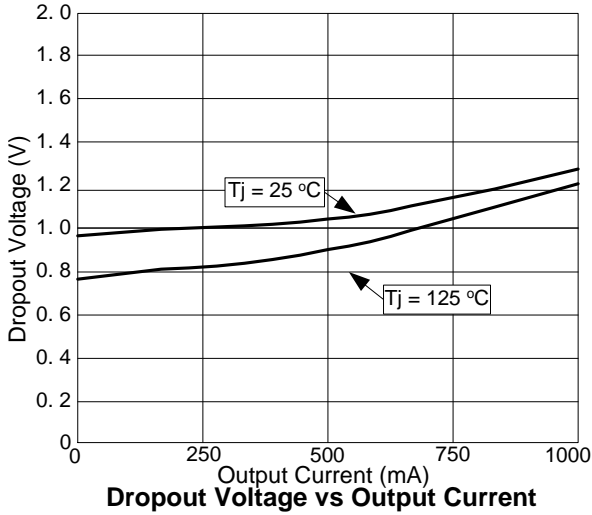

PART OBSOLETE



AP1120

DUAL 1A LOW DROPOUT POSITIVE REGULATOR

Marking Information

(1) SOP-8L

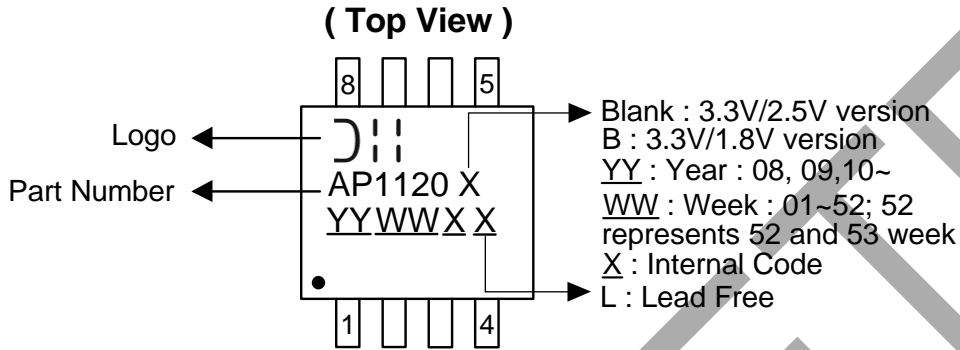

Package Information (All Dimensions in mm)

(1) Package type: SOP-8L

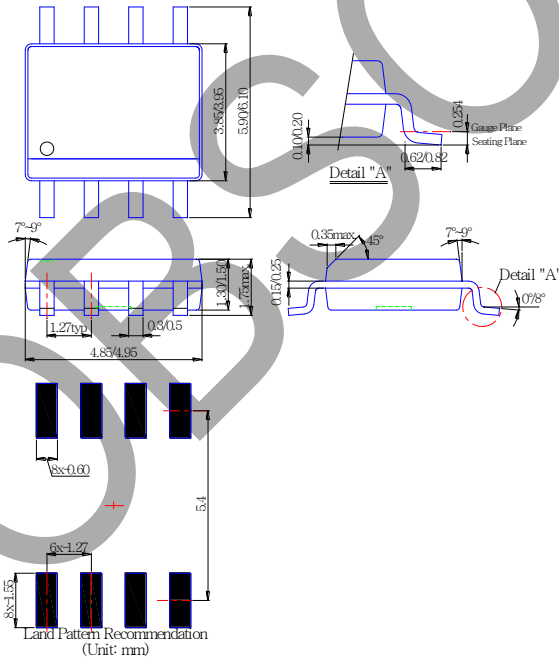

OBSOLETE - PART DISCONTINUED

IMPORTANT NOTICE

DIODES INCORPORATED MAKES NO WARRANTY OF ANY KIND, EXPRESS OR IMPLIED, WITH REGARDS TO THIS DOCUMENT, INCLUDING, BUT NOT LIMITED TO, THE IMPLIED WARRANTIES OF MERCHANTABILITY AND FITNESS FOR A PARTICULAR PURPOSE (AND THEIR EQUIVALENTS UNDER THE LAWS OF ANY JURISDICTION).

Diodes Incorporated and its subsidiaries reserve the right to make modifications, enhancements, improvements, corrections or other changes without further notice to this document and any product described herein. Diodes Incorporated does not assume any liability arising out of the application or use of this document or any product described herein; neither does Diodes Incorporated convey any license under its patent or trademark rights, nor the rights of others. Any Customer or user of this document or products described herein in such applications shall assume all risks of such use and will agree to hold Diodes Incorporated and all the companies whose products are represented on Diodes Incorporated website, harmless against all damages.

Diodes Incorporated does not warrant or accept any liability whatsoever in respect of any products purchased through unauthorized sales channel. Should Customers purchase or use Diodes Incorporated products for any unintended or unauthorized application, Customers shall indemnify and hold Diodes Incorporated and its representatives harmless against all claims, damages, expenses, and attorney fees arising out of, directly or indirectly, any claim of personal injury or death associated with such unintended or unauthorized application.

Products described herein may be covered by one or more United States, international or foreign patents pending. Product names and markings noted herein may also be covered by one or more United States, international or foreign trademarks.

This document is written in English but may be translated into multiple languages for reference. Only the English version of this document is the final and determinative format released by Diodes Incorporated.

LIFE SUPPORT

Diodes Incorporated products are specifically not authorized for use as critical components in life support devices or systems without the express written approval of the Chief Executive Officer of Diodes Incorporated. As used herein:

- A. Life support devices or systems are devices or systems which:
1. are intended to implant into the body, or
 2. support or sustain life and whose failure to perform when properly used in accordance with instructions for use provided in the labeling can be reasonably expected to result in significant injury to the user.
- B. A critical component is any component in a life support device or system whose failure to perform can be reasonably expected to cause the failure of the life support device or to affect its safety or effectiveness.



Customers represent that they have all necessary expertise in the safety and regulatory ramifications of their life support devices or systems, and acknowledge and agree that they are solely responsible for all legal, regulatory and safety-related requirements concerning their products and any use of Diodes Incorporated products in such safety-critical, life support devices or systems, notwithstanding any devices- or systems-related information or support that may be provided by Diodes Incorporated. Further, Customers must fully indemnify Diodes Incorporated and its representatives against any damages arising out of the use of Diodes Incorporated products in such safety-critical, life support devices or systems.

Copyright © 2015, Diodes Incorporated

www.diodes.com

Looking for pricing, stock, or lifecycle information?

Click below to explore more details on WIN SOURCE:

-  [View AP1120SBL-13 on WIN SOURCE](#)
-  [Diodes Incorporated Information](#)

Optimize Your Supply Chain with WIN SOURCE Solutions

-  Global Sourcing Solution
-  Obsolete Management
-  Cost Control Management
-  Shortage Management
-  Alternative Solution
-  Excess Inventory Management