



**THE DATASHEET OF
MJ10009**





ELECTRONICS, INC.
 44 FARRAND STREET
 BLOOMFIELD, NJ 07003
 (973) 748-5089
<http://www.nteinc.com>

MJ10009 Silicon NPN Transistor HV Darlington Power Amp, Switch TO-3 Type Package

Description:

The MJ10009 is a silicon NPN Darlington transistor in a TO-3 type package designed for high voltage, high-speed, power switching in inductive circuits where fall-time is critical. They are particularly suited for line operated switch-mode applications.

Applications:

- Switching Regulators
- Inverters
- Solenoid and Relay Drivers

Absolute Maximum Ratings:

Collector-Emitter Voltage, $V_{CEO(sus)}$	500V
Collector-Emitter Voltage, $V_{CEX(sus)}$	500V
Collector-Emitter Voltage, V_{CEV}	700V
Emitter-Base Voltage, V_{EB}	8V
Collector Current, I_C	
Continuous	20A
Peak (Note 1)	30A
Base Current, I_B	
Continuous	2.5A
Peak (Note 1)	5.0A
Total Power Dissipation ($T_C = +25^\circ C$), P_D	175W
Derate Above $+25^\circ C$	1.0W/ $^\circ C$
Total Power Dissipation ($T_C = +100^\circ C$), P_D	100W
Operating Junction Temperature Range, T_J	-65° to $+200^\circ C$
Storage Temperature Range, T_{stg}	-65° to $+200^\circ C$
Thermal Resistance, Junction-to-Case, R_{thJC}	1.0 $^\circ C/W$
Lead Temperature (During Soldering, 1/8" from case, 5sec), T_L	$+275^\circ C$

Note 1. Pulse test: Pulse Width = 5ms, Duty Cycle \leq 10%.

Electrical Characteristics: ($T_C = +25^\circ\text{C}$ unless otherwise specified)

Parameter	Symbol	Test Conditions	Min	Typ	Max	Unit
OFF Characteristics (Note 2)						
Collector–Emitter Sustaining Voltage	$V_{\text{CEO(sus)}}$	$I_C = 100\text{mA}, I_B = 0, V_{\text{clamp}} = 500\text{V}$	500	–	–	V
	$V_{\text{CEX(sus)}}$	$I_C = 2\text{A}, V_{\text{clamp}} = 500\text{V}, T_C = +100^\circ\text{C}$	500	–	–	V
		$I_C = 5\text{A}, V_{\text{clamp}} = 500\text{V}, T_C = +100^\circ\text{C}$	375	–	–	V
Collector Cutoff Current	I_{CEV}	$V_{\text{CEV}} = 700\text{V}, V_{\text{BE(off)}} = 1.5\text{V}$	–	–	0.25	mA
		$V_{\text{CEV}} = 700\text{V}, V_{\text{BE(off)}} = 1.5\text{V}, T_C = +150^\circ\text{C}$	–	–	5.0	mA
	I_{CER}	$V_{\text{CE}} = 700\text{V}, R_{\text{BE}} = 50\Omega, T_C = +100^\circ\text{C}$	–	–	5.0	mA
Emitter Cutoff Current	I_{EBO}	$V_{\text{EB}} = 2\text{V}, I_C = 0$	–	–	175	mA
ON Characteristics (Note 3)						
DC Current Gain	h_{FE}	$V_{\text{CE}} = 5\text{V}, I_C = 5\text{A}$	40	–	400	
		$V_{\text{CE}} = 5\text{V}, I_C = 10\text{A}$	30	–	300	
Collector–Emitter Saturation Voltage	$V_{\text{CE(sat)}}$	$I_C = 10\text{A}, I_B = 500\text{mA}$	–	–	2.0	V
		$I_C = 10\text{A}, I_B = 500\text{mA}, T_C = +100^\circ\text{C}$	–	–	2.5	V
		$I_C = 20\text{A}, I_B = 2\text{A}$	–	–	3.5	V
Base–Emitter Saturation Voltage	$V_{\text{BE(sat)}}$	$I_C = 10\text{A}, I_B = 500\text{mA}$	–	–	2.5	V
		$I_C = 10\text{A}, I_B = 500\text{mA}, T_C = +100^\circ\text{C}$	–	–	2.5	V
Diode Forward Voltage	V_{F}	$I_{\text{F}} = 5\text{A}, \text{Note 3}$	–	3	5	V
Dynamic Characteristics						
Small–Signal Current Gain	h_{fe}	$V_{\text{CE}} = 10\text{V}, I_C = 1\text{A}, f_{\text{test}} = 1\text{MHz}$	8	–	–	
Output Capacitance	C_{ob}	$V_{\text{CB}} = 50\text{V}, I_{\text{E}} = 0, f_{\text{test}} = 100\text{kHz}$	100	–	325	pF
Switching Characteristics (Resistive Load)						
Delay Time	t_{d}	$V_{\text{CC}} = 250\text{V}, I_C = 10\text{A}, I_{\text{B1}} = 500\text{mA}, V_{\text{BE(off)}} = 5\text{V}, t_{\text{p}} = 50\mu\text{s}, \text{Duty Cycle} \leq 2\%$	–	0.12	0.25	μs
Rise Time	t_{r}		–	0.5	1.5	μs
Storage Time	t_{s}		–	0.8	2.0	μs
Fall Time	t_{f}		–	0.2	0.6	μs
Switching Characteristics (Inductive Load, Clamped)						
Storage Time	t_{sv}	$I_C = 10\text{A Peak}, V_{\text{clamp}} = 250\text{V}, I_{\text{B1}} = 500\text{mA}, V_{\text{BE(off)}} = 5\text{V}, T_C = +100^\circ\text{C}$	–	1.5	3.5	μs
Crossover Time	t_{c}		–	0.36	1.6	μs
Storage Time	t_{sv}	$I_C = 10\text{A Peak}, V_{\text{clamp}} = 250\text{V}, I_{\text{B1}} = 500\text{mA}, V_{\text{BE(off)}} = 5\text{V}, T_C = +25^\circ\text{C}$	–	0.8	–	μs
Crossover Time	t_{c}		–	0.18	–	μs

Note 2. Pulse test: Pulse Width = $300\mu\text{s}$, Duty Cycle $\leq 2\%$.

Note 3. The internal Collector–Emitter diode can eliminate the need for an external diode to clamp inductive loads. Tests have shown that the Forward Recovery Voltage (V_{F}) of this diode is comparable to that of typical fast recovery rectifiers.

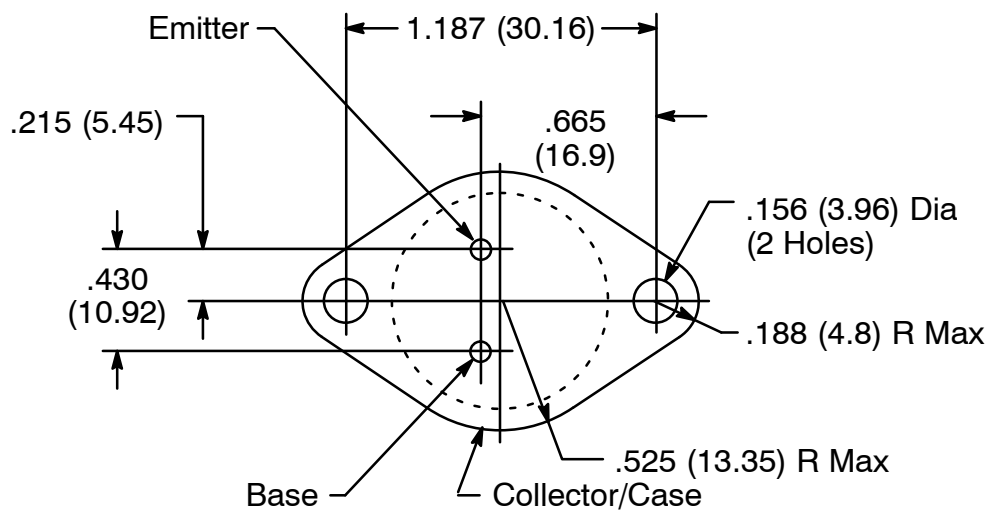
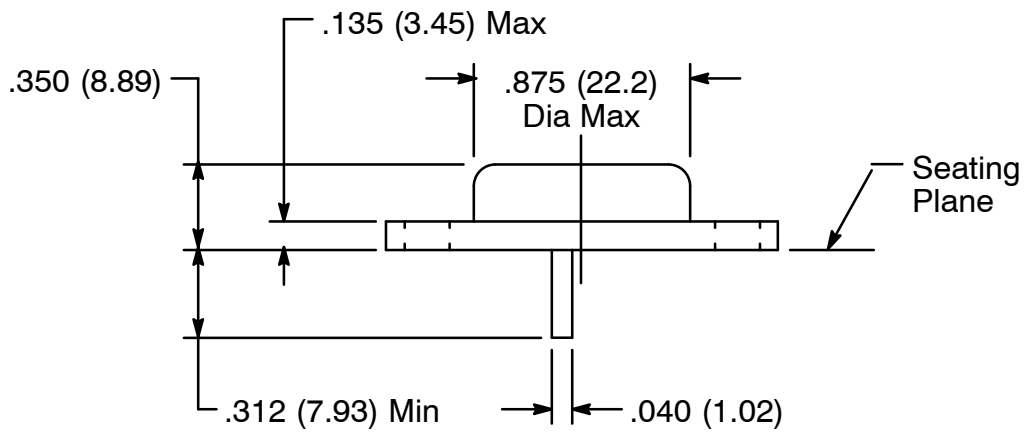
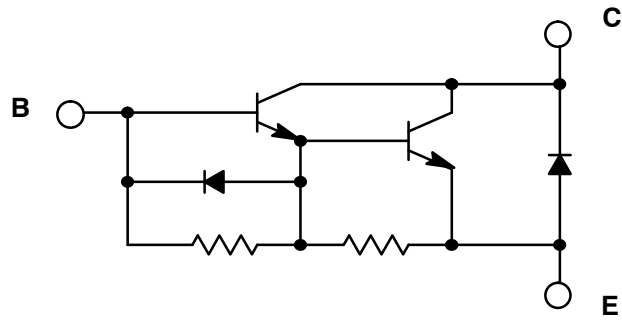

Looking for pricing, stock, or lifecycle information?

Click below to explore more details on WIN SOURCE:

 [View MJ10009 on WIN SOURCE](#)

 [NTE Information](#)

Optimize Your Supply Chain with WIN SOURCE Solutions

-  Global Sourcing Solution
-  Obsolete Management
-  Cost Control Management
-  Shortage Management
-  Alternative Solution
-  Excess Inventory Management