



**THE DATASHEET OF
SN74BCT374NSR**



SNx4BCT374 Octal Edge-Triggered D-Type Latches With 3-State Outputs

1 Features

- Operating Voltage Range of 4.5 V to 5.5 V
- BiCMOS Design Significantly Reduces I_{CCZ} Over TTL Designs
- Full Parallel Access for Loading
- Buffered Control Inputs
- 3-State Outputs Drive Bus Lines or Buffer Memory Address Registers

2 Applications

- Buffer Registers
- I/O Ports
- Bus Drivers
- Working Registers

3 Description

The SNx4BCT374 devices contain eight channels of D-type flip-flops with a shared clock (CLK) and output enable (\overline{OE}) pin.

Device Information (1)

PART NUMBER	PACKAGE	BODY SIZE (NOM)
SN74BCT374N	PDIP (20)	25.40 mm × 6.35 mm
SN74BCT374DW	SOIC (20)	12.80 mm × 7.50 mm
SN74BCT374NS	SOP (20)	12.60 mm × 5.30 mm
SN74BCT374DB	SSOP (20)	7.20 mm × 5.30 mm
SN54BCT374J	CDIP (20)	26.92 mm × 6.92 mm
SN54BCT374W	CFP (20)	13.72 mm × 6.92 mm
SN54BCT374FK	LCCC (20)	8.89 mm × 8.89 mm

(1) For all available packages, see the orderable addendum at the end of the data sheet.

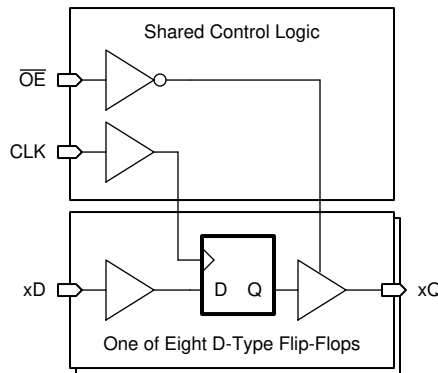

Functional Block Diagram



Table of Contents

1 Features	1	8.3 Feature Description.....	8
2 Applications	1	8.4 Device Functional Modes.....	9
3 Description	1	9 Application and Implementation	10
4 Revision History	2	9.1 Application Information.....	10
5 Pin Configuration and Functions	3	9.2 Typical Application.....	10
6 Specifications	4	10 Power Supply Recommendations	12
6.1 Absolute Maximum Ratings ⁽¹⁾	4	11 Layout	12
6.2 ESD Ratings.....	4	11.1 Layout Guidelines.....	12
6.3 Recommended Operating Conditions ⁽¹⁾	4	11.2 Layout Example.....	12
6.4 Thermal Information.....	5	12 Device and Documentation Support	13
6.5 Electrical Characteristics.....	5	12.1 Documentation Support.....	13
6.6 Timing Requirements.....	6	12.2 Receiving Notification of Documentation Updates.....	13
6.7 Switching Characteristics.....	6	12.3 Support Resources.....	13
6.8 Typical Characteristics.....	6	12.4 Trademarks.....	13
7 Parameter Measurement Information	7	12.5 Electrostatic Discharge Caution.....	13
8 Detailed Description	8	12.6 Glossary.....	13
8.1 Overview.....	8	13 Mechanical, Packaging, and Orderable Information	13
8.2 Functional Block Diagram.....	8		

4 Revision History

NOTE: Page numbers for previous revisions may differ from page numbers in the current version.

Changes from Revision C (March 2003) to Revision D (February 2021)	Page
• Updated the numbering format for tables, figures, and cross-references throughout the document.....	1
• Added new applications to the <i>Applications</i> section.....	1
• Removed <i>Ordering Information</i> and <i>Function</i> tables from the <i>Description</i> section.....	1
• Added the <i>Device Information</i> table to the <i>Description</i> section.....	1
• Moved package thermal impedance, Θ_{JA} for the DW, N, and NS packages to Section 6.4	4
• Added <i>ESD Ratings</i> section.....	4
• Added <i>Thermal Information</i> section.....	5
• Changed $I_{OS}(\min)$ value From: -100 mA To: -50 mA	5
• Added <i>Timing Requirements</i> , <i>Switching Characteristics</i> , and <i>Typical Characteristics</i> sections.....	6
• Added <i>Detailed Description</i> section.....	8
• Added <i>Application and Implementation</i> section.....	10
• Added <i>Power Supply Recommendations</i> and <i>Layout</i> sections.....	12

Changes from Revision B (April 1994) to Revision C (March 2003)	Page
• Added <i>Ordering Information</i> table to the <i>Description</i> section.....	1
• Added package thermal impedance, Θ_{JA} for the DW, N, and NS packages.....	4

Changes from Revision A (November 1993) to Revision B (April 1994)	Page
• First public release of production data sheet.....	1

5 Pin Configuration and Functions

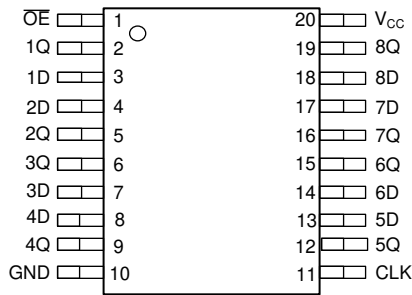

**Figure 5-1. DB, DW, N, NS, J, or W Package
20-Pin SSOP, SOIC, PDIP, SO, CDIP, or CFP
Top View**

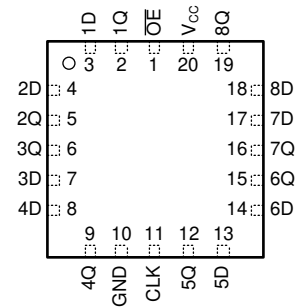

**Figure 5-2. FK Package
20-Pin LCCC
Transparent Top View**

Table 5-1. Pin Functions

PIN		I/O ⁽¹⁾	DESCRIPTION
NAME	NO.		
OE	1	I	Output enable, active low
1Q	2	O	Channel 1 output
1D	3	I	Channel 1 input
2D	4	I	Channel 2 input
2Q	5	O	Channel 2 output
3Q	6	O	Channel 3 output
3D	7	I	Channel 3 input
4D	8	I	Channel 4 input
4Q	9	O	Channel 4 output
GND	10	G	Ground
CLK	11	I	Clock, rising edge triggered
5Q	12	O	Channel 5 output
5D	13	I	Channel 5 input
6D	14	I	Channel 6 input
6Q	15	O	Channel 6 output
7Q	16	O	Channel 7 output
7D	17	I	Channel 7 input
8D	18	I	Channel 8 input
8Q	19	O	Channel 8 output
V _{CC}	20	P	Positive supply

(1) I = Input, O = Output, I/O = Input or Output, G = Ground, P = Power.

6 Specifications

6.1 Absolute Maximum Ratings ⁽¹⁾

over operating free-air temperature range (unless otherwise noted)

		MIN	MAX	UNIT
V _{CC}	Supply voltage range	-0.5	7	V
V _I	Input voltage range ⁽²⁾	-0.5	7	V
V _O	Voltage range applied to any output in the disabled or power-off state	-0.5	5.5	V
V _O	Voltage range applied to any output in the high state	-0.5	V _{CC}	V
I _{IK}	Input clamp current		-30	mA
I _{OL}	Current into any output in the low state	SN54BCT374	96	mA
		SN74BCT374	128	
T _{stg}	Storage temperature range ⁽³⁾	-65	150	°C

- Stresses beyond those listed under *absolute maximum ratings* may cause permanent damage to the device. These are stress ratings only, and functional operation of the device at these or any other conditions beyond those indicated under *recommended operating conditions* is not implied. Exposure to absolute-maximum-rated conditions for extended periods may affect device reliability.
- The negative input voltage rating may be exceeded if the input clamp current rating is observed.
- Long-term high-temperature storage and extended use at maximum recommended operating conditions or both may result in a reduction of overall device life. See http://www.ti.com/ep_quality for additional information on enhanced plastic packaging.

6.2 ESD Ratings

		VALUE	UNIT
V _(ESD)	Electrostatic discharge	Human-body model (HBM), per ANSI/ESDA/JEDEC JS-001 ¹	V
		Charged-device model (CDM), per JEDEC specification JESD22-C101 ²	

6.3 Recommended Operating Conditions ⁽¹⁾

	Operating free-air temperature (T _A)						UNIT	
	-55°C to 125°C ⁽²⁾			0°C to 70°C ⁽³⁾				
	MIN	NOM	MAX	MIN	NOM	MAX		
V _{CC}	Supply voltage	4.5	5	5.5	4.5	5	5.5	V
V _{IH}	High-level input voltage	2			2			V
V _{IL}	Low-level input voltage			0.8			0.8	V
I _{IK}	Input clamp current			-18			-18	mA
I _{OH}				-2			-15	mA
I _{OL}	Low-level output current			48			64	mA
T _A	Operating free-air temperature	-55		125	0		70	°C

- All unused inputs of the device must be held at V_{CC} or GND to ensure proper device operation. Refer to the TI application report, [Implications of Slow or Floating CMOS Inputs](#).
- Applies to SN54BCT374 devices only
- Applies to SN74BCT374 devices only

6.4 Thermal Information

THERMAL METRIC ⁽¹⁾		SN74BCT374				UNIT
		DB (SSOP)	DW (SOIC)	N (PDIP)	NS (SO)	
		20 PINS	20 PINS	20 PINS	20 PINS	
R _{θJA}	Junction-to-ambient thermal resistance	84.4	73.4	59.7	71.2	°C/W
R _{θJB}	Junction-to-board thermal resistance	40.1	41.9	40.6	36.2	°C/W
ψ _{JT}	Junction-to-top characterization parameter	6.2	14.6	24.9	7.6	°C/W
ψ _{JB}	Junction-to-board characterization parameter	39.5	41.4	40.3	35.9	°C/W
R _{θJC(top)}	Junction-to-case (top) thermal resistance	36.8	38.8	50.0	34.3	°C/W

(1) For more information about traditional and new thermal metrics, see the [Semiconductor and IC package thermal metrics](#) application report.

6.5 Electrical Characteristics

over recommended operating free-air temperature range (unless otherwise noted)

PARAMETER	TEST CONDITIONS	Operating free-air temperature (T _A)						UNIT	
		–55°C to 125°C ⁽³⁾			0°C to 70°C ⁽⁴⁾				
		MIN	TYP ⁽¹⁾	MAX	MIN	TYP ⁽¹⁾	MAX		
V _{IK}	V _{CC} = 4.5 V, I _I = –18 mA			–1.2			–1.2	V	
V _{OH}	V _{CC} = 4.5 V	I _{OH} = –3 mA		2.4	3.3	2.4	3.3	V	
		I _{OH} = –12 mA		2	3.2				
		I _{OH} = –15 mA				2	3.1		
V _{OL}	V _{CC} = 4.5 V	I _{OL} = 48 mA		0.38	0.55			V	
		I _{OL} = 64 mA				0.42	0.55		
I _I	V _{CC} = 5.5 V, V _I = 5.5 V			0.4			0.4	mA	
I _{IH}	V _{CC} = 5.5 V, V _I = 2.7 V			20			20	μA	
I _{IL}	V _{CC} = 5.5 V, V _I = 0.5 V			–0.6			–0.6	mA	
I _{OS} ⁽²⁾	V _{CC} = 5.5 V, V _O = 0 V	–50		–225		–50	–225	mA	
I _{OZH}	V _{CC} = 5.5 V, V _O = 2.7 V			50			50	μA	
I _{OZL}	V _{CC} = 5.5 V, V _O = 0.5 V			–50			–50	μA	
I _{CCL}	V _{CC} = 5.5 V			37	60		37	60	mA
I _{CCH}	V _{CC} = 5.5 V			2	5		2	5	mA
I _{CCZ}	V _{CC} = 5.5 V			5	8		5	8	mA
C _i	V _{CC} = 5 V, V _I = 2.5 V or 0.5 V			6			6	pF	
C _o	V _{CC} = 5 V, V _O = 2.5 V or 0.5 V			10			10	pF	

(1) All typical values are at V_{CC} = 5 V, T_A = 25°C.

(2) Not more than one output should be tested at a time, and the duration of the test should not exceed one second.

(3) Applies to SN54BCT374 devices only

(4) Applies to SN74BCT374 devices only

6.6 Timing Requirements

over recommended operating free-air temperature range (unless otherwise noted)

PARAMETER			Operating free-air temperature (T _A)						UNIT
			25°C ⁽¹⁾		-55°C to 125°C ⁽²⁾		0°C to 70°C ⁽³⁾		
			MIN	MAX	MIN	MAX	MIN	MAX	
f _{clock}	Clock frequency		70		70		70		MHz
t _w	Pulse duration	CLK high	7		8		7		ns
t _{su}	Setup time before CLK ↑	Data high or low	6.5		6.5		6.5		ns
t _h	Hold time after CLK ↑	Data high or low	0		0		0		ns

(1) V_{CC} = 5 V, T_A = 25°C, applies to all SN54BCT374 and SN74BCT374 devices

(2) Applies to SN54BCT374 devices only

(3) Applies to SN74BCT374 devices only

6.7 Switching Characteristics

over recommended operating free-air temperature range (unless otherwise noted)

PARAMETER	FROM (INPUT)	TO (OUTPUT)	Operating free-air temperature (T _A)						UNIT	
			25°C ⁽¹⁾			-55°C to 125°C ^{(2) (3)}		0°C to 70°C ^{(2) (4)}		
			MIN	TYP	MAX	MIN	MAX	MIN		MAX
f _{max}			70			70		70		MHz
t _{PLH}	CLK	Q	2	7.2	9.1	2	11.6	2	10.6	ns
t _{PHL}			2	7.1	8.8	2	10.6	2	10	
t _{PZH}	OE	Q	1	8.3	10.1	1	12.7	1	12.3	ns
t _{PZL}			1	8.6	10.6	1	13	1	12.7	
t _{PHZ}	OE	Q	1	4.7	6.3	1	7.1	1	6.8	ns
t _{PLZ}			1	4.8	6.3	1	7.5	1	6.8	

(1) V_{CC} = 5 V, C_L = 50 pF, R₁ = 500 Ω, R₂ = 500 Ω, T_A = 25°C, applies to all SN54BCT374 and SN74BCT374 devices

(2) V_{CC} = 4.5 V to 5.5 V, C_L = 50 pF, R₁ = 500 Ω, R₂ = 500 Ω

(3) Applies to SN54BCT374 devices only

(4) Applies to SN74BCT374 devices only

6.8 Typical Characteristics

T_A = 25°C

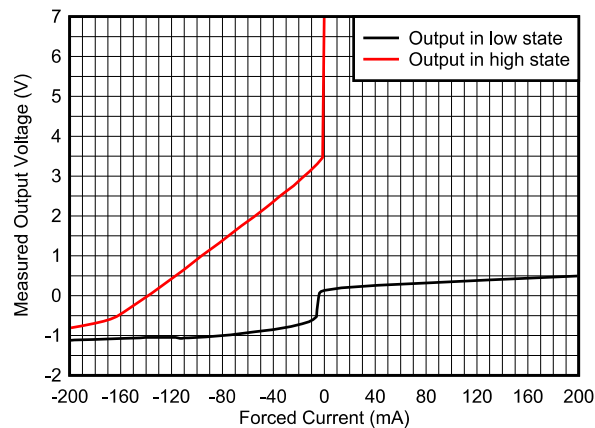
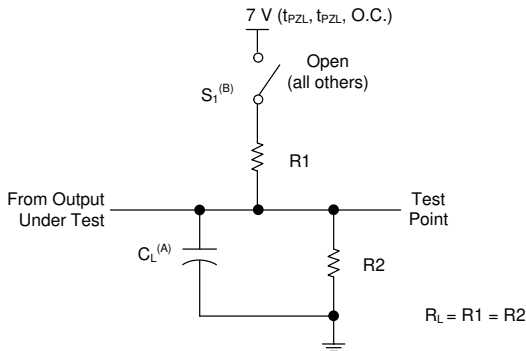

Figure 6-1. Typical output voltage versus output current for BCT family drivers

7 Parameter Measurement Information

All parameters and waveforms are not applicable to all devices.



- A. C_L includes probe and jig capacitance.
- B. When measuring propagation delay times of 3-state outputs, switch S_1 is open.

Figure 7-1. Load circuit for 3-state and open-collector outputs

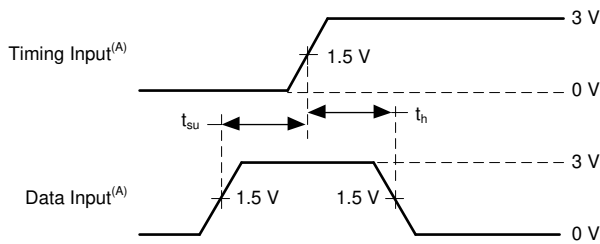

- A. All input pulses are supplied by generators having the following characteristics: $PRR \leq 10$ MHz, $t_r = t_f \leq 2.5$ ns, duty cycle = 50%.

Figure 7-3. Voltage waveforms Setup and hold times

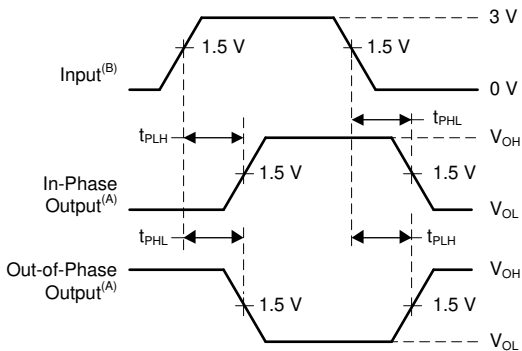

- A. The outputs are measured one at a time with one transition per measurement.
- B. All input pulses are supplied by generators having the following characteristics: $PRR \leq 10$ MHz, $t_r = t_f \leq 2.5$ ns, duty cycle = 50%.

Figure 7-5. Voltage waveforms Propagation delay times

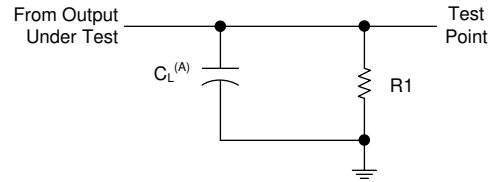

- A. C_L includes probe and jig capacitance.

Figure 7-2. Load circuit for push-pull outputs

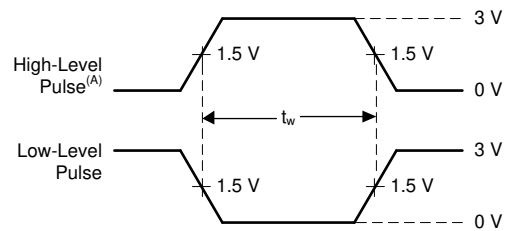

- A. All input pulses are supplied by generators having the following characteristics: $PRR \leq 10$ MHz, $t_r = t_f \leq 2.5$ ns, duty cycle = 50%.

Figure 7-4. Voltage waveforms Pulse duration

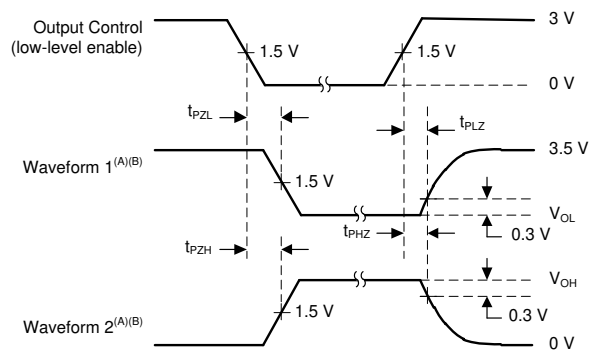

- A. The outputs are measured one at a time with one transition per measurement.
- B. Waveform 1 is for an output with internal conditions such that the output is low except when disabled by the output control. Waveform 2 is for an output with internal conditions such that the output is high except when disabled by the output control.

Figure 7-6. Voltage waveforms Enable and disable times, 3-state outputs

8 Detailed Description

8.1 Overview

These 8-bit flip-flops feature 3-state outputs designed specifically for driving highly capacitive or relatively low-impedance loads. They are particularly suitable for implementing buffer registers, I/O ports, bidirectional bus drivers, and working registers.

The eight flip-flops of the SNx4BCT374 devices are edge-triggered D-type flip-flops. On the positive transition of the clock (CLK) input, the Q outputs are set to the logic levels that were set up at the data (D) inputs.

A buffered output-enable (\overline{OE}) input can be used to place the eight outputs in either a normal logic state (high or low) or a high-impedance state. In the high-impedance state, the outputs neither load nor drive the bus lines significantly. The high-impedance state and the increased drive provide the capability to drive bus lines without need for interface or pullup components. The output-enable (\overline{OE}) input does not affect internal operations of the flip-flop. Old data can be retained or new data can be entered while the outputs are in the high-impedance state.

8.2 Functional Block Diagram

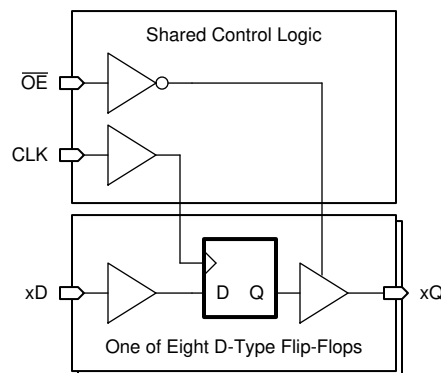

8.3 Feature Description

8.3.1 Bipolar Push-Pull Outputs

This device includes bipolar push-pull outputs. The drive capability of this device may create fast edges into light loads, so routing and load conditions should be considered to prevent ringing. Additionally, the outputs of this device are capable of driving larger currents than the device can sustain without being damaged. It is important for the output power of the device to be limited to avoid damage due to overcurrent. The electrical and thermal limits defined in the *Absolute Maximum Ratings* must be followed at all times.

Unused bipolar push-pull outputs should be left disconnected.

8.3.2 Standard CMOS Inputs

This device includes standard CMOS inputs. Standard CMOS inputs are high impedance and are typically modeled as a resistor in parallel with the input capacitance given in the *Electrical Characteristics*. The worst case resistance is calculated with the maximum input voltage, given in the *Absolute Maximum Ratings*, and the maximum input leakage current, given in the *Electrical Characteristics*, using Ohm's law ($R = V \div I$).

Standard CMOS inputs require that input signals transition between valid logic states quickly, as defined by the input transition time or rate in the *Recommended Operating Conditions* table. Failing to meet this specification will result in excessive power consumption and could cause oscillations. More details can be found in [Implications of Slow or Floating CMOS Inputs](#).

Do not leave standard CMOS inputs floating at any time during operation. Unused inputs must be terminated at V_{CC} or GND. If a system will not be actively driving an input at all times, a pull-up or pull-down resistor can be added to provide a valid input voltage during these times. The resistor value will depend on multiple factors, however a 10-k Ω resistor is recommended and will typically meet all requirements.

8.3.3 Clamp Diode Structure

The inputs and outputs to this device have negative clamping diodes only as depicted in [Figure 8-1](#).

CAUTION

Voltages beyond the values specified in the *Absolute Maximum Ratings* table can cause damage to the device. The input and output voltage ratings may be exceeded if the input and output clamp-current ratings are observed.

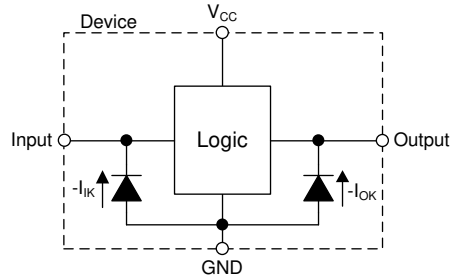

Figure 8-1. Electrical Placement of Clamping Diodes for Each Input and Output

8.4 Device Functional Modes

The *Function Table* below lists the functional modes of the SNx4BCT374.

Table 8-1. Function Table

INPUTS ⁽¹⁾			OUTPUT ⁽²⁾
OE	CLK	D	Q
L	↑	H	H
L	↑	L	L
L	H or L	X	Q ₀
H	X	X	Z

- (1) L = Low input, H = High input, ↑ = Low to high transition, X = Do not care.
 (2) L = Low output, H = High output, Q₀ = Previous state, Z = High impedance.

9 Application and Implementation

Note

Information in the following applications sections is not part of the TI component specification, and TI does not warrant its accuracy or completeness. TI's customers are responsible for determining suitability of components for their purposes, as well as validating and testing their design implementation to confirm system functionality.

9.1 Application Information

The SNx4BCT374 contains multiple D-type flip-flops that are operated by the same clock. By connecting multiple channels together in series, a shift register can be formed. This produces a delay of a specific number of clock cycles for incoming data. The application schematic shown below gives an example of using three channels of the SNx4BCT374 to produce a delay of three clock cycles.

9.2 Typical Application

9.2.1 Application

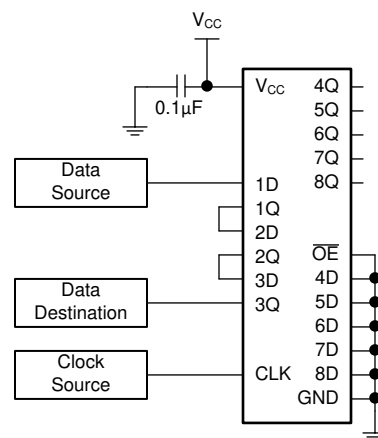

Figure 9-1. Typical application block diagram

9.2.2 Design Requirements

9.2.2.1 Power Considerations

Ensure the desired supply voltage is within the range specified in the *Recommended Operating Conditions*. The supply voltage sets the device's electrical characteristics as described in the *Electrical Characteristics*.

The positive voltage supply must be capable of sourcing current equal to the total current to be sourced by all outputs of the SNx4BCT374 plus the maximum static supply current, I_{CC} , listed in *Electrical Characteristics* and any transient current required for switching. The logic device can only source as much current as is provided by the positive supply source.

The ground must be capable of sinking current equal to the total current to be sunk by all outputs of the SNx4BCT374 plus the maximum supply current, I_{CC} , listed in *Electrical Characteristics*, and any transient current required for switching. The logic device can only sink as much current as can be sunk into its ground connection.

The SNx4BCT374 can drive a load with a total capacitance less than or equal to 50 pF while still meeting all of the datasheet specifications. Larger capacitive loads can be applied, however it is not recommended to exceed 50 pF.

The SNx4BCT374 can drive a load with total resistance described by $R_L \geq V_O / I_O$, with the output voltage and current defined in the *Electrical Characteristics* table with V_{OH} and V_{OL} . When outputting in the high state, the output voltage in the equation is defined as the difference between the measured output voltage and the supply voltage at the V_{CC} pin.

Thermal increase can be calculated using the information provided in [Thermal Characteristics of Standard Linear and Logic \(SLL\) Packages and Devices](#).

9.2.2.2 Output Considerations

The positive supply voltage is used to produce the output high voltage. Drawing current from the output will decrease the output voltage as specified by the V_{OH} specification in the *Electrical Characteristics*. The ground voltage is used to produce the output low voltage. Sinking current into the output will increase the output voltage as specified by the V_{OL} specification in the *Electrical Characteristics*.

Push-pull bipolar outputs should never be connected directly together. This can cause excessive current and damage to the device.

Unused outputs can be left floating. Do not connect outputs directly to V_{CC} or ground.

Refer to *Feature Description* section for additional information regarding the outputs for this device.

9.2.2.3 Input Considerations

Input signals must cross $V_{IL(max)}$ to be considered a logic low, and $V_{IH(min)}$ to be considered a logic high. Do not exceed the maximum input voltage range found in the *Absolute Maximum Ratings*.

Unused inputs must be terminated to either V_{CC} or ground. These can be directly connected if the input is completely unused, or they can be connected with a pull-up or pull-down resistor if the input is to be used sometimes, but not always. A pull-up resistor is used for a default state of high, and a pull-down resistor is used for a default state of low. The resistor size is limited by drive current of the controller, leakage current into the SNx4BCT374, as specified in the *Electrical Characteristics*, and the desired input transition rate. A 10-k Ω resistor value is often used due to these factors.

The SNx4BCT374 has CMOS inputs and thus requires fast input transitions to operate correctly. Slow input transitions can cause oscillations, additional power consumption, and reduction in device reliability.

Refer to the *Feature Description* section for additional information regarding the inputs for this device.

9.2.3 Detailed Design Procedure

1. Add a decoupling capacitor from V_{CC} to GND. The capacitor needs to be placed physically close to the SNx4BCT374 and electrically close to both the V_{CC} and GND pins. An example layout is shown in the *Layout* section.
2. Ensure the capacitive load at the output is ≤ 50 pF. This is not a hard limit, however it will ensure optimal performance. This can be accomplished by providing short, appropriately sized traces from the SNx4BCT374 to the receiving device(s).
3. Ensure the resistive load at the output is larger than $(V_{CC} / I_{O(max)}) \Omega$. This will ensure that the maximum output current from the *Absolute Maximum Ratings* is not violated. Most CMOS inputs have a resistive load measured in megaohms; much larger than the minimum calculated above.
4. Thermal issues are rarely a concern for logic gates, however the power consumption and thermal increase can be calculated using the steps provided in the application report, [CMOS Power Consumption and Cpd Calculation](#).
5. This device includes D-type flip-flop circuits. The output of these circuits is unknown at system startup. Data must be clocked into each D-type flip-flop to initialize it into a known state.

9.2.4 Application Curves

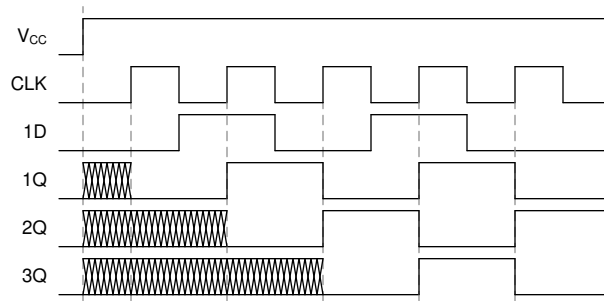

Figure 9-2. Application timing diagram

10 Power Supply Recommendations

The power supply can be any voltage between the minimum and maximum supply voltage rating located in the *Recommended Operating Conditions*. Each V_{CC} terminal should have a good bypass capacitor to prevent power disturbance. A 0.1- μF capacitor is recommended for this device. It is acceptable to parallel multiple bypass caps to reject different frequencies of noise. The 0.1- μF and 1- μF capacitors are commonly used in parallel. The bypass capacitor should be installed as close to the power terminal as possible for best results, as shown in given example layout image.

11 Layout

11.1 Layout Guidelines

When using multiple-input and multiple-channel logic devices inputs must not ever be left floating. In many cases, functions or parts of functions of digital logic devices are unused; for example, when only two inputs of a triple-input AND gate are used or only 3 of the 4 buffer gates are used. Such unused input pins must not be left unconnected because the undefined voltages at the outside connections result in undefined operational states. All unused inputs of digital logic devices must be connected to a logic high or logic low voltage, as defined by the input voltage specifications, to prevent them from floating. The logic level that must be applied to any particular unused input depends on the function of the device. Generally, the inputs are tied to GND or V_{CC} , whichever makes more sense for the logic function or is more convenient.

11.2 Layout Example

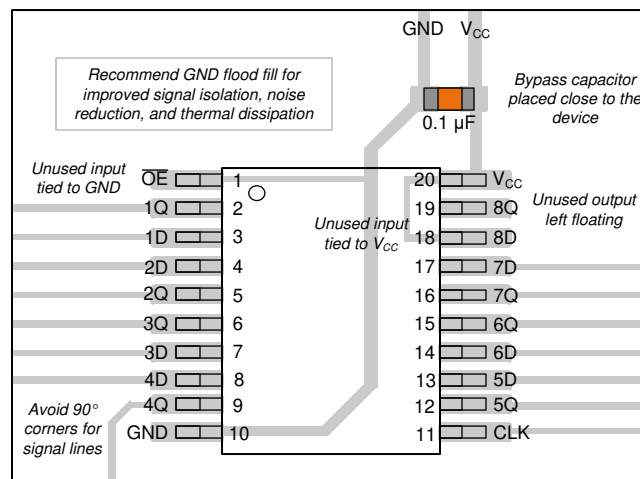

Figure 11-1. Example layout for the SN74BCT374.

12 Device and Documentation Support

TI offers an extensive line of development tools. Tools and software to evaluate the performance of the device, generate code, and develop solutions are listed below.

12.1 Documentation Support

12.1.1 Related Documentation

For related documentation see the following:

- Texas Instruments, [Designing With Logic application report](#)
- Texas Instruments, [Input and Output Characteristics of Digital Integrated Circuits application report](#)
- Texas Instruments, [Implications of Slow or Floating CMOS Inputs application report](#)
- Texas Instruments, [Understanding and Interpreting Standard-Logic Data Sheets application report](#)

12.2 Receiving Notification of Documentation Updates

To receive notification of documentation updates, navigate to the device product folder on [ti.com](#). Click on *Subscribe to updates* to register and receive a weekly digest of any product information that has changed. For change details, review the revision history included in any revised document.

12.3 Support Resources

TI E2E™ [support forums](#) are an engineer's go-to source for fast, verified answers and design help — straight from the experts. Search existing answers or ask your own question to get the quick design help you need.

Linked content is provided "AS IS" by the respective contributors. They do not constitute TI specifications and do not necessarily reflect TI's views; see TI's [Terms of Use](#).

12.4 Trademarks

TI E2E™ is a trademark of Texas Instruments.
All trademarks are the property of their respective owners.

12.5 Electrostatic Discharge Caution



This integrated circuit can be damaged by ESD. Texas Instruments recommends that all integrated circuits be handled with appropriate precautions. Failure to observe proper handling and installation procedures can cause damage.

ESD damage can range from subtle performance degradation to complete device failure. Precision integrated circuits may be more susceptible to damage because very small parametric changes could cause the device not to meet its published specifications.

12.6 Glossary

[TI Glossary](#) This glossary lists and explains terms, acronyms, and definitions.

13 Mechanical, Packaging, and Orderable Information

The following pages include mechanical, packaging, and orderable information. This information is the most current data available for the designated devices. This data is subject to change without notice and revision of this document. For browser-based versions of this data sheet, refer to the left-hand navigation.

PACKAGING INFORMATION

Orderable Device	Status (1)	Package Type	Package Drawing	Pins	Package Qty	Eco Plan (2)	Lead finish/ Ball material (6)	MSL Peak Temp (3)	Op Temp (°C)	Device Marking (4/5)	Samples
5962-9051601M2A	ACTIVE	LCCC	FK	20	55	Non-RoHS & Green	SNPB	N / A for Pkg Type	-55 to 125	5962-9051601M2A SNJ54BCT374FK	Samples
5962-9051601MRA	ACTIVE	CDIP	J	20	20	Non-RoHS & Green	SNPB	N / A for Pkg Type	-55 to 125	5962-9051601MR A SNJ54BCT374J	Samples
5962-9051601MSA	ACTIVE	CFP	W	20	25	Non-RoHS & Green	SNPB	N / A for Pkg Type	-55 to 125	5962-9051601MS A SNJ54BCT374W	Samples
SN74BCT374DW	ACTIVE	SOIC	DW	20	25	RoHS & Green	NIPDAU	Level-1-260C-UNLIM	0 to 70	BCT374	Samples
SN74BCT374N	ACTIVE	PDIP	N	20	20	RoHS & Non-Green	NIPDAU	N / A for Pkg Type	0 to 70	SN74BCT374N	Samples
SN74BCT374NSR	ACTIVE	SO	NS	20	2000	RoHS & Green	NIPDAU	Level-1-260C-UNLIM	0 to 70	BCT374	Samples
SNJ54BCT374FK	ACTIVE	LCCC	FK	20	55	Non-RoHS & Green	SNPB	N / A for Pkg Type	-55 to 125	5962-9051601M2A SNJ54BCT374FK	Samples
SNJ54BCT374J	ACTIVE	CDIP	J	20	20	Non-RoHS & Green	SNPB	N / A for Pkg Type	-55 to 125	5962-9051601MR A SNJ54BCT374J	Samples
SNJ54BCT374W	ACTIVE	CFP	W	20	25	Non-RoHS & Green	SNPB	N / A for Pkg Type	-55 to 125	5962-9051601MS A SNJ54BCT374W	Samples

(1) The marketing status values are defined as follows:

ACTIVE: Product device recommended for new designs.

LIFEBUY: TI has announced that the device will be discontinued, and a lifetime-buy period is in effect.

NRND: Not recommended for new designs. Device is in production to support existing customers, but TI does not recommend using this part in a new design.

PREVIEW: Device has been announced but is not in production. Samples may or may not be available.

OBSOLETE: TI has discontinued the production of the device.

(2) **RoHS:** TI defines "RoHS" to mean semiconductor products that are compliant with the current EU RoHS requirements for all 10 RoHS substances, including the requirement that RoHS substance do not exceed 0.1% by weight in homogeneous materials. Where designed to be soldered at high temperatures, "RoHS" products are suitable for use in specified lead-free processes. TI may reference these types of products as "Pb-Free".

RoHS Exempt: TI defines "RoHS Exempt" to mean products that contain lead but are compliant with EU RoHS pursuant to a specific EU RoHS exemption.

Green: TI defines "Green" to mean the content of Chlorine (Cl) and Bromine (Br) based flame retardants meet JS709B low halogen requirements of ≤ 1000 ppm threshold. Antimony trioxide based flame retardants must also meet the ≤ 1000 ppm threshold requirement.

(3) MSL, Peak Temp. - The Moisture Sensitivity Level rating according to the JEDEC industry standard classifications, and peak solder temperature.

(4) There may be additional marking, which relates to the logo, the lot trace code information, or the environmental category on the device.

(5) Multiple Device Markings will be inside parentheses. Only one Device Marking contained in parentheses and separated by a "~" will appear on a device. If a line is indented then it is a continuation of the previous line and the two combined represent the entire Device Marking for that device.

(6) Lead finish/Ball material - Orderable Devices may have multiple material finish options. Finish options are separated by a vertical ruled line. Lead finish/Ball material values may wrap to two lines if the finish value exceeds the maximum column width.

Important Information and Disclaimer: The information provided on this page represents TI's knowledge and belief as of the date that it is provided. TI bases its knowledge and belief on information provided by third parties, and makes no representation or warranty as to the accuracy of such information. Efforts are underway to better integrate information from third parties. TI has taken and continues to take reasonable steps to provide representative and accurate information but may not have conducted destructive testing or chemical analysis on incoming materials and chemicals. TI and TI suppliers consider certain information to be proprietary, and thus CAS numbers and other limited information may not be available for release.

In no event shall TI's liability arising out of such information exceed the total purchase price of the TI part(s) at issue in this document sold by TI to Customer on an annual basis.

OTHER QUALIFIED VERSIONS OF SN54BCT374, SN74BCT374 :

● Catalog : [SN74BCT374](#)

● Military : [SN54BCT374](#)

NOTE: Qualified Version Definitions:

● Catalog - TI's standard catalog product

● Military - QML certified for Military and Defense Applications

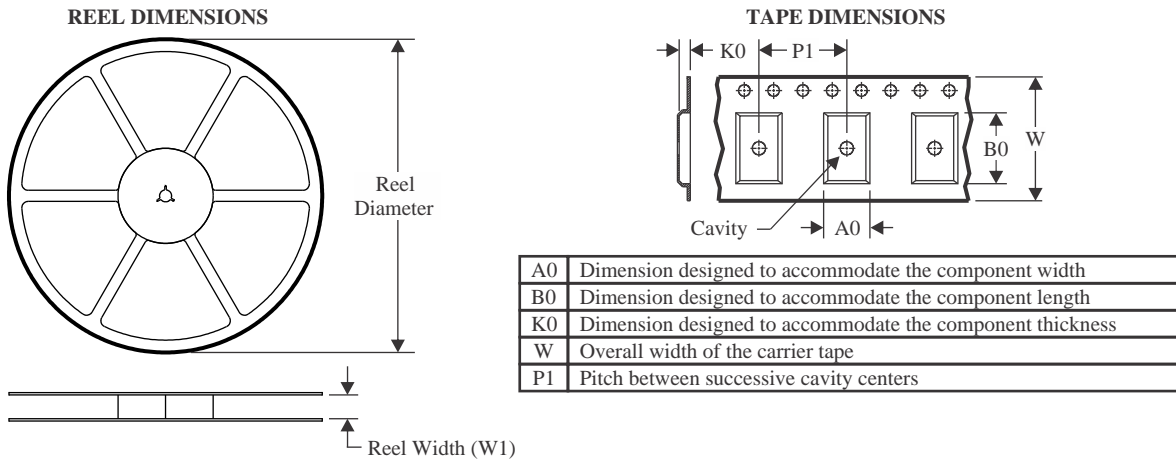
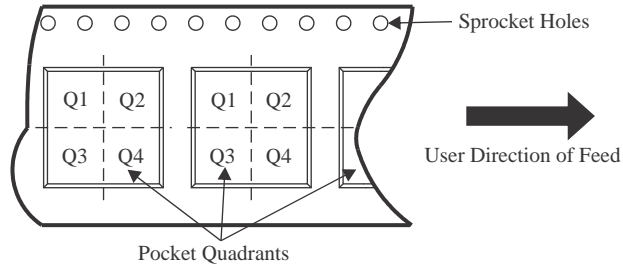
TAPE AND REEL INFORMATION

QUADRANT ASSIGNMENTS FOR PIN 1 ORIENTATION IN TAPE

*All dimensions are nominal

Device	Package Type	Package Drawing	Pins	SPQ	Reel Diameter (mm)	Reel Width W1 (mm)	A0 (mm)	B0 (mm)	K0 (mm)	P1 (mm)	W (mm)	Pin1 Quadrant
SN74BCT374NSR	SO	NS	20	2000	330.0	24.4	8.4	13.0	2.5	12.0	24.0	Q1

TAPE AND REEL BOX DIMENSIONS

*All dimensions are nominal

Device	Package Type	Package Drawing	Pins	SPQ	Length (mm)	Width (mm)	Height (mm)
SN74BCT374NSR	SO	NS	20	2000	367.0	367.0	45.0

TUBE

*All dimensions are nominal

Device	Package Name	Package Type	Pins	SPQ	L (mm)	W (mm)	T (μm)	B (mm)
5962-9051601M2A	FK	LCCC	20	55	506.98	12.06	2030	NA
5962-9051601MSA	W	CFP	20	25	506.98	26.16	6220	NA
SN74BCT374DW	DW	SOIC	20	25	507	12.83	5080	6.6
SN74BCT374N	N	PDIP	20	20	506	13.97	11230	4.32
SNJ54BCT374FK	FK	LCCC	20	55	506.98	12.06	2030	NA
SNJ54BCT374W	W	CFP	20	25	506.98	26.16	6220	NA

W (R-GDFP-F20)

CERAMIC DUAL FLATPACK



- NOTES:
- A. All linear dimensions are in inches (millimeters).
 - B. This drawing is subject to change without notice.
 - C. This package can be hermetically sealed with a ceramic lid using glass frit.
 - D. Index point is provided on cap for terminal identification only.
 - E. Falls within Mil-Std 1835 GDFP2-F20

MECHANICAL DATA

NS (R-PDSO-G**)

PLASTIC SMALL-OUTLINE PACKAGE

14-PINS SHOWN



- NOTES:
- A. All linear dimensions are in millimeters.
 - B. This drawing is subject to change without notice.
 - C. Body dimensions do not include mold flash or protrusion, not to exceed 0,15.

J (R-GDIP-T**)

14 LEADS SHOWN

CERAMIC DUAL IN-LINE PACKAGE



DIM \ PINS **	14	16	18	20
A	0.300 (7,62) BSC	0.300 (7,62) BSC	0.300 (7,62) BSC	0.300 (7,62) BSC
B MAX	0.785 (19,94)	.840 (21,34)	0.960 (24,38)	1.060 (26,92)
B MIN	—	—	—	—
C MAX	0.300 (7,62)	0.300 (7,62)	0.310 (7,87)	0.300 (7,62)
C MIN	0.245 (6,22)	0.245 (6,22)	0.220 (5,59)	0.245 (6,22)



4040083/F 03/03

- NOTES:
- All linear dimensions are in inches (millimeters).
 - This drawing is subject to change without notice.
 - This package is hermetically sealed with a ceramic lid using glass frit.
 - Index point is provided on cap for terminal identification only on press ceramic glass frit seal only.
 - Falls within MIL STD 1835 GDIP1-T14, GDIP1-T16, GDIP1-T18 and GDIP1-T20.

GENERIC PACKAGE VIEW

FK 20

LCCC - 2.03 mm max height

8.89 x 8.89, 1.27 mm pitch

LEADLESS CERAMIC CHIP CARRIER

This image is a representation of the package family, actual package may vary.
Refer to the product data sheet for package details.



4229370VA\

N (R-PDIP-T**)

PLASTIC DUAL-IN-LINE PACKAGE

16 PINS SHOWN



- NOTES:
- A. All linear dimensions are in inches (millimeters).
 - B. This drawing is subject to change without notice.
 - Falls within JEDEC MS-001, except 18 and 20 pin minimum body length (Dim A).
 - The 20 pin end lead shoulder width is a vendor option, either half or full width.

EXAMPLE BOARD LAYOUT

DW0020A

SOIC - 2.65 mm max height

SOIC



LAND PATTERN EXAMPLE
SCALE:6X



SOLDER MASK DETAILS

4220724/A 05/2016

NOTES: (continued)

- 6. Publication IPC-7351 may have alternate designs.
- 7. Solder mask tolerances between and around signal pads can vary based on board fabrication site.

EXAMPLE STENCIL DESIGN

DW0020A

SOIC - 2.65 mm max height

SOIC



SOLDER PASTE EXAMPLE
BASED ON 0.125 mm THICK STENCIL
SCALE:6X

4220724/A 05/2016

NOTES: (continued)

8. Laser cutting apertures with trapezoidal walls and rounded corners may offer better paste release. IPC-7525 may have alternate design recommendations.
9. Board assembly site may have different recommendations for stencil design.

IMPORTANT NOTICE AND DISCLAIMER

TI PROVIDES TECHNICAL AND RELIABILITY DATA (INCLUDING DATA SHEETS), DESIGN RESOURCES (INCLUDING REFERENCE DESIGNS), APPLICATION OR OTHER DESIGN ADVICE, WEB TOOLS, SAFETY INFORMATION, AND OTHER RESOURCES "AS IS" AND WITH ALL FAULTS, AND DISCLAIMS ALL WARRANTIES, EXPRESS AND IMPLIED, INCLUDING WITHOUT LIMITATION ANY IMPLIED WARRANTIES OF MERCHANTABILITY, FITNESS FOR A PARTICULAR PURPOSE OR NON-INFRINGEMENT OF THIRD PARTY INTELLECTUAL PROPERTY RIGHTS.

These resources are intended for skilled developers designing with TI products. You are solely responsible for (1) selecting the appropriate TI products for your application, (2) designing, validating and testing your application, and (3) ensuring your application meets applicable standards, and any other safety, security, regulatory or other requirements.

These resources are subject to change without notice. TI grants you permission to use these resources only for development of an application that uses the TI products described in the resource. Other reproduction and display of these resources is prohibited. No license is granted to any other TI intellectual property right or to any third party intellectual property right. TI disclaims responsibility for, and you will fully indemnify TI and its representatives against, any claims, damages, costs, losses, and liabilities arising out of your use of these resources.

TI's products are provided subject to [TI's Terms of Sale](#) or other applicable terms available either on [ti.com](https://www.ti.com) or provided in conjunction with such TI products. TI's provision of these resources does not expand or otherwise alter TI's applicable warranties or warranty disclaimers for TI products.

TI objects to and rejects any additional or different terms you may have proposed.

Mailing Address: Texas Instruments, Post Office Box 655303, Dallas, Texas 75265
Copyright © 2023, Texas Instruments Incorporated

Looking for pricing, stock, or lifecycle information?

Click below to explore more details on WIN SOURCE:

- ⊖ [View SN74BCT374NSR on WIN SOURCE](#)
- ⊖ [Texas Instruments](#) Information

Optimize Your Supply Chain with WIN SOURCE Solutions

- ✓ Global Sourcing Solution
- ✓ Obsolete Management
- ✓ Cost Control Management
- ✓ Shortage Management
- ✓ Alternative Solution
- ✓ Excess Inventory Management