



THE DATASHEET OF BUL3P5





BUL3P5

MEDIUM VOLTAGE FAST-SWITCHING PNP POWER TRANSISTOR

Features

- MEDIUM VOLTAGE CAPABILITY
- LOW SPREAD OF DYNAMIC PARAMETERS
- MINIMUM LOT-TO-LOT SPREAD FOR RELIABLE OPERATION
- VERY HIGH SWITCHING SPEED

Applications

- ELECTRONIC BALLASTS FOR FLUORESCENT LIGHTING

Description

The BUL3P5 is manufactured using high voltage Multi-Epitaxial Planar technology for high switching speeds and medium voltage capability.

It uses a Cellular Emitter structure with planar edge termination to enhance switching speeds while maintaining the wide RBSOA.

The device is expressly designed for a new solution to be used in compact fluorescent lamps, H.F. ballast voltage FED where it is coupled with the BUL3N7, its complementary NPN transistor.

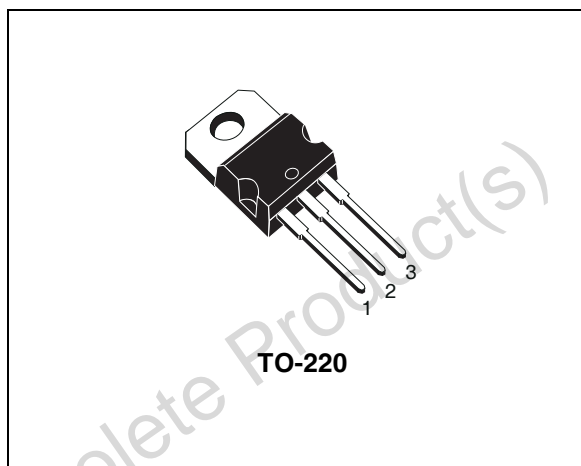

Internal Schematic Diagram

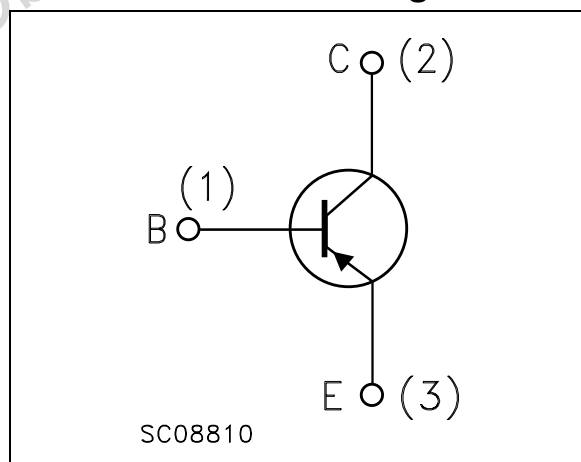

Order Codes

Part Number	Marking	Package	Packing
BUL3P5	BUL3P5	TO-220	TUBE

1 Absolute Maximum Ratings

Table 1. Absolute Maximum Rating

Symbol	Parameter	Value	Unit
V_{CES}	Collector-Emitter Voltage ($V_{BE} = 0$)	-500	V
V_{CEO}	Collector-Emitter Voltage ($I_B = 0$)	-400	V
V_{EBO}	Emitter-Base Voltage ($I_C = 0$, $I_B = -0.75$ A, $t_p < 100$ ms, $T_j < 150^\circ\text{C}$)	$V_{(BR)EBO}$	V
I_C	Collector Current	-3	A
I_{CM}	Collector Peak Current ($t_p < 5$ ms)	-6	A
I_B	Base Current	-1.5	A
I_{BM}	Base Peak Current ($t_p < 5$ ms)	-3	A
P_{TOT}	Total dissipation at $T_c = 25^\circ\text{C}$	60	W
T_{stg}	Storage Temperature	-65 to 150	$^\circ\text{C}$
T_J	Max. Operating Junction Temperature	150	$^\circ\text{C}$

Table 2. Thermal Data

Symbol	Parameter	Value	Unit
$R_{thJ-case}$	Thermal Resistance Junction-Case Max	2.08	$^\circ\text{C/W}$
$R_{thJ-amb}$	Thermal Resistance Junction-Ambient Max	62.5	$^\circ\text{C/W}$

2 Electrical Characteristics

Table 3. Electrical Characteristics ($T_{CASE} = 25^{\circ}C$; unless otherwise specified)

Symbol	Parameter	Test Conditions	Min.	Typ.	Max.	Unit
I_{CES}	Collector Cut-off Current ($V_{BE} = 0$)	$V_{CE} = -500 V$			-0.1	mA
		$V_{CE} = -500 V$ $T_C = 125^{\circ}C$			-0.5	mA
$V_{(BR)EBO}$	Emitter-Base Breakdown Voltage ($I_C = 0$)	$I_E = -10 mA$	-5		-10	V
$V_{CEO(sus)}$ <i>Note: 1</i>	Collector-Emitter Sustaining Voltage ($I_B = 0$)	$I_C = 100 mA$	-400			V
$V_{CE(sat)}$ <i>Note: 1</i>	Collector-Emitter Saturation Voltage	$I_C = -0.7 A$ $I_B = -0.1 A$			-0.5	V
		$I_C = -1 A$ $I_B = -0.2 A$			-0.5	V
$V_{BE(sat)}$ <i>Note: 1</i>	Base-Emitter Saturation Voltage	$I_C = -0.5 A$ $I_B = -0.1 A$			-1.1	V
		$I_C = -1 A$ $I_B = -0.2 A$			-1.2	V
		$I_C = -2 A$ $I_B = -0.4 A$			-1.3	V
h_{FE}	DC Current Gain	$I_C = -10 mA$ $V_{CE} = -5 V$	10			
		$I_C = -0.7 A$ $V_{CE} = -5 V$	18		34	
		$I_C = -2 A$ $V_{CE} = -5 V$	4			
t_r t_s t_f	RESISTIVE LOAD	$I_C = -0.7 A$ $V_{CC} = -250 V$ $I_{B1} = -0.14 A$ $I_{B2} = 0.14 A$ $T_p = 30 \mu s$				
	Rise Time			100	ns	
	Storage Time			2.4	μs	
	Fall Time		80	ns		
t_s t_f	INDUCTIVE LOAD	$I_C = -1 A$ $I_{B1} = -0.2 A$ $V_{BE(off)} = 5 V$ $R_{bb} = 0 \Omega$ $L = 1 mH$ $V_{clamp} = 200 V$				
	Storage Time			450	ns	
	Fall Time		70	ns		

Note: 1 Pulsed duration = 300 μs , duty cycle $\leq 1.5\%$.

2.1 Typical Characteristics

Figure 1. Safe Operating Area

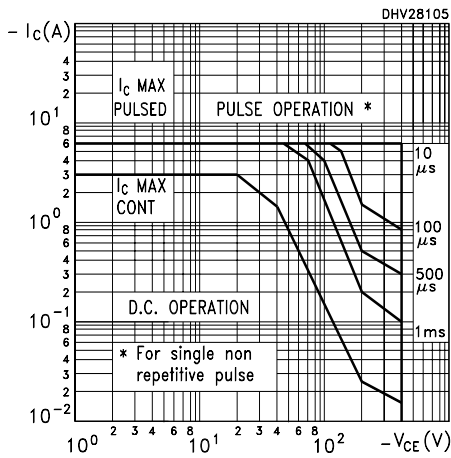

Figure 3. DC Current Gain

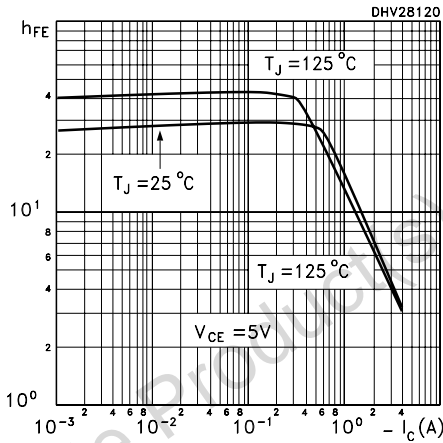

Figure 5. Base Emitter Saturation Voltage

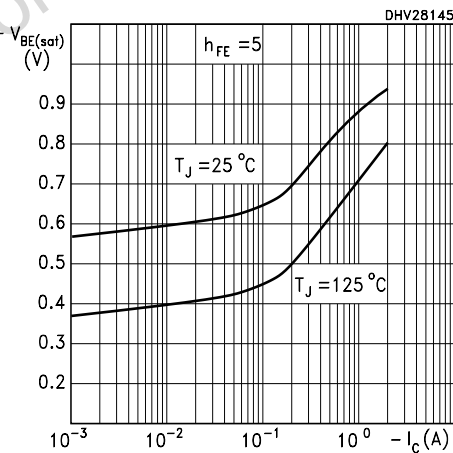

Figure 2. DC Current Gain

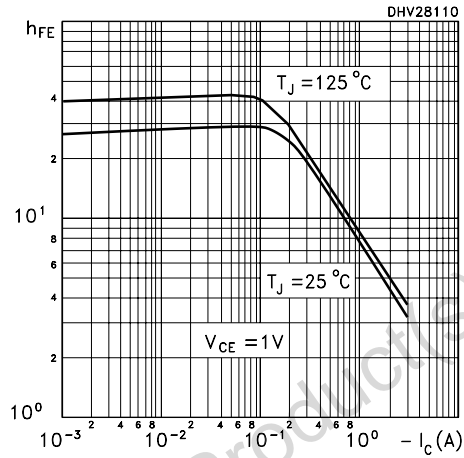

Figure 4. Collector Emitter Saturation Voltage

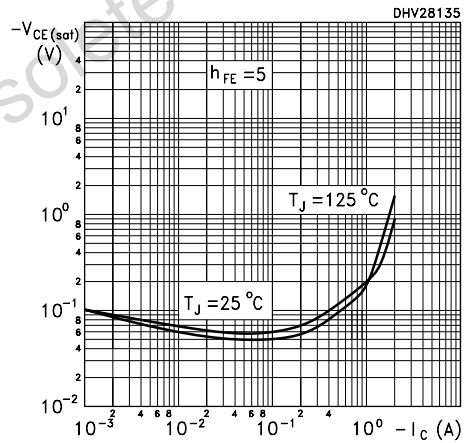

Figure 6. Switching Times Resistive Load

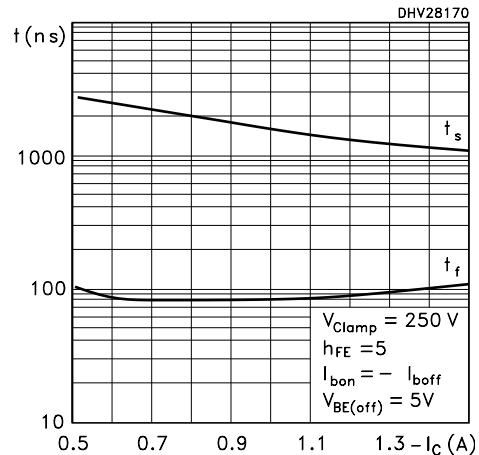

Figure 7. Switching Times Inductive Load

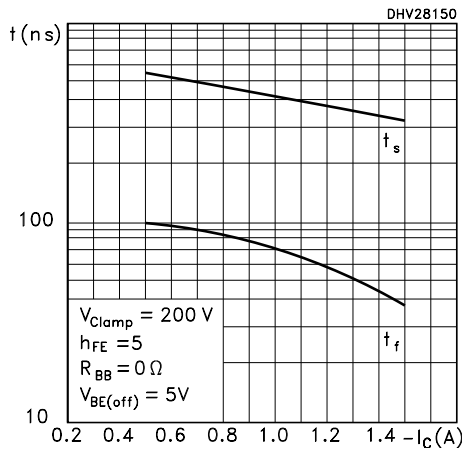
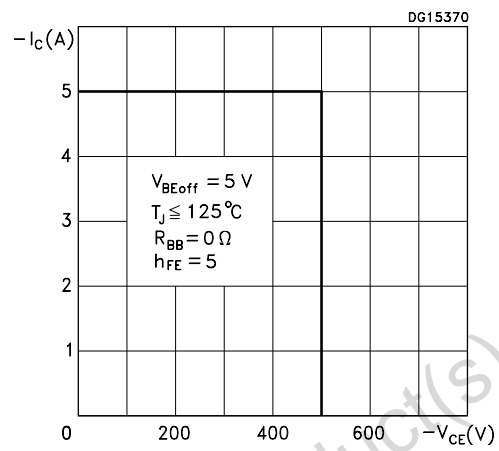

Figure 8. Reverse Biased SOA



Obsolete Product(s) - Obsolete Product(s)

3 Test Circuits

Figure 9. Inductive Load Switching Test Circuit

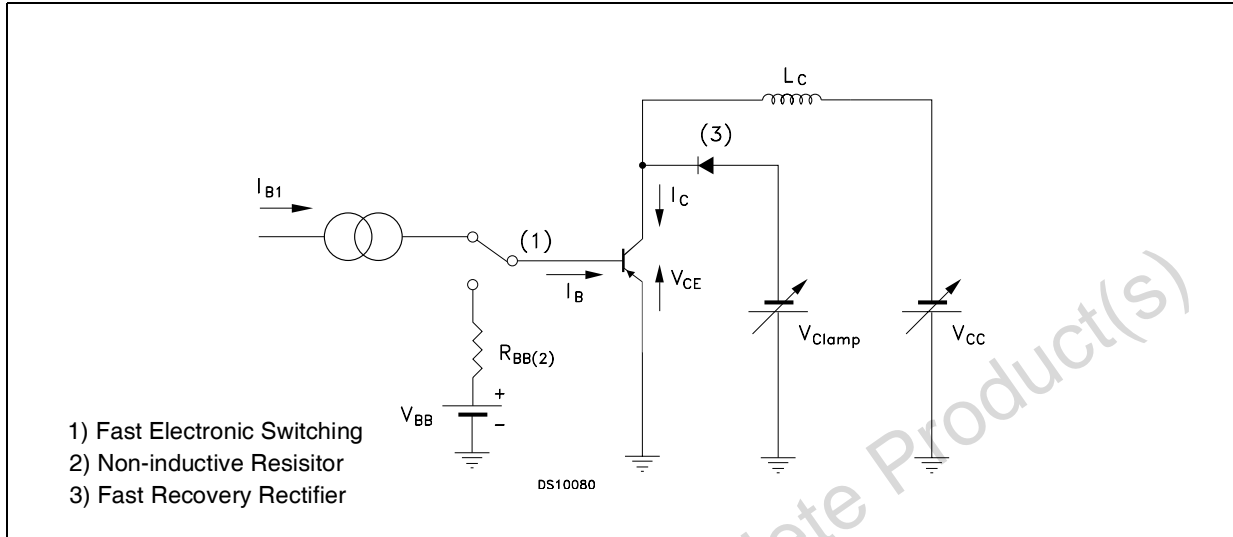
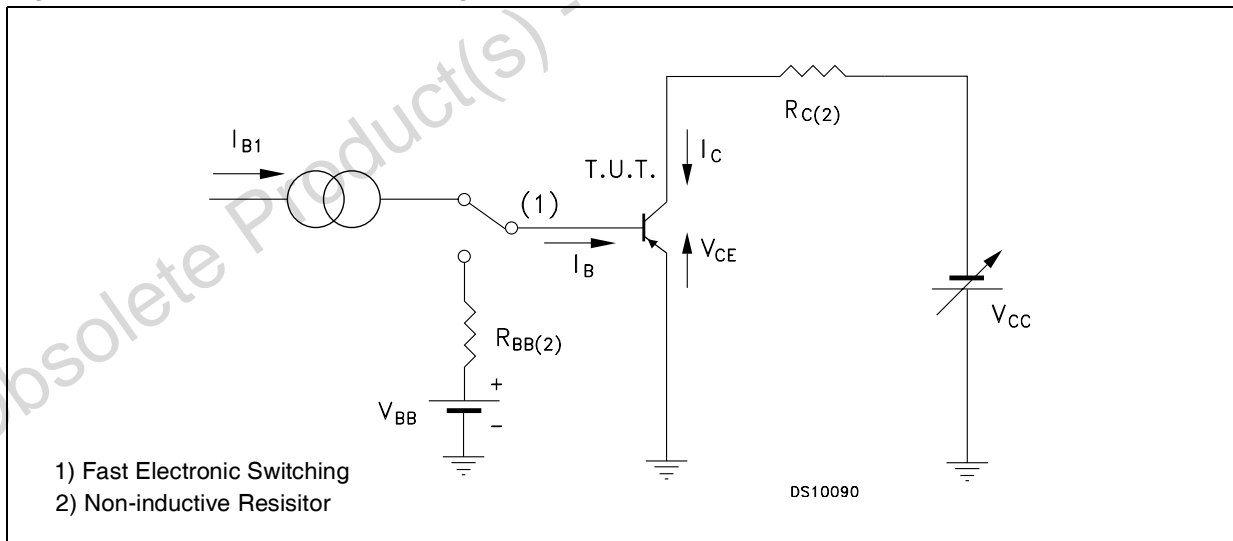

Figure 10. Resistive Load Switching Test Circuits



4 Package Mechanical Data

In order to meet environmental requirements, ST offers these devices in ECOPACK® packages. These packages have a Lead-free second level interconnect . The category of second level interconnect is marked on the package and on the inner box label, in compliance with JEDEC Standard JESD97. The maximum ratings related to soldering conditions are also marked on the inner box label. ECOPACK is an ST trademark. ECOPACK specifications are available at: www.st.com

Obsolete Product(s) - Obsolete Product(s)

TO-220 MECHANICAL DATA

DIM.	mm.			inch		
	MIN.	TYP.	MAX.	MIN.	TYP.	MAX.
A	4.40		4.60	0.173		0.181
b	0.61		0.88	0.024		0.034
b1	1.15		1.70	0.045		0.066
c	0.49		0.70	0.019		0.027
D	15.25		15.75	0.60		0.620
E	10		10.40	0.393		0.409
e	2.40		2.70	0.094		0.106
e1	4.95		5.15	0.194		0.202
F	1.23		1.32	0.048		0.052
H1	6.20		6.60	0.244		0.256
J1	2.40		2.72	0.094		0.107
L	13		14	0.511		0.551
L1	3.50		3.93	0.137		0.154
L20		16.40			0.645	
L30		28.90			1.137	
øP	3.75		3.85	0.147		0.151
Q	2.65		2.95	0.104		0.116

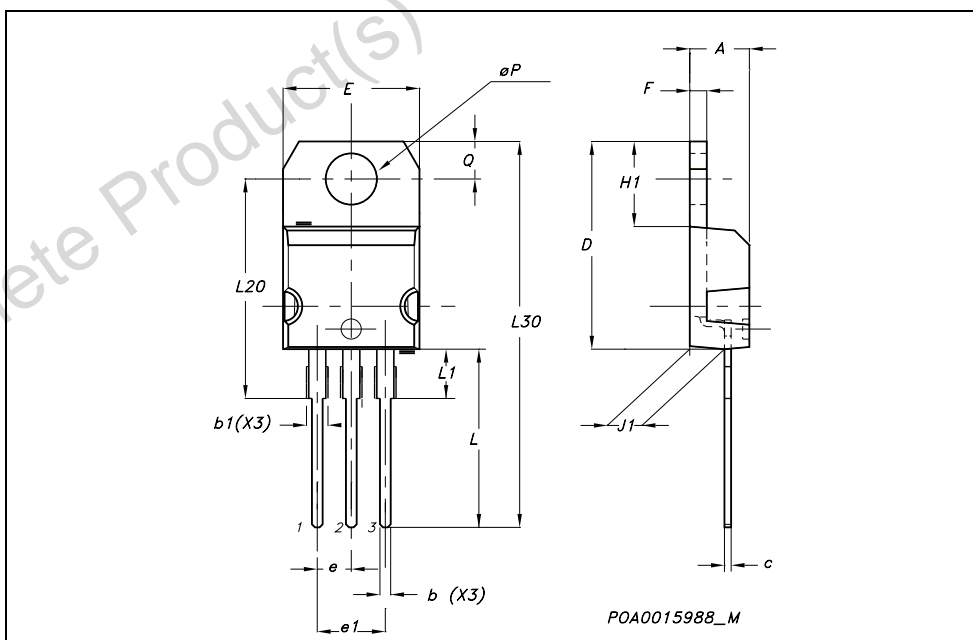

5 Revision History

Date	Revision	Changes
09-Dec-2005	2	Inserted curves

Obsolete Product(s) - Obsolete Product(s)

Information furnished is believed to be accurate and reliable. However, STMicroelectronics assumes no responsibility for the consequences of use of such information nor for any infringement of patents or other rights of third parties which may result from its use. No license is granted by implication or otherwise under any patent or patent rights of STMicroelectronics. Specifications mentioned in this publication are subject to change without notice. This publication supersedes and replaces all information previously supplied. STMicroelectronics products are not authorized for use as critical components in life support devices or systems without express written approval of STMicroelectronics.

The ST logo is a registered trademark of STMicroelectronics.
All other names are the property of their respective owners

© 2005 STMicroelectronics - All rights reserved



STMicroelectronics group of companies

Australia - Belgium - Brazil - Canada - China - Czech Republic - Finland - France - Germany - Hong Kong - India - Israel - Italy - Japan -
Malaysia - Malta - Morocco - Singapore - Spain - Sweden - Switzerland - United Kingdom - United States of America

www.st.com

Looking for pricing, stock, or lifecycle information?

Click below to explore more details on WIN SOURCE:

-  [View BUL3P5 on WIN SOURCE](#)
-  [STMicroelectronics](#) Information

Optimize Your Supply Chain with WIN SOURCE Solutions

-  Global Sourcing Solution
-  Obsolete Management
-  Cost Control Management
-  Shortage Management
-  Alternative Solution
-  Excess Inventory Management