



**THE DATASHEET OF
PSD4235G2-90U**





PSD4235G2

Flash in-system programmable (ISP)
for 16-bit MCUs (5 V supply)

Features

- Dual bank Flash memories
 - 4 Mbit of Primary Flash memory (8 uniform sectors, 32K x 16)
 - 256 Kbit Secondary Flash memory with 4 sectors
 - Concurrent operation: read from one memory while erasing and writing the other
- 64 Kbit SRAM
- PLD with macrocells
 - Over 3000 gates of PLD: CPLD and DPLD
 - CPLD with 16 output macrocells (OMCs) and 24 input macrocells (IMCs)
 - DPLD - user defined internal chip select decoding
- 7 L/O ports with 52 I/O pins
 - 52 individually configurable I/O port pins that can be used for the following functions:
 - MCU I/Os
 - PLD I/Os
 - Latched MCU address output
 - Special function I/Os
 - I/O ports may be configured as open-drain outputs
- In-system programming (ISP) with JTAG
 - Built-in JTAG compliant serial port allows full-chip In-System Programmability
 - Efficient manufacturing allow easy product testing and programming Use low cost FlashLINK cable with PC

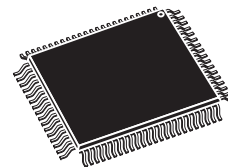

LQFP80 (U)
80-lead, Thin, Quad, Flat

- Page register
 - Internal page register that can be used to expand the microcontroller address space by a factor of 256
 - Programmable power management
- High endurance
 - 100,000 Erase/write cycles of Flash memory
 - 1,000 Erase/WRITE Cycles of PLD
 - 15 Year Data Retention
- Single supply voltage
 - 5V ±10%
- Memory speed
 - 70ns Flash memory and SRAM access time
- Packages are ECOPACK®

Contents

- 1 Summary description 12**
 - 1.1 In-system programming (ISP) via JTAG 12
 - 1.1.1 First time programming 12
 - 1.1.2 Inventory build-up of pre-programmed devices 12
 - 1.1.3 Expensive sockets 12
 - 1.2 In-application programming (IAP) 12
 - 1.2.1 Simultaneous READ and WRITE to Flash memory 13
 - 1.2.2 Complex memory mapping 13
 - 1.2.3 Separate Program and Data space 13
 - 1.3 PSDsoft™ Express 13
- 2 Pin description 16**
- 3 PSD architectural overview 21**
 - 3.1 Memory 21
 - 3.2 PLDs 21
 - 3.3 I/O ports 21
 - 3.4 MCU bus interface 22
 - 3.5 ISP via JTAG port 22
 - 3.6 In-System Programming (ISP) 22
 - 3.7 In-application programming (IAP) 22
 - 3.8 Page register 22
 - 3.9 Power management unit (PMU) 23
- 4 Development system 24**
- 5 PSD register description and address offsets 26**
- 6 Register bit definition 28**
 - 6.1 Data-In registers - port A, B, C, D, E, F, G 28
 - 6.2 Data-out registers - port A, B, C, D, E, F, G 28
 - 6.3 Direction registers - ports A, B, C, D, E, F, G 28
 - 6.4 Control registers 28

6.5	Drive registers - Ports A, B, D, E, G	29
6.6	Drive registers - Ports C and F	29
6.7	Enable-Out registers - Ports A, B, C, F	29
6.8	Input macrocells registers- ports A, B, C	29
6.9	Output macrocells A/B registers	30
6.10	Mask macrocells A/B registers	30
6.11	Flash Memory Protection register	30
6.12	Flash Boot Protection register	31
6.13	JTAG Enable register	31
6.14	Page register	31
6.15	PMMR0 register	31
6.16	PMMR2 register	32
6.17	VM register	33
6.18	Memory_ID0 registers	34
6.19	Memory_ID1 register	34
7	Detailed operation	35
7.1	Memory blocks	35
7.2	Primary Flash memory and Secondary Flash memory description	36
7.2.1	Memory block Select signals	36
7.2.2	Ready/Busy (PE4)	36
7.3	Memory operation	36
8	Instructions	39
8.1	Power-up condition	39
8.2	Reading Flash memory	40
8.3	Read memory contents	40
8.4	Read Primary Flash identifier	40
8.5	Read Memory Sector Protection status	40
8.6	Reading the Erase/Program status bits	40
8.7	Data Polling (DQ7) - DQ15 for Motorola	41
8.8	Toggle flag (DQ6) - DQ14 for Motorola	41
8.9	Error flag (DQ5) - DQ13 for Motorola	42
8.10	Erase timeout flag (DQ3) - DQ11 for Motorola	42

9	Programming Flash memory	43
9.1	Data polling	43
9.2	Data toggle	44
9.3	Unlock Bypass	45
10	Erasing Flash memory	47
10.1	Flash Bulk Erase	47
10.2	Suspend Sector Erase	48
10.3	Resume Sector Erase	48
11	Specific features	49
11.1	Flash Memory Sector Protect	49
11.2	Reset	49
11.3	Reset ($\overline{\text{RESET}}$) pin	49
12	SRAM	50
13	Memory Select signals	51
13.1	Example	51
13.2	Memory Select configuration for MCUs with separate Program and Data spaces	51
13.3	Separate space modes	52
13.4	Combined space modes	52
13.5	80C51XA memory map example	53
14	Page register	54
15	Memory ID registers	55
16	PLDS	56
17	Decode PLD (DPLD)	59
18	Complex PLD (CPLD)	61
18.1	Output macrocell (OMC)	62
18.2	Product Term Allocator	63

18.3	Loading and Reading the output macrocells (OMC)	64
18.4	The OMC Mask register	64
18.5	The output Enable of the OMC	64
18.6	Input macrocells (IMC)	65
18.7	External Chip Select	67
19	MCU bus interface	69
19.1	PSD interface to a multiplexed bus	70
19.2	PSD interface to a non-multiplexed 8-bit bus	71
19.3	Data Byte Enable reference	71
19.4	MCU bus interface examples	72
19.5	80C196 and 80C186	73
19.6	MC683xx and MC68HC16	74
19.7	80C51XA	75
19.8	H8/300	76
19.9	MMC2001	77
19.10	C16x family	77
20	I/O ports	80
20.1	General port architecture	80
20.2	Port operating modes	81
20.3	MCU I/O mode	82
20.4	PLD I/O mode	82
20.5	Address Out mode	82
20.6	Address In mode	84
20.7	Data Port mode	84
20.8	Peripheral I/O mode	84
20.9	JTAG in-system programming (ISP)	85
20.10	MCU Reset mode	85
20.11	Port Configuration registers (PCR)	86
20.12	Control register	86
20.13	Direction register	86
20.14	Port Data registers	88
20.15	Data In	88

20.16	Data Out register	88
20.17	Output macrocells (OMC)	88
20.18	Mask macrocell register	88
20.19	Input macrocells (IMC)	88
20.20	Enable Out	89
20.21	Ports A, B and C - functionality and structure	89
20.22	Port D - functionality and structure	90
20.23	Port E - functionality and structure	91
20.24	Port F - functionality and structure	92
20.25	Port G - functionality and structure	92
21	Power management	94
21.1	Automatic Power-down (APD) Unit and Power-down mode	95
21.2	Power-down mode	95
21.3	Other power saving options	96
21.4	PLD power management	96
21.5	PSD Chip Select input (CSI, PD2)	97
21.6	Input clock	97
21.7	Input control signals	98
22	Power-on Reset, Warm Reset and Power-down	99
22.1	Power-on Reset	99
22.2	Warm Reset	99
22.3	I/O pin, register and PLD status at Reset	99
22.4	Reset of Flash Memory Erase and Program cycles	99
23	Programming in-circuit using the JTAG serial interface	101
23.1	Standard JTAG signals	101
23.2	JTAG extensions	102
23.3	Security and Flash memory protection	102
24	Initial delivery state	104
25	Maximum rating	105

26	DC and AC parameters	106
27	Package mechanical	124
28	Part numbering	126
Appendix A	Pin assignments	127
29	Revision history	128

List of tables

Table 1.	Pin names	14
Table 2.	Pin description (for the LQFP package)	16
Table 3.	PLD I/O	22
Table 4.	JTAG signals on port E	22
Table 5.	Methods of programming different functional blocks of the PSD	23
Table 6.	Register address offset	26
Table 7.	Data-In registers - Ports A, B, C, D, E, F, G	28
Table 8.	Data-Out registers - Ports A, B, C, D, E, F, G	28
Table 9.	Direction registers - Ports A, B, C, D, E, F, G	28
Table 10.	Control registers - Ports E, F, G	28
Table 11.	Drive registers - Ports A, B, D, E, G	29
Table 12.	Drive registers - Ports C, F	29
Table 13.	Enable-Out registers - Ports A, B, C, F	29
Table 14.	Input macrocell registers - Port A, B, C	29
Table 15.	Output macrocells A register	30
Table 16.	Output macrocells B register	30
Table 17.	Mask macrocells A register	30
Table 18.	Mask macrocells B register	30
Table 19.	Flash Memory Protection register	30
Table 20.	Flash Boot Protection register	31
Table 21.	JTAG Enable register	31
Table 22.	Page register	31
Table 23.	PMMR0 register	31
Table 24.	PMMR2 register	32
Table 25.	VM register	33
Table 26.	Memory_ID0 register	34
Table 27.	Memory_ID1 register	34
Table 28.	Memory block size and organization	35
Table 29.	Instructions	37
Table 30.	Status bits	41
Table 31.	Status bits for Motorola	41
Table 32.	DPLD and CPLD inputs	56
Table 33.	Output macrocell Port and Data bit Assignments	63
Table 34.	MCUs and their control signals	69
Table 35.	16-bit data bus with BHE	71
Table 36.	16-bit data bus with WRH and WRL	72
Table 37.	16-bit data bus with SIZ0, A0 (Motorola MCU)	72
Table 38.	16-bit data bus with LDS, UDS (Motorola MCU)	72
Table 39.	Port operating modes	82
Table 40.	Port operating mode settings	83
Table 41.	I/O port latched address output assignments	84
Table 42.	Port Configuration registers (PCR)	86
Table 43.	Port Pin Direction Control, output Enable P.T. not defined	87
Table 44.	Port Pin Direction Control, output Enable P.T. defined	87
Table 45.	Port direction assignment example	87
Table 46.	Drive register pin assignment	87
Table 47.	Port Data registers	88
Table 48.	Effect of Power-down mode on ports	95

Table 49.	PSD timing and standby current during Power-down mode	96
Table 50.	APD counter operation	98
Table 51.	Status During Power-On Reset, Warm Reset and Power-down mode	99
Table 52.	JTAG port signals	102
Table 53.	Absolute maximum ratings	105
Table 54.	Example of PSD typical power calculation at $V_{CC} = 5.0V$ (with Turbo mode on)	107
Table 55.	Example of PSD typical power calculation at $V_{CC} = 5.0V$ (with Turbo mode off)	108
Table 56.	Operating conditions	109
Table 57.	AC signal letters for PLD timings	109
Table 58.	AC signal behavior symbols for PLD timings	109
Table 59.	AC measurement conditions	110
Table 60.	Capacitance	110
Table 61.	DC characteristics	111
Table 62.	CPLD Combinatorial timing	112
Table 63.	CPLD macrocell Synchronous clock mode timing	113
Table 64.	CPLD macrocell Asynchronous clock mode timing	114
Table 65.	Input macrocell timing	115
Table 66.	Program, WRITE and Erase times	116
Table 67.	READ timing	117
Table 68.	WRITE timing	119
Table 69.	Port F Peripheral Data Mode Read timing	121
Table 70.	Port F Peripheral Data Mode Write timing	121
Table 71.	Reset (\overline{RESET}) timing	121
Table 72.	Power-down timing	122
Table 73.	ISC timing	123
Table 74.	LQFP80 - 80-lead plastic thin, quad, flat package mechanical data	124
Table 75.	Ordering information scheme	126
Table 76.	PSD4235G2 LQFP80	127
Table 77.	Document revision history	128

List of figures

Figure 1.	Logic diagram	14
Figure 2.	LQFP connections	15
Figure 3.	PSD block diagram	20
Figure 4.	PSDsoft Express development tool	25
Figure 5.	Data polling flowchart	44
Figure 6.	Data toggle flowchart	46
Figure 7.	Priority level of memory and I/O components	52
Figure 8.	8031 memory modules - separate space	53
Figure 9.	8031 memory modules - combined space	53
Figure 10.	Page register	54
Figure 11.	PLD diagram	58
Figure 12.	DPLD logic array	60
Figure 13.	Macrocell and I/O port	62
Figure 14.	CPLD output macrocell	65
Figure 15.	Input macrocell	66
Figure 16.	External Chip Select signal	67
Figure 17.	Handshaking communication using input macrocells	68
Figure 18.	An example of a typical 16-bit multiplexed bus interface	70
Figure 19.	An example of a typical 16-bit non-multiplexed bus interface	71
Figure 20.	Interfacing the PSD with an 80C196	73
Figure 21.	Interfacing the PSD with an MC68331	74
Figure 22.	Interfacing the PSD with an 80C51XA-G3	75
Figure 23.	Interfacing the PSD with an H83/2350	76
Figure 24.	Interfacing the PSD with an MMC2001	78
Figure 25.	Interfacing the PSD with a C167CR	79
Figure 26.	General I/O port architecture	81
Figure 27.	Peripheral I/O mode	85
Figure 28.	Port A, B and C structure	90
Figure 29.	Port D structure	91
Figure 30.	Port E, F and G structure	93
Figure 31.	APD unit	96
Figure 32.	Enable Power-down flowchart	97
Figure 33.	Reset (RESET) timing	100
Figure 34.	PLD ICC /frequency consumption	106
Figure 35.	AC measurement I/O waveform	110
Figure 36.	AC measurement load circuit	110
Figure 37.	Switching waveforms - key	111
Figure 38.	Input to output Disable/Enable	112
Figure 39.	Synchronous clock mode timing - PLD	114
Figure 40.	Asynchronous $\overline{\text{RESET}}$ / Preset	115
Figure 41.	Asynchronous clock mode timing (product term clock)	115
Figure 42.	Input macrocell timing (product term clock)	115
Figure 43.	Peripheral I/O write timing	116
Figure 44.	READ timing	117
Figure 45.	WRITE timing	119
Figure 46.	Peripheral I/O read timing	120
Figure 47.	Reset ($\overline{\text{RESET}}$) timing	121
Figure 48.	ISC timing	122

Figure 49. LQFP80 - 80-lead plastic thin, quad, flat package outline 124

1 Summary description

The PSD family of memory systems for microcontrollers (MCUs) brings In-System-Programmability (ISP) to Flash memory and programmable logic. The result is a simple and flexible solution for embedded designs. PSD devices combine many of the peripheral functions found in MCU based applications.

PSD devices integrate an optimized macrocell logic architecture. The macrocell was created to address the unique requirements of embedded system designs. It allows direct connection between the system address/data bus, and the internal PSD registers, to simplify communication between the MCU and other supporting devices.

The PSD family offers two methods to program the PSD Flash memory while the PSD is soldered to the circuit board:

1.1 In-system programming (ISP) via JTAG

An IEEE 1149.1 compliant JTAG in-system programming (ISP) interface is included on the PSD enabling the entire device (Flash memories, PLD, configuration) to be rapidly programmed while soldered to the circuit board. This requires no MCU participation, which means the PSD can be programmed anytime, even when completely blank.

The innovative JTAG interface to Flash memories is an industry first, solving key problems faced by designers and manufacturing houses, such as:

1.1.1 First time programming

How do I get firmware into the Flash memory the very first time? JTAG is the answer. Program the blank PSD with no MCU involvement.

1.1.2 Inventory build-up of pre-programmed devices

How do I maintain an accurate count of pre-programmed Flash memory and PLD devices based on customer demand? How many and what version? JTAG is the answer. Build your hardware with blank PSDs soldered directly to the board and then custom program just before they are shipped to the customer. No more labels on chips, and no more wasted inventory.

1.1.3 Expensive sockets

How do I eliminate the need for expensive and unreliable sockets? JTAG is the answer. Solder the PSD directly to the circuit board. Program first time and subsequent times with JTAG. No need to handle devices and bend the fragile leads.

1.2 In-application programming (IAP)

Two independent Flash memory arrays are included so that the MCU can execute code from one while erasing and programming the other. Robust product firmware updates in the field are possible over any communication channel (CAN, Ethernet, UART, J1850, etc) using this unique architecture. Designers are relieved of these problems:

1.2.1 Simultaneous READ and WRITE to Flash memory

How can the MCU program the same memory from which it executing code? It cannot. The PSD allows the MCU to operate the two Flash memory blocks concurrently, reading code from one while erasing and programming the other during IAP.

1.2.2 Complex memory mapping

How can I map these two memories efficiently? A programmable Decode PLD (DPLD) is embedded in the PSD. The concurrent PSD memories can be mapped anywhere in MCU address space, segment by segment with extremely high address resolution. As an option, the secondary Flash memory can be swapped out of the system memory map when IAP is complete. A built-in page register breaks the MCU address limit.

1.2.3 Separate Program and Data space

How can I write to Flash memory while it resides in Program space during field firmware updates? My 80C51XA will not allow it. The PSD provides means to reclassify Flash memory as Data space during IAP, then back to Program space when complete.

1.3 PSDsoft™ Express

PSDsoft Express, a software development tool from ST, guides you through the design process step-by-step making it possible to complete an embedded MCU design capable of ISP/IAP in just hours. Select your MCU and PSDsoft Express takes you through the remainder of the design with point and click entry, covering PSD selection, pin definitions, programmable logic inputs and output, MCU memory map definition, ANSI-C code generation for your MCU, and merging your MCU firmware with the PSD design. When complete, two different device programmers are supported directly from PSDsoft Express: FlashLINK (JTAG) and PSDpro.

Figure 1. Logic diagram

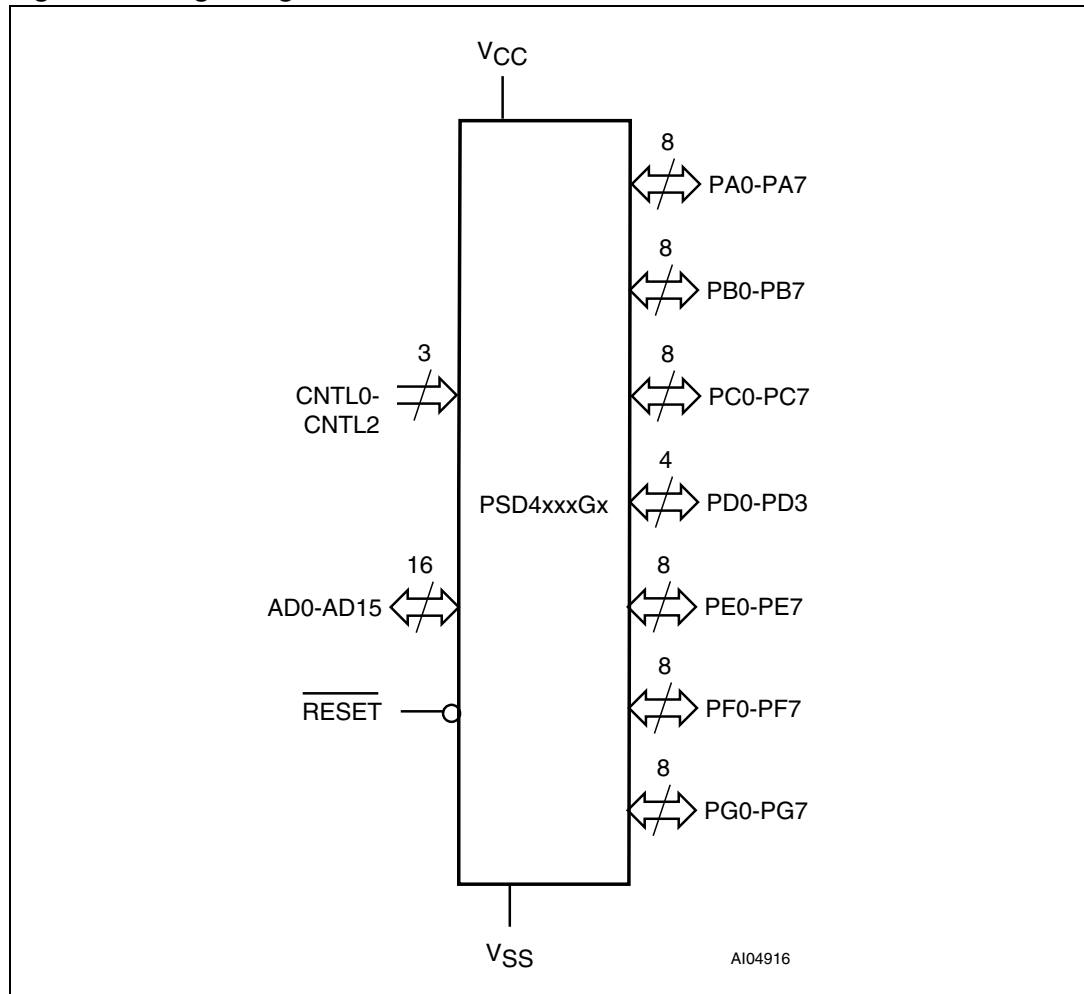

Table 1. Pin names

Pin	Description
PA0-PA7	Port-A
PB0-PB7	Port-B
PC0-PC7	Port-C
PD0-PD3	Port-D
PE0-PE7	Port-E
PF0-PF7	Port-F
PG0-PG7	Port-G
AD0-AD15	Address/Data
CNTL0-CNTL2	Control
RESET	Reset

Table 1. Pin names (continued)

Pin	Description
V _{CC}	Supply voltage
V _{SS}	Ground

Figure 2. LQFP connections

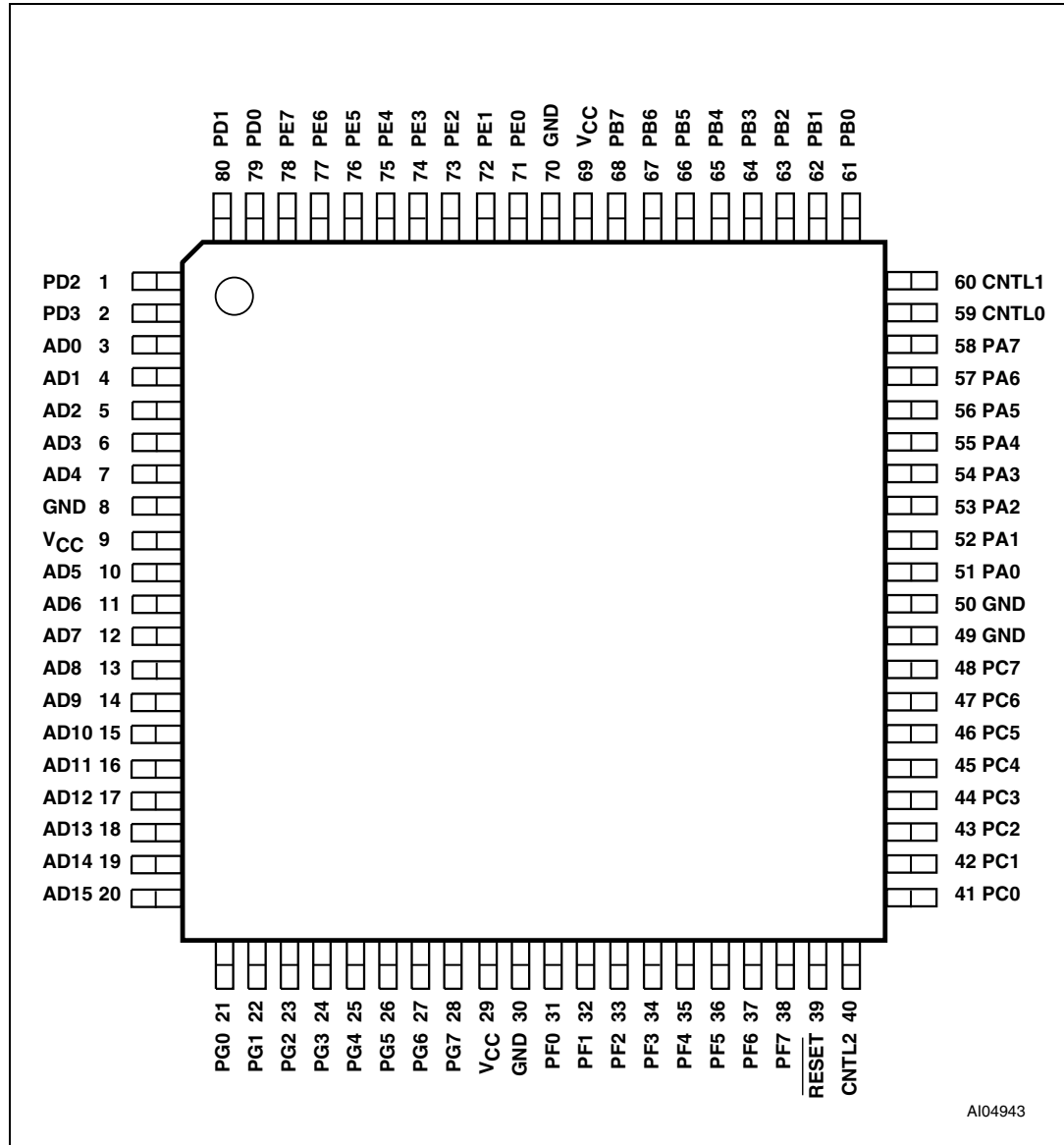

2 Pin description

Table 2. Pin description (for the LQFP package)

Pin name	Pin	Type	Description
ADIO0-ADIO7	3-7 10-12	I/O	<p>This is the lower Address/Data port. Connect your MCU address or address/data bus according to the following rules:</p> <ol style="list-style-type: none"> 1. If your MCU has a multiplexed address/data bus where the data is multiplexed with the lower address bits, connect AD0-AD7 to this port. 2. If your MCU does not have a multiplexed address/data bus, connect A0-A7 to this port. 3. If you are using an 80C51XA in burst mode, connect A4/D0 through A11/D7 to this port. <p>ALE or AS latches the address. The PSD drives data out only if the READ signal is active and one of the PSD functional blocks has been selected. The addresses on this port are passed to the PLDs.</p>
ADIO8-ADIO15	13-20	I/O	<p>This is the upper Address/Data port. Connect your MCU address or address/data bus according to the following rules:</p> <ol style="list-style-type: none"> 1. If your MCU has a multiplexed address/data bus where the data is multiplexed with the upper address bits, connect A8-A15 to this port. 2. If your MCU does not have a multiplexed address/data bus, connect A8-A15 to this port. 3. If you are using an 80C51XA in burst mode, connect A12/D8 through A19/D15 to this port. <p>ALE or AS latches the address. The PSD drives data out only if the READ signal is active and one of the PSD functional blocks has been selected. The addresses on this port are passed to the PLDs.</p>
CNTL0	59	I	<p>The following control signals can be connected to this pin, based on your MCU:</p> <ol style="list-style-type: none"> 1. \overline{WR} - active low, Write Strobe input. 2. R_W - active high, READ/active low WRITE input. 3. \overline{WRL} - active low, WRITE to low-byte. <p>This pin is connected to the PLDs. Therefore, these signals can be used in decode and other logic equations.</p>
CNTL1	60	I	<p>The following control signals can be connected to this pin, based on your MCU:</p> <ol style="list-style-type: none"> 1. \overline{RD} - active low, Read Strobe input. 2. E - E clock input. 3. \overline{DS} - active low, Data Strobe input. 4. \overline{LDS} - active low, Strobe for low data byte. <p>This pin is connected to the PLDs. Therefore, these signals can be used in decode and other logic equations.</p>

Table 2. Pin description (for the LQFP package) (continued)

Pin name	Pin	Type	Description
CNTL2	40	I	<p>READ or other Control input pin, with multiple configurations. Depending on the MCU interface selected, this pin can be:</p> <ol style="list-style-type: none"> 1. \overline{PSEN} - Program Select Enable, active low in code fetch bus cycle (80C51XA mode). 2. BHE - high-byte enable, 16-bit data bus. 3. \overline{UDS} - active low, Strobe for high data byte, 16-bit data bus mode. 4. SIZ0 - Byte enable input. 5. LSTRB - low Strobe input. <p>This pin is also connected to the PLDs.</p>
\overline{RESET}	39	I	<p>Active low input. Resets I/O Ports, PLD macrocells and some of the Configuration registers and JTAG registers. Must be low at Power-up. Reset also aborts any Flash memory Program or Erase cycle that is currently in progress.</p>
PA0-PA7	51-58	I/O CMOS or Open Drain	<p>These pins make up Port A. These port pins are configurable and can have the following functions:</p> <ol style="list-style-type: none"> 1. MCU I/O - standard output or input port. 2. CPLD macrocell (McellA0-McellA7) outputs. 3. Latched, transparent or registered PLD inputs (can also be PLD input for address A16 and above).
PB0-PB7	61-68	I/O CMOS or Open Drain	<p>These pins make up Port B. These port pins are configurable and can have the following functions:</p> <ol style="list-style-type: none"> 1. MCU I/O - standard output or input port. 2. CPLD macrocell (McellB0-McellB7) outputs. 3. Latched, transparent or registered PLD inputs (can also be PLD input for address A16 and above).
PC0-PC7	41-48	I/O CMOS or Slew Rate	<p>These pins make up Port C. These port pins are configurable and can have the following functions:</p> <ol style="list-style-type: none"> 1. MCU I/O - standard output or input port. 2. External Chip Select (ECS0-ECS7) outputs. 3. Latched, transparent or registered PLD inputs (can also be PLD input for address A16 and above).
PD0	79	I/O CMOS or Open Drain	<p>PD0 pin of Port D. This port pin can be configured to have the following functions:</p> <ol style="list-style-type: none"> 1. ALE/AS input - latches address on ADIO0-ADIO15. 2. \overline{AS} input - latches address on ADIO0-ADIO15 on the rising edge. 3. MCU I/O - standard output or input port. 4. Transparent PLD input (can also be PLD input for address A16 and above).
PD1	80	I/O CMOS or Open Drain	<p>PD1 pin of Port D. This port pin can be configured to have the following functions:</p> <ol style="list-style-type: none"> 1. MCU I/O - standard output or input port. 2. Transparent PLD input (can also be PLD input for address A16 and above). 3. CLKIN - clock input to the CPLD macrocells, the APD Unit's Power-down counter, and the CPLD AND Array.

Table 2. Pin description (for the LQFP package) (continued)

Pin name	Pin	Type	Description
PD2	1	I/O CMOS or Open Drain	PD2 pin of Port D. This port pin can be configured to have the following functions: 1. MCU I/O - standard output or input port. 2. Transparent PLD input (can also be PLD input for address A16 and above). 3. PSD Chip Select input ($\overline{\text{CSI}}$). When low, the MCU can access the PSD memory and I/O. When high, the PSD memory blocks are disabled to conserve power. The falling edge of this signal can be used to get the device out of Power-down mode.
PD3	2	I/O CMOS or Open Drain	PD3 pin of Port D. This port pin can be configured to have the following functions: 1. MCU I/O - standard output or input port. 2. Transparent PLD input (can also be PLD input for address A16 and above). 3. $\overline{\text{WRH}}$ - for 16-bit data bus, WRITE to high byte, active low.
PE0	71	I/O CMOS or Open Drain	PE0 pin of Port E. This port pin can be configured to have the following functions: 1. MCU I/O - standard output or input port. 2. Latched address output. 3. TMS input for the JTAG Serial Interface.
PE1	72	I/O CMOS or Open Drain	PE1 pin of Port E. This port pin can be configured to have the following functions: 1. MCU I/O - standard output or input port. 2. Latched address output. 3. TCK input for the JTAG Serial Interface.
PE2	73	I/O CMOS or Open Drain	PE2 pin of Port E. This port pin can be configured to have the following functions: 1. MCU I/O - standard output or input port. 2. Latched address output. 3. TDI input for the JTAG Serial Interface.
PE3	74	I/O CMOS or Open Drain	PE3 pin of Port E. This port pin can be configured to have the following functions: 1. MCU I/O - standard output or input port. 2. Latched address output. 3. TDO output for the JTAG Serial Interface.
PE4	75	I/O CMOS or Open Drain	PE4 pin of Port E. This port pin can be configured to have the following functions: 1. MCU I/O - standard output or input port. 2. Latched address output. 3. TSTAT output for the JTAG Serial Interface. 4. Ready/ $\overline{\text{Busy}}$ output for parallel in-system programming (ISP).
PE5	76	I/O CMOS or Open Drain	PE5 pin of Port E. This port pin can be configured to have the following functions: 1. MCU I/O - standard output or input port. 2. Latched address output. 3. $\overline{\text{TERR}}$ active low output for the JTAG Serial Interface.
PE6	77	I/O CMOS or Open Drain	PE6 pin of Port E. This port pin can be configured to have the following functions: 1. MCU I/O - standard output or input port. 2. Latched address output.

Table 2. Pin description (for the LQFP package) (continued)

Pin name	Pin	Type	Description
PE7	78	I/O CMOS or Open Drain	PE7 pin of Port E. This port pin can be configured to have the following functions: 1. MCU I/O - standard output or input port. 2. Latched address output.
PF0-PF7	31-38	I/O CMOS or Open Drain	These pins make up Port F. These port pins are configurable and can have the following functions: 1. MCU I/O - standard output or input port. 2. External Chip Select (ECS0-ECS7) outputs, or inputs to CPLD. 3. Latched address outputs. 4. Address A1-A3 inputs in 80C51XA mode (PF0 is grounded) 5. Data bus port (D0-D7) in a non-multiplexed bus configuration. 6. Peripheral I/O mode. 7. MCU reset mode.
PG0-PG7	21-28	I/O CMOS or Open Drain	These pins make up Port G. These port pins are configurable and can have the following functions: 1. MCU I/O - standard output or input port. 2. Latched address outputs. 3. Data bus port (D8-D15) in a non-multiplexed bus configuration. 4. MCU reset mode.
V _{CC}	9, 29, 69		Supply voltage
GND	8, 30, 49, 50, 70		Ground pins

Figure 3. PSD block diagram

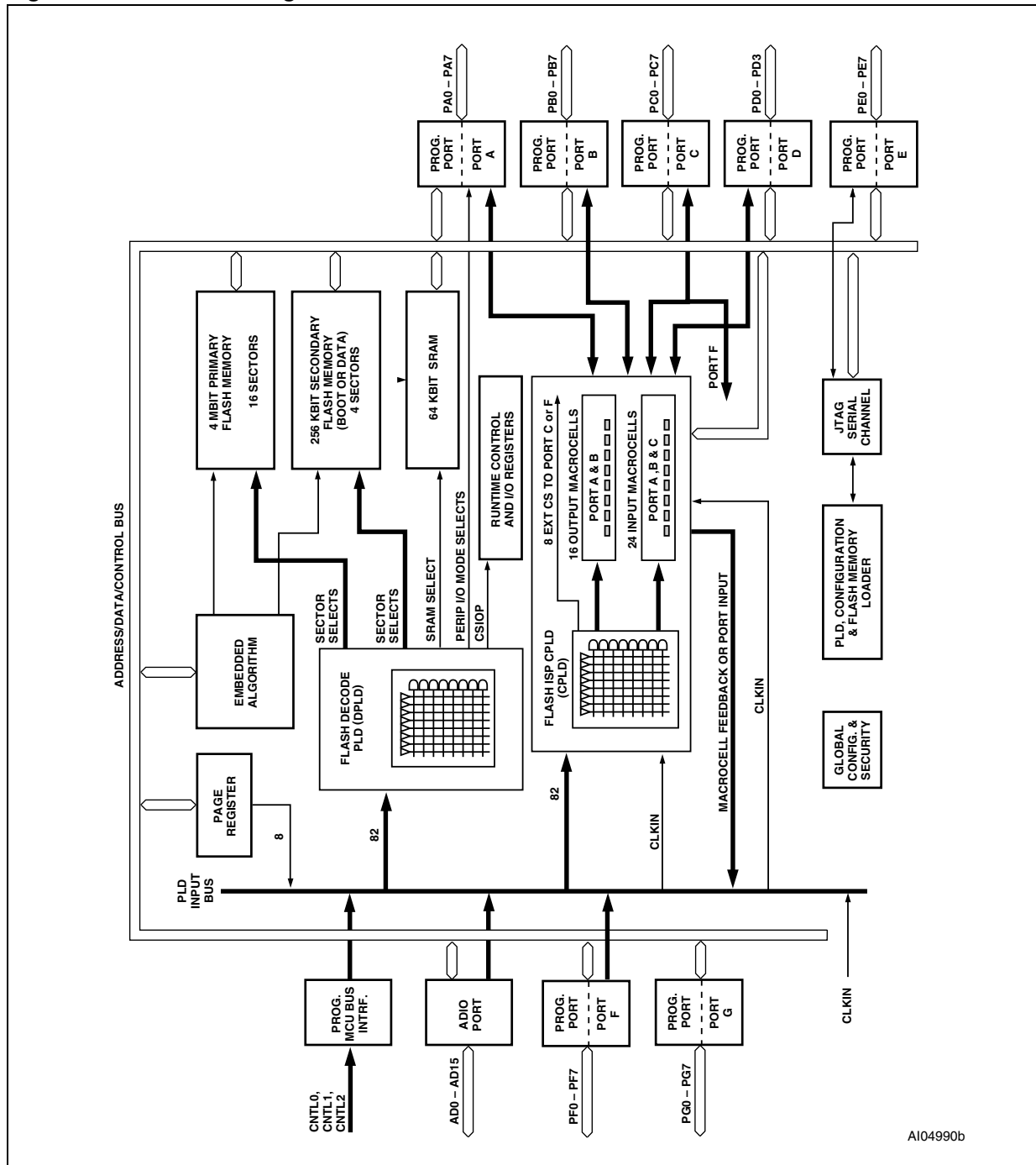

AI04990b

1. Additional address lines can be brought in to the device via Port A, B, C, D or F.

3 PSD architectural overview

PSD devices contain several major functional blocks. [Figure 3](#) shows the architecture of the PSD device family. The functions of each block are described briefly in the following sections. Many of the blocks perform multiple functions and are user configurable.

3.1 Memory

Each of the memory blocks is briefly discussed in the following paragraphs. A more detailed discussion can be found in [Section 7.1: Memory blocks on page 35](#).

The 4 Mbit primary Flash memory is the main memory of the PSD. It is divided into 8 equally-sized sectors that are individually selectable.

The 256 Kbit secondary Flash memory is divided into 4 equally-sized sectors. Each sector is individually selectable.

The 64 Kbit SRAM is intended for use as a scratch-pad memory or as an extension to the MCU SRAM.

Each memory block can be located in a different address space as defined by the user. The access times for all memory types includes the address latching and DPLD decoding time.

3.2 PLDs

The device contains two PLD blocks, the Decode PLD (DPLD) and the Complex PLD (CPLD), as shown in [Table 3](#), each optimized for a different function. The functional partitioning of the PLDs reduces power consumption, optimizes cost/performance, and eases design entry.

The DPLD is used to decode addresses and to generate Sector Select signals for the PSD internal memory and registers. The DPLD has combinatorial outputs, while the CPLD can implement more general user-defined logic functions. The CPLD has 16 output macrocells (OMC) and 8 combinatorial outputs. The PSD also has 24 input macrocells (IMC) that can be configured as inputs to the PLDs. The PLDs receive their inputs from the PLD input Bus and are differentiated by their output destinations, number of product terms, and macrocells.

The PLDs consume minimal power. The speed and power consumption of the PLD is controlled by the Turbo bit in PMMR0 and other bits in PMMR2. These registers are set by the MCU at run-time. There is a slight penalty to PLD propagation time when not in the Turbo mode.

3.3 I/O ports

The PSD has 52 I/O pins divided among seven ports (Port A, B, C, D, E, F and G). Each I/O pin can be individually configured for different functions. Ports can be configured as standard MCU I/O ports, PLD I/O, or latched address outputs for MCUs using multiplexed address/data buses

The JTAG pins can be enabled on Port E for in-system programming (ISP).

3.4 MCU bus interface

The PSD easily interfaces easily with most 16-bit MCUs, either with multiplexed or non-multiplexed address/data buses. The device is configured to respond to the MCU's control pins, which are also used as inputs to the PLDs.

3.5 ISP via JTAG port

In-System Programming (ISP) can be performed through the JTAG signals on Port E. This serial interface allows complete programming of the entire PSD device. A blank device can be completely programmed. The JTAG signals (TMS, TCK, TSTAT, $\overline{\text{TERR}}$, TDI, TDO) can be multiplexed with other functions on Port E. [Table 4](#) indicates the JTAG pin assignments.

Table 3. PLD I/O

Name	Inputs	Outputs	Product Terms
Decode PLD (DPLD)	82	17	43
Complex PLD (CPLD)	82	24	150

Table 4. JTAG signals on port E

Port E pins	JTAG signal
PE0	TMS
PE1	TCK
PE2	TDI
PE3	TDO
PE4	TSTAT
PE5	TERR

3.6 In-System Programming (ISP)

Using the JTAG signals on Port E, the entire PSD device (memory, logic, configuration) can be programmed or erased without the use of the MCU.

3.7 In-application programming (IAP)

The primary Flash memory can also be programmed, or re-programmed, in-system by the MCU executing the programming algorithms out of the secondary Flash memory, or SRAM. The secondary Flash memory can be programmed the same way by executing out of the primary Flash memory. [Table 5](#) indicates which programming methods can program different functional blocks of the PSD.

3.8 Page register

The 8-bit Page register expands the address range of the MCU by up to 256 times. The paged address can be used as part of the address space to access external memory and

peripherals, or internal memory and I/O. The Page register can also be used to change the address mapping of the Flash memory blocks into different memory spaces for IAP.

3.9 Power management unit (PMU)

The power management unit (PMU) gives the user control of the power consumption on selected functional blocks based on system requirements. The PMU includes an Automatic Power-down (APD) Unit that turns off device functions during MCU inactivity. The APD Unit has a Power-down mode that helps reduce power consumption.

The PSD also has some bits that are configured at run-time by the MCU to reduce power consumption of the CPLD. The Turbo bit in PMMR0 can be reset to '0' and the CPLD latches its outputs and goes to Standby mode until the next transition on its inputs.

Additionally, bits in PMMR2 can be set by the MCU to block signals from entering the CPLD to reduce power consumption. See [Section 21: Power management on page 94](#) for more details.

Table 5. Methods of programming different functional blocks of the PSD

Functional block	JTAG-ISP	Device programmer	IAP
Primary Flash memory	Yes	Yes	Yes
Secondary Flash memory	Yes	Yes	Yes
PLD Array (DPLD and CPLD)	Yes	Yes	No
PSD configuration	Yes	Yes	No

4 Development system

The PSD family is supported by PSDsoft Express, a Windows-based software development tool (Windows-95, Windows-98, Windows-2000, Windows-NT). A PSD design is quickly and easily produced in a point and click environment. The designer does not need to enter Hardware Description Language (HDL) equations, unless desired, to define PSD pin functions and memory map information. The general design flow is shown in [Figure 4](#). PSDsoft Express is available from our web site (the address is given on the back page of this data sheet) or other distribution channels.

PSDsoft Express directly supports two low cost device programmers from ST: PSDpro and FlashLINK (JTAG). Both of these programmers may be purchased through your local distributor/representative, or directly from our web site using a credit card. The PSD is also supported by third party device programmers. See our web site for the current list.

Figure 4. PSDsoft Express development tool

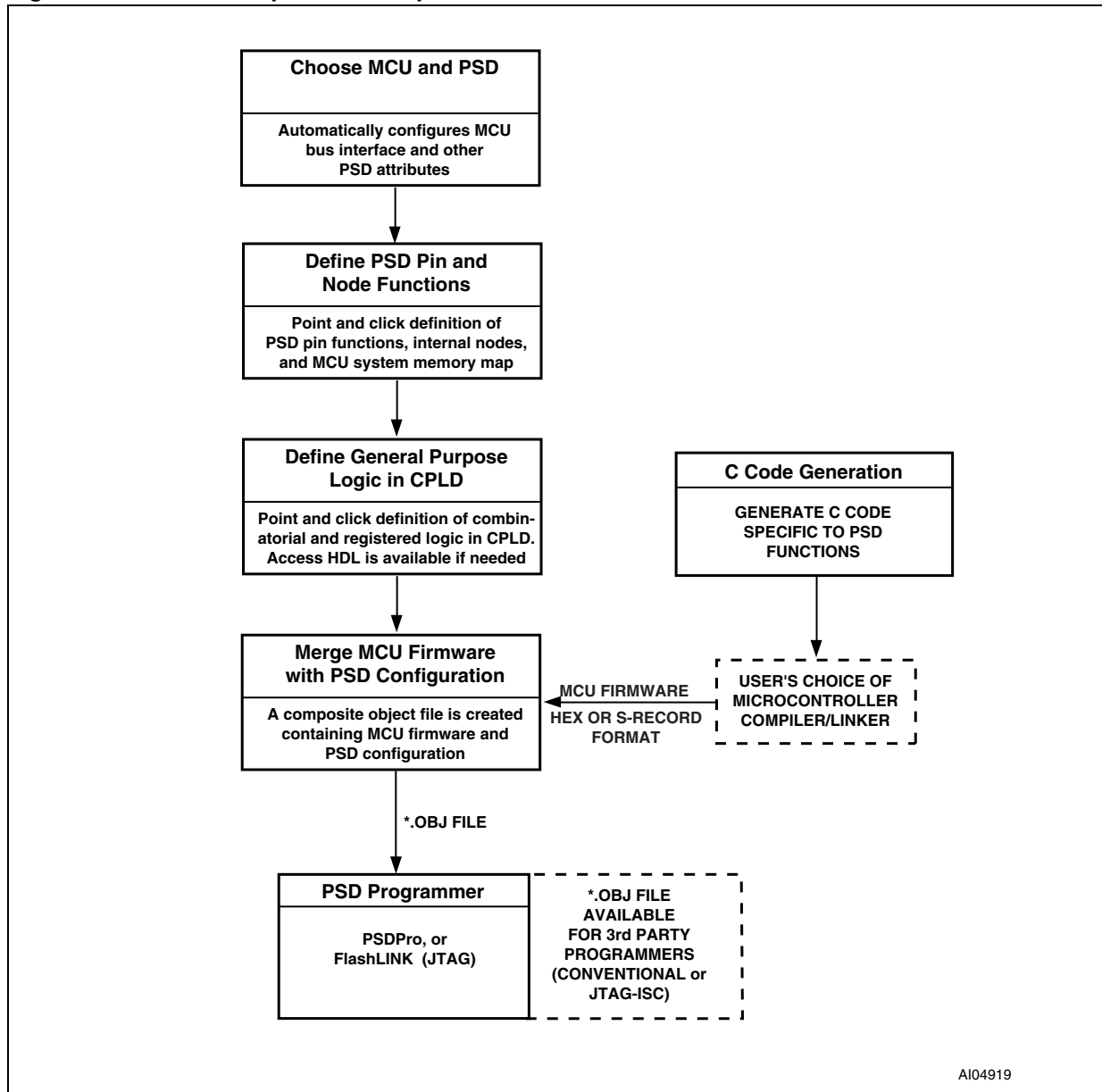

AI04919

5 PSD register description and address offsets

Table 6 shows the offset addresses to the PSD registers relative to the CSIOP base address. The CSIOP space is the 256 bytes of address that is allocated by the user to the internal PSD registers. *Table 6* provides brief descriptions of the registers in CSIOP space. The following sections give a more detailed description.

Table 6. Register address offset

Register name	Port A	Port B	Port C	Port D	Port E	Port F	Port G	Other ⁽¹⁾	Description
Data In	00	01	10	11	30	40	41		Reads Port pin as input, MCU I/O input mode
Control					32	42	43		Selects mode between MCU I/O or Address Out
Data Out	04	05	14	15	34	44	45		Stores data for output to Port pins, MCU I/O output mode
Direction	06	07	16	17	36	46	47		Configures Port pin as input or output
Drive Select	08	09	18	19	38	48	49		Configures Port pins as either CMOS or Open Drain on some pins, while selecting high slew rate on other pins.
Input macrocell	0A	0B		1A					Reads input macrocells
Enable Out	0C	0D	1C			4C			Reads the status of the output enable to the I/O Port driver
Output macrocells A	20								READ - reads output of macrocells A WRITE - loads macrocell Flip-flops
Output macrocells B		21							READ - reads output of macrocells B WRITE - loads macrocell Flip-flops
Mask macrocells A	22								Blocks writing to the output macrocells A
Mask macrocells B		23							Blocks writing to the output macrocells B
Flash Memory Protection								C0	Read only - Primary Flash Sector Protection
Flash Boot Protection								C2	Read only - PSD Security and Secondary Flash memory Sector Protection
JTAG Enable								C7	Enables JTAG Port
PMMR0								B0	Power Management register 0
PMMR2								B4	Power Management register 2
Page								E0	Page register
VM								E2	Places PSD memory areas in Program and/or Data space on an individual basis.

Table 6. Register address offset (continued)

Register name	Port A	Port B	Port C	Port D	Port E	Port F	Port G	Other ⁽¹⁾	Description
Memory_ID0								F0	Read only - SRAM and Primary memory size
Memory_ID1								F1	Read only - Secondary memory type and size

1. Other registers that are not part of the I/O ports.

6 Register bit definition

All the registers of the PSD are included here, for reference. Detailed descriptions of these registers can be found in the following sections.

6.1 Data-In registers - port A, B, C, D, E, F, G

Read Port pin status when Port is in MCU I/O input mode.

Read-only registers.

Table 7. Data-In registers - Ports A, B, C, D, E, F, G

Bit 7	Bit 6	Bit 5	Bit 4	Bit 3	Bit 2	Bit 1	Bit 0
Port pin 7	Port pin 6	Port pin 5	Port pin 4	Port pin 3	Port pin 2	Port pin 1	Port pin 0

6.2 Data-out registers - port A, B, C, D, E, F, G

Latched data for output to Port pin when pin is configured in MCU I/O output mode.

Table 8. Data-Out registers - Ports A, B, C, D, E, F, G

Bit 7	Bit 6	Bit 5	Bit 4	Bit 3	Bit 2	Bit 1	Bit 0
Port pin 7	Port pin 6	Port pin 5	Port pin 4	Port pin 3	Port pin 2	Port pin 1	Port pin 0

6.3 Direction registers - ports A, B, C, D, E, F, G

Table 9. Direction registers - Ports A, B, C, D, E, F, G

Bit 7	Bit 6	Bit 5	Bit 4	Bit 3	Bit 2	Bit 1	Bit 0
Port pin 7	Port pin 6	Port pin 5	Port pin 4	Port pin 3	Port pin 2	Port pin 1	Port pin 0

Port pin <i>:

0: Port pin <i> is configured in input mode (default).

1: Port pin <i> is configured in output mode.

6.4 Control registers

Table 10. Control registers - Ports E, F, G

Bit 7	Bit 6	Bit 5	Bit 4	Bit 3	Bit 2	Bit 1	Bit 0
Port pin 7	Port pin 6	Port pin 5	Port pin 4	Port pin 3	Port pin 2	Port pin 1	Port pin 0

Port pin <i>:

0: Port pin <i> is configured in MCU I/O mode (default).

1: Port pin <i> is configured in Latched Address Out mode.

6.5 Drive registers - Ports A, B, D, E, G

Table 11. Drive registers - Ports A, B, D, E, G

Bit 7	Bit 6	Bit 5	Bit 4	Bit 3	Bit 2	Bit 1	Bit 0
Port pin 7	Port pin 6	Port pin 5	Port pin 4	Port pin 3	Port pin 2	Port pin 1	Port pin 0

Port pin <i>:

- 0: Port pin <i> is configured for CMOS output driver (default).
- 1: Port pin <i> is configured for Open Drain output driver.

6.6 Drive registers - Ports C and F

Table 12. Drive registers - Ports C, F

Bit 7	Bit 6	Bit 5	Bit 4	Bit 3	Bit 2	Bit 1	Bit 0
Port pin 7	Port pin 6	Port pin 5	Port pin 4	Port pin 3	Port pin 2	Port pin 1	Port pin 0

Port pin <i>:

- 0: Port pin <i> is configured for CMOS output driver (default).
- 1: Port pin <i> is configured in Slew Rate mode.

6.7 Enable-Out registers - Ports A, B, C, F

Read-only registers

Table 13. Enable-Out registers - Ports A, B, C, F

Bit 7	Bit 6	Bit 5	Bit 4	Bit 3	Bit 2	Bit 1	Bit 0
Port pin 7	Port pin 6	Port pin 5	Port pin 4	Port pin 3	Port pin 2	Port pin 1	Port pin 0

Port pin <i>:

- 0: Port pin <i> is in tri-state driver (default).
- 1: Port pin <i> is enabled.

6.8 Input macrocells registers- ports A, B, C

Read input macrocell (IMC7-IMC0) status on Ports A, B and C.

Read-only registers

Table 14. Input macrocell registers - Port A, B, C

Bit 7	Bit 6	Bit 5	Bit 4	Bit 3	Bit 2	Bit 1	Bit 0
IMcell 7	IMcell 6	IMcell 5	IMcell 4	IMcell 3	IMcell 2	IMcell 1	IMcell 0

6.9 Output macrocells A/B registers

Write register: Load MCellA7-MCellA0/MCellB7-MCellB0 with 0 or 1.

Read register: Read MCellA7-MCellA0/MCellB7-MCellB0 output status.

Table 15. Output macrocells A register

Bit 7	Bit 6	Bit 5	Bit 4	Bit 3	Bit 2	Bit 1	Bit 0
Mcella 7	Mcella 6	Mcella 5	Mcella 4	Mcella 3	Mcella 2	Mcella 1	Mcella 0

Table 16. Output macrocells B register

Bit 7	Bit 6	Bit 5	Bit 4	Bit 3	Bit 2	Bit 1	Bit 0
Mcellb 7	Mcellb 6	Mcellb 5	Mcellb 4	Mcellb 3	Mcellb 2	Mcellb 1	Mcellb 0

6.10 Mask macrocells A/B registers

Table 17. Mask macrocells A register

Bit 7	Bit 6	Bit 5	Bit 4	Bit 3	Bit 2	Bit 1	Bit 0
Mcella 7	Mcella 6	Mcella 5	Mcella 4	Mcella 3	Mcella 2	Mcella 1	Mcella 0

Table 18. Mask macrocells B register

Bit 7	Bit 6	Bit 5	Bit 4	Bit 3	Bit 2	Bit 1	Bit 0
Mcellb 7	Mcellb 6	Mcellb 5	Mcellb 4	Mcellb 3	Mcellb 2	Mcellb 1	Mcellb 0

McellA<i>_Prot:

- 0: Allow MCellA<i>/MCellB<i> flip-flop to be loaded by MCU (default).
- 1: Prevent MCellA<i>/MCellB<i> flip-flop from being loaded by MCU.

6.11 Flash Memory Protection register

Read-only register

Table 19. Flash Memory Protection register

Bit 7	Bit 6	Bit 5	Bit 4	Bit 3	Bit 2	Bit 1	Bit 0
Sec7_Prot	Sec6_Prot	Sec5_Prot	Sec4_Prot	Sec3_Prot	Sec2_Prot	Sec1_Prot	Sec0_Prot

Sec<i>_Prot:

- 1: Primary Flash memory Sector <i> is write protected.
- 0: Primary Flash memory Sector <i> is not write protected.

6.12 Flash Boot Protection register

Table 20. Flash Boot Protection register

Bit 7	Bit 6	Bit 5	Bit 4	Bit 3	Bit 2	Bit 1	Bit 0
Security_Bit	not used	not used	not used	Sec3_Prot	Sec2_Prot	Sec1_Prot	Sec0_Prot

Sec<i></i>_Prot:

- 1: Secondary Flash memory Sector <i></i> is write protected.
- 0: Secondary Flash memory Sector <i></i> is not write protected.

Security_Bit:

- 0: Security bit in device has not been set.
- 1: Security bit in device has been set.

6.13 JTAG Enable register

Table 21. JTAG Enable register

Bit 7	Bit 6	Bit 5	Bit 4	Bit 3	Bit 2	Bit 1	Bit 0
not used	not used	not used	not used	not used	not used	not used	JTAG Enable

JTAGEnable:

- 1: JTAG Port is enabled.
- 0: JTAG Port is disabled.

6.14 Page register

This register configures the page input to PLD.

Default value is PGR7-PGR0=0.

Table 22. Page register

Bit 7	Bit 6	Bit 5	Bit 4	Bit 3	Bit 2	Bit 1	Bit 0
PGR 7	PGR 6	PGR 5	PGR 4	PGR 3	PGR 2	PGR 1	PGR 0

6.15 PMMR0 register

The bits of this register are cleared to zero following Power-up. Subsequent Reset ($\overline{\text{RESET}}$) pulses do not clear the registers.

Table 23. PMMR0 register

Bit 7	Bit 6	Bit 5	Bit 4	Bit 3	Bit 2	Bit 1	Bit 0
not used (set to '0')	not used (set to '0')	PLD MCells CLK	PLD Array CLK	PLD Turbo	not used (set to '0')	APD Enable	not used (set to '0')

APD Enable:

- 0: Automatic Power-down (APD) is disabled.
- 1: Automatic Power-down (APD) is enabled.

PLD Turbo:

- 0: PLD Turbo is on.
- 1: PLD Turbo is off, saving power.

PLD Array CLK:

- 0: CLKIN to the PLD AND array is connected. Every CLKIN change powers up the PLD when Turbo bit is off.
- 1: CLKIN to the PLD AND array is disconnected, saving power.

PLD MCells CLK:

- 0: CLKIN to the PLD macrocells is connected.
- 1: CLKIN to the PLD macrocells is disconnected, saving power.

6.16 PMMR2 register

Table 24. PMMR2 register

Bit 7	Bit 6	Bit 5	Bit 4	Bit 3	Bit 2	Bit 1	Bit 0
not used (set to '0')	PLD Array WRH	PLD Array ALE	PLD Array CNTL2	PLD Array CNTL1	PLD Array CNTL0	not used (set to '0')	PLD Array Addr

For bit 4, bit 3, bit 2: See [Table 34](#) for the signals that are blocked on pins CNTL0-CNTL2.

PLD Array Addr:

- 0: Address A7-A0 are connected to the PLD array.
- 1: Address A7-A0 are blocked from the PLD array, saving power.

Note: In XA mode, A3-A0 come from PF3-PF0, and A7-A4 come from ADIO7-ADIO4).

PLD Array CNTL2:

- 0: CNTL2 input to the PLD AND array is connected.
- 1: CNTL2 input to the PLD AND array is disconnected, saving power.

PLD Array CNTL1

- 0: CNTL1 input to the PLD AND array is connected.
- 1: CNTL1 input to the PLD AND array is disconnected, saving power.

PLD Array CNTL0

- 0: CNTL0 input to the PLD AND array is connected.
- 1: CNTL0 input to the PLD AND array is disconnected, saving power.

PLD Array ALE

- 0: ALE input to the PLD AND array is connected.
- 1: ALE input to the PLD AND array is disconnected, saving power.

PLD Array WRH

0: WRH/DBE input to the PLD AND array is connected.

1: WRH/DBE input to the PLD AND array is disconnected, saving power.

6.17 VM register

Table 25. VM register

Bit 7	Bit 6	Bit 5	Bit 4	Bit 3	Bit 2	Bit 1	Bit 0
Peripheral mode	not used (set to '0')	not used (set to '0')	FL_data	Boot_data	FL_code	Boot_code	SR_code

On reset, bit1-Bit4 are loaded to configurations that are selected by the user in PSDsoft Express. bit0 and bit7 are always cleared on reset. bit0-Bit4 are active only when the device is configured in Philips 80C51XA mode.

SR_code

0 = $\overline{\text{PSEN}}$ cannot access SRAM in 80C51XA modes.

1 = $\overline{\text{PSEN}}$ can access SRAM in 80C51XA modes.

Boot_code

0 = $\overline{\text{PSEN}}$ cannot access Secondary NVM in 80C51XA modes.

1 = $\overline{\text{PSEN}}$ can access Secondary NVM in 80C51XA modes.

FL_code

0 = $\overline{\text{PSEN}}$ cannot access Primary Flash memory in 80C51XA modes.

1 = $\overline{\text{PSEN}}$ can access Primary Flash memory in 80C51XA modes.

Boot_data

0 = $\overline{\text{RD}}$ cannot access Secondary NVM in 80C51XA modes.

1 = $\overline{\text{RD}}$ can access Secondary NVM in 80C51XA modes.

FL_data

0 = $\overline{\text{RD}}$ cannot access Primary Flash memory in 80C51XA modes.

1 = $\overline{\text{RD}}$ can access Primary Flash memory in 80C51XA modes.

Peripheral mode

0 = Peripheral mode of Port F is disabled.

1 = Peripheral mode of Port F is enabled.

6.18 Memory_ID0 registers

Table 26. Memory_ID0 register

Bit 7	Bit 6	Bit 5	Bit 4	Bit 3	Bit 2	Bit 1	Bit 0
S_size 3	S_size 2	S_size 1	S_size 0	F_size 3	F_size 2	F_size 1	F_size 0

F_size[3:0]

- 0h = There is no Primary Flash memory
- 1h = Primary Flash memory size is 256 Kbit
- 2h = Primary Flash memory size is 512 Kbit
- 3h = Primary Flash memory size is 1 Mbit
- 4h = Primary Flash memory size is 2 Mbit
- 5h = Primary Flash memory size is 4 Mbit
- 6h = Primary Flash memory size is 8 Mbit

S_size[3:0]

- 0h = There is no SRAM
- 1h = SRAM size is 16 Kbit
- 2h = SRAM size is 32 Kbit
- 3h = SRAM size is 64 Kbit
- 4h = SRAM size is 128 Kbit
- 5h = SRAM size is 256 Kbit

6.19 Memory_ID1 register

Table 27. Memory_ID1 register

Bit 7	Bit 6	Bit 5	Bit 4	Bit 3	Bit 2	Bit 1	Bit 0
not used (set to '0')	not used (set to '0')	B_type 1	B_type 0	B_size 3	B_size 2	B_size 1	B_size 0

B_size[3:0]

- 0h = There is no Secondary NVM
- 1h = Secondary NVM size is 128 Kbit
- 2h = Secondary NVM size is 256 Kbit
- 3h = Secondary NVM size is 512 Kbit

B_type[1:0]

- 0h = Secondary NVM is Flash memory
- 1h = Secondary NVM is EEPROM

7 Detailed operation

As shown in [Figure 3](#), the PSD consists of six major types of functional blocks:

- Memory blocks
- PLD blocks
- MCU bus Interface
- I/O ports
- Power management unit (PMU)
- JTAG-ISP interface

The functions of each block are described in the following sections. Many of the blocks perform multiple functions, and are user configurable.

7.1 Memory blocks

The PSD has the following memory blocks:

- Primary Flash memory
- Secondary Flash memory
- SRAM

The Memory Select signals for these blocks originate from the Decode PLD (DPLD) and are user-defined in PSDsoft Express.

[Table 28](#) summarizes the sizes and organisations of the memory blocks.

Table 28. Memory block size and organization

Sector number	Primary Flash Memory		Secondary Flash Memory		SRAM	
	Sector size (x16, Kbytes)	Sector Select signal	Sector size (x16, Kbytes)	Sector Select signal	SRAM size (x16, Kbytes)	SRAM Select signal
0	32	FS0	4	CSBOOT0	4	RS0
1	32	FS1	4	CSBOOT1		
2	32	FS2	4	CSBOOT2		
3	32	FS3	4	CSBOOT3		
4	32	FS4				
5	32	FS5				
6	32	FS6				
7	32	FS7				
Total	512 Kbytes	8 sectors	32 Kbytes	4 sectors	8 Kbytes	

7.2 Primary Flash memory and Secondary Flash memory description

The primary Flash memory is divided evenly into 8 sectors. The secondary Flash memory is divided evenly into 4 sectors. Each sector of either memory block can be separately protected from Program and Erase cycles.

Flash memory may be erased on a sector-by-sector basis, and programmed word-by-word. Flash sector erasure may be suspended while data is read from other sectors of the block and then resumed after reading.

During a Program or Erase cycle in Flash memory, the status can be output on the Ready/Busy pin (PE4). This pin is set up using PSDsoft Express.

7.2.1 Memory block Select signals

The DPLD generates the Select signals for all the internal memory blocks (see [Section 16: PLDS](#)). Each of the sectors of the primary Flash memory has a Select signal (FS0-FS7) which can contain up to three product terms. Each of the sectors of the secondary Flash memory has a Select signal (CSBOOT0-CSBOOT3) which can contain up to three product terms. Having three product terms for each Select signal allows a given sector to be mapped in different areas of system memory. When using a MCU with separate Program and Data space (80C51XA), these flexible Select signals allow dynamic re-mapping of sectors from one memory space to the other before and after IAP. The SRAM block has a single Select signal (RS0).

7.2.2 Ready/Busy (PE4)

This signal can be used to output the Ready/Busy status of the PSD. The output is a '0' (Busy) when a Flash memory block is being written to, or when a Flash memory block is being erased. The output is a '1' (Ready) when no WRITE or Erase cycle is in progress.

7.3 Memory operation

The primary Flash memory and secondary Flash memory are addressed through the MCU Bus Interface. The MCU can access these memories in one of two ways:

- The MCU can execute a typical bus WRITE or READ *operation* just as it would if accessing a RAM or ROM device using standard bus cycles.
- The MCU can execute a specific instruction that consists of several WRITE and READ operations. This involves writing specific data patterns to special addresses within the Flash memory to invoke an embedded algorithm. These instructions are summarized in [Table 29](#).

Typically, the MCU can read Flash memory using READ operations, just as it would read a ROM device. However, Flash memory can only be erased and programmed using specific instructions. For example, the MCU cannot write a single byte directly to Flash memory as one would write a byte to RAM. To program a word into Flash memory, the MCU must execute a Program instruction, then test the status of the Programming event. This status test is achieved by a READ operation or polling Ready/Busy (PE4).

Flash memory can also be read by using special instructions to retrieve particular Flash device information (sector protect status and ID).

Table 29. Instructions⁽¹⁾⁽²⁾⁽³⁾

Instruction ⁽⁴⁾	FS0-FS7 or CSBOOT0-CSBOOT3 ⁽⁵⁾	Cycle 1	Cycle 2	Cycle 3	Cycle 4	Cycle 5	Cycle 6	Cycle 7
READ ⁽⁶⁾	1	"Read" RD @ RA						
Read Main Flash ID ⁽⁷⁾	1	AAh@ XAAAh	55h@ X554h	90h@ XAAAh	Read ID @ XX02h			
Read Sector Protection ⁽⁷⁾⁽⁸⁾ (9)	1	AAh@ XAAAh	55h@ X554h	90h@ XAAAh	Read 00h or 01h @ XX04h			
Program a Flash Word ⁽⁹⁾	1	AAh@ XAAAh	55h@ X554h	A0h@ XAAAh	PD@ PA			
Flash Sector Erase ⁽¹⁰⁾⁽⁹⁾	1	AAh@ XAAAh	55h@ X554h	80h@ XAAAh	AAh@ XAAAh	55h@ X554h	30h@ SA	30h ⁽¹⁰⁾ @ next SA
Flash Bulk Erase ⁽⁹⁾	1	AAh@ XAAAh	55h@ X554h	80h@ XAAAh	AAh@ XAAAh	55h@ X554h	10h@ XAAAh	
Suspend Sector Erase ⁽¹¹⁾	1	B0h@ XXXXh						
Resume Sector Erase ⁽¹²⁾	1	30h@ XXXXh						
Reset ⁽⁷⁾	1	F0h@ XXXXh						
Unlock Bypass	1	AAh@ XAAAh	55h@ X554h	20h@ XAAAh				
Unlock Bypass Program ⁽¹³⁾	1	A0h@ XXXXh	PD@ PA					
Unlock Bypass Reset ⁽¹⁴⁾	1	90h@ XXXXh	00h@ XXXXh					

1. All bus cycles are WRITE bus cycles, except the ones with the "Read" label
2. All values are in hexadecimal:
X = Don't Care. Addresses of the form XXXXh, in this table, must be even addresses, RA = Address of the memory location to be read
RD = Data read from location RA during the READ cycle
PA = Address of the memory location to be programmed. Addresses are latched on the falling edge of Write Strobe (\overline{WR} , CNTL0). PA is an even address for PSD in word programming mode.
PD = Data word to be programmed at location PA. Data is latched on the rising edge of Write Strobe (\overline{WR} , CNTL0)
SA = Address of the sector to be erased or verified. The Sector Select (FS0-FS7 or CSBOOT0-CSBOOT3) of the sector to be erased, or verified, must be Active (High).
3. Only address bits A11-A0 are used in instruction decoding.
4. All WRITE bus cycles in an instruction are byte WRITE to an even address (XA4Ah or X554h). A Flash memory Program bus cycle writes a word to an even address.
5. Sector Select (FS0 to FS7 or CSBOOT0 to CSBOOT3) signals are active high, and are defined in PSDsoft Express.
6. No Unlock or instruction cycles are required when the device is in the READ mode.
7. The Reset instruction is required to return to the READ mode after reading the Flash ID, or after reading the Sector Protection Status, or if the Error Flag bit (DQ5/DQ13) goes high.
8. The data is 00h for an unprotected sector, and 01h for a protected sector. In the fourth cycle, the Sector Select is active, and (A1,A0)=(1,0)

9. The MCU cannot invoke these instructions while executing code from the same Flash memory as that for which the instruction is intended. The MCU must fetch, for example, the code from the secondary Flash memory when reading the Sector Protection Status of the primary Flash memory.
10. Additional sectors to be erased must be written at the end of the Sector Erase instruction within 80 μ s.
11. The system may perform READ and Program cycles in non-erasing sectors, read the Flash ID or read the Sector Protection Status when in the Suspend Sector Erase mode. The Suspend Sector Erase instruction is valid only during a Sector Erase cycle.
12. The Resume Sector Erase instruction is valid only during the Suspend Sector Erase mode.
13. The Unlock Bypass instruction is required prior to the Unlock Bypass Program instruction.
14. The Unlock Bypass Reset Flash instruction is required to return to reading memory data when the device is in the Unlock Bypass mode.

8 Instructions

An instruction consists of a sequence of specific operations. Each received byte is sequentially decoded by the PSD and not executed as a standard WRITE operation. The instruction is executed when the correct number of bytes are properly received and the time between two consecutive bytes is shorter than the timeout period. Some instructions are structured to include READ operations after the initial WRITE operations.

The instruction must be followed exactly. Any invalid combination of instruction bytes or timeout between two consecutive bytes while addressing Flash memory resets the device logic into READ mode (Flash memory is read like a ROM device).

The PSD supports the instructions summarized in [Table 29](#):

- Erase memory by chip or sector
- Suspend or resume sector erase
- Program a Word
- Reset to READ mode
- Read primary Flash Identifier value
- Read Sector Protection Status
- Bypass

These instructions are detailed in [Table 29](#). For efficient decoding of the instructions, the first two bytes of an instruction are the coded cycles and are followed by an instruction byte or confirmation byte. The coded cycles consist of writing the data AAh to address XAAAh during the first cycle and data 55h to address X554h during the second cycle (unless the Bypass instruction feature is used, as described later). Address signals A15-A12 are Don't Care during the instruction WRITE cycles. However, the appropriate Sector Select signal (FS0-FS7, or CSBOOT0-CSBOOT3) must be selected.

The primary and secondary Flash memories have the same instruction set (except for Read Primary Flash Identifier). The Sector Select signals determine which Flash memory is to receive and execute the instruction. The primary Flash memory is selected if any one of its Sector Select signals (FS0-FS7) is high, and the secondary Flash memory is selected if any one of its Sector Select signals (CSBOOT0-CSBOOT3) is high.

8.1 Power-up condition

The PSD internal logic is reset upon Power-up to the READ mode. Sector Select (FS0-FS7 and CSBOOT0-CSBOOT3) must be held low, and Write Strobe ($\overline{\text{WR/WRL}}$, CNTL0) high, during Power-up for maximum security of the data contents and to remove the possibility of data being written on the first edge of Write Strobe ($\overline{\text{WR/WRL}}$, CNTL0). Any WRITE cycle initiation is locked when V_{CC} is below V_{LKO} .

8.2 Reading Flash memory

Under typical conditions, the MCU may read the primary Flash memory, or secondary Flash memory, using READ operations just as it would a ROM or RAM device. Alternately, the MCU may use READ operations to obtain status information about a Program or Erase cycle that is currently in progress. Lastly, the MCU may use instructions to read special data from these memory blocks. The following sections describe these READ functions.

8.3 Read memory contents

Primary Flash memory and secondary Flash memory are placed in the READ mode after Power-up, chip reset, or a Reset Flash instruction (see [Table 29](#)). The MCU can read the memory contents of the primary Flash memory, or the secondary Flash memory by using READ operations any time the READ operation is not part of an instruction.

8.4 Read Primary Flash identifier

The primary Flash memory identifier is read with an instruction composed of 4 operations: 3 specific WRITE operations and a READ operation (see [Table 29](#)). The identifier for the primary Flash memory is E8h. The secondary Flash memory does not support this instruction.

8.5 Read Memory Sector Protection status

The Flash memory Sector Protection Status is read with an instruction composed of four operations: three specific WRITE operations and a READ operation (see [Table 29](#)). The READ operation produces 01h if the Flash memory sector is protected, or 00h if the sector is not protected.

The sector protection status for all NVM blocks (primary Flash memory, or secondary Flash memory) can be read by the MCU accessing the Flash Protection and Flash Boot Protection registers in PSD I/O space. See [Section 11.1: Flash Memory Sector Protect](#), for register definitions.

8.6 Reading the Erase/Program status bits

The PSD provides several status bits to be used by the MCU to confirm the completion of an Erase or Program cycle of Flash memory. These status bits minimize the time that the MCU spends performing these tasks and are defined in [Table 30](#). The status byte resides in an even location, and can be read as many times as needed. Also note that DQ15-DQ8 is an even byte for Motorola MCUs with a 16-bit data bus.

For Flash memory, the MCU can perform a READ operation to obtain these status bits while an Erase or Program instruction is being executed by the embedded algorithm. See [Section 9: Programming Flash memory](#), for details.

Table 30. Status bits

DQ7	DQ6	DQ5	DQ4	DQ3	DQ2	DQ1	DQ0
Data Polling	Toggle Flag	Error Flag	X	Erase timeout	X	X	X

Table 31. Status bits for Motorola⁽¹⁾⁽²⁾⁽³⁾

DQ15	DQ14	DQ13	DQ12	DQ11	DQ10	DQ9	DQ8
Data Polling	Toggle Flag	Error Flag	X	Erase timeout	X	X	X

1. X = Not guaranteed value, can be read either 1 or 0.
2. DQ15-DQ0 represent the Data Bus bits, D15-D0.
3. FS0-FS7/CSBOOT0-CSBOOT3 are active high.

8.7 Data Polling (DQ7) - DQ15 for Motorola

When erasing or programming in Flash memory, the Data Polling bit (DQ7/DQ15) outputs the complement of the bit being entered for programming/writing on the DQ7/DQ15 bit. Once the Program instruction or the WRITE operation is completed, the true logic value is read on the Data Polling bit (DQ7/DQ15, in a READ operation).

- Data Polling is effective after the fourth WRITE pulse (for a Program instruction) or after the sixth WRITE pulse (for an Erase instruction). It must be performed at the address being programmed or at an address within the Flash memory sector being erased.
- During an Erase cycle, the Data Polling bit (DQ7/DQ15) outputs a '0.' After completion of the cycle, the Data Polling bit (DQ7/DQ15) outputs the last bit programmed (it is a '1' after erasing).
- If the location to be programmed is in a protected Flash memory sector, the instruction is ignored.
- If all the Flash memory sectors to be erased are protected, the Data Polling bit (DQ7/DQ15) is reset to '0' for about 100 μ s, and then returns to the value from the previously addressed location. No erasure is performed.

8.8 Toggle flag (DQ6) - DQ14 for Motorola

The PSD offers another way for determining when the Flash memory Program cycle is completed. During the internal WRITE operation and when either FS0-FS7 or CSBOOT0-CSBOOT3 is true, the Toggle Flag bit (DQ6/DQ14) bit toggles from 0 to '1' and 1 to '0' on subsequent attempts to read any word of the memory.

When the internal cycle is complete, the toggling stops and the data read on the Data Bus D0-D7 is the value from the addressed memory location. The device is now accessible for a

new READ or WRITE operation. The cycle is finished when two successive READs yield the same output data.

- The Toggle Flag bit (DQ6/DQ14) is effective after the fourth WRITE pulse (for a Program instruction) or after the sixth WRITE pulse (for an Erase instruction).
- If the location to be programmed belongs to a protected Flash memory sector, the instruction is ignored.
- If all the Flash memory sectors selected for erasure are protected, the Toggle Flag bit (DQ6/DQ14) toggles to '0' for about 100 μ s and then returns to the value from the previously addressed location.

8.9 Error flag (DQ5) - DQ13 for Motorola

During a normal Program or Erase cycle, the Error Flag bit (DQ5/DQ13) is reset to '0.' This bit is set to '1' when there is a failure during a Flash memory Program, Sector Erase, or Bulk Erase cycle.

In the case of Flash memory programming, the Error Flag bit (DQ5/DQ13) indicates the attempt to program a Flash memory bit, or bits, from the programmed state, 0, to the erased state, 1, which is not a valid operation. The Error Flag bit (DQ5/DQ13) may also indicate a timeout condition while attempting to program a word.

In case of an error in a Flash memory Sector Erase or Word Program cycle, the Flash memory sector in which the error occurred or to which the programmed location belongs must no longer be used. Other Flash memory sectors may still be used. The Error Flag bit (DQ5/DQ13) is reset after a Reset instruction. A Reset instruction is required after detecting an error on the Error Flag bit (DQ5/DQ13).

8.10 Erase timeout flag (DQ3) - DQ11 for Motorola

The Erase timeout Flag bit (DQ3/DQ11) reflects the timeout period allowed between two consecutive Sector Erase instructions. The Erase timeout Flag bit (DQ3/DQ11) is reset to '0' after a Sector Erase cycle for a period of 100 μ s + 20% unless an additional Sector Erase instruction is decoded. After this period, or when the additional Sector Erase instruction is decoded, the Erase timeout flag (DQ3/DQ11) bit is set to 1.

9 Programming Flash memory

Flash memory must be erased prior to being programmed. The MCU may erase Flash memory all at once or by-sector. Although erasing Flash memory occurs on a sector or device basis, programming Flash memory occurs on a word basis.

The primary and secondary Flash memories require the MCU to send an instruction to program a word or to erase sectors (see [Table 29](#)).

Once the MCU issues a Flash memory Program or Erase instruction, it must check the status bits for completion. The embedded algorithms that are invoked inside the PSD support several means to provide status to the MCU. Status may be checked using any of three methods: Data Polling, Data Toggle, or Ready/Busy (PE4) signal.

9.1 Data polling

Polling on the Data Polling bit (DQ7/DQ15) is a method of checking whether a Program or Erase cycle is in progress or has completed. [Figure 5](#) shows the Data Polling algorithm.

When the MCU issues a Program instruction, the embedded algorithm within the PSD begins. The MCU then reads the location of the word to be programmed in Flash memory to check the status. The Data Polling bit (DQ7/DQ15) becomes the complement of the corresponding bit of the original data word to be programmed. The MCU continues to poll this location, comparing data and monitoring the Error Flag bit (DQ5/DQ13). When the Data Polling bit (DQ7/DQ15) matches the corresponding bit of the original data, and the Error Flag bit (DQ5/DQ13) remains 0, the embedded algorithm is complete. If the Error Flag bit (DQ5/DQ13) is 1, the MCU should test the Data Polling bit (DQ7/DQ15) again since the Data Polling bit (DQ7/DQ15) may have changed simultaneously with the Error Flag bit (DQ5/DQ13, see [Figure 5](#)).

The Error Flag bit (DQ5/DQ13) is set if either an internal timeout occurred while the embedded algorithm attempted to program the location or if the MCU attempted to program a '1' to a bit that was not erased (not erased is logic 0).

It is suggested (as with all Flash memories) to read the location again after the embedded programming algorithm has completed, to compare the word that was written to the Flash memory with the word that was intended to be written.

When using the Data Polling method during an Erase cycle, [Figure 5](#) still applies. However, the Data Polling bit (DQ7/DQ15) is 0 until the Erase cycle is complete. A '1' on the Error Flag bit (DQ5/DQ13) indicates a timeout condition on the Erase cycle, a '0' indicates no error. The MCU can read any even location within the sector being erased to get the Data Polling bit (DQ7/DQ15) and the Error Flag bit (DQ5/DQ13).

PSDsoft Express generates ANSI C code functions that implement these Data Polling algorithms.

Figure 5. Data polling flowchart

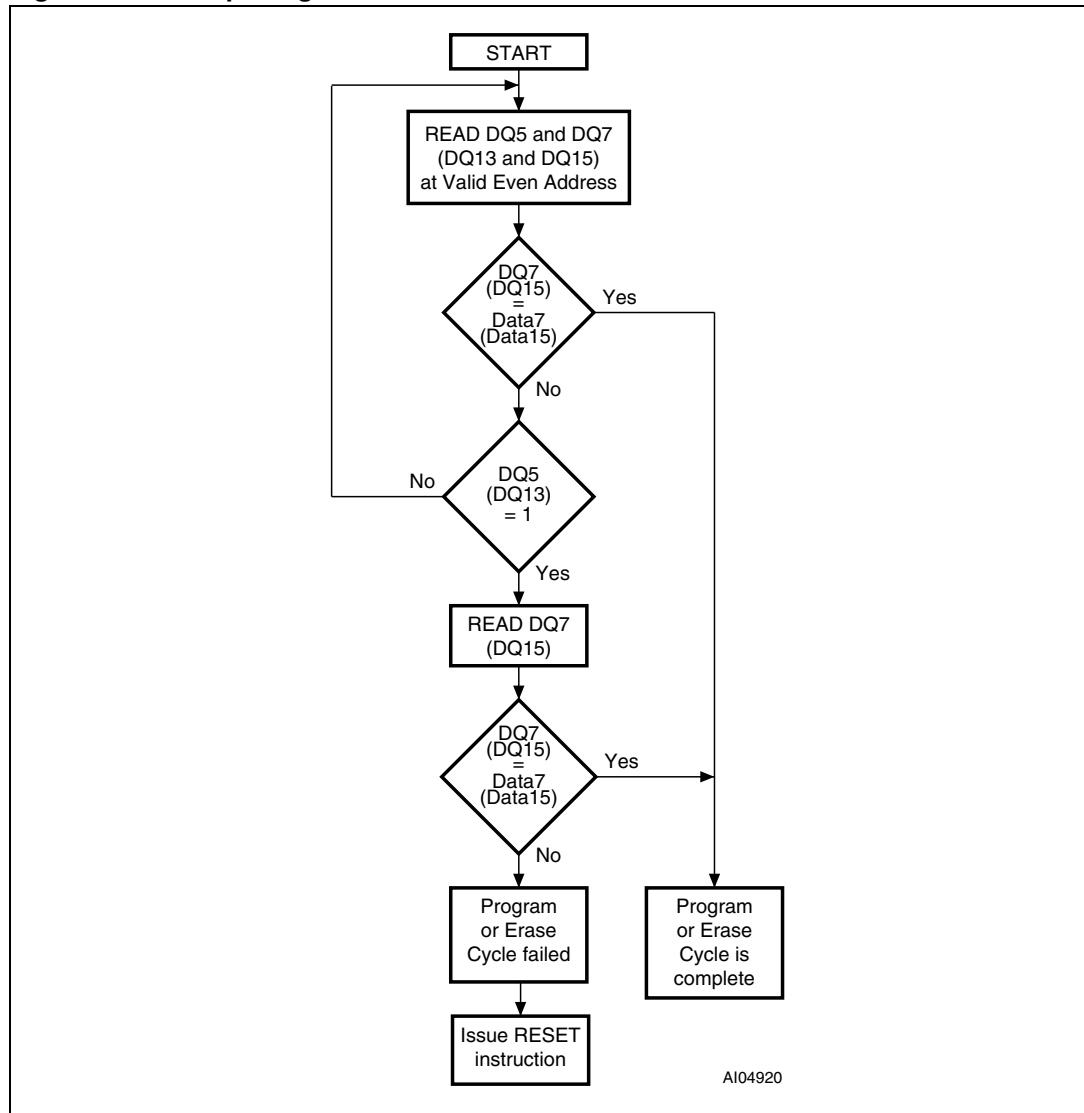

9.2 Data toggle

Checking the Toggle Flag bit (DQ6/DQ14) is another method of determining whether a Program or Erase cycle is in progress or has completed. [Figure 6](#) shows the Data Toggle algorithm.

When the MCU issues a Program instruction, the embedded algorithm within the PSD begins. The MCU then reads the location to be programmed in Flash memory to check the status. The Toggle Flag bit (DQ6/DQ14) toggles each time the MCU reads this location until the embedded algorithm is complete. The MCU continues to read this location, checking the Toggle Flag bit (DQ6/DQ14) and monitoring the Error Flag bit (DQ5/DQ13). When the Toggle Flag bit (DQ6/DQ14) stops toggling (two consecutive READs yield the same value), and the Error Flag bit (DQ5/DQ13) remains 0, the embedded algorithm is complete. If the Error Flag bit (DQ5/DQ13) is 1, the MCU should test the Toggle Flag bit (DQ6/DQ14) again,

since the Toggle Flag bit (DQ6/DQ14) may have changed simultaneously with the Error Flag bit (DQ5/DQ13, see [Figure 6](#)).

The Error Flag bit (DQ5/DQ13) is set if either an internal timeout occurred while the embedded algorithm attempted to program, or if the MCU attempted to program a '1' to a bit that was not erased (not erased is logic 0).

It is suggested (as with all Flash memories) to read the location again after the embedded programming algorithm has completed, to compare the word that was written to Flash memory with the word that was intended to be written.

When using the Data Toggle method after an Erase cycle, [Figure 6](#) still applies. the Toggle Flag bit (DQ6/DQ14) toggles until the Erase cycle is complete. A '1' on the Error Flag bit (DQ5/DQ13) indicates a timeout condition on the Erase cycle, a '0' indicates no error. The MCU can read any even location within the sector being erased to get the Toggle Flag bit (DQ6/DQ14) and the Error Flag bit (DQ5/DQ13).

PSDsoft Express generates ANSI C code functions which implement these Data Toggling algorithms.

9.3 Unlock Bypass

The Unlock Bypass instruction allows the system to program words to the Flash memories faster than using the standard Program instruction. The Unlock Bypass mode is entered by first initiating two Unlock cycles. This is followed by a third WRITE cycle containing the Unlock Bypass command, 20h (as shown in [Table 29](#)). The Flash memory then enters the Unlock Bypass mode.

A two-cycle Unlock Bypass Program instruction is all that is required to program in this mode. The first cycle in this instruction contains the Unlock Bypass Program command, A0h. The second cycle contains the program address and data. Additional data is programmed in the same manner. This mode dispense with the initial two Unlock cycles required in the standard Program instruction, resulting in faster total programming time.

During the unlock bypass mode, only the Unlock Bypass Program and Unlock Bypass Reset instructions are valid.

To exit the Unlock Bypass mode, the system must issue the two-cycle Unlock Bypass Reset instruction. The first cycle must contain the data 90h; the second cycle the data 00h. Addresses are Don't Care for both cycles. The Flash memory then returns to READ mode.

Figure 6. Data toggle flowchart

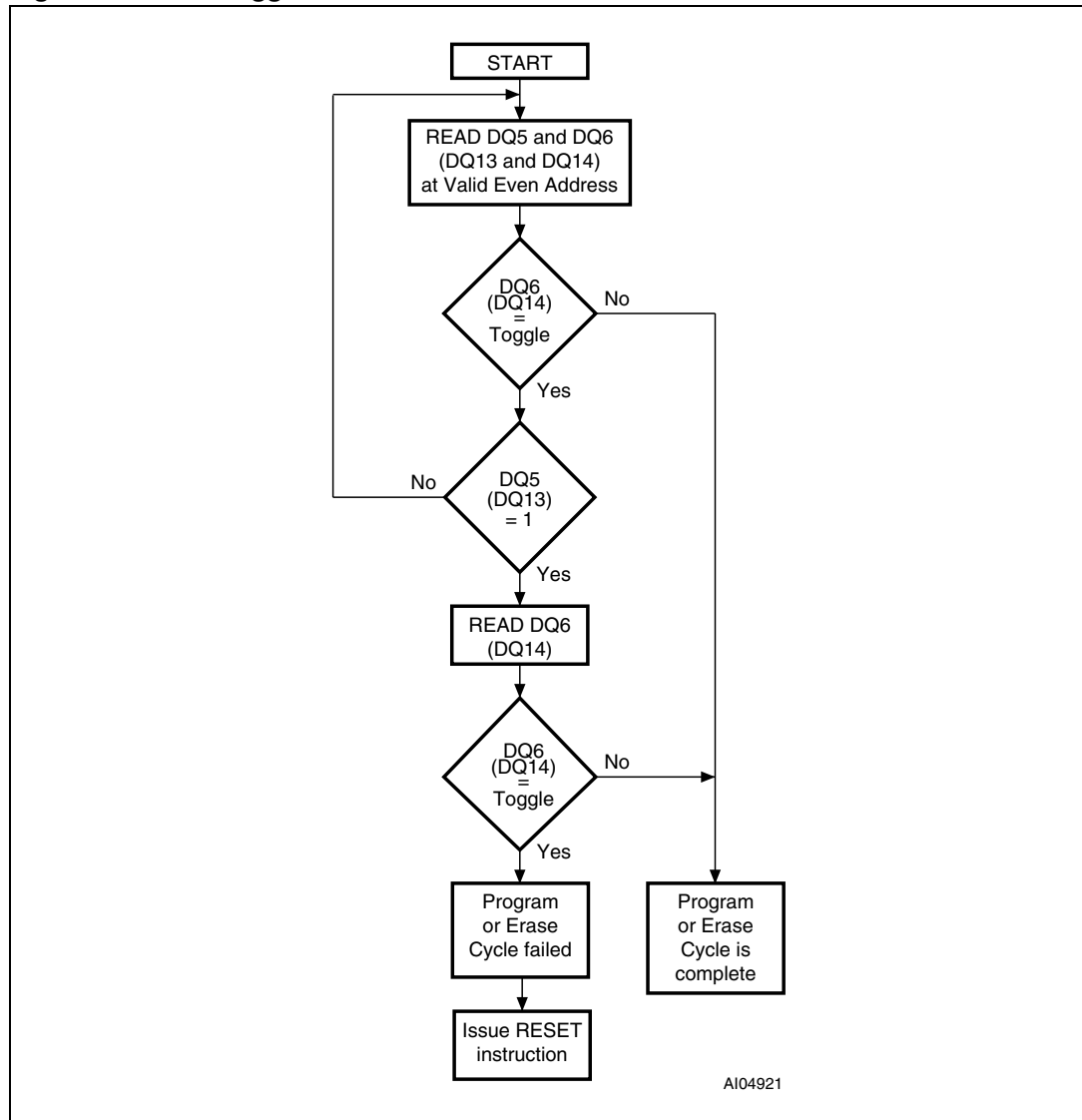

10 Erasing Flash memory

10.1 Flash Bulk Erase

The Flash Bulk Erase instruction uses six WRITE operations followed by a READ operation of the status register, as described in [Table 29](#). If any byte of the Bulk Erase instruction is wrong, the Bulk Erase instruction aborts and the device is reset to the Read Memory mode.

During a Bulk Erase, the memory status may be checked by reading the Error Flag bit (DQ5/DQ13), the Toggle Flag bit (DQ6/DQ14), and the Data Polling bit (DQ7/DQ15), as detailed in [Section 9: Programming Flash memory](#). The Error Flag bit (DQ5/DQ13) returns a '1' if there has been an Erase Failure (maximum number of Erase cycles have been executed).

It is not necessary to program the memory with 00h because the PSD automatically does this before erasing to 0FFh.

During execution of the Bulk Erase instruction, the Flash memory does not accept any instructions.

Flash Sector Erase

The Sector Erase instruction uses six WRITE operations, as described in [Table 29](#). Additional Flash Sector Erase confirm commands and Flash memory sector addresses can be written subsequently to erase other Flash memory sectors in parallel, without further coded cycles, if the additional commands are transmitted in a shorter time than the timeout period of about 100 μ s. The input of a new Sector Erase command restarts the timeout period.

The status of the internal timer can be monitored through the level of the Erase timeout Flag bit (DQ3/DQ11). If the Erase timeout Flag bit (DQ3/DQ11) is 0, the Sector Erase instruction has been received and the timeout period is counting. If the Erase timeout Flag bit (DQ3/DQ11) is 1, the timeout period has expired and the PSD is busy erasing the Flash memory sector(s). Before and during Erase timeout, any instruction other than Suspend Sector Erase and Resume Sector Erase, abort the cycle that is currently in progress, and reset the device to READ mode. It is not necessary to program the Flash memory sector with 00h as the PSD does this automatically before erasing.

During a Sector Erase, the memory status may be checked by reading the Error Flag bit (DQ5/DQ13), the Toggle Flag bit (DQ6/DQ14), and the Data Polling bit (DQ7/DQ15), as detailed in [Section 9: Programming Flash memory](#).

During execution of the Erase cycle, the Flash memory accepts only Reset and Suspend Sector Erase instructions. Erasure of one Flash memory sector may be suspended, in order to read data from another Flash memory sector, and then resumed.

10.2 Suspend Sector Erase

When a Sector Erase cycle is in progress, the Suspend Sector Erase instruction can be used to suspend the cycle by writing 0B0h to any even address when an appropriate Sector Select (FS0-FS7 or CSBOOT0-CSBOOT3) is high. (See [Table 29](#)). This allows reading of data from another Flash memory sector after the Erase cycle has been suspended.

Suspend Sector Erase is accepted only during the Flash Sector Erase instruction execution and defaults to READ mode. A Suspend Sector Erase instruction executed during an Erase timeout period, in addition to suspending the Erase cycle, terminates the time out period.

The Toggle Flag bit (DQ6/DQ14) stops toggling when the PSD internal logic is suspended. The status of this bit must be monitored at an address within the Flash memory sector being erased. The Toggle Flag bit (DQ6/DQ14) stops toggling between 0.1µs and 15 µs after the Suspend Sector Erase instruction has been executed. The PSD is then automatically set to READ mode.

If an Suspend Sector Erase instruction was executed, the following rules apply:

- Attempting to read from a Flash memory sector that was being erased outputs invalid data.
- Reading from a Flash memory sector that was *not* being erased is valid.
- The Flash memory *cannot* be programmed, and only responds to Resume Sector Erase and Reset instructions (READ is an operation and is allowed).
- If a Reset instruction is received, data in the Flash memory sector that was being erased is invalid.

10.3 Resume Sector Erase

If a Suspend Sector Erase instruction was previously executed, the Erase cycle may be resumed with this instruction. The Resume Sector Erase instruction consists of writing 030h to any even address while an appropriate Sector Select (FS0-FS7 or CSBOOT0-CSBOOT3) is high. (See [Table 29](#).)

11 Specific features

11.1 Flash Memory Sector Protect

Each sector of Primary or Secondary Flash memory can be separately protected against Program and Erase cycles. Sector Protection provides additional data security because it disables all Program or Erase cycles. This mode can be activated (or deactivated) through the JTAG-ISP Port or a device programmer.

Sector protection can be selected for each sector using the PSDsoft Express program. This automatically protects selected sectors when the device is programmed through the JTAG Port or a device programmer. Flash memory sectors can be unprotected to allow updating of their contents using the JTAG Port or a device programmer. The MCU can read (but cannot change) the sector protection bits.

Any attempt to program or erase a protected Flash memory sector is ignored by the device. The Verify operation results in a READ of the protected data. This allows a guarantee of the retention of the Protection status.

The sector protection status can be read by the MCU through the Flash memory protection and Secondary Flash memory protection registers (in the CSIOP block) or use the Read Sector Protection instruction. See [Table 19](#) to [Table 20](#).

11.2 Reset

The Reset instruction consists of one WRITE cycle (see [Table 29](#)). It can also be optionally preceded by the standard two WRITE decoding cycles (writing AAh to AAAh, and 55h to 554h).

The Reset instruction must be executed after:

- Reading the Flash Protection Status or Flash ID
- An Error condition has occurred (and the device has set the Error Flag bit (DQ5/DQ13) to '1') during a Flash memory Program or Erase cycle.

The Reset instruction immediately puts the Flash memory back into normal READ mode. However, if there is an error condition (with the Error Flag bit (DQ5/DQ13) set to '1') the Flash memory will return to the READ mode in 25 μ s after the Reset instruction is issued.

The Reset instruction is ignored when it is issued during a Program or Bulk Erase cycle of the Flash memory. The Reset instruction aborts any on-going Sector Erase cycle, and returns the Flash memory to the normal READ mode in 25 μ s.

11.3 Reset ($\overline{\text{RESET}}$) pin

A pulse on the Reset ($\overline{\text{RESET}}$) pin aborts any cycle that is in progress, and resets the Flash memory to the READ mode. When the reset occurs during a Program or Erase cycle, the Flash memory takes up to 25 μ s to return to the READ mode. It is recommended that the Reset ($\overline{\text{RESET}}$) pulse (except for Power-on Reset, as described in [Section 22.1](#)) be at least 25 μ s so that the Flash memory is always ready for the MCU to fetch the bootstrap instructions after the Reset cycle is complete.

12 SRAM

The SRAM is enabled when SRAM Select (RS0) from the DPLD is high. SRAM Select (RS0) can contain up to three product terms, allowing flexible memory mapping.

SRAM Select (RS0) is configured using PSDsoft Express.

13 Memory Select signals

The Primary Flash Memory Sector Select (FS0-FS7), Secondary Flash Memory Sector Select (CSBOOT0-CSBOOT3) and SRAM Select (RS0) signals are all outputs of the DPLD. They are defined using PSDsoft Express. The following rules apply to the equations for these signals:

- Primary Flash memory and secondary Flash memory Sector Select signals must *not* be larger than the physical sector size.
- Any primary Flash memory sector must *not* be mapped in the same memory space as another Flash memory sector.
- A secondary Flash memory sector must *not* be mapped in the same memory space as another secondary Flash memory sector.
- SRAM, I/O, and Peripheral I/O spaces must *not* overlap.
- A secondary Flash memory sector *may* overlap a primary Flash memory sector. In case of overlap, priority is given to the secondary Flash memory sector.
- SRAM, I/O, and Peripheral I/O spaces *may* overlap any other memory sector. Priority is given to the SRAM, I/O, or Peripheral I/O.

13.1 Example

FS0 is valid when the address is in the range of 8000h to BFFFh, CSBOOT0 is valid from 8000h to 9FFFh, and RS0 is valid from 8000h to 87FFh. Any address in the range of RS0 always accesses the SRAM. Any address in the range of CSBOOT0 greater than 87FFh (and less than 9FFFh) automatically addresses secondary Flash memory segment 0. Any address greater than 9FFFh accesses the primary Flash memory segment 0. You can see that half of the primary Flash memory segment 0 and one-fourth of secondary Flash memory segment 0 cannot be accessed in this example. Also note that an equation that defined FS1 to anywhere in the range of 8000h to BFFFh would *not* be valid.

Figure 7 shows the priority levels for all memory components. Any component on a higher level can overlap and has priority over any component on a lower level. Components on the same level must *not* overlap. level 1 has the highest priority and level 3 has the lowest.

13.2 Memory Select configuration for MCUs with separate Program and Data spaces

The 80C51XA and compatible family of MCUs, can be configured to have separate address spaces for Program memory (selected using Program Select Enable (PSEN, CNTL2)) and Data memory (selected using Read Strobe (RD, CNTL1)). Any of the memories within the PSD can reside in either space or both spaces. This is controlled through manipulation of the VM register that resides in the CSIOP space.

The VM register is set using PSDsoft Express to have an initial value. It can subsequently be changed by the MCU so that memory mapping can be changed on-the-fly.

For example, you may wish to have SRAM and primary Flash memory in the Data space at Boot-up, and secondary Flash memory in the Program space at Boot-up, and later swap the secondary Flash memory and primary Flash memory. This is easily done with the VM

register by using PSDsoft Express to configure it for Boot-up and having the MCU change it when desired.

[Table 25](#) describes the VM register.

Figure 7. Priority level of memory and I/O components

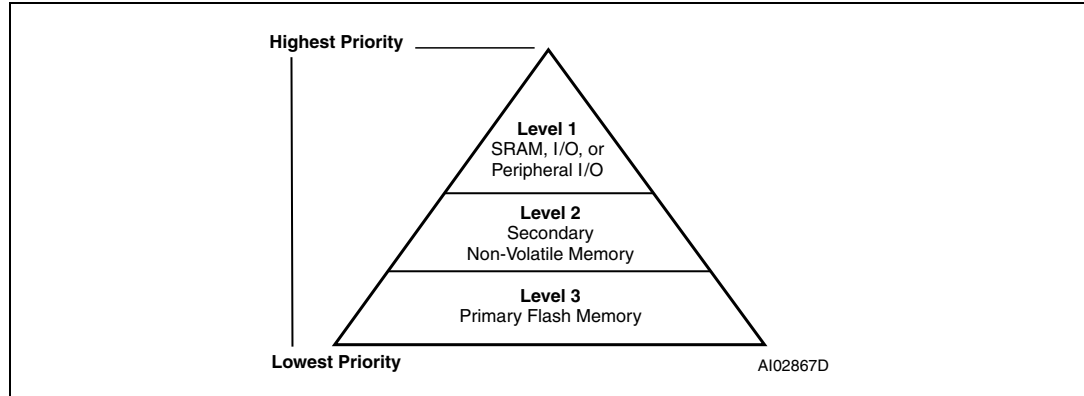

13.3 Separate space modes

Program space is separated from Data space. For example, Program Select Enable ($\overline{\text{PSEN}}$, CNTL2) is used to access the program code from the primary Flash memory, while Read Strobe ($\overline{\text{RD}}$, CNTL1) is used to access data from the secondary Flash memory, SRAM and I/O Port blocks. This configuration requires the VM register to be set to 0Ch (see [Figure 8](#)).

13.4 Combined space modes

The Program and Data spaces are combined into one memory space that allows the primary Flash memory, secondary Flash memory, and SRAM to be accessed by either Program Select Enable ($\overline{\text{PSEN}}$, CNTL2) or Read Strobe ($\overline{\text{RD}}$, CNTL1). For example, to configure the primary Flash memory in Combined space, bits 2 and 4 of the VM register are set to '1' (see [Figure 9](#)).

13.5 80C51XA memory map example

See the Application notes for examples.

Figure 8. 8031 memory modules - separate space

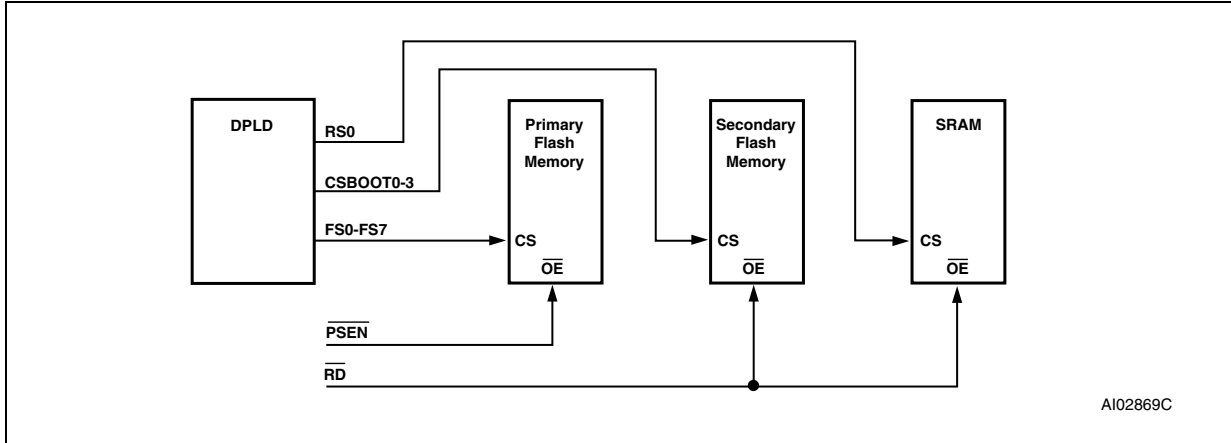
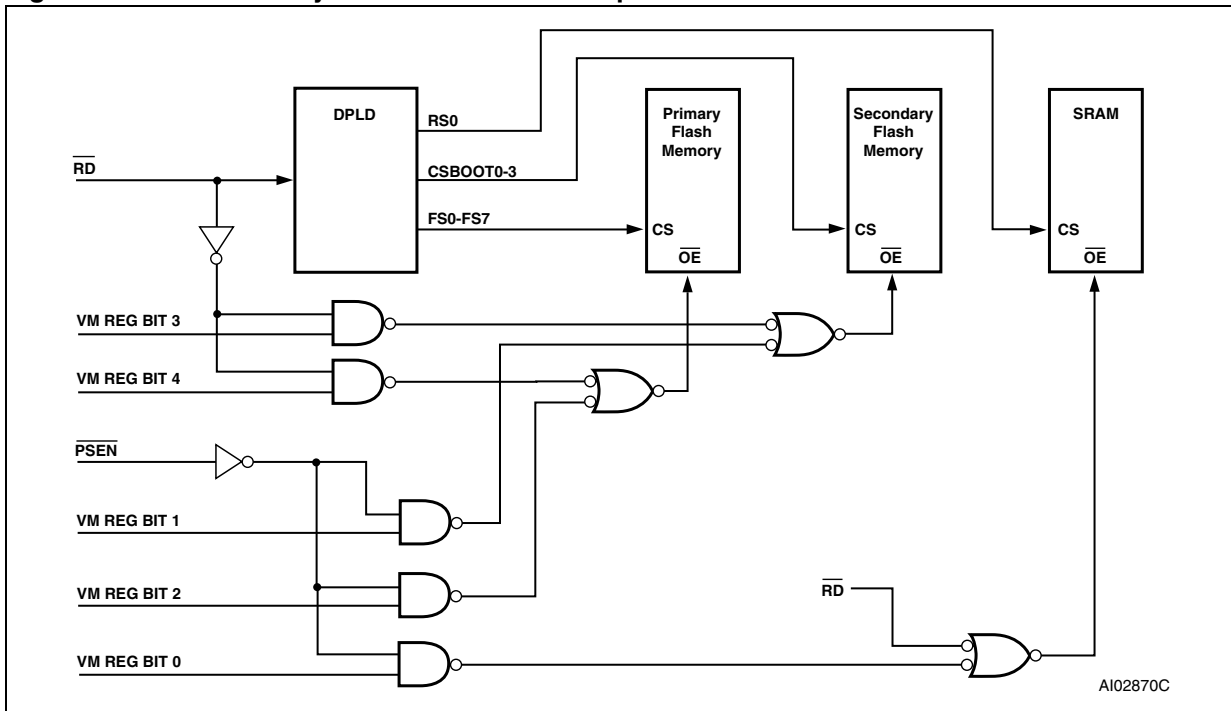

Figure 9. 8031 memory modules - combined space



14 Page register

The 8-bit Page register increases the addressing capability of the MCU by a factor of up to 256. The contents of the register can also be read by the MCU. The outputs of the Page register (PGR0-PGR7) are inputs to the DPLD decoder and can be included in the Sector Select (FS0-FS7, CSBOOT0-CSBOOT3), and SRAM Select (RS0) equations.

If memory paging is not needed, or if not all eight page register bits are needed for memory paging, these bits may be used in the CPLD for general logic. See Application Note AN1154.

Table 6.14 and Figure 10 show the Page register. The eight flip-flops in the register are connected to the internal data bus (D0-D7). The MCU can write to or read from the Page register. The Page register can be accessed at address location CSiop + E0h.

Figure 10. Page register

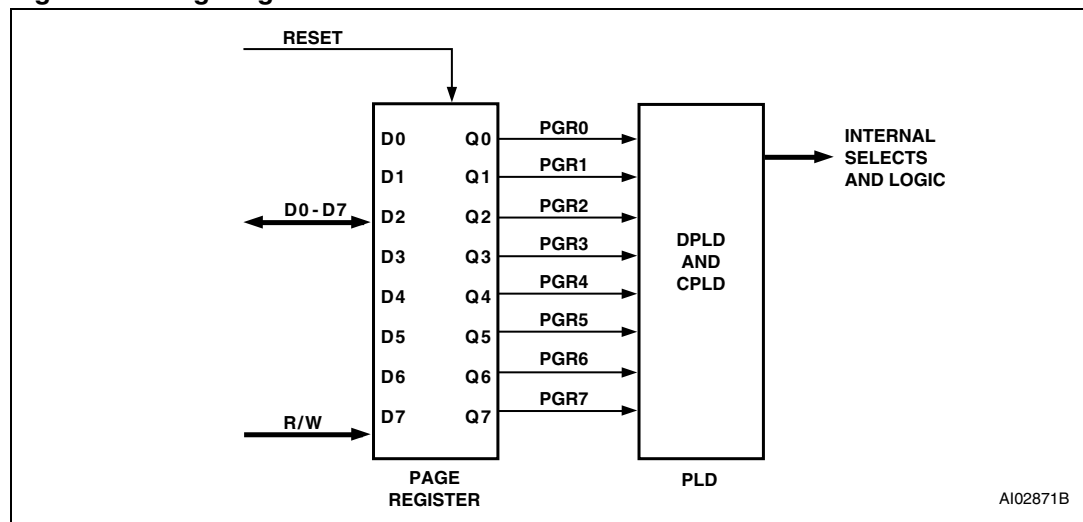

15 Memory ID registers

The 8-bit Read-only Memory Status registers are included in the CSIOP space. The user can determine the memory configuration of the PSD device by reading the Memory ID0 and Memory ID1 registers. The content of the registers is defined as shown in [Table 26](#) and [Table 27](#).

16 PLDS

The PLDs bring programmable logic functionality to the PSD. After specifying the logic for the PLDs using PSDsoft Express, the logic is programmed into the device and available upon Power-up.

The PSD contains two PLDs: the Decode PLD (DPLD), and the Complex PLD (CPLD). The PLDs are briefly discussed in the next few paragraphs, and in more detail in the following sections. [Figure 11](#) shows the configuration of the PLDs.

The DPLD performs address decoding for internal components, such as memory, registers, and I/O ports Select signals.

The CPLD can be used for logic functions, such as loadable counters and shift registers, state machines, and encoding and decoding logic. These logic functions can be constructed using the 16 output macrocells (OMC), 24 input macrocells (IMC), and the AND Array. The CPLD can also be used to generate External Chip Select (ECS0-ECS2) signals.

The AND Array is used to form product terms. These product terms are specified using PSDsoft Express. An input Bus consisting of 82 signals is connected to the PLDs. The signals are shown in [Table 32](#).

The Turbo bit in PSD

The PLDs in the PSD4235G2 can minimize power consumption by switching to standby when inputs remain unchanged for an extended time of about 70 ns. Resetting the Turbo bit to '0' (Bit 3 of the PMMR0 register) automatically places the PLDs into standby if no inputs are changing. Turning the Turbo mode off increases propagation delays while reducing power consumption. See [Section 21: Power management](#), on how to set the Turbo bit.

Additionally, five bits are available in the PMMR2 register to block MCU control signals from entering the PLDs. This reduces power consumption and can be used only when these MCU control signals are not used in PLD logic equations.

Each of the two PLDs has unique characteristics suited for its applications. They are described in the following sections.

Table 32. DPLD and CPLD inputs

Input source	Input name	Number of signals
MCU address bus ⁽¹⁾	A15-A0	16
MCU control signals	CNTL0-CNTL2	3
Reset	\overline{RST}	1
Power-down	PDN	1
Port A input macrocells	PA7-PA0	8
Port B input macrocells	PB7-PB0	8
Port C input macrocells	PC7-PC0	8
Port D inputs	PD3-PD0	4
Port F inputs	PF7-PF0	8

Table 32. DPLD and CPLD inputs (continued)

Input source	Input name	Number of signals
Page register	PGR7-PGR0	8
Macrocell A feedback	MCELLA.FB7-FB0	8
Macrocell B feedback	MCELLB.FB7-FB0	8
Flash memory Program Status bit	Ready/ $\overline{\text{Busy}}$	1

1. The address inputs are A19-A4 in 80C51XA mode.

Figure 11. PLD diagram

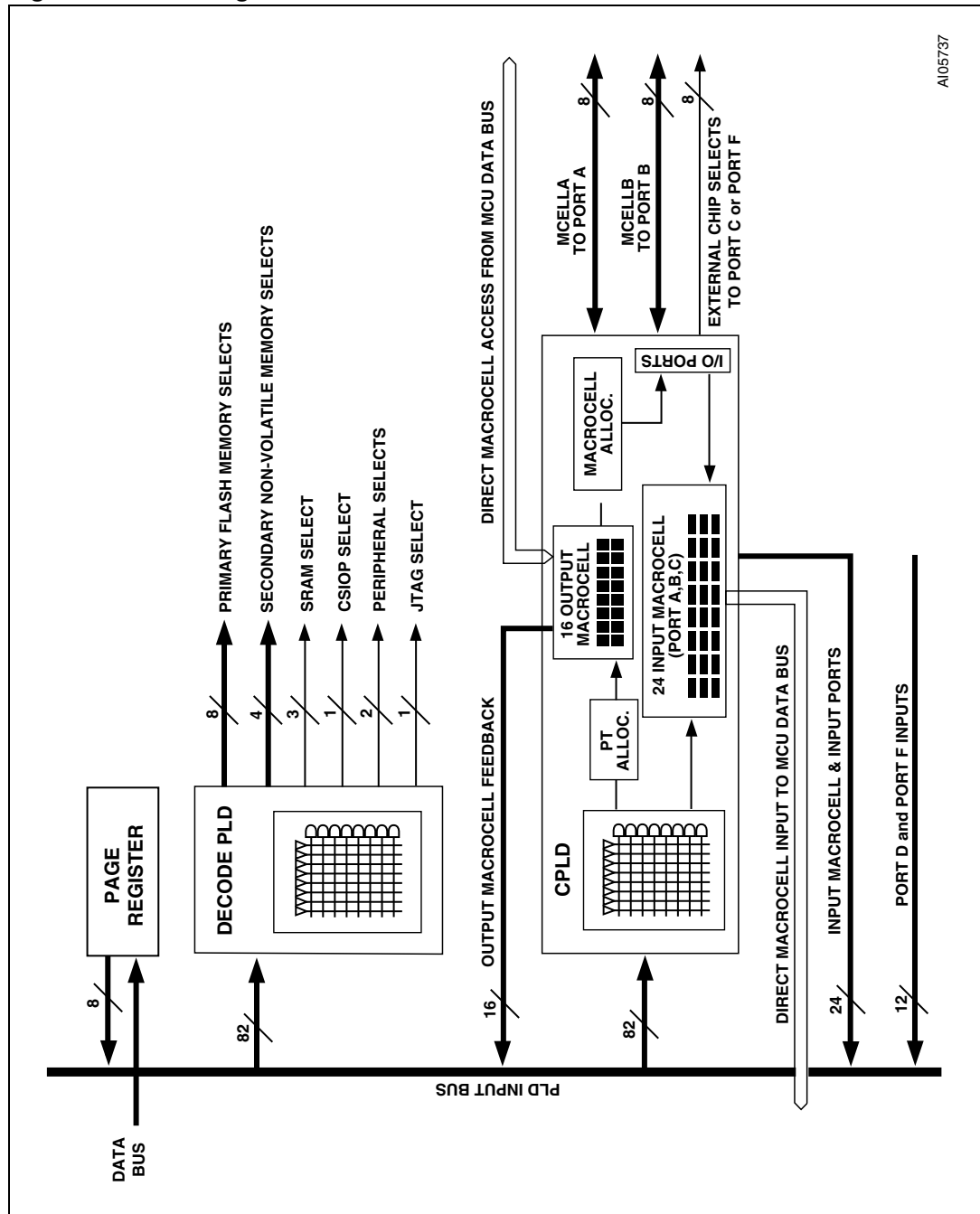

A105737

17 Decode PLD (DPLD)

The DPLD, shown in [Figure 12](#), is used for decoding the address for internal and external components. The DPLD can be used to generate the following decode signals:

- 8 Sector Select (FS0-FS7) signals for the primary Flash memory (three product terms each)
- 4 Sector Select (CSBOOT0-CSBOOT3) signals for the secondary Flash memory (three product terms each)
- 1 internal SRAM Select (RS0) signal (three product terms)
- 1 internal CSIOP Select (PSD Configuration register) signal
- 1 JTAG Select signal (enables JTAG-ISP on Port E)
- 2 internal Peripheral Select signals (Peripheral I/O mode).

Figure 12. DPLD logic array

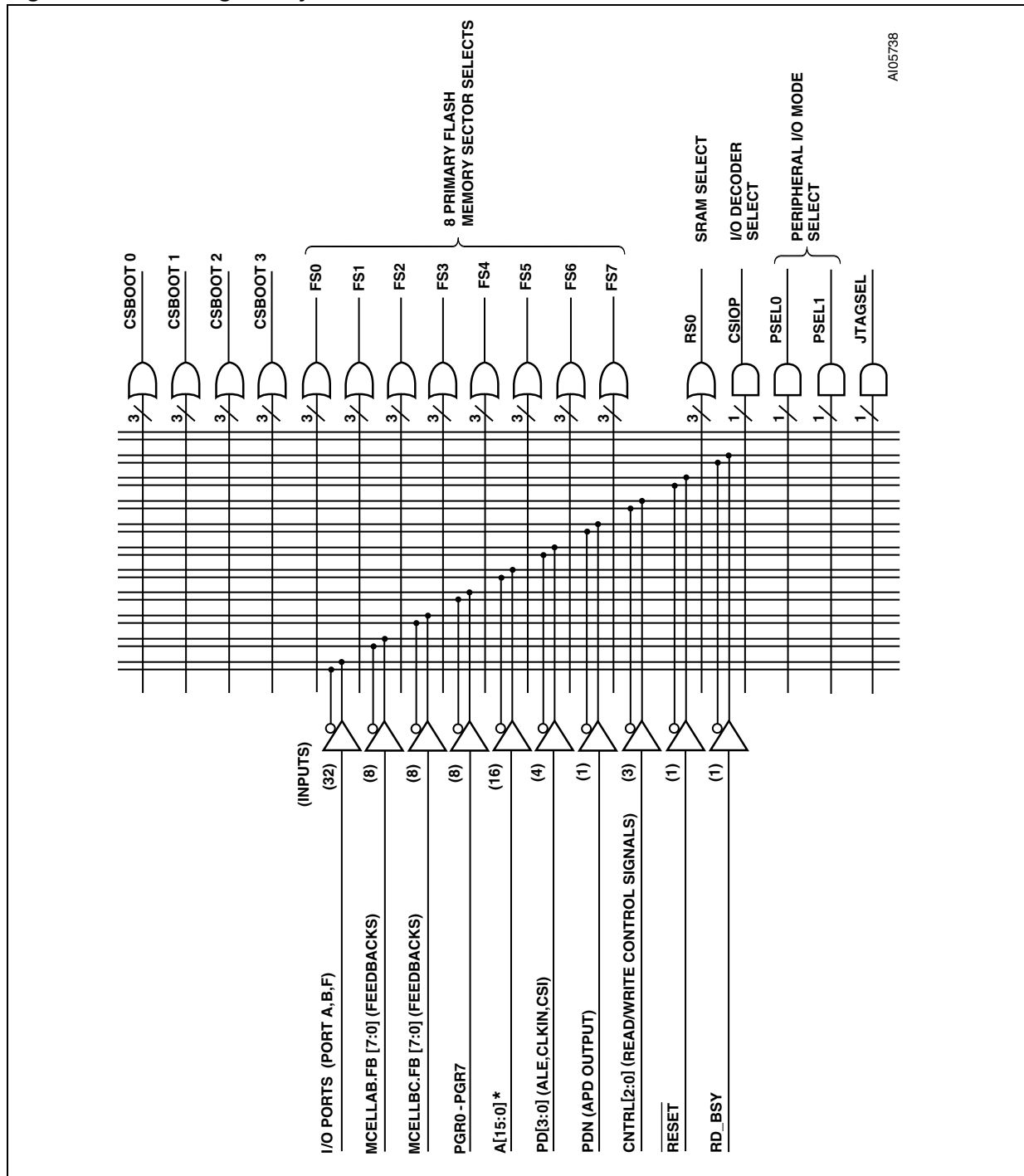

AI05738

1. The address inputs are A19-A4 when in 80C51XA mode
2. Additional address lines can be brought into the PSD via Port A, B, C, D, or F.

18 Complex PLD (CPLD)

The CPLD can be used to implement system logic functions, such as loadable counters and shift registers, system mailboxes, handshaking protocols, state machines, and random logic. The CPLD can also be used to generate eight External Chip Select (ECS0-ECS7), routed to Port C or Port F.

Although External Chip Select (ECS0-ECS7) can be produced by any output macrocell (OMC), these eight External Chip Select (ECS0-ECS7) on Port C or Port F do not consume any output macrocells (OMC).

As shown in [Figure 11](#), the CPLD has the following blocks:

- 24 input macrocells (IMC)
- 16 output macrocells (OMC)
- Product Term Allocator
- AND Array capable of generating up to 196 product terms
- Four I/O Ports.

Each of the blocks are described in the sections that follow.

The input macrocells (IMC) and output macrocells (OMC) are connected to the PSD internal data bus and can be directly accessed by the MCU. This enables the MCU software to load data into the output macrocells (OMC) or read data from both the input and output macrocells (IMC and OMC).

This feature allows efficient implementation of system logic and eliminates the need to connect the data bus to the AND Array as required in most standard PLD macrocell architectures.

Figure 13. Macrocell and I/O port

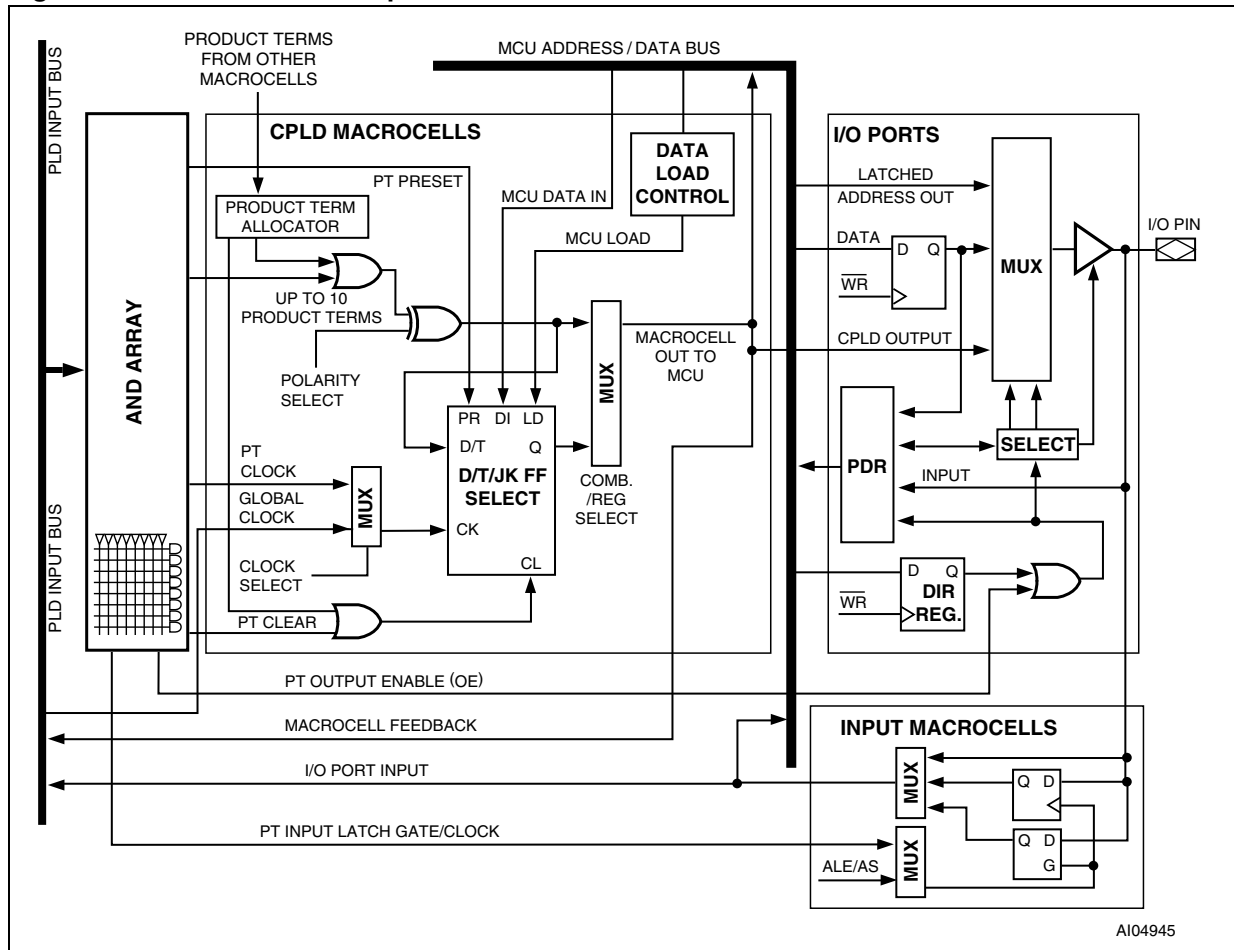

18.1 Output macrocell (OMC)

Eight of the output macrocells (OMC) are connected to Ports A pins and are named as McellA0-McellA7. The other eight macrocells are connected to Ports B pins and are named as McellB0-McellB7.

The output macrocell (OMC) architecture is shown in [Figure 14](#). As shown in the figure, there are native product terms available from the AND Array, and borrowed product terms available (if unused) from other output macrocells (OMC). The polarity of the product term is controlled by the XOR gate. The output macrocell (OMC) can implement either sequential logic, using the flip-flop element, or combinatorial logic. The multiplexer selects between the sequential or combinatorial logic outputs. The multiplexer output can drive a port pin and has a feedback path to the AND Array inputs.

The flip-flop in the output macrocell (OMC) block can be configured as a D, T, JK, or SR type in the PSDsoft Express program. The flip-flop's clock, preset, and clear inputs may be driven from a product term of the AND Array. Alternatively, the external CLKIN (PD1) signal can be used for the clock input to the flip-flop. The flip-flop is clocked on the rising edge of CLKIN (PD1). The preset and clear are active high inputs. Each clear input can use up to two product terms.

Table 33. Output macrocell Port and Data bit Assignments

Output Macrocell	Port Assignment	Native Product Terms	Maximum Borrowed Product Terms	Data bit for Loading or Reading	Motorola 16-Bit MCU for Loading or Reading
McellA0	Port A0	3	6	D0	D8
McellA1	Port A1	3	6	D1	D9
McellA2	Port A2	3	6	D2	D10
McellA3	Port A3	3	6	D3	D11
McellA4	Port A4	3	6	D4	D12
McellA5	Port A5	3	6	D5	D13
McellA6	Port A6	3	6	D6	D14
McellA7	Port A7	3	6	D7	D15
McellB0	Port B0	4	5	D8	D0
McellB1	Port B1	4	5	D9	D1
McellB2	Port B2	4	5	D10	D2
McellB3	Port B3	4	5	D11	D3
McellB4	Port B4	4	6	D12	D4
McellB5	Port B5	4	6	D13	D5
McellB6	Port B6	4	6	D14	D6
McellB7	Port B7	4	6	D15	D7

18.2 Product Term Allocator

The CPLD has a Product Term Allocator. PSDsoft Express, uses the Product Term Allocator to borrow and place product terms from one macrocell to another. The following list summarizes how product terms are allocated:

- McellA0-McellA7 all have three native product terms and may borrow up to six more
- McellB0-McellB3 all have four native product terms and may borrow up to five more
- McellB4-McellB7 all have four native product terms and may borrow up to six more.

Each macrocell may only borrow product terms from certain other macrocells. Product terms already in use by one macrocell are not available for another macrocell.

If an equation requires more product terms than are available to it, then “external” product terms are required, which consume other output macrocells (OMC). If external product terms are used, extra delay is added for the equation that required the extra product terms. This is called product term expansion. PSDsoft Express performs this expansion as needed.

18.3 Loading and Reading the output macrocells (OMC)

The output macrocells (OMC) block occupies a memory location in the MCU address space, as defined by the CSIOP (see [Section 20: I/O ports](#)). The flip-flops in each of the 16 output macrocells (OMC) can be loaded from the data bus by a MCU. Loading the output macrocells (OMC) with data from the MCU takes priority over internal functions. As such, the preset, clear, and clock inputs to the flip-flop can be overridden by the MCU. The ability to load the flip-flops and read them back is useful in such applications as loadable counters and shift registers, mailboxes, and handshaking protocols.

Data is loaded to the output macrocells (OMC) on the trailing edge of Write Strobe (WR/WRL, CNTLO).

18.4 The OMC Mask register

There is one Mask register for each of the two groups of eight output macrocells (OMC). The Mask registers can be used to block the loading of data to individual output macrocells (OMC). The default value for the Mask registers is 00h, which allows loading of the output macrocells (OMC). When a given bit in a Mask register is set to a '1,' the MCU is blocked from writing to the associated output macrocells (OMC). For example, suppose McellA0-McellA3 are being used for a state machine. You would not want an MCU WRITE to McellA to overwrite the state machine registers. Therefore, you would want to load the Mask register for McellA (Mask macrocell A) with the value 0Fh.

18.5 The output Enable of the OMC

The output macrocells (OMC) can be connected to an I/O port pin as a PLD output. The output enable of each port pin driver is controlled by a single product term from the AND Array, ORed with the Direction register output. The pin is enabled upon Power-up if no output enable equation is defined and if the pin is declared as a PLD output in PSDsoft Express.

If the output macrocell (OMC) output is declared as an internal node and not as a port pin output in the PSDlabel file, then the port pin can be used for other I/O functions. The internal node feedback can be routed as an input to the AND Array.

Figure 14. CPLD output macrocell

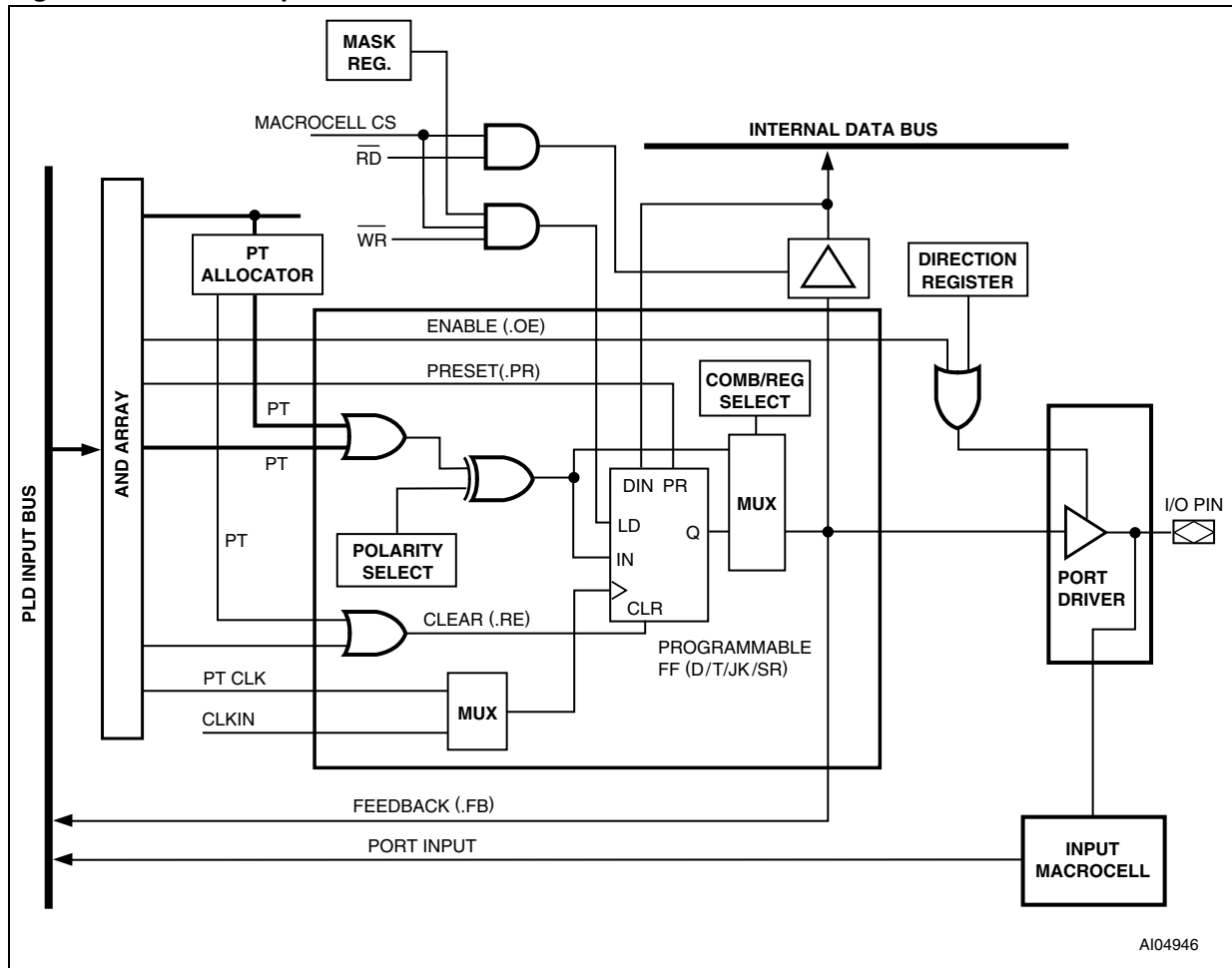

AI04946

18.6 Input macrocells (IMC)

The CPLD has 24 input macrocells (IMC), one for each pin on Ports A, B, and C. The architecture of the input macrocells (IMC) is shown in [Figure 15](#). The input macrocells (IMC) are individually configurable, and can be used as a latch, register, or to pass incoming Port signals prior to driving them onto the PLD input bus. The outputs of the input macrocells (IMC) can be read by the MCU through the internal data bus.

The enable for the latch and clock for the register are driven by a multiplexer whose inputs are a product term from the CPLD AND Array or the MCU Address Strobe (ALE/AS). Each product term output is used to latch or clock four input macrocells (IMC). Port inputs 3-0 can be controlled by one product term and 7-4 by another.

Configurations for the input macrocells (IMC) are specified by PSDsoft Express (see Application Note [AN1171](#)). outputs of the input macrocells (IMC) can be read by the MCU via the IMC buffer (see [Section 20: I/O ports](#)).

Input macrocells (IMC) can use Address Strobe (ALE/AS, PD0) to latch address bits higher than A15. Any latched addresses are routed to the PLDs as inputs.

18.7 External Chip Select

The CPLD also provides eight External Chip Select (ECS0-ECS7) outputs that can be used to select external devices. Each External Chip Select (ECS0-ECS7) consists of one product term that can be configured active high or low.

The output enable of the pin is controlled by either the output enable product term or the Direction register. (See [Figure 16](#).)

Figure 16. External Chip Select signal

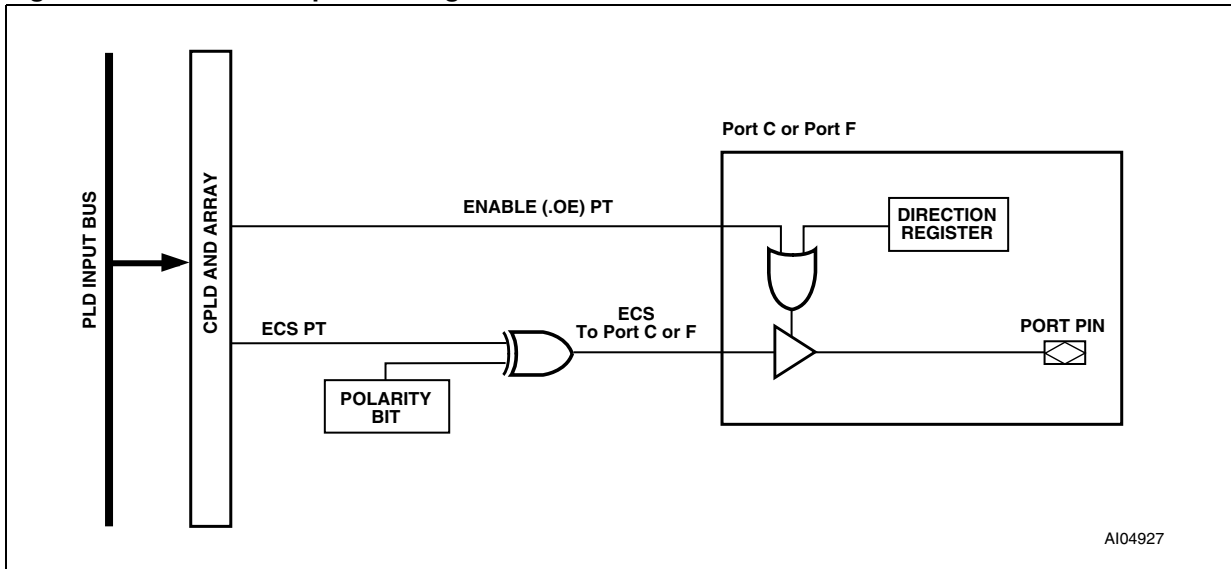

19 MCU bus interface

The “no-glue logic” MCU Bus Interface block can be directly connected to most popular MCUs and their control signals. Key 16-bit MCUs, with their bus types and control signals, are shown in [Table 34](#). The MCU interface type is specified using the PSDsoft Express.

Table 34. MCUs and their control signals

MCU	CNTL0	CNTL1	CNTL2	PD3	PD0 ⁽¹⁾	ADIO0	PF3-PF0
68302, 68306, MMC2001	R/ \bar{W}	LDS	UDS	⁽²⁾	AS	—	⁽²⁾
68330, 68331, 68332, 68340	R/ \bar{W}	DS	SIZ0	⁽²⁾	AS	A0	⁽²⁾
68LC302, MMC2001	WEL	OE	—	WEH	AS	—	⁽²⁾
68HC16	R/ \bar{W}	DS	SIZ0	⁽²⁾	AS	A0	⁽²⁾
68HC912	R/ \bar{W}	E	LSTRB	DBE	E	A0	⁽²⁾
68HC812 ³	R/ \bar{W}	E	LSTRB	⁽²⁾	(Note ¹)	A0	⁽²⁾
80196	WR	RD	BHE	⁽²⁾	ALE	A0	⁽²⁾
80196SP	WRL	RD	(Note ¹)	WRH	ALE	A0	⁽²⁾
80186	WR	RD	BHE	⁽²⁾	ALE	A0	⁽²⁾
80C161, 80C164-80C167	WR	RD	BHE	⁽²⁾	ALE	A0	⁽²⁾
80C51XA	WRL	RD	PSEN	WRH	ALE	A4/D0	A3-A1
H8/300	WRL	RD	⁽²⁾	WRH	AS	A0	—
M37702M2	R/ \bar{W}	E	BHE	⁽²⁾	ALE	A0	⁽²⁾

1. ALE/AS input is optional for MCUs with a non-multiplexed bus
2. Unused CNTL2 pin can be configured as CPLD input. Other unused pins (PD3-PD0, PF3-PF0) can be configured for other I/O functions.

19.1 PSD interface to a multiplexed bus

Figure 18 shows an example of a system using a MCU with a 16-bit multiplexed bus and a PSD4235G2. The ADIO port on the PSD is connected directly to the MCU address/data bus. Address Strobe (ALE/AS, PD0) latches the address signals internally. Latched addresses can be brought out to Port E, F or G. The PSD drives the ADIO data bus only when one of its internal resources is accessed and Read Strobe (\overline{RD} , CNTRL1) is active. Should the system address bus exceed sixteen bits, Ports A, B, C, or F may be used as additional address inputs.

Figure 18. An example of a typical 16-bit multiplexed bus interface

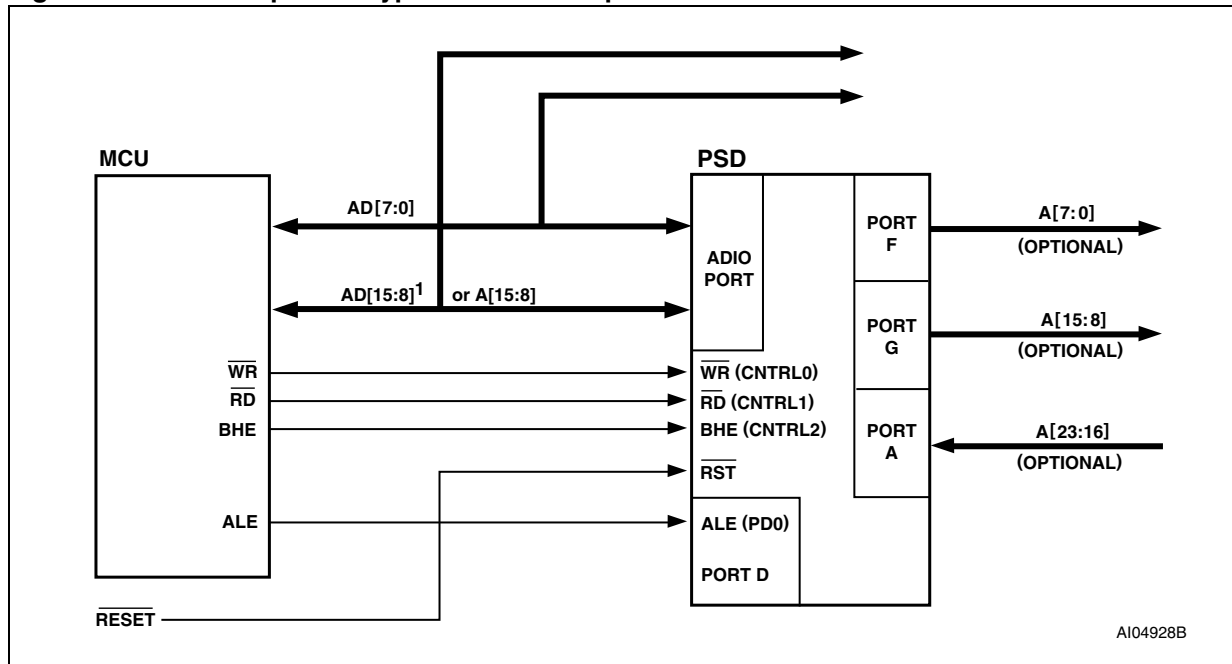

19.2 PSD interface to a non-multiplexed 8-bit bus

Figure 19 shows an example of a system using a MCU with a 16-bit non-multiplexed bus and a PSD4235G2. The address bus is connected to the ADIO Port, and the data bus is connected to Ports F and G. Ports F and G are in tri-state mode when the PSD is not accessed by the MCU. Should the system address bus exceed sixteen bits, Ports A, B, or C may be used for additional address inputs.

Figure 19. An example of a typical 16-bit non-multiplexed bus interface

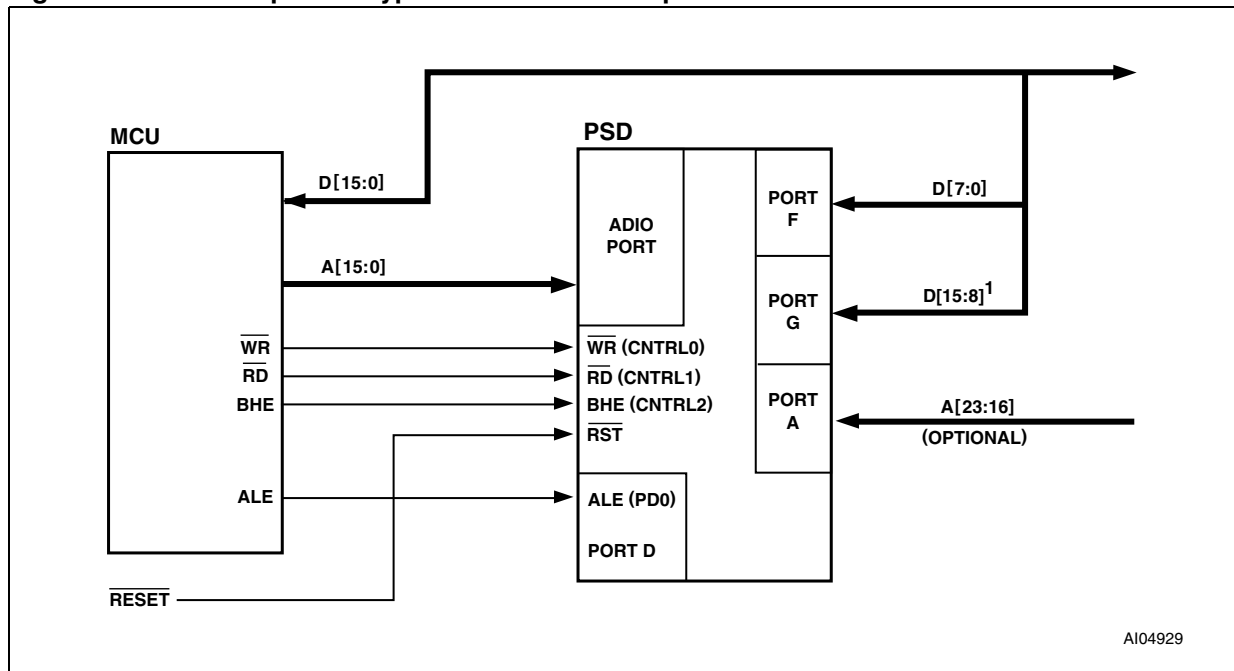

19.3 Data Byte Enable reference

MCUs have different data byte orientations. Table 35 to Table 38 show how the PSD4235G2 interprets byte/word operations in different bus write configurations. Even-byte refers to locations with address A0 equal to '0,' and odd byte as locations with A0 equal to '1.'

Table 35. 16-bit data bus with BHE

BHE	A0	D15-D8	D7-D0
0	0	Odd Byte	Even Byte
0	1	Odd Byte	—
1	0	—	Even Byte

19.4 MCU bus interface examples

Figure 20 to Figure 25 show examples of the basic connections between the PSD4235G2 and some popular MCUs. The PSD4235G2 Control input pins are labeled as to the MCU function for which they are configured. The MCU bus interface is specified using PSDsoft Express.

Table 36. 16-bit data bus with WRH and WRL

WRH	WRL	D15-D8	D7-D0
0	0	Odd Byte	Even Byte
0	1	Odd Byte	—
1	0	—	Even Byte

Table 37. 16-bit data bus with SIZ0, A0 (Motorola MCU)

SIZ0	A0	D15-D8	D7-D0
0	0	Even Byte	Odd Byte
1	0	Even Byte	—
1	1	—	Odd Byte

Table 38. 16-bit data bus with LDS, UDS (Motorola MCU)

WRH	WRL	D15-D8	D7-D0
0	0	Even Byte	Odd Byte
1	0	Even Byte	—
0	1	—	Odd Byte

19.5 80C196 and 80C186

In *Figure 20*, the Intel 80C196 MCU, which has a 16-bit multiplexed address/data bus, is shown connected to a PSD4235G2. The Read Strobe (RD, CNTL1), and Write Strobe (WR/WRL, CNTL0) signals are connected to the CNTL pins. When BHE is not used, the PSD can be configured to receive WRL and Write Enable high-byte (WRH/DBE, PD3) from the MCU. higher address inputs (A16-A19) can be routed to Ports A, B, or C as input of the PLD.

The AMD 80186 family has the same bus connection to the PSD as the 80C196.

Figure 20. Interfacing the PSD with an 80C196

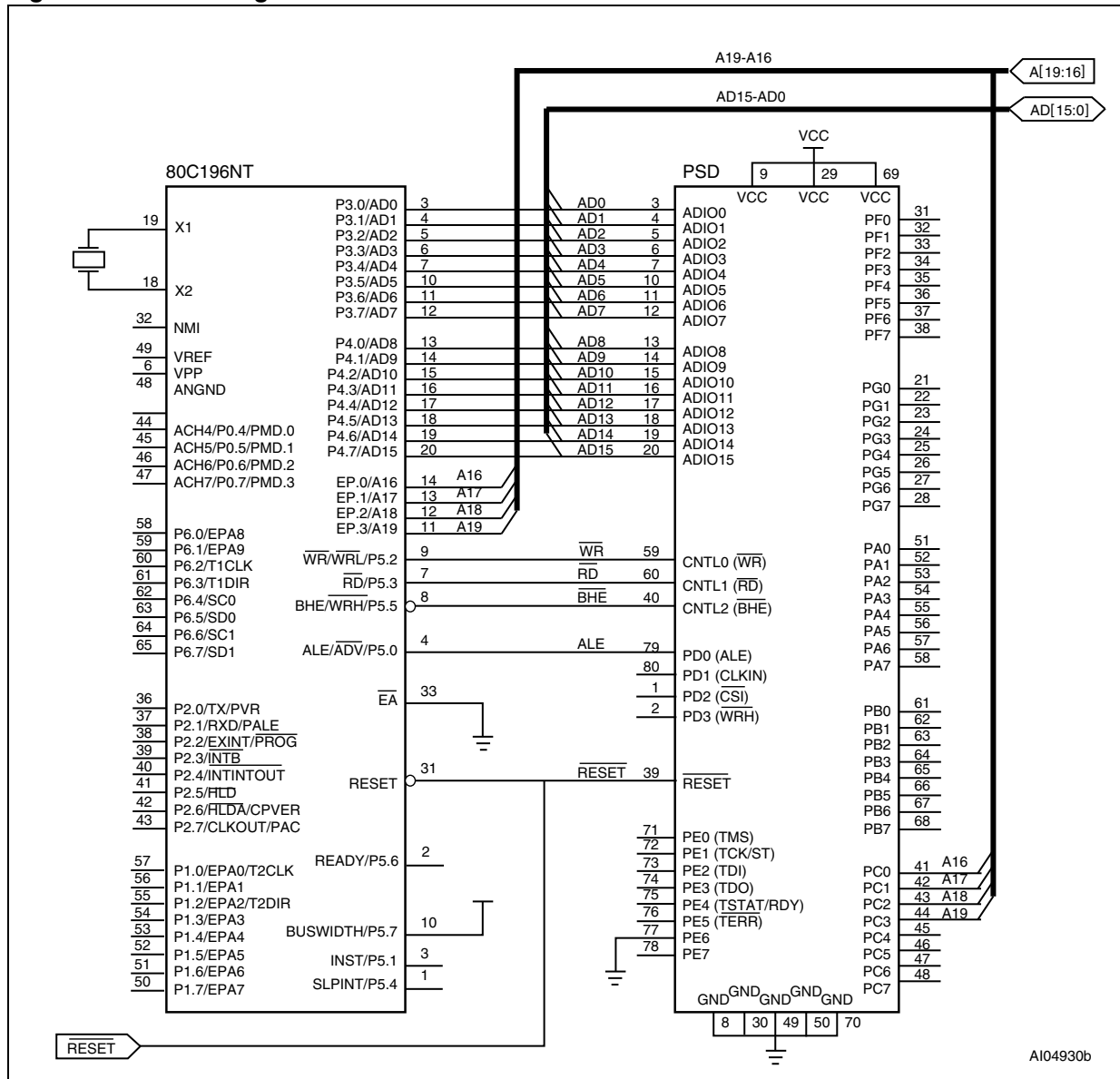

19.6 MC683xx and MC68HC16

Figure 21 shows a MC68331 with a 16-bit non-multiplexed data bus and 24-bit address bus. The data bus from the MC68331 is connected to Port F (D0-D7) and Port G (D8-D15). The SIZ0 and A0 inputs determine the high/low byte selection. The R/W, DS and SIZ0 signals are connected to the CNTL0-CNTL2 pins.

The MC68HC16, and other members of the MC683xx family, has the same bus connection to the PSD as the MC68331 shown in Figure 21.

Figure 21. Interfacing the PSD with an MC68331

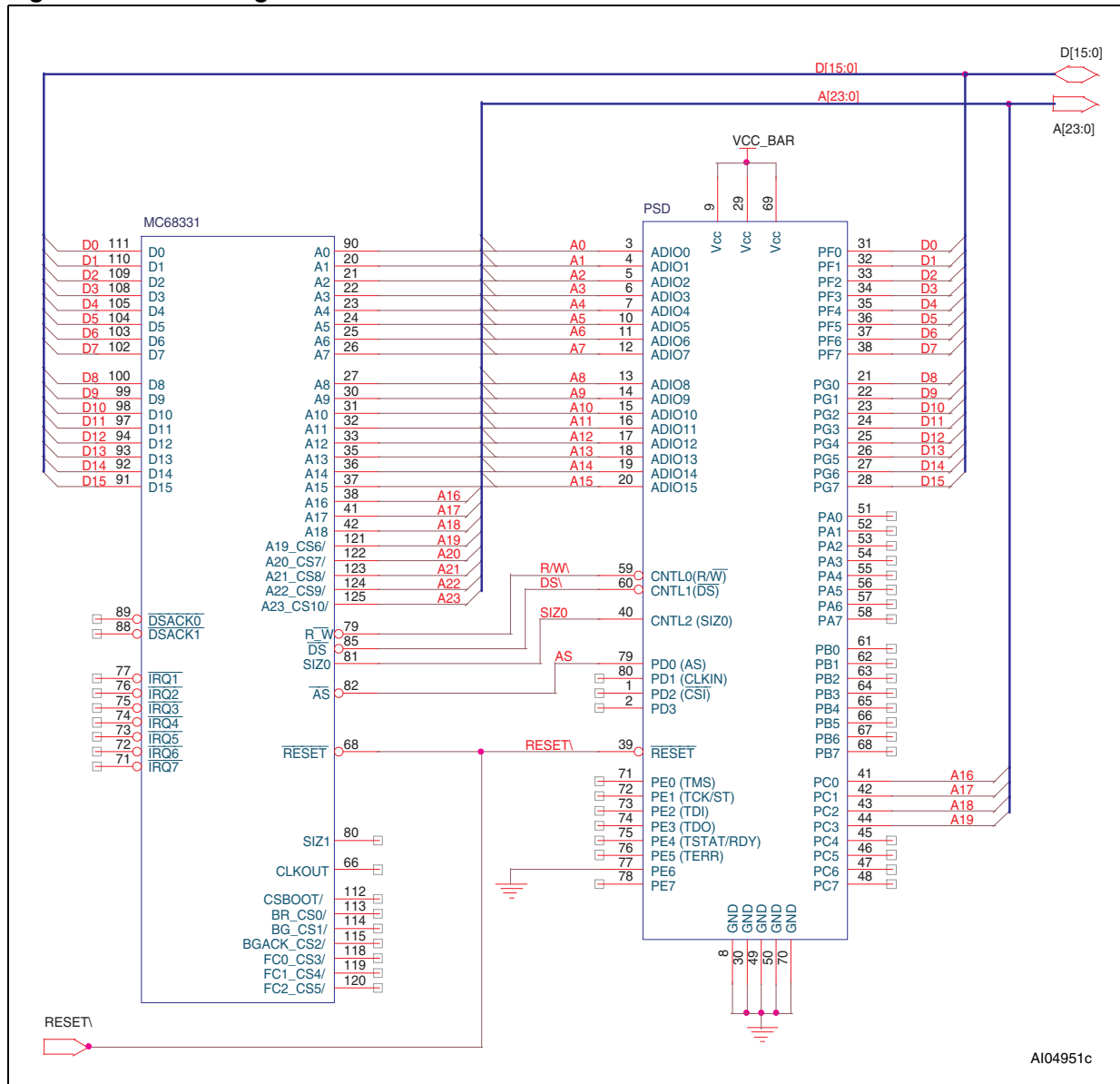

19.7 80C51XA

The Philips 80C51XA MCU has a 16-bit multiplexed bus with burst cycles. Address bits (A3-A1) are not multiplexed, while (A19-A4) are multiplexed with data bits (D15-D0).

The PSD4235G2 supports the 80C51XA burst mode. The \overline{WRH} signal is connected to PD3, and \overline{WHL} is connected to CNTL0. The \overline{RD} and \overline{PSEN} signals are connected to the CNTL1 and CNTL2 pins. *Figure 22* shows the schematic diagram.

The 80C51XA improves bus throughput and performance by issuing burst cycles to fetch codes from memory. In burst cycles, address A19-A4 are latched internally by the PSD, while the 80C51XA drives the A3-A1 signals to fetch sequentially up to 16 bytes of code. The PSD access time is then measured from address A3-A1 valid to data in valid. The PSD bus timing requirement in a burst cycle is identical to the normal bus cycle, except the address setup and hold time with respect to Address Strobe (ALE/AS, PD0) is not required.

Figure 22. Interfacing the PSD with an 80C51XA-G3

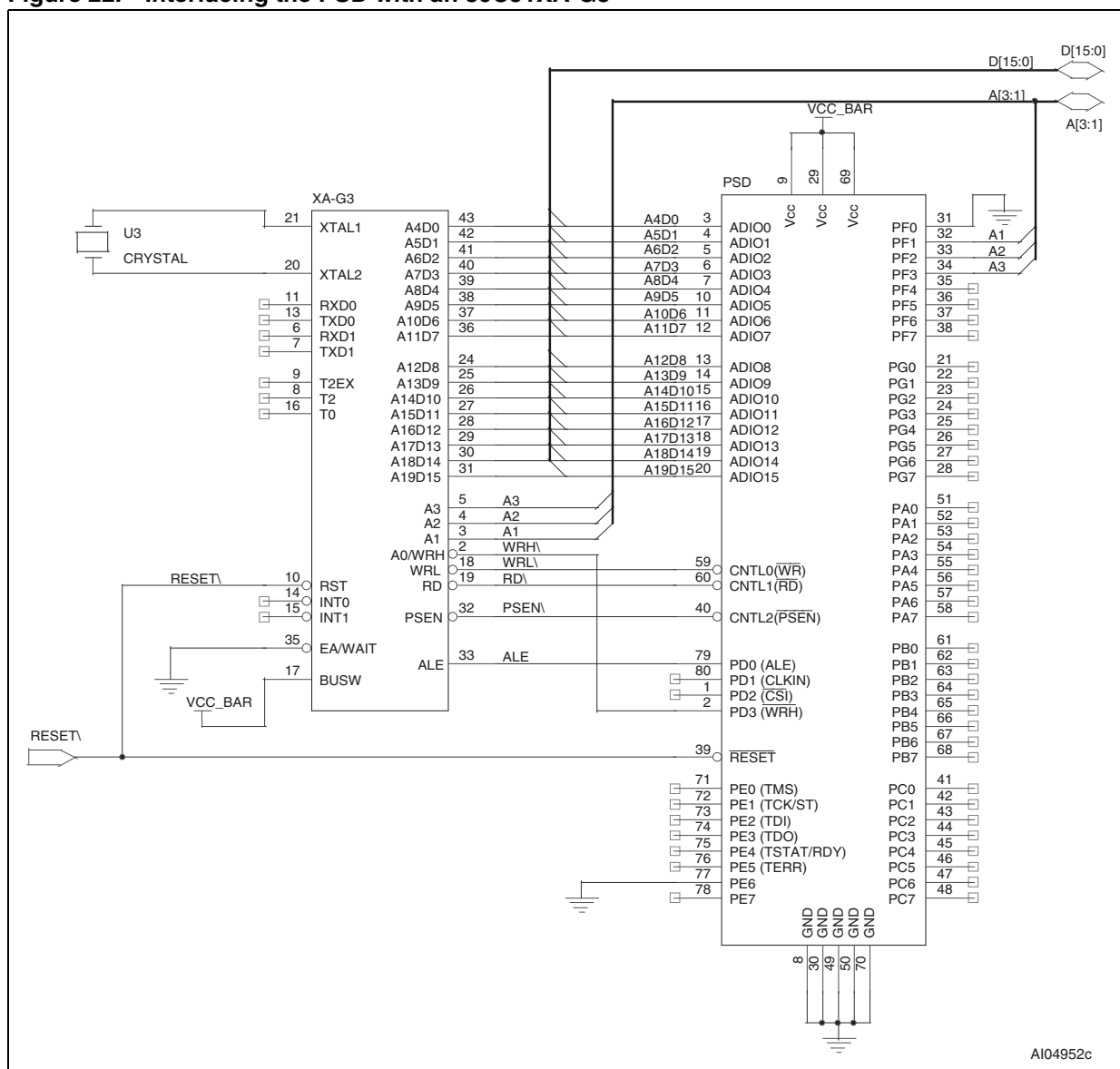

19.8 H8/300

Figure 23 shows an Hitachi H8/2350 with a 16-bit non-multiplexed data bus, and a 24-bit address bus. The H8 data bus is connected to Port F (D0-D7) and Port G (D8-D15).

The \overline{WRH} signal is connected to PD3, and \overline{WHL} is connected to CNTL0. The \overline{RD} signal is connected to CNTL1. The connection to the Address Strobe (AS) signal is optional, and is required if the addresses are to be latched.

Figure 23. Interfacing the PSD with an H83/2350

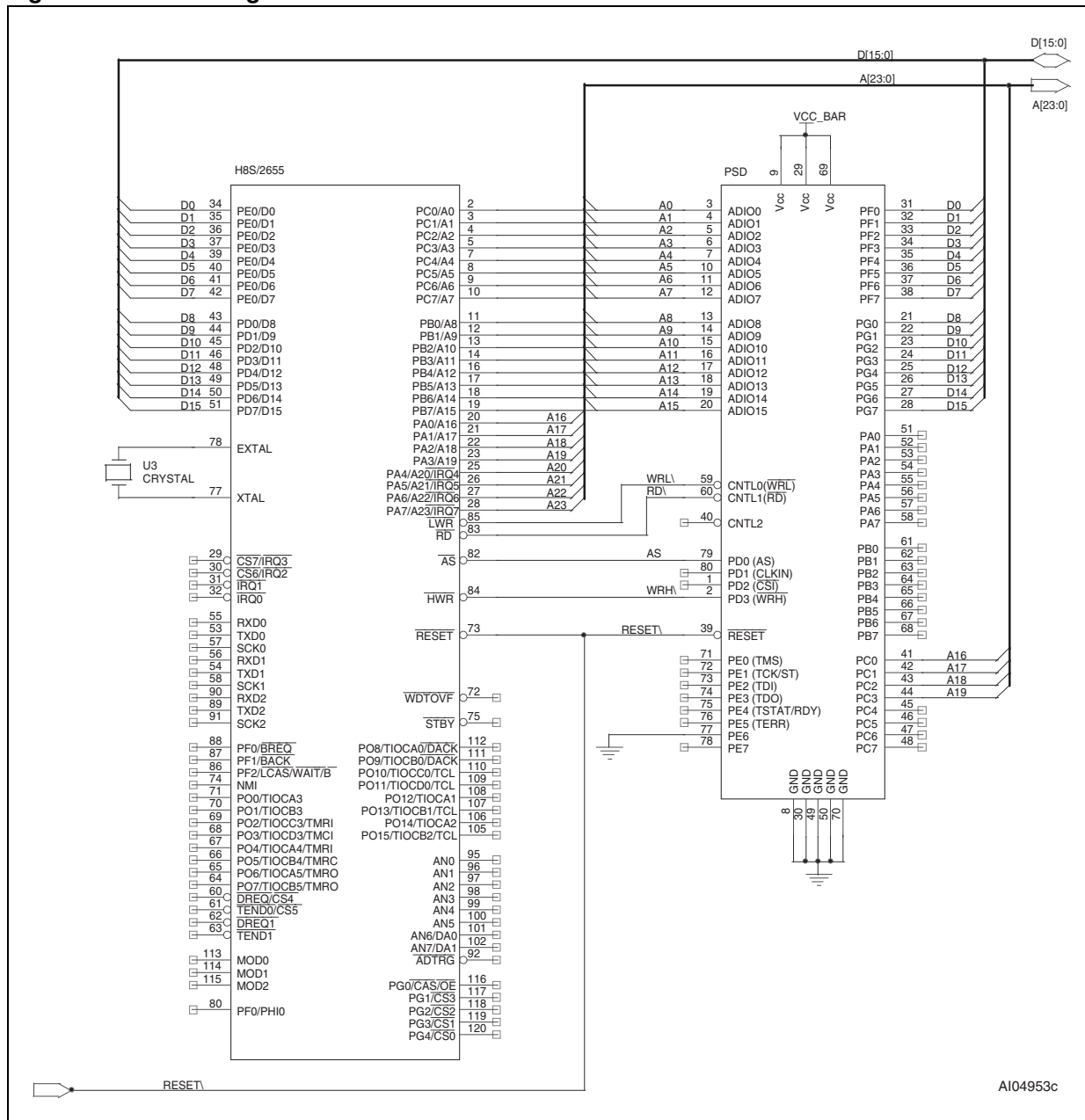

19.9 MMC2001

The Motorola MCORE MMC2001 MCU has a MOD input pin that selects internal or external boot ROM. The PSD can be configured as the external flash boot ROM or as extension to the internal ROM.

The MMC2001 has a 16-bit external data bus and 20 address lines with external chip select signals. The Chip Select Control registers allow the user to customize the bus interface and timing to fit the individual system requirement. A typical interface configuration to the PSD is shown in [Figure 24](#). The MMC2001's $\overline{R/\overline{W}}$ signal is connected to the CNTL0 pin, while $\overline{EB0}$ and $\overline{EB1}$ (enable byte-0 and enable byte-1) are connected to the CNTL1 (\overline{UDS}) and CNTL2 (\overline{LDS}) pins. The WEN bit in the Chip Select Control register should be set to '1' to terminate the $\overline{EB0}$ - $\overline{EB1}$ earlier to provide the write data hold time for the PSD. The WSC and WWS bits in the Control register are set to wait states that meet the PSD access time requirement.

Another option is to configure the $\overline{EB0}$ and $\overline{EB1}$ as \overline{WRL} and \overline{WRH} signals. In this case, the PSD control setting will be: \overline{OE} , \overline{WRL} , \overline{WRH} where \overline{OE} is the READ signal for the MMC2001.

19.10 C16x family

The PSD supports Infineon's C16X family of MCUs (C161-C167) in both the multiplexed and non-multiplexed bus configuration. In [Figure 25](#), the C167CR is shown connected to the PSD in a multiplexed bus configuration. The control signals from the MCU are \overline{WR} , \overline{RD} , \overline{BHE} and ALE, and are routed to the corresponding PSD pins.

The C167 has another control signal setting (\overline{RD} , \overline{WRL} , \overline{WRH} , ALE) which is also supported by the PSD.

Figure 24. Interfacing the PSD with an MMC2001

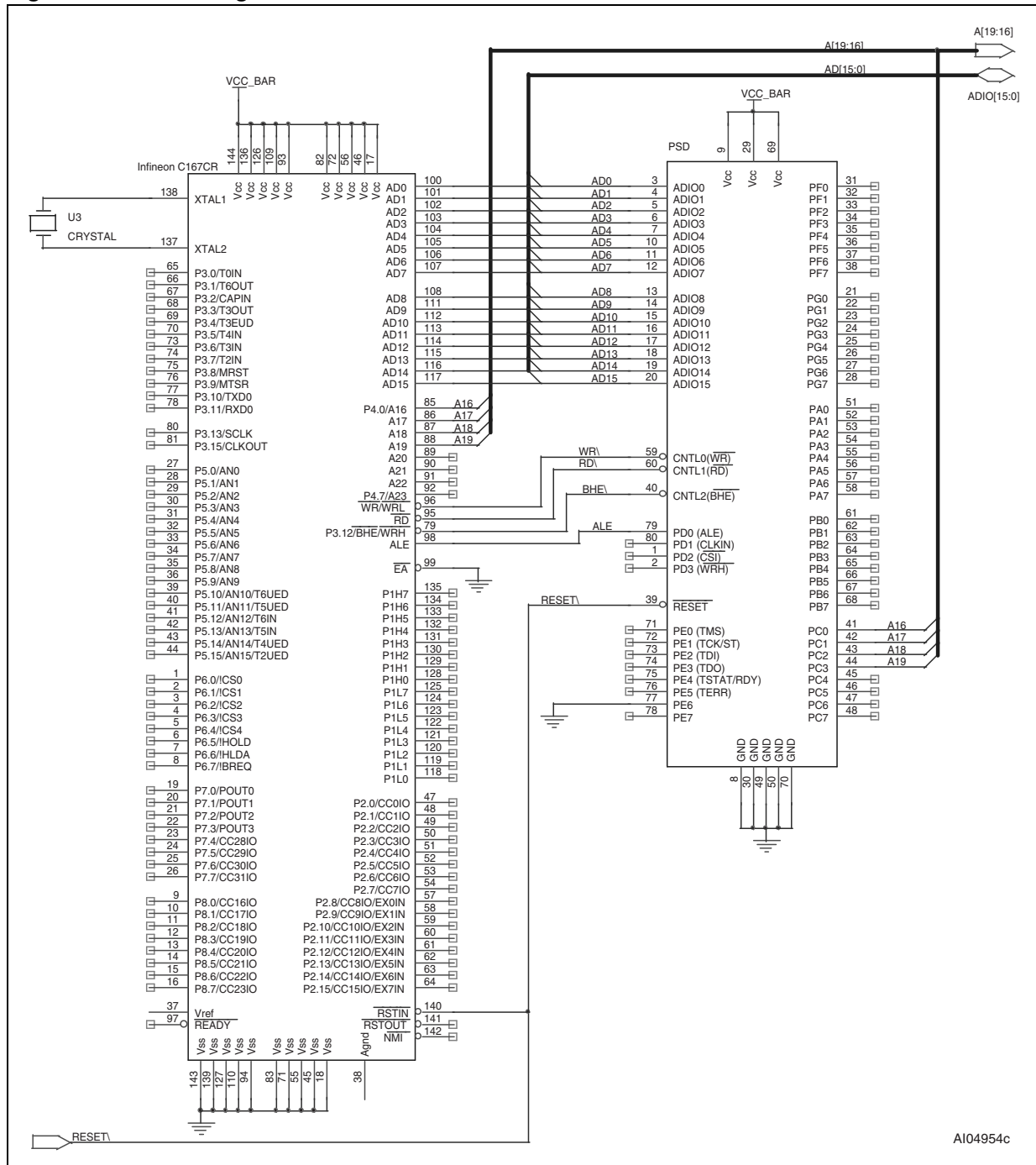

AI04954c

Figure 25. Interfacing the PSD with a C167CR

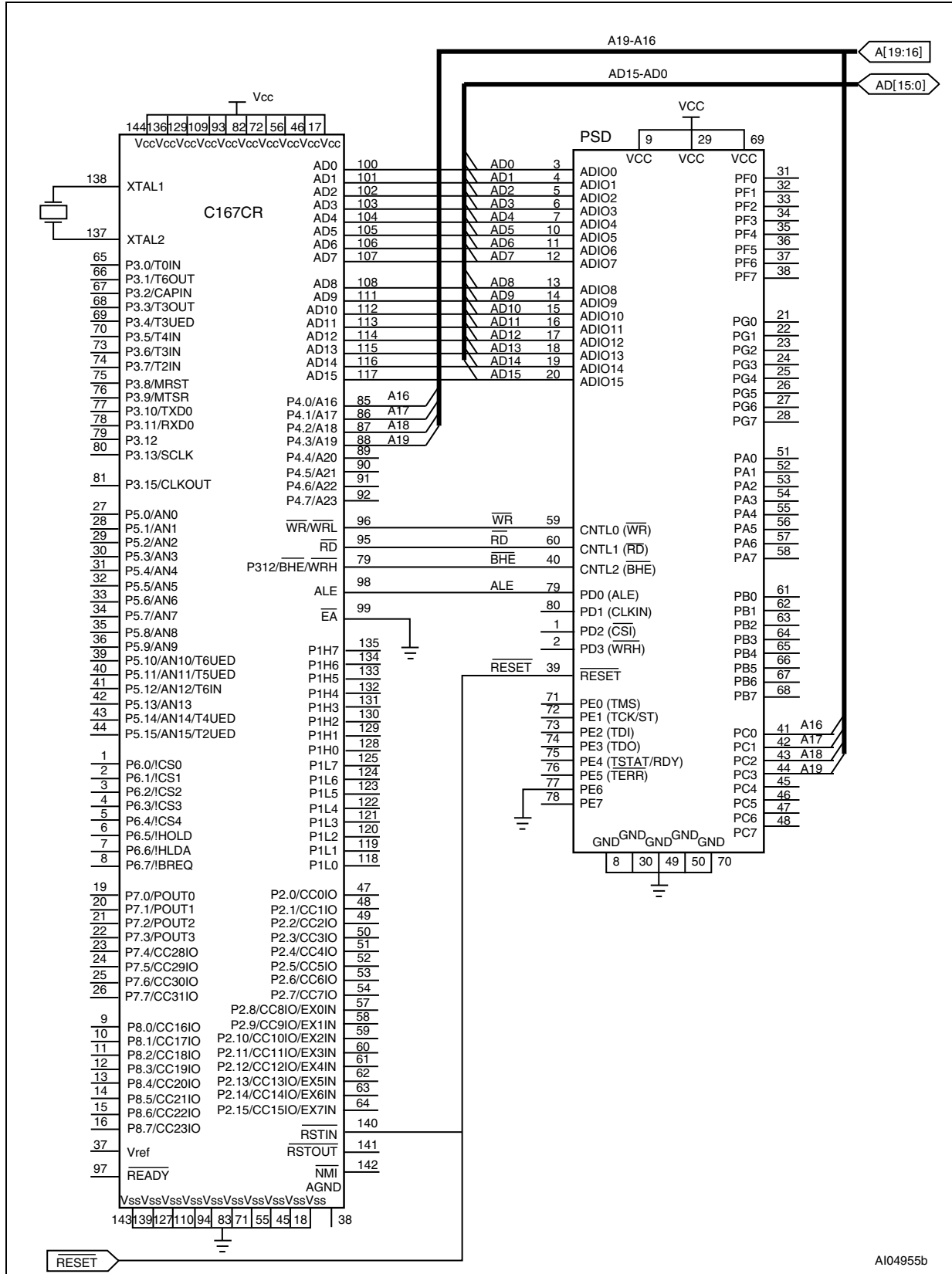

AI04955b



20 I/O ports

There are seven programmable I/O ports: Ports A, B, C, D, E, F and G. Each port pin is individually user configurable, thus allowing multiple functions per port. The ports are configured using PSDsoft Express or by the MCU writing to on-chip registers in the CSIOP space.

The topics discussed in this section are:

- General Port architecture
- Port operating modes
- Port Configuration registers (PCR)
- Port Data registers
- Individual Port functionality.

20.1 General port architecture

The general architecture of the I/O Port block is shown in [Figure 26](#). Individual Port architectures are shown in [Figure 28](#) to [Figure 30](#). In general, once the purpose for a port pin has been defined, that pin is no longer available for other purposes. Exceptions are noted.

As shown in [Figure 26](#), the ports contain an output multiplexer whose select signals are driven by the configuration bits in the Control registers (Ports E, F and G only) and PSDsoft Express Configuration. inputs to the multiplexer include the following:

- Output data from the Data Out register
- Latched address outputs
- CPLD macrocell output
- External Chip Select from the CPLD.

The Port Data Buffer (PDB) is a tri-state buffer that allows only one source at a time to be read. The Port Data Buffer (PDB) is connected to the Internal Data Bus for feedback and can be read by the MCU. The Data Out and macrocell outputs, Direction register and Control register, and port pin input are all connected to the Port Data Buffer (PDB).

The Port pin's tri-state output driver enable is controlled by a two input OR gate whose inputs come from the CPLD AND Array enable product term and the Direction register. If the enable product term of any of the Array outputs are not defined and that port pin is not defined as a CPLD output in the PSDabel file, the Direction register has sole control of the buffer that drives the port pin.

The contents of these registers can be altered by the MCU. The Port Data Buffer (PDB) feedback path allows the MCU to check the contents of the registers.

Ports A, B, and C have embedded input macrocells (IMC). The input macrocells (IMC) can be configured as latches, registers, or direct inputs to the PLDs. The latches and registers are clocked by Address Strobe (ALE/AS, PD0) or a product term from the PLD AND Array. The outputs from the input macrocells (IMC) drive the PLD input bus and can be read by the MCU (see [Figure 15: Input macrocell](#)).

20.2 Port operating modes

The I/O Ports have several modes of operation. Some modes can be defined using PSDsoft Express, some by the MCU writing to the registers in CSIOP space, and some by both. The modes that can only be defined using PSDsoft Express must be programmed into the device and cannot be changed unless the device is reprogrammed. The modes that can be changed by the MCU can be done so dynamically at run-time. The PLD I/O, Data Port, Address input, Peripheral I/O and MCU Reset modes are the only modes that must be defined before programming the device. All other modes can be changed by the MCU at run-time. See Application Note AN1171 for more detail.

Table 39 summarizes which modes are available on each port. Table 40 shows how and where the different modes are configured. Each of the port operating modes are described in the following sections.

Figure 26. General I/O port architecture

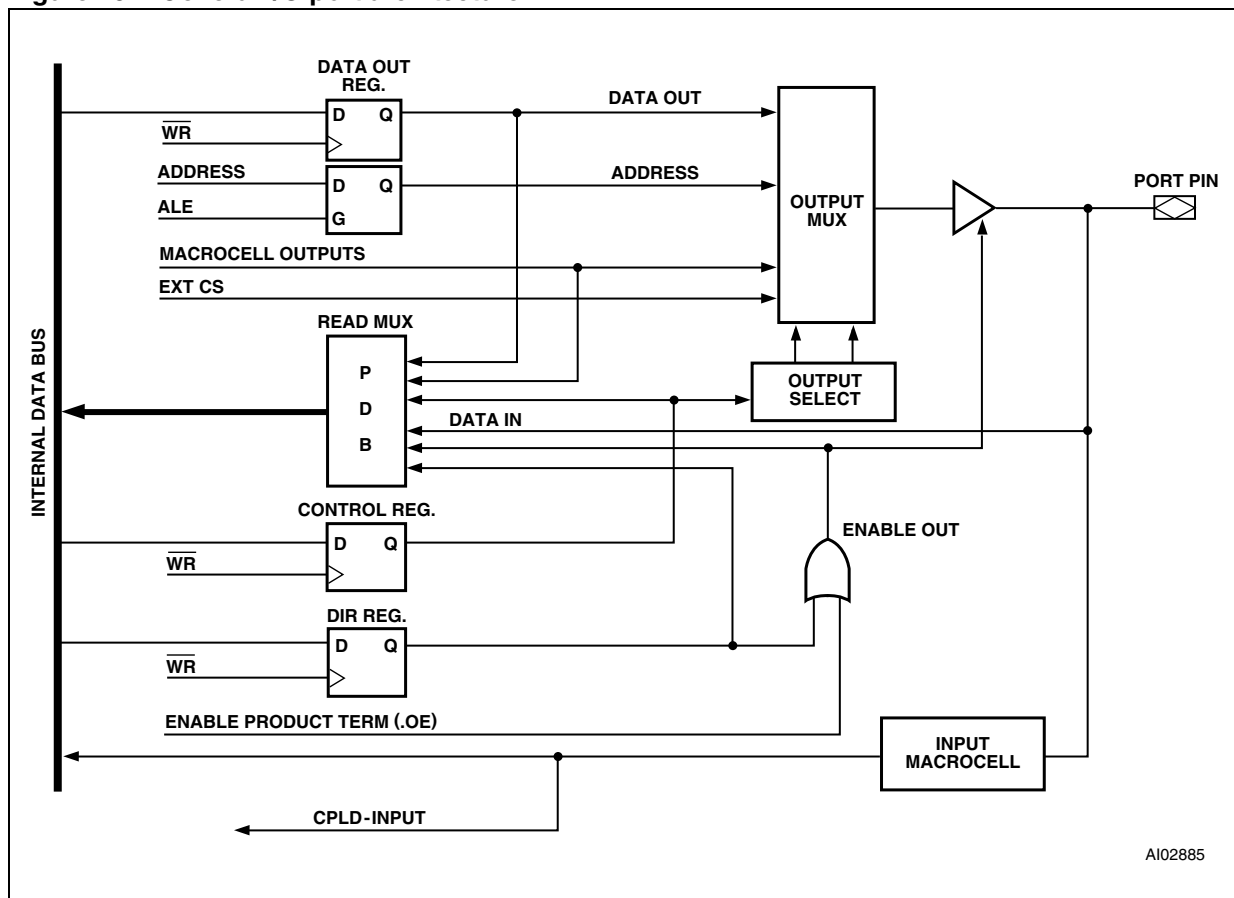

AI02885

20.3 MCU I/O mode

In the MCU I/O mode, the MCU uses the PSD Ports to expand its own I/O ports. By setting up the CSIOP space, the ports on the PSD are mapped into the MCU address space. The addresses of the ports are listed in [Table 6](#).

A port pin can be put into MCU I/O mode by writing a '0' to the corresponding bit in the Control register (for Ports E, F and G). The MCU I/O direction may be changed by writing to the corresponding bit in the Direction register, or by the output enable product term (see [Section 20.2: Port operating modes](#)). When the pin is configured as an output, the content of the Data Out register drives the pin. When configured as an input, the MCU can read the port input through the Data In buffer (see [Figure 26](#)).

Ports A, B and C do not have Control registers, and are in MCU I/O mode by default. They can be used for PLD I/O if they are specified in PSDsoft Express.

20.4 PLD I/O mode

The PLD I/O Mode uses a port as an input to the CPLD's input macrocells (IMC), and/or as an output from the CPLD's output macrocells (OMC). The output can be tri-stated with a control signal. This output enable control signal can be defined by a product term from the PLD, or by resetting the corresponding bit in the Direction register to '0'. The corresponding bit in the Direction register must not be set to '1' if the pin is defined for a PLD input signal in PSDsoft Express. The PLD I/O mode is specified in PSDsoft Express by declaring the port pins, and then specifying an equation in PSDsoft Express.

20.5 Address Out mode

For MCUs with a multiplexed address/data bus, Address Out mode can be used to drive latched addresses onto the port pins. These port pins can, in turn, drive external devices. Either the output enable or the corresponding bits of both the Direction register and Control register must be set to a '1' for pins to use Address Out mode. This must be done by the MCU at run-time. See [Table 41](#) for the address output pin assignments on Ports E, F and G for various MCUs.

Note: Do not drive address signals with Address Out Mode to an external memory device if it is intended for the MCU to Boot from the external device. The MCU must first Boot from PSD memory so the Direction and Control register bits can be set.

Table 39. Port operating modes

Port Mode	Port A	Port B	Port C	Port D	Port E	Port F	Port G
MCU I/O	Yes	Yes	Yes	Yes	Yes	Yes	Yes
PLD I/O							
McellA outputs	Yes	Yes	No	No	No	No	No
McellB outputs	No	Yes	No	No	No	No	No
Additional Ext. CS outputs	No	No	Yes	No	No	Yes	No
PLD inputs	Yes	Yes	Yes	Yes	No	Yes	No
Address Out	No	No	No	No	Yes (A7 - 0)	Yes (A7 - 0)	Yes (A7 - 0) or (A15 - 8)

Table 39. Port operating modes (continued)

Port Mode	Port A	Port B	Port C	Port D	Port E	Port F	Port G
Address In	Yes	Yes	Yes	Yes	No	Yes	No
Data Port	No	No	No	No	No	Yes	Yes
Peripheral I/O	Yes	No	No	Yes	No	Yes	No
JTAG ISP	No	No	No	No	Yes ⁽¹⁾	No	No
MCU Reset mode ⁽²⁾	No	No	No	No	No	Yes	Yes

1. Can be multiplexed with other I/O functions.
2. Available to Motorola 16-bit 683xx and HC16 families of MCUs.

Table 40. Port operating mode settings⁽¹⁾

Mode	Defined in PSDsoft Express	Control register setting	Direction register setting	VM register setting	JTAG Enable
MCU I/O	Declare pins only	0 ⁽²⁾	1 = output, 0 = input (3)	N/A	N/A
PLD I/O	Declare pins and Logic equations	N/A	(3)	N/A	N/A
Data Port (Port F, G)	Selected for MCU with non-multiplexed bus	N/A	N/A	N/A	N/A
Address Out (Port E, F, G)	Declare pins only	1	1 ⁽³⁾	N/A	N/A
Address In (Port A, B, C, D, F)	Declare pins or Logic equation for input macrocells	N/A	N/A	N/A	N/A
Peripheral I/O (Port F)	Logic equations (PSEL0 and PSEL1)	N/A	N/A	PIO bit = 1	N/A
JTAG ISP ⁽⁴⁾	Declare pins only	N/A	N/A	N/A	JTAG_Enable
MCU Reset mode	Specific pin logic level	N/A	N/A	N/A	N/A

1. N/A = Not Applicable
2. Control register setting is not applicable to Ports A, B and C.
3. The direction of the Port A,B,C, and F pins are controlled by the Direction register ORed with the individual output enable product term (.oe) from the CPLD AND Array.
4. Any of these three methods enables the JTAG pins on Port E.

Table 41. I/O port latched address output assignments⁽¹⁾

MCU	Port E (PE3-PE0)	Port E (PE7-PE4)	Port F (PF3-PF0)	Port F (PF7-PF4)	Port G (PG3-PG0)	Port G (PG7-PG4)
80C51XA	N/A	Address a7-a4	N/A	Address a7-a4	Address a11-a8	Address a15-a12
All other MCU with multiplexed bus	Address a3-a0	Address a7-a4	Address a3-a0	Address a7-a4	Address a11-a8	Address a15-a12

1. N/A = Not Applicable.

20.6 Address In mode

For MCUs that have more than 16 address signals, the higher addresses can be connected to Port A, B, C, D or F, and are routed as inputs to the PLDs. The address input can be latched in the input macrocell (IMC) by Address Strobe (ALE/AS, PD0). Any input that is included in the DPLD equations for the primary Flash memory, secondary Flash memory or SRAM is considered to be an address input.

20.7 Data Port mode

Ports F and G can be used as a data bus port for a MCU with a non-multiplexed address/data bus. The Data Port is connected to the data bus of the MCU. The general I/O functions are disabled in Ports F and G if the ports are configured as a Data Port. Data Port mode is automatically configured in PSDsoft Express when a non-multiplexed bus MCU is selected.

20.8 Peripheral I/O mode

Peripheral I/O mode can be used to interface with external 8-bit peripherals. In this mode, all of Port F serves as a tri-state, bi-directional data buffer for the MCU. Peripheral I/O mode is enabled by setting bit 7 of the VM register to a '1.' [Figure 27](#) shows how Port A acts as a bi-directional buffer for the MCU data bus if Peripheral I/O mode is enabled. An equation for PSEL0 and/or PSEL1 must be specified in PSDsoft Express. The buffer is tri-stated when PSEL0 or PSEL1 is not active.

Figure 27. Peripheral I/O mode

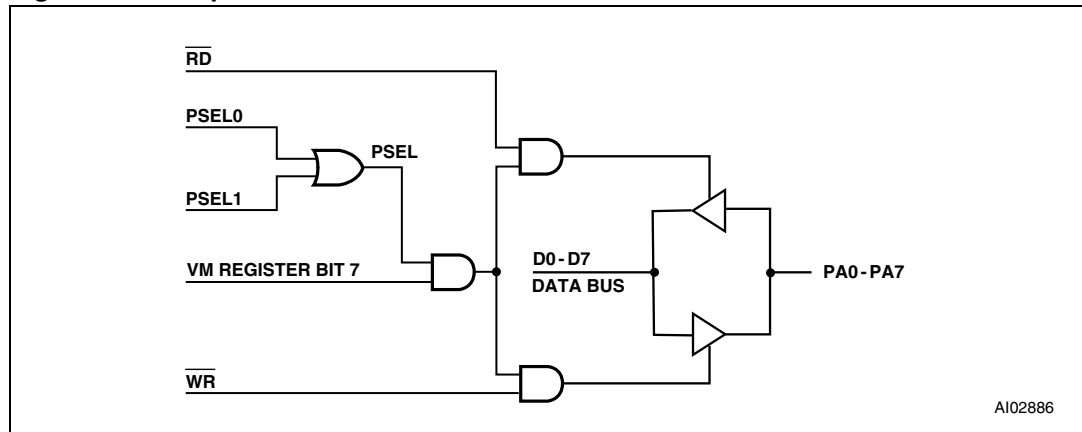

20.9 JTAG in-system programming (ISP)

Port E is JTAG compliant, and can be used for In-System Programming (ISP). You can multiplex JTAG operations with other functions on Port E because In-System Programming (ISP) is not performed during normal system operation. For more information on the JTAG Port, see [Figure 33: Reset \(RESET\) timing](#).

20.10 MCU Reset mode

Ports F and G can be configured to operate in MCU Reset mode. This mode is available when PSD is configured for the Motorola 16-bit 683xx and HC16 family and is active only during reset.

At the rising edge of the Reset input, the MCU reads the logic level on the data bus (D15-D0) pins. The MCU then configures some of its I/O pin functions according to the logic level input on the data bus lines. Two dedicated buffers are usually enabled during reset to drive the data bus lines to the desired logic level.

The PSD can replace the two buffers by configuring Ports F and G to operate in MCU Reset mode. In this mode, the PSD will drive the pre-defined logic level or data pattern on to the MCU data bus when Reset is active and there is no ongoing bus cycle. After reset, Ports F and G return to the normal Data Port mode.

The MCU Reset mode is enabled and configured in PSDsoft Express. The user defines the logic level (data pattern) that will be drive out from Ports F and G during reset.

20.11 Port Configuration registers (PCR)

Each Port has a set of Port Configuration registers (PCR) used for configuration. The contents of the registers can be accessed by the MCU through normal READ/WRITE bus cycles at the addresses given in [Table 6](#). The addresses in [Table 6](#) are the offsets in hexadecimal from the base of the CSIOP register.

The pins of a port are individually configurable and each bit in the register controls its respective pin. For example, bit 0 in a register refers to bit 0 of its port. The three Port Configuration registers (PCR), shown in [Table 42](#), are used for setting the Port configurations. The default Power-up state for each register in [Table 42](#) is 00h.

20.12 Control register

Any bit reset to '0' in the Control register sets the corresponding port pin to MCU I/O mode, and a '1' sets it to Address Out mode. The default mode is MCU I/O. Only Ports E, F and G have an associated Control register.

Table 42. Port Configuration registers (PCR)

Register name	Port	MCU access
Control	E, F, G	WRITE/READ
Direction	A, B, C, D, E, F, G	WRITE/READ
Drive Select ⁽¹⁾	A, B, C, D, E, F, G	WRITE/READ

1. See [Table 46](#) for Drive register bit definition.

20.13 Direction register

The Direction register controls the direction of data flow in the I/O Ports. Any bit set to '1' in the Direction register causes the corresponding pin to be an output, and any bit set to '0' causes it to be an input. The default mode for all port pins is input.

[Figure 28](#) and [Figure 30](#) show the Port Architecture diagrams for Ports A/B/C and E/F/G, respectively. The direction of data flow for Ports A, B, C and F are controlled not only by the direction register, but also by the output enable product term from the PLD AND Array. If the output enable product term is not active, the Direction register has sole control of a given pin's direction.

An example of a configuration for a Port with the three least significant bits set to output and the remainder set to input is shown in [Table 45](#). Since Port D only contains four pins, the Direction register for Port D has only the four least significant bits active.

Drive Select register

The Drive Select register configures the pin driver as Open Drain or CMOS for some port pins, and controls the slew rate for the other port pins. An external pull-up resistor should be used for pins configured as Open Drain.

A pin can be configured as Open Drain if its corresponding bit in the Drive Select register is set to a '1.' The default pin drive is CMOS.

(The slew rate is a measurement of the rise and fall times of an output. A higher slew rate means a faster output response and may create more electrical noise. A pin operates in a high slew rate when the corresponding bit in the Drive register is set to '1.' The default rate is slow slew.)

Table 46 shows the Drive register for Ports A, B, C, D, E, F and G. It summarizes which pins can be configured as Open Drain outputs and which pins the slew rate can be set for.

Table 43. Port Pin Direction Control, output Enable P.T. not defined

Direction register bit	Port pin mode
0	Input
1	Output

Table 44. Port Pin Direction Control, output Enable P.T. defined

Direction register bit	Output Enable P.T.	Port pin mode
0	0	Input
0	1	Output
1	0	Output
1	1	Output

Table 45. Port direction assignment example

Bit 7	Bit 6	Bit 5	Bit 4	Bit 3	Bit 2	Bit 1	Bit 0
0	0	0	0	0	1	1	1

Table 46. Drive register pin assignment⁽¹⁾

Drive register	Bit 7	Bit 6	Bit 5	Bit 4	Bit 3	Bit 2	Bit 1	Bit 0
Port A	Open Drain	Open Drain	Open Drain	Open Drain	Open Drain	Open Drain	Open Drain	Open Drain
Port B	Open Drain	Open Drain	Open Drain	Open Drain	Open Drain	Open Drain	Open Drain	Open Drain
Port C	Slew Rate	Slew Rate	Slew Rate	Slew Rate	Slew Rate	Slew Rate	Slew Rate	Slew Rate
Port D	NA	NA	NA	NA	Open Drain	Open Drain	Open Drain	Open Drain
Port E	Open Drain	Open Drain	Open Drain	Open Drain	Open Drain	Open Drain	Open Drain	Open Drain
Port F	Slew Rate	Slew Rate	Slew Rate	Slew Rate	Slew Rate	Slew Rate	Slew Rate	Slew Rate
Port G	Open Drain	Open Drain	Open Drain	Open Drain	Open Drain	Open Drain	Open Drain	Open Drain

1. NA = Not Applicable.

20.14 Port Data registers

The Port Data registers, shown in [Table 47](#), are used by the MCU to write data to or read data from the ports. [Table 47](#) shows the register name, the ports having each register type, and MCU access for each register type. The registers are described next.

20.15 Data In

Port pins are connected directly to the Data In buffer. In MCU I/O input mode, the pin input is read through the Data In buffer.

20.16 Data Out register

Stores output data written by the MCU in the MCU I/O output mode. The contents of the register are driven out to the pins if the Direction register or the output enable product term is set to '1.' The contents of the register can also be read back by the MCU.

20.17 Output macrocells (OMC)

The CPLD output macrocells (OMC) occupy a location in the MCU's address space. The MCU can read the output of the output macrocells (OMC). If the Mask macrocell register bits are not set, writing to the macrocell loads data to the macrocell flip-flops (see [Figure 13: Macrocell and I/O port](#)).

20.18 Mask macrocell register

Each Mask macrocell register bit corresponds to an output macrocell (OMC) flip-flop. When the Mask macrocell register bit is set to a '1,' loading data into the output macrocell (OMC) flip-flop is blocked. The default value is 0, or unblocked.

20.19 Input macrocells (IMC)

The input macrocells (IMC) can be used to latch or store external inputs. The outputs of the input macrocells (IMC) are routed to the PLD input bus, and can be read by the MCU (see [Section 18.6: Input macrocells \(IMC\)](#)).

Table 47. Port Data registers

Register Name	Port	MCU Access
Data In	A, B, C, D, E, F, G	READ - input on pin
Data Out	A, B, C, D, E, F, G	WRITE/READ
Output macrocell	A, B	READ - outputs of macrocells WRITE - loading macrocells Flip-flop

Table 47. Port Data registers

Register Name	Port	MCU Access
Mask macrocell	A, B	WRITE/READ - prevents loading into a given Macrocell
Input macrocell	A, B, C	READ - outputs of the input macrocells
Enable Out	A, B, C, F	READ - the output enable control of the port driver

20.20 Enable Out

The Enable Out register can be read by the MCU. It contains the output enable values for a given port. A '1' indicates the driver is in output mode. A '0' indicates the driver is in tri-state and the pin is in input mode.

20.21 Ports A, B and C - functionality and structure

Ports A, B and C have similar functionality and structure, as shown in [Figure 28](#). The ports can be configured to perform one or more of the following functions:

- MCU I/O mode
- CPLD output - macrocells McellA7-McellA0 can be connected to Port A. McellB7-McellB0 can be connected to Port B. External Chip Select (ECS7-ECS0) can be connected to Port C or Port F.
- CPLD input - Via the input macrocells (IMC).
- Address In - Additional high address inputs using the input macrocells (IMC).
- Open Drain/Slew Rate - pins PC7-PC0 can be configured to fast slew rate. Pins PA7-PA0 can be configured to Open Drain mode.

Figure 28. Port A, B and C structure

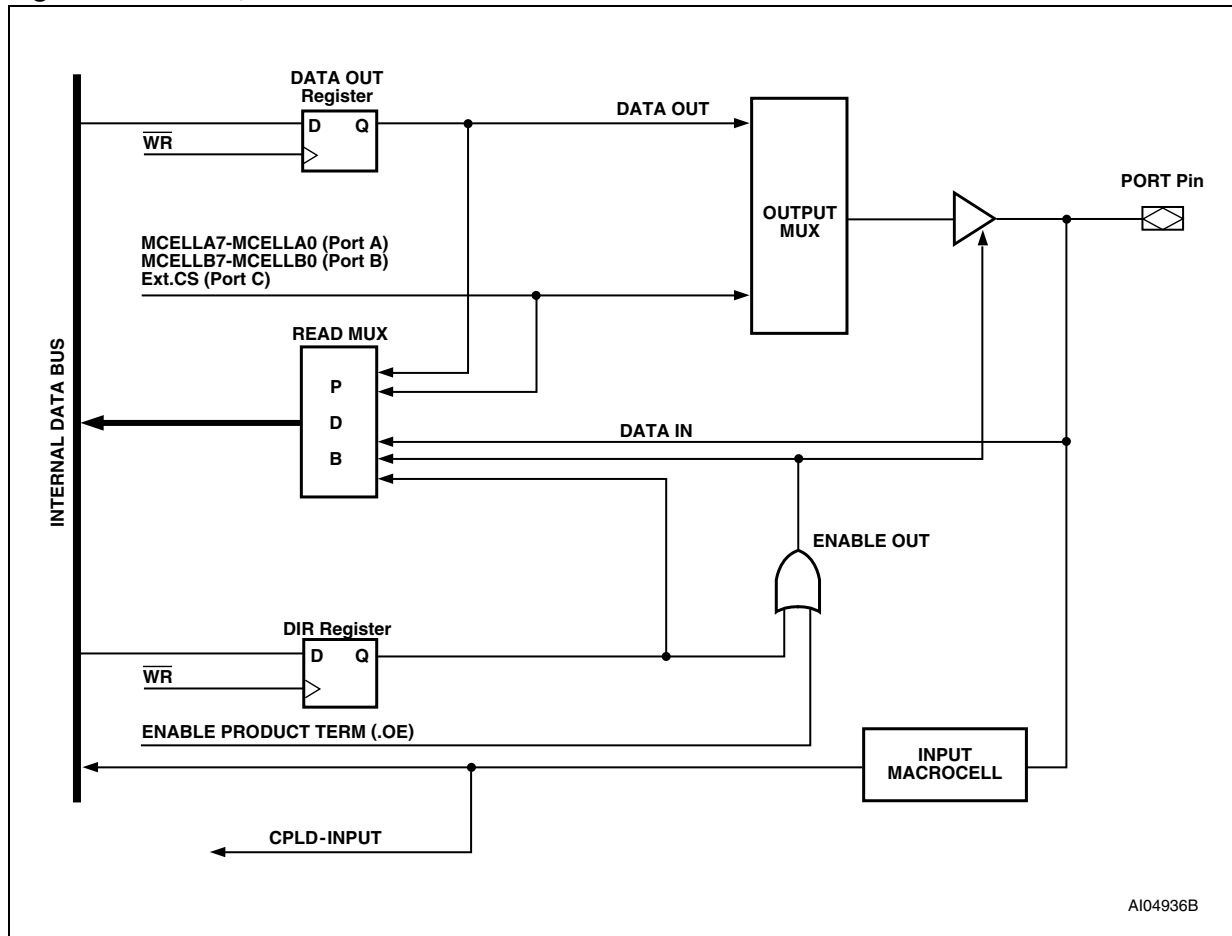

20.22 Port D - functionality and structure

Port D has four I/O pins. See [Figure 29](#). Port D can be configured to perform one or more of the following functions:

- MCU I/O mode
- CPLD input - direct input to the CPLD, no input macrocells (IMC)

Port D pins can be configured in PSDsoft Express as input pins for other dedicated functions:

- Address Strobe (ALE/AS, PD0)
- CLKIN (PD1) as input to the macrocells Flip-flops and APD counter
- PSD Chip Select input (\overline{CSI} , PD2). Driving this signal high disables the Flash memory, SRAM and CSIOP.
- Write Enable high-byte (\overline{WRH} , PD3) input, or as DBE input from a MC68HC912.

Figure 29. Port D structure

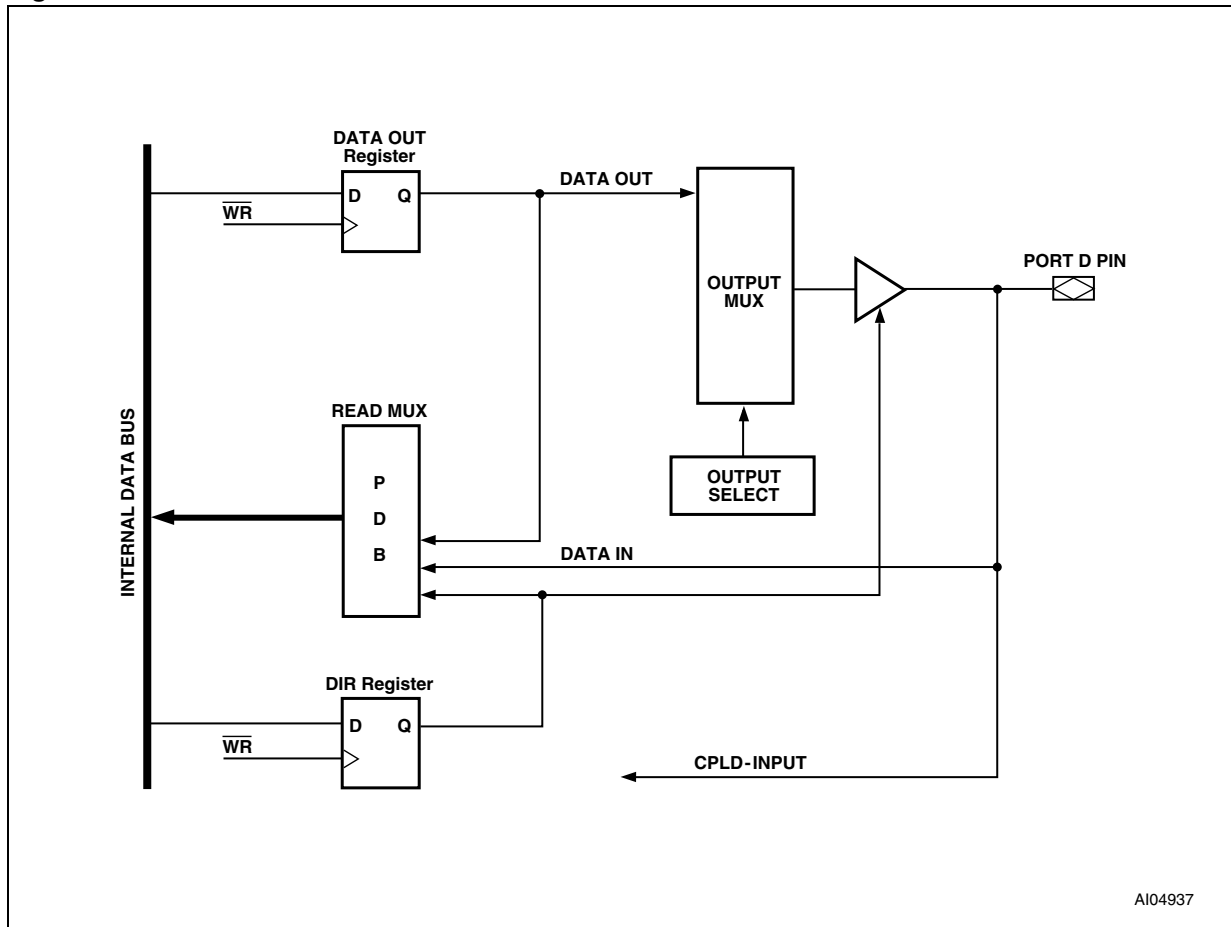

20.23 Port E - functionality and structure

Port E can be configured to perform one or more of the following functions (see [Figure 30](#)):

- MCU I/O Mode
- In-System Programming (ISP) - JTAG port can be enabled for programming/erase of the PSD device. See [Figure 33: Reset \(RESET\) timing](#) for more information on JTAG programming.
- Open Drain - pins can be configured in Open Drain Mode
- Latched Address output - Provide latched address output.

20.24 Port F - functionality and structure

Port F can be configured to perform one or more of the following functions:

- MCU I/O Mode
- CPLD output - External Chip Select (ECS7-ECS0) can be connected to Port F or Port C.
- CPLD input - direct input to the CPLD, no input macrocells (IMC)
- Latched Address output - Provide latched address output as per [Table 41](#).
- Slew Rate - pins can be configured for fast Slew Rate
- Data Port - connected to D7-D0 when Port F is configured as Data Port for a non-multiplexed bus
- Peripheral Mode
- MCU Reset Mode - for 16-bit Motorola 683xx and HC16 MCUs

20.25 Port G - functionality and structure

Port G can be configured to perform one or more of the following functions:

- MCU I/O Mode
- Latched Address output - Provide latched address output as per [Table 41](#).
- Open Drain - pins can be configured in Open Drain Mode
- Data Port - connected to D15-D8 when Port G is configured as Data Port for a non-multiplexed bus
- MCU Reset Mode - for 16-bit Motorola 683xx and hc16 mcus

Figure 30. Port E, F and G structure

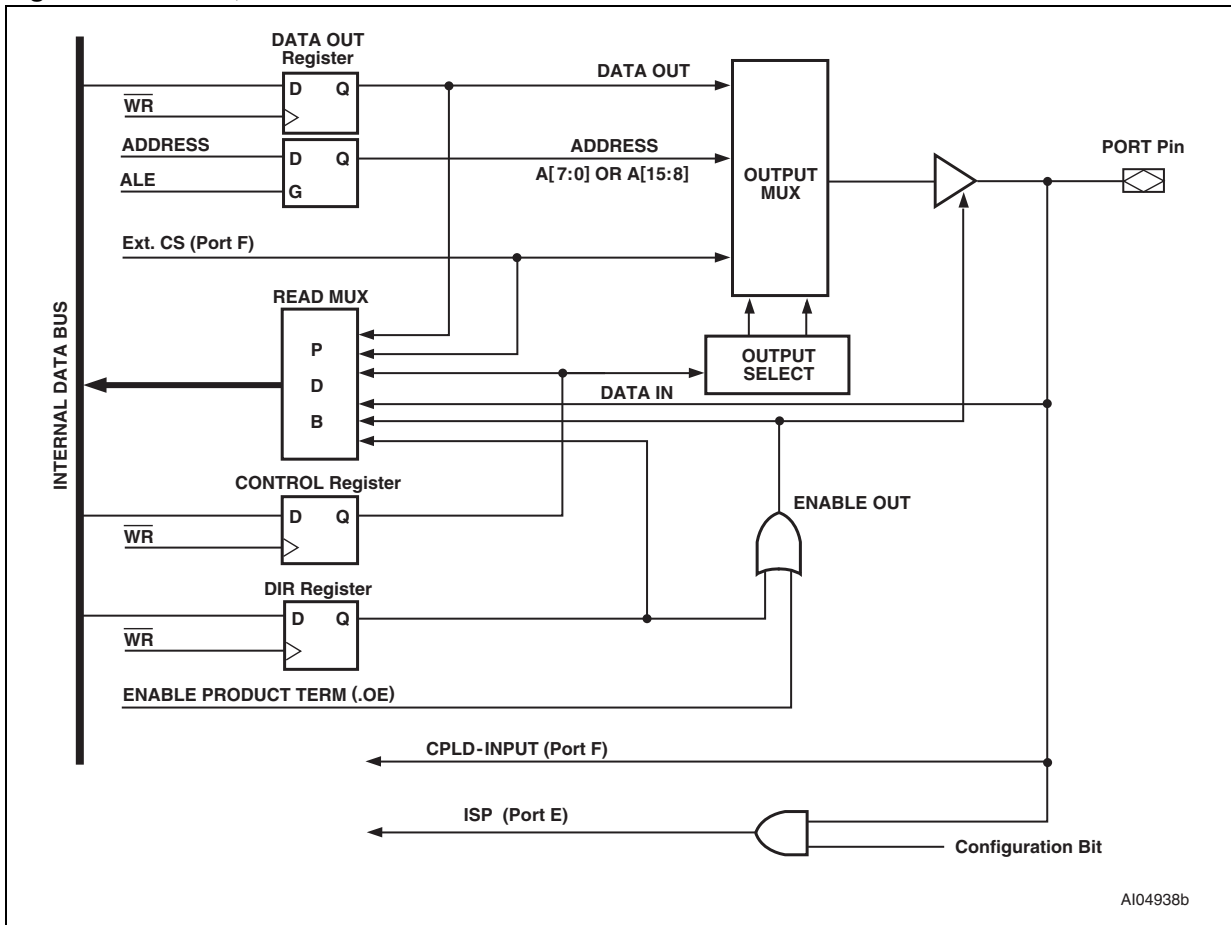

21 Power management

The PSD device offers configurable power saving options. These options may be used individually or in combinations, as follows:

- All memory blocks in a PSD (primary Flash memory, secondary Flash memory, and SRAM) are built with power management technology. In addition to using special silicon design methodology, power management technology puts the memories into standby mode when address/data inputs are not changing (zero DC current). As soon as a transition occurs on an input, the affected memory “wakes up”, changes and latches its outputs, then goes back to standby. The designer does *not* have to do anything special to achieve memory Standby mode when no inputs are changing—it happens automatically.

The PLD sections can also achieve Standby mode when its inputs are not changing, as described for the Power Management Mode registers (PMMR), later.

- The Automatic Power Down (APD) block allows the PSD to reduce to standby current automatically. The APD Unit also blocks MCU address/data signals from reaching the memories and PLDs. This feature is available on all PSD devices. The APD Unit is described in more detail in [Figure 31: APD unit](#).

Built in logic monitors the Address Strobe of the MCU for activity. If there is no activity for a certain period (the MCU is asleep), the APD Unit initiates Power-down mode (if enabled). Once in Power-down mode, all address/data signals are blocked from reaching the PSD memories and PLDs, and the memories are deselected internally. This allows the memories and PLDs to remain in Standby mode even if the address/data signals are changing state externally (noise, other devices on the MCU bus, etc.). Keep in mind that any unblocked PLD input signals that are changing states keeps the PLD out of Standby mode, but not the memories.

- PSD Chip Select input ($\overline{CS1}$, PD2) can be used to disable the internal memories, placing them in Standby mode even if inputs are changing. This feature does not block any internal signals or disable the PLDs. This is a good alternative to using the APD Unit, especially if your MCU has a chip select output. There is a slight penalty in memory access time when PSD Chip Select input ($\overline{CS1}$, PD2) makes its initial transition from deselected to selected.
- The Power Management Mode registers (PMMR) can be written by the MCU at run-time to manage power. All PSD devices support “blocking bits” in these registers that are set to block designated signals from reaching both PLDs. Current consumption of the PLDs is directly related to the composite frequency of the changes on their inputs (see [Figure 34](#)).

Significant power savings can be achieved by blocking signals that are not used in DPLD or CPLD logic equations at run-time. PSDsoft Express creates a fuse map that automatically blocks the low address byte ($A7-A0$) or the control signals (CNTL0-CNTL2, ALE and Write Enable high-byte (WRH/DBE , PD3)) if none of these signals are used in PLD logic equations.

PSD devices have a Turbo bit in PMMR0. This bit can be set to turn the Turbo mode off (the default is with Turbo mode turned on). While Turbo mode is off, the PLDs can achieve standby current when no PLD inputs are changing (zero DC current). Even when inputs do change, significant power can be saved at lower frequencies (AC current), compared to when Turbo mode is on. When the Turbo mode is on, there is a significant DC current component, and the AC component is higher.

21.1 Automatic Power-down (APD) Unit and Power-down mode

The APD Unit, shown in [Figure 31](#), puts the PSD into Power-down mode by monitoring the activity of Address Strobe (ALE/AS, PD0). If the APD Unit is enabled, as soon as activity on Address Strobe (ALE/AS, PD0) stops, a four-bit counter starts counting. If Address Strobe (ALE/AS, PD0) remains inactive for fifteen clock periods of CLKIN (PD1), Power-down (PDN) goes high, and the PSD enters Power-down mode, as discussed next.

21.2 Power-down mode

By default, if you enable the APD Unit, Power-down mode is automatically enabled. The device enters Power-down mode if Address Strobe (ALE/AS, PD0) remains inactive for fifteen periods of CLKIN (PD1).

The following should be kept in mind when the PSD is in Power-down mode:

- If Address Strobe (ALE/AS, PD0) starts pulsing again, the PSD returns to normal operation. The PSD also returns to normal operation if either PSD Chip Select input ($\overline{CS1}$, PD2) is low or the Reset (\overline{RESET}) input is high.
- The MCU address/data bus is blocked from all memory and PLDs.
- Various signals can be blocked (prior to Power-down mode) from entering the PLDs by setting the appropriate bits in the Power Management Mode registers (PMMR). The blocked signals include MCU control signals and the common CLKIN (PD1). Note that blocking CLKIN (PD1) from the PLDs does not block CLKIN (PD1) from the APD Unit.
- All PSD memories enter Standby mode and are drawing standby current. However, the PLDs and I/O ports blocks do *not* go into Standby mode because you do not want to have to wait for the logic and I/O to “wakeup” before their outputs can change. See [Table 48](#) for Power-down mode effects on PSD ports.
- Typical standby current is on the order of μA . This standby current value assumes that there are no transitions on any PLD input.

Table 48. Effect of Power-down mode on ports

Port function	Pin level
MCU I/O	No Change
PLD Out	No Change
Address Out	Undefined
Data port	Tri-State
Peripheral I/O	Tri-State

Figure 31. APD unit

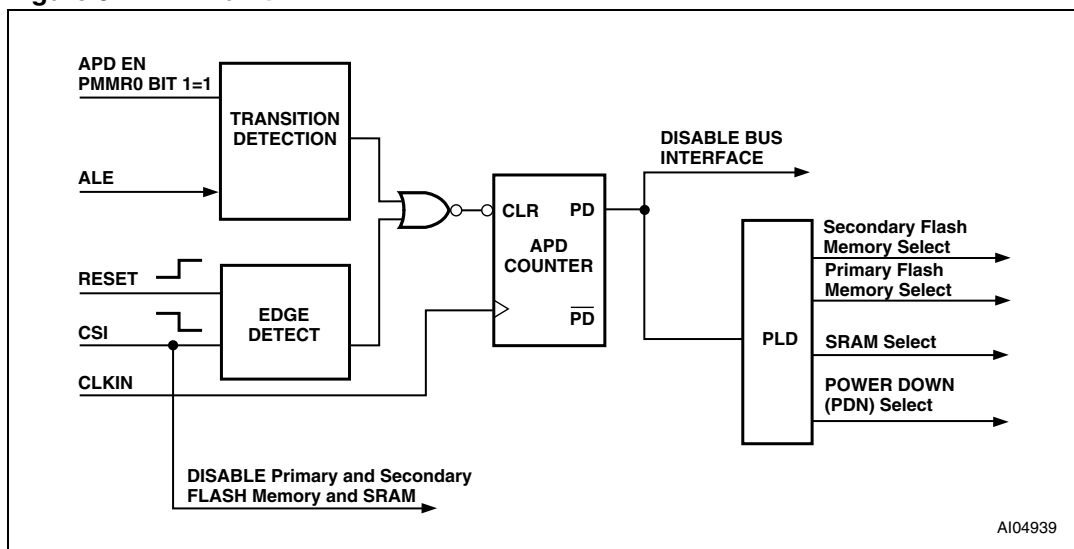

Table 49. PSD timing and standby current during Power-down mode⁽¹⁾

Mode	PLD propagation delay	Memory access time	Access recovery time to normal access	Typical standby current
Power-down	Normal t_{PD}	No Access	t_{LVDV}	I_{SB} ⁽²⁾

1. Power-down does not affect the operation of the PLD. The PLD operation in this mode is based only on the Turbo bit.
2. Typical current consumption, see [Table 61](#), assuming no PLD inputs are changing state and the PLD Turbo bit is 0.

21.3 Other power saving options

The PSD offers other reduced power saving options that are independent of the Power-down mode. Except for PSD Chip Select input (\overline{CSI} , PD2) features, they are enabled by setting bits in PMMR0 and PMMR2 (as summarized in [Section 6.15](#) and [Table 24](#)).

21.4 PLD power management

The power and speed of the PLDs are controlled by the Turbo bit (Bit 3) in PMMR0. By setting the bit to '1', the Turbo mode is off and the PLDs consume the specified standby current when the inputs are not switching for an extended time of 70 ns. The propagation delay time is increased after the Turbo bit is set to '1' (turned off) when the inputs change at a composite frequency of less than 15 MHz. When the Turbo bit is reset to '0' (turned on), the PLDs run at full power and speed. The Turbo bit affects the PLD's DC power, AC power, and propagation delay. See the AC and DC characteristics tables for PLD timing values (see [Table 69](#)).

Blocking MCU control signals with the PMMR2 bits can further reduce PLD AC power consumption.

21.5 PSD Chip Select input ($\overline{\text{CSI}}$, PD2)

PD2 of Port D can be configured in PSDsoft Express as PSD Chip Select input ($\overline{\text{CSI}}$). When low, the signal selects and enables the internal primary Flash memory, secondary Flash memory, SRAM, and I/O blocks for READ or WRITE operations involving the PSD. A high on PSD Chip Select input ($\overline{\text{CSI}}$, PD2) disables the primary Flash memory, secondary Flash memory, and SRAM, and reduces the PSD power consumption. However, the PLD and I/O signals remain operational when PSD Chip Select input ($\overline{\text{CSI}}$, PD2) is high.

There may be a timing penalty when using PSD Chip Select input ($\overline{\text{CSI}}$, PD2) depending on the speed grade of the PSD that you are using. See the timing parameter t_{SLQV} in [Table 69](#).

21.6 Input clock

The PSD provides the option to turn off CLKIN (PD1) to the PLD to save AC power consumption. CLKIN (PD1) is an input to the PLD AND Array and the output macrocells (OMC).

During Power-down mode, or, if CLKIN (PD1) is not being used as part of the PLD logic equation, the clock should be disabled to save AC power. CLKIN (PD1) is disconnected from the PLD AND Array or the macrocells block by setting bits 4 or 5 to a '1' in PMMR0.

Figure 32. Enable Power-down flowchart

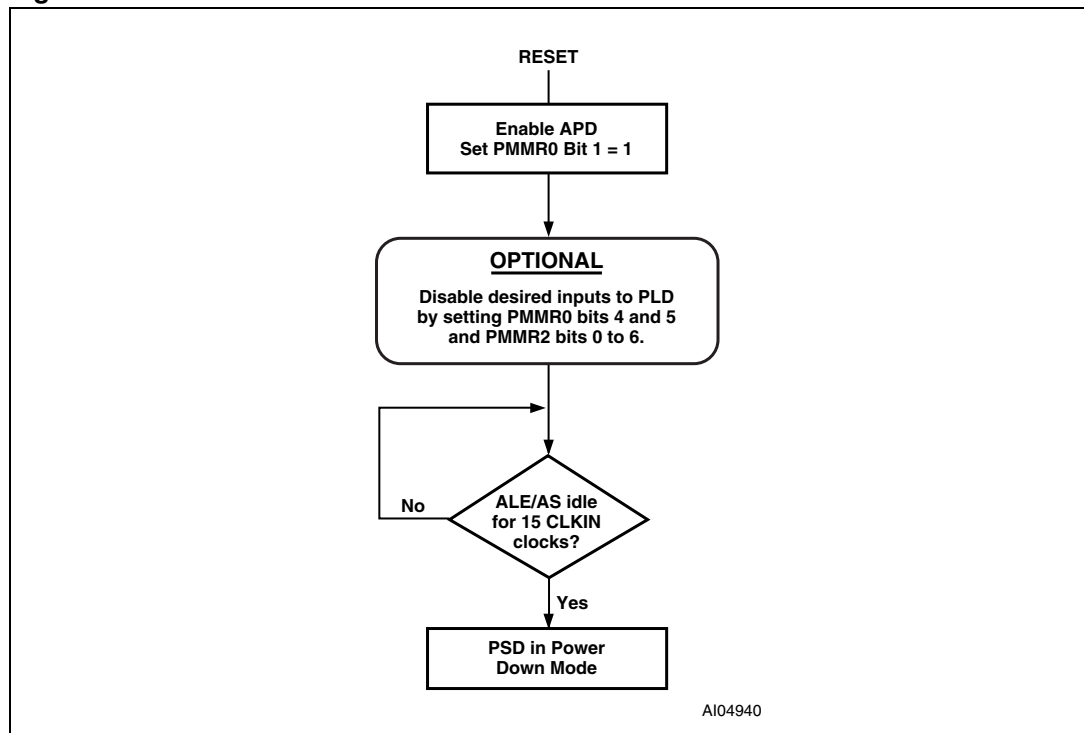

21.7 Input control signals

The PSD provides the option to turn off the address input (A7-A0) and input control signals (CNTL0, CNTL1, CNTL2, Address Strobe (ALE/AS, PD0) and Write Enable high-byte (WRH/DBE, PD3)) to the PLD to save AC power consumption. These signals are inputs to the PLD AND Array. During Power-down mode, or, if any of them are not being used as part of the PLD logic equation, these control signals should be disabled to save AC power. They are disconnected from the PLD AND Array by setting bits 0, 2, 3, 4, 5 and 6 to a '1' in PMMR2.

Table 50. APD counter operation

APD Enable bit	ALE PD polarity	ALE level	APD counter
0	X	X	Not counting
1	X	Pulsing	Not counting
1	1	1	Counting (Generates PDN after 15 clocks)
1	0	0	Counting (Generates PDN after 15 clocks)

22 Power-on Reset, Warm Reset and Power-down

22.1 Power-on Reset

Upon Power-up, the PSD requires a Reset ($\overline{\text{RESET}}$) pulse of duration $t_{\text{NLNH-PO}}$ (minimum 1 ms) after V_{CC} is steady. During this period, the device loads internal configurations, clears some of the registers and sets the Flash memory into Operating mode. After the rising edge of Reset ($\overline{\text{RESET}}$), the PSD remains in the Reset mode for an additional period, t_{OPR} (maximum 120 ns), before the first memory access is allowed.

The PSD Flash memory is reset to the READ mode upon Power-up. Sector Select (FS0-FS7 and CSBOOT0-CSBOOT3) must all be low, Write Strobe ($\overline{\text{WR/WRL}}$, CNTL0) high, during Power-on Reset for maximum security of the data contents and to remove the possibility of data being written on the first edge of Write Strobe ($\overline{\text{WR/WRL}}$, CNTL0). Any Flash memory WRITE cycle initiation is prevented automatically when V_{CC} is below V_{LKO} .

22.2 Warm Reset

Once the device is up and running, the device can be reset with a pulse of a much shorter duration, t_{NLNH} (minimum 150 ns). The same t_{OPR} period is needed before the device is operational after warm reset. [Figure 33](#) shows the timing of the Power-up and warm reset.

22.3 I/O pin, register and PLD status at Reset

[Table 51](#) shows the I/O pin, register and PLD status during Power-on reset, warm reset and Power-down mode. PLD outputs are always valid during warm reset, and they are valid in Power-on Reset once the internal PSD Configuration bits are loaded. This loading of PSD is completed typically long before the V_{CC} ramps up to operating level. Once the PLD is active, the state of the outputs are determined by equations specified in PSDsoft Express.

22.4 Reset of Flash Memory Erase and Program cycles

An external Reset ($\overline{\text{RESET}}$) also resets the internal Flash memory state machine. During a Flash memory Program or Erase cycle, Reset ($\overline{\text{RESET}}$) terminates the cycle and returns the Flash memory to the READ mode within a period of $t_{\text{NLNH-A}}$ (minimum 25 μs).

Table 51. Status During Power-On Reset, Warm Reset and Power-down mode

Port configuration	Power-On Reset	Warm Reset	Power-down mode
MCU I/O	Input mode	Input mode	Unchanged
PLD output	Valid after internal PSD configuration bits are loaded	Valid	Depends on inputs to PLD (addresses are blocked in PD mode)
Address Out	Tri-stated	Tri-stated	Not defined
Data Port	Tri-stated	Tri-stated	Tri-stated
Peripheral I/O	Tri-stated	Tri-stated	Tri-stated
PMMR0 and PMMR2	Cleared to '0'	Unchanged	Unchanged

Table 51. Status During Power-On Reset, Warm Reset and Power-down mode (continued)

Port configuration	Power-On Reset	Warm Reset	Power-down mode
Macrocells Flip-flop status	Cleared to '0' by internal Power-On Reset	Depends on .re and .pr equations	Depends on .re and .pr equations
VM register ⁽¹⁾	Initialized, based on the selection in PSDsoft Express Configuration menu	Initialized, based on the selection in PSDsoft Express Configuration menu	Unchanged
All other registers	Cleared to '0'	Cleared to '0'	Unchanged

1. The SR_code and Peripheral Mode bits in the VM register are always cleared to '0' on Power-On Reset or Warm Reset.

Figure 33. Reset ($\overline{\text{RESET}}$) timing

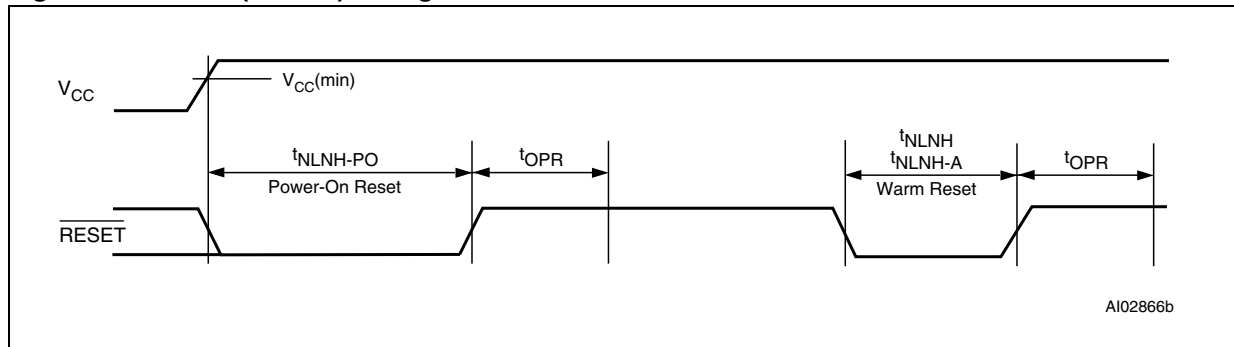

23 Programming in-circuit using the JTAG serial interface

The JTAG Serial Interface on the PSD can be enabled on Port E (see [Table 52](#)). All memory blocks (primary Flash memory and secondary Flash memory), PLD logic, and PSD Configuration bits may be programmed through the JTAG-ISC Serial Interface. A blank device can be mounted on a printed circuit board and programmed using JTAG In-System Programming (ISP).

The standard JTAG signals (IEEE 1149.1) are TMS, TCK, TDI, and TDO. Two additional signals, TSTAT and $\overline{\text{TERR}}$, are optional JTAG extensions used to speed up Program and Erase cycles.

Note: By default, on a blank PSD (as shipped from the factory, or after erasure), four pins on Port E are enabled for the basic JTAG signals TMS, TCK, TDI, and TDO.

See Application Note AN1153 for more details on JTAG In-System Programming (ISP).

23.1 Standard JTAG signals

The standard JTAG signals (TMS, TCK, TDI, and TDO) can be enabled by any of three different conditions that are logically ORed. When enabled, TDI, TDO, TCK, and TMS are inputs, waiting for a serial command from an external JTAG controller device (such as FlashLINK or Automated Test Equipment). When the enabling command is received from the external JTAG controller device, TDO becomes an output and the JTAG channel is fully functional inside the PSD. The same command that enables the JTAG channel may optionally enable the two additional JTAG pins, TSTAT and $\overline{\text{TERR}}$.

The following symbolic logic equation specifies the conditions enabling the four basic JTAG pins (TMS, TCK, TDI, and TDO) on their respective Port E pins. For purposes of discussion, the logic label JTAG_ON is used. When JTAG_ON is true, the four pins are enabled for JTAG. When JTAG_ON is false, the four pins can be used for general PSD I/O.

```
JTAG_ON = PSDsoft Express_enabled +
/* An NVM configuration bit inside the PSD is set by the designer
in the PSDsoft Express Configuration utility. This dedicates the
pins for JTAG at all times (compliant with IEEE 1149.1 */
Microcontroller_enabled +
/* The microcontroller can set a bit at run-time by writing to the
PSD register, JTAG Enable. This register is located at address CSIOp
+ offset C7h. Setting the JTAG_ENABLE bit in this register will
enable the pins for JTAG use. This bit is cleared by a PSD reset or
the microcontroller. See Table 21 for bit definition. */
PSD_product_term_enabled;
/* A dedicated product term (PT) inside the PSD can be used to
enable the JTAG pins. This PT has the reserved name JTAGSEL. Once
defined as a node in PSDlabel, the designer can write an equation for
JTAGSEL. This method is used when the Port E JTAG pins are
multiplexed with other I/O signals. It is recommended to tie
logically the node JTAGSEL to the JEN\ signal on the Flashlink cable
when multiplexing JTAG signals. See Application Note 1153 for
details. */
```

The state of the PSD Reset ($\overline{\text{RESET}}$) signal does not interrupt (or prevent) JTAG operations if the JTAG pins are dedicated by an NVM configuration bit (via PSDsoft Express). However, Reset ($\overline{\text{RESET}}$) will prevent or interrupt JTAG operations if the JTAG Enable register (as shown in [Table 21](#)) is used to enable the JTAG pins.

The PSD supports JTAG In-System-Programmability (ISP) commands, but not Boundary Scan. ST's PSDsoft Express software tool and FlashLINK JTAG programming cable implement the JTAG In-System-Programmability (ISP) commands.

23.2 JTAG extensions

TSTAT and $\overline{\text{TERR}}$ are two JTAG extension signals enabled by a JTAG command received over the four standard JTAG pins (TMS, TCK, TDI, and TDO). They are used to speed Program and Erase cycles by indicating status on PSD pins instead of having to scan the status out serially using the standard JTAG channel. See Application Note [AN1153](#).

$\overline{\text{TERR}}$ indicates if an error has occurred when erasing a sector or programming in Flash memory. This signal goes low (active) when an Error condition occurs, and stays low until a specific JTAG command is executed or a Reset ($\overline{\text{RESET}}$) pulse is received after an "ISC_DISABLE" command.

TSTAT behaves the same as Ready/Busy (PE4) described in [Section 7.2.2: Ready/Busy \(PE4\)](#). TSTAT is high when the PSD4235G2 device is in READ mode (primary Flash memory and secondary Flash memory contents can be read). TSTAT is low when Flash memory Program or Erase cycles are in progress, and also when data is being written to the secondary Flash memory .

TSTAT and $\overline{\text{TERR}}$ can be configured as open-drain type signals with a JTAG command.

Note: *The state of Reset ($\overline{\text{Reset}}$) does not interrupt (or prevent) JTAG operations if the JTAG signals are dedicated by an NVM Configuration bit (via PSDsoft Express). However, Reset ($\overline{\text{Reset}}$) prevents or interrupts JTAG operations if the JTAG Enable register (as shown in [Table 21](#)) is used to enable the JTAG signals.*

23.3 Security and Flash memory protection

When the Security bit is set, the device cannot be read on a device programmer or through the JTAG Port. When using the JTAG Port, only a Full Chip Erase command is allowed.

All other Program, Erase and Verify commands are blocked. Full Chip Erase returns the device to a non-secured blank state. The Security bit can be set in PSDsoft Express.

All primary Flash memory and secondary Flash memory sectors can individually be sector protected against erasure. The sector protect bits can be set in PSDsoft Express.

Table 52. JTAG port signals

Port E pin	JTAG signals	Description
PE0	TMS	Mode Select
PE1	TCK	Clock
PE2	TDI	Serial Data In
PE3	TDO	Serial Data Out

Table 52. JTAG port signals (continued)

Port E pin	JTAG signals	Description
PE4	TSTAT	Status
PE5	TERR	Error Flag

24 Initial delivery state

When delivered from ST, the PSD device has all bits in the memory and PLDs set to '1.' The PSD Configuration register bits are set to '0.' The code, configuration, and PLD logic are loaded using the programming procedure. Information for programming the device is available directly from ST. Please contact your local sales representative.

25 Maximum rating

Stressing the device above the rating listed in the Absolute Maximum Ratings" table may cause permanent damage to the device. These are stress ratings only and operation of the device at these or any other conditions above those indicated in the Operating sections of this specification is not implied. Exposure to Absolute Maximum Rating conditions for extended periods may affect device reliability. Refer also to the STMicroelectronics SURE Program and other relevant quality documents.

Table 53. Absolute maximum ratings

Symbol	Parameter	Min.	Max.	Unit
T _{STG}	Storage temperature	-65	125	°C
T _{LEAD}	Lead temperature during Soldering (20 seconds max.) ⁽¹⁾		235	°C
V _{IO}	Input and output voltage (Q = V _{OH} or Hi-Z)	-0.6	7.0	V
V _{CC}	Supply voltage	-0.6	7.0	V
V _{PP}	Device programmer supply voltage	-0.6	14.0	V
V _{ESD}	Electrostatic discharge voltage (Human Body model) ⁽²⁾	-2000	2000	V

1. IPC/JEDEC J-STD-020A

2. JEDEC Std JESD22-A114A (C1=100 pF, R1=1500 Ω, R2=500 Ω)

26 DC and AC parameters

These tables describe the AD and DC parameters of the PSD4235G2:

- DC Electrical Specification
- AC timing Specification
 - PLD timing
 - Combinatorial timing
 - Synchronous clock mode
 - Asynchronous clock mode
 - Input macrocell timing
 - MCU timing
 - READ timing
 - WRITE timing
 - Peripheral mode timing
 - Power-down and Reset timing

The parameters in the DC and AC Characteristic tables that follow are derived from tests performed under the Measurement Conditions summarized in the relevant tables. Designers should check that the operating conditions in their circuit match the measurement conditions when relying on the quoted parameters.

The following are issues concerning the parameters presented:

- In the DC specification the supply current is given for different modes of operation. Before calculating the total power consumption, determine the percentage of time that the PSD is in each mode. Also, the supply power is considerably different if the Turbo bit is 0.
- The AC power component gives the PLD, Flash memory, and SRAM mA/MHz specification. *Figure 34* show the PLD mA/MHz as a function of the number of Product Terms (PT) used.
- In the PLD timing parameters, add the required delay when Turbo bit is 0.

Figure 34. PLD I_{CC} /frequency consumption

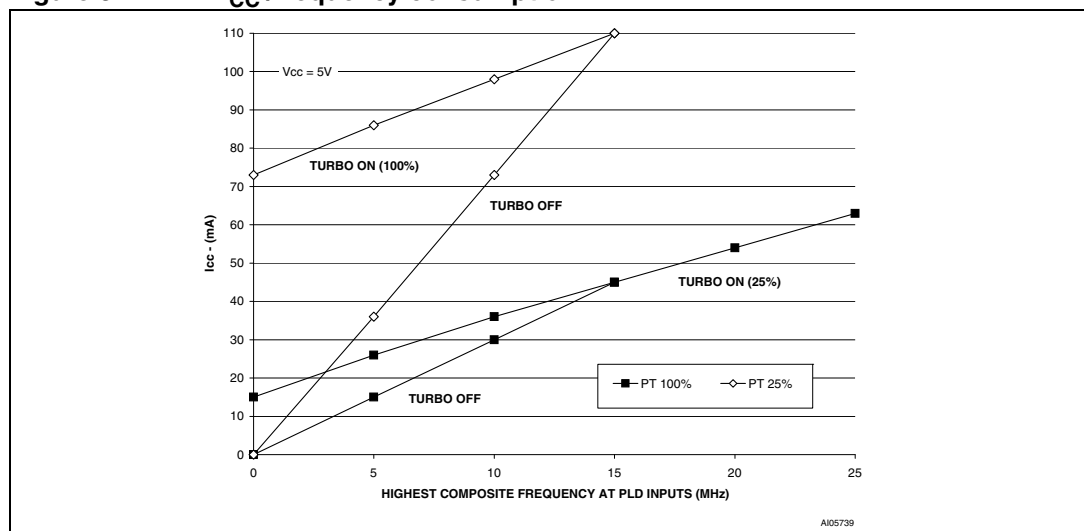

Table 54. Example of PSD typical power calculation at V_{CC} = 5.0V (with Turbo mode on)⁽¹⁾

Conditions		
Highest Composite PLD input frequency		
	(Freq PLD)	= 8 MHz
MCU ALE frequency (Freq ALE)		= 4 MHz
	% Flash memory Access	= 80%
	% SRAM access	= 15%
	% I/O access	= 5% (no additional power above base)
Operational Modes		
	% Normal	= 10%
	% Power-down mode	= 90%
Number of product terms used		
	(from fitter report)	= 45 PT
	% of total product terms	= 45/193 = 23.3%
	Turbo Mode	= ON
Calculation (using typical values)		
I _{CC} total	= I _{pwrdown} x %pwrdown + %normal x (I _{CC} (ac) + I _{CC} (dc))	
	= I _{pwrdown} x %pwrdown + % normal x (%flash x 2.5 mA/MHz x Freq ALE	
		+ %SRAM x 1.5 mA/MHz x Freq ALE
		+ % PLD x 2 mA/MHz x Freq PLD
		+ #PT x 400µA/PT)
	= 50µA x 0.90 + 0.1 x (0.8 x 2.5 mA/MHz x 4 MHz	
		+ 0.15 x 1.5 mA/MHz x 4 MHz
		+ 2 mA/MHz x 8 MHz
		+ 45 x 0.4 mA/PT)
	= 45µA + 0.1 x (8 + 0.9 + 16 + 18 mA)	
	= 45µA + 0.1 x 42.9	
	= 45µA + 4.29 mA	
	= 4.34 mA	

1. This is the operating power with no Flash memory Program or Erase cycles in progress. Calculation is based on I_{OUT}=0 mA.

Table 55. Example of PSD typical power calculation at V_{CC} = 5.0V (with Turbo mode off)⁽¹⁾

Conditions		
Highest Composite PLD input frequency		
	(Freq PLD)	= 8 MHz
	MCU ALE frequency (Freq ALE)	= 4 MHz
	% Flash memory Access	= 80%
	% SRAM access	= 15%
	% I/O access	= 5% (no additional power above base)
Operational modes		
	% Normal	= 10%
	% Power-down Mode	= 90%
Number of product terms used		
	(from fitter report)	= 45 PT
	% of total product terms	= 45/193 = 23.3%
	Turbo Mode	= Off
Calculation (using typical values)		
I _{CC} total	= I _{pwrdn} x %pwrdown + %normal x (I _{CC} (ac) + I _{CC} (dc))	
	= I _{pwrdn} x %pwrdown + % normal x (%flash x 2.5 mA/MHz x Freq ALE	
		+ %SRAM x 1.5 mA/MHz x Freq ALE
		+ % PLD x (from graph using Freq PLD))
	= 50µA x 0.90 + 0.1 x (0.8 x 2.5 mA/MHz x 4 MHz	
		+ 0.15 x 1.5 mA/MHz x 4 MHz
		+ 24 mA)
	= 45µA + 0.1 x (8 + 0.9 + 24)	
	= 45µA + 0.1 x 32.9	
	= 45µA + 3.29 mA	
	= 3.34 mA	

1. This is the operating power with no Flash memory Program or Erase cycles in progress. Calculation is based on I_{OUT} = 0 mA.

Table 56. Operating conditions

Symbol	Parameter	Min.	Max.	Unit
V_{CC}	Supply voltage	4.5	5.5	V
T_A	Ambient operating temperature (industrial)	-40	85	°C
	Ambient operating temperature (commercial)	0	70	°C

Table 57. AC signal letters for PLD timings⁽¹⁾

Letter	Description
A	Address input
C	CEout output
D	Input data
E	E input
G	Internal WDOG_ON signal
I	Interrupt input
L	ALE input
N	Reset input or output
P	Port signal output
Q	Output data
R	\overline{WR} , \overline{UDS} , \overline{LDS} , \overline{DS} , \overline{IORD} , \overline{PSEN} inputs
S	Chip Select input
T	R/\overline{W} input
W	Internal PDN Signal
B	V_{STBY} output
M	Output macrocell

1. Example: t_{AVLX} = time from Address Valid to ALE Invalid.

Table 58. AC signal behavior symbols for PLD timings

Letter	Description
t	Time
L	Logic level low or ALE
H	Logic level high
V	Valid
X	No Longer a Valid Logic level
Z	Float

Table 59. AC measurement conditions⁽¹⁾

Symbol	Parameter	Min.	Max.	Unit
C_L	Load Capacitance	30		pF

1. Output Hi-Z is defined as the point where data out is no longer driven.

Table 60. Capacitance⁽¹⁾

Symbol	Parameter	Test condition	Typ ⁽²⁾	Max.	Unit
C_{IN}	Input capacitance (for input pins)	$V_{IN} = 0V$	4	6	pF
C_{OUT}	Output capacitance (for input/output pins)	$V_{OUT} = 0V$	8	12	pF
C_{VPP}	Capacitance (for CNTL2/ V_{PP})	$V_{PP} = 0V$	18	25	pF

1. Sampled only, not 100% tested.
2. Typical values are for $T_A = 25^\circ C$ and nominal supply voltages.

Figure 35. AC measurement I/O waveform

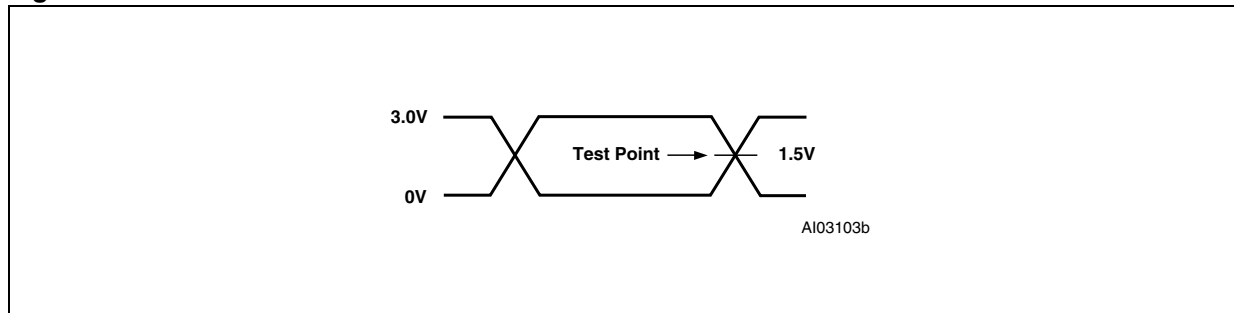

Figure 36. AC measurement load circuit

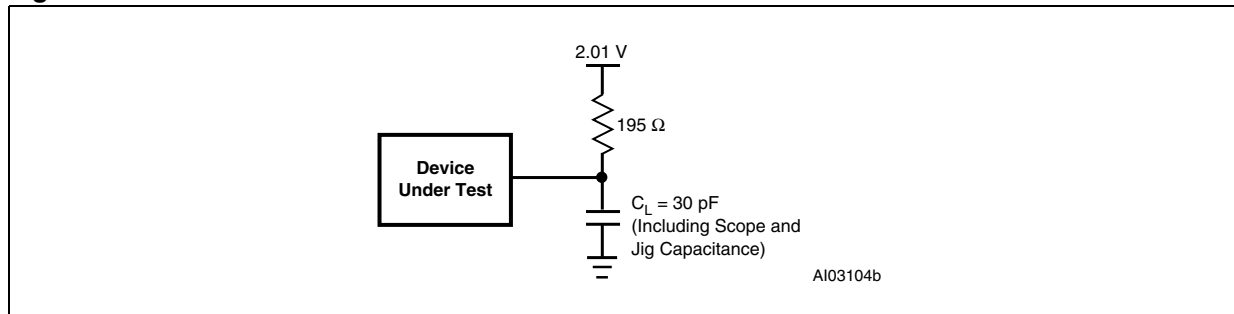

Figure 37. Switching waveforms - key

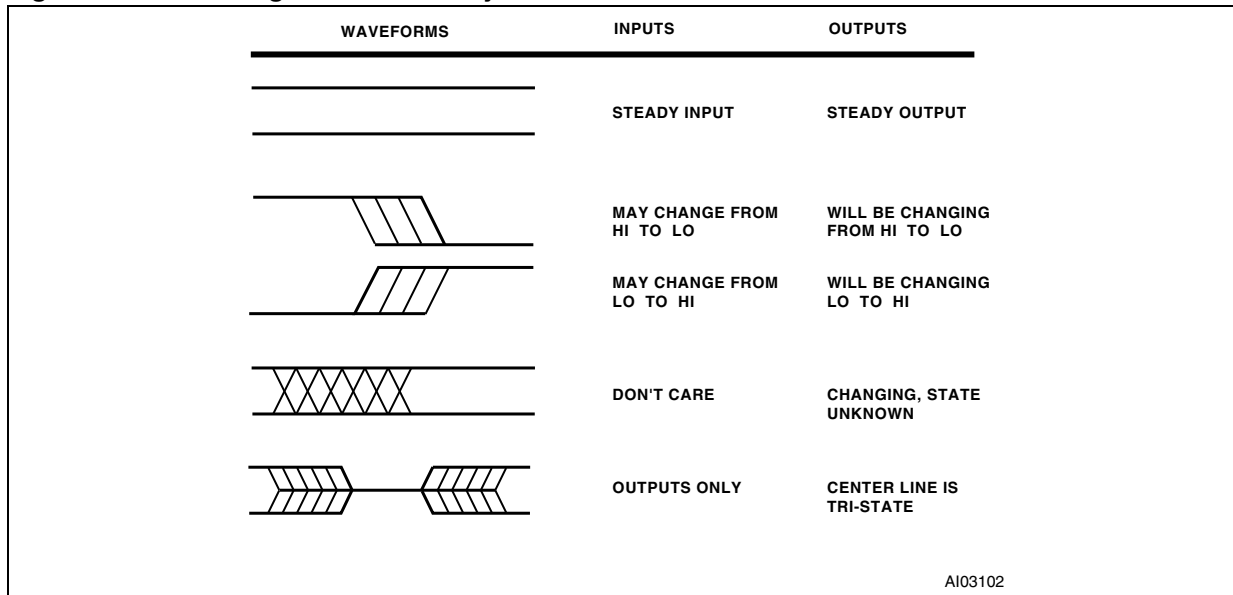

Table 61. DC characteristics

Symbol	Parameter	Test Condition (in addition to those in Table 56)	Min.	Typ.	Max.	Unit
V _{IH}	input high voltage	4.5V < V _{CC} < 5.5V	2		V _{CC} +0.5	V
V _{IL}	input low voltage	4.5V < V _{CC} < 5.5V	-0.5		0.8	V
V _{IH1}	RESET high level input voltage	(1)	0.8V _{CC}		V _{CC} +0.5	V
V _{IL1}	RESET low level input voltage	(1)	-0.5		0.2V _{CC} -0.1	V
V _{HYS}	RESET pin hysteresis		0.3			V
V _{LKO}	V _{CC} (min) for Flash Erase and Program		2.5		4.2	V
V _{OL}	Output low voltage	I _{OL} = 20 μA, V _{CC} = 4.5V		0.01	0.1	V
		I _{OL} = 8 mA, V _{CC} = 4.5V		0.25	0.45	V
V _{OH}	Output high voltage	I _{OH} = -20μA, V _{CC} = 4.5V	4.4	4.49		V
		I _{OH} = -2 mA, V _{CC} = 4.5V	2.4	3.9		V
I _{SB}	Standby supply current for Power-down mode	$\overline{CS1} > V_{CC} - 0.3V^{(2)(3)}$		100	200	μA
I _{LI}	input Leakage Current	V _{SS} < V _{IN} < V _{CC}	-1	±0.1	1	μA
I _{LO}	output Leakage Current	0.45 < V _{OUT} < V _{CC}	-10	±5	10	μA

Table 61. DC characteristics (continued)

Symbol	Parameter		Test Condition (in addition to those in Table 56)	Min.	Typ.	Max.	Unit
I _{CC} (DC) (Note 5)	Operating Supply Current	PLD Only	PLD_TURBO = Off, f = 0 MHz (Note 5)		0		μA/PT
			PLD_TURBO = On, f = 0 MHz		400	700	μA/PT
		Flash memory	During Flash memory WRITE/Erase Only		15	30	mA
			Read Only, f = 0 MHz		0	0	mA
		SRAM	f = 0 MHz		0	0	mA
I _{CC} (AC)	PLD AC Adder					(4)	
	Flash memory AC Adder				2.5	3.5	mA/ MHz
	SRAM AC Adder				1.5	3.0	mA/ MHz

1. Reset (RESET) has hysteresis. V_{IL1} is valid at or below 0.2V_{CC} - 0.1. V_{IH1} is valid at or above 0.8V_{CC}.
2. CS̄ is deselected or internal Power-down mode is active.
3. PLD is in non-Turbo mode, and none of the inputs are switching.
4. Please see Figure 34 for the PLD current calculation.

Figure 38. Input to output Disable/Enable

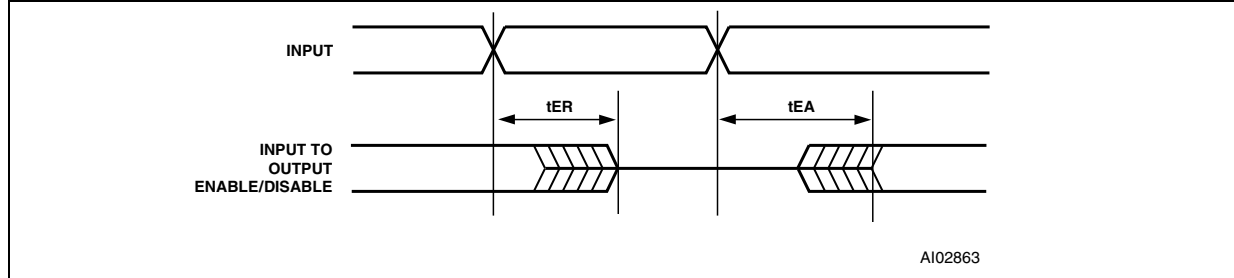

Table 62. CPLD Combinatorial timing

Symbol	Parameter	Conditions	-70		-90		Fast PT Aloc	Turbo Off	Slew rate (1)	Unit
			Min	Max	Min	Max				
t _{PD}	CPLD input Pin/Feedback to CPLD Combinatorial output			20		25	+ 2	+ 12	- 2	ns
t _{EA}	CPLD input to CPLD output Enable			21		26		+ 12	- 2	ns
t _{ER}	CPLD input to CPLD output Disable			21		26		+ 12	- 2	ns
t _{ARP}	CPLD register Clear or Preset Delay			21		26		+ 12	- 2	ns

Table 62. CPLD Combinatorial timing (continued)

Symbol	Parameter	Conditions	-70		-90		Fast PT Alloc	Turbo Off	Slew rate (1)	Unit
			Min	Max	Min	Max				
t_{ARPW}	CPLD register Clear or Preset Pulse Width		10		20			+ 12		ns
t_{ARD}	CPLD Array Delay	Any macrocell		11		16	+ 2			ns

1. Fast Slew Rate output available on Port C and Port F.

Table 63. CPLD macrocell Synchronous clock mode timing

Symbol	Parameter	Conditions	-70		-90		Fast PT Alloc	Turbo Off	Slew rate (1)	Unit
			Min	Max	Min	Max				
f_{MAX}	Maximum frequency External Feedback	$1/(t_S+t_{CO})$		34.4		30.30				MHz
	Maximum frequency Internal Feedback (f_{CNT})	$1/(t_S+t_{CO}-10)$		52.6		43.48				MHz
	Maximum frequency Pipelined Data	$1/(t_{CH}+t_{CL})$		83.3		50.00				MHz
t_S	Input setup time		14		15	+ 2	+ 12			ns
t_H	Input Hold time		0		0					ns
t_{CH}	Clock high time	Clock input	6		10					ns
t_{CL}	Clock low time	Clock input	6		10					ns
t_{CO}	Clock to output Delay	Clock input		15		18			- 2	ns
t_{ARD}	CPLD Array Delay	Any macrocell		11		16	+ 2			ns
t_{MIN}	Minimum Clock Period ⁽²⁾	$t_{CH}+t_{CL}$	12		20					ns

1. Fast Slew Rate output available on Port C and Port F.

2. CLKIN (PD1) $t_{CLCL} = t_{CH} + t_{CL}$.

Table 64. CPLD macrocell Asynchronous clock mode timing

Symbol	Parameter	Conditions	-70		-90		PT Alloc	Turbo Off	Slew rate	Unit
			Min	Max	Min	Max				
f _{MAXA}	Maximum frequency External Feedback	1/(t _{SA} +t _{COA})		38.4		26.32				MHz
	Maximum frequency Internal Feedback (f _{CNTA})	1/(t _{SA} +t _{COA} -10)		62.5		35.71				MHz
	Maximum frequency Pipelined Data	1/(t _{CHA} +t _{CLA})		47.6		37.03				MHz
t _{SA}	Input setup time		6		8	+ 2	+ 12			ns
t _{HA}	Input Hold time		7		12					ns
t _{CHA}	Clock input high time		9		12		+ 12			ns
t _{CLA}	Clock input low time		12		15		+ 12			ns
t _{COA}	Clock to output Delay			21		30		+ 12	- 2	ns
t _{ARDA}	CPLD Array Delay	Any macrocell		11		16	+ 2			ns
t _{MINA}	Minimum Clock Period	1/f _{CNTA}	16		28					ns

Figure 39. Synchronous clock mode timing - PLD

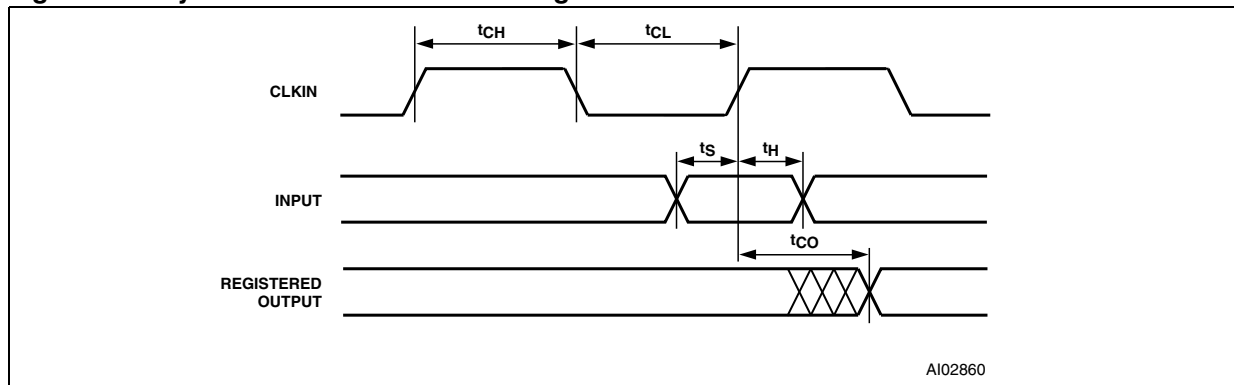

Figure 40. Asynchronous $\overline{\text{RESET}}$ / Preset

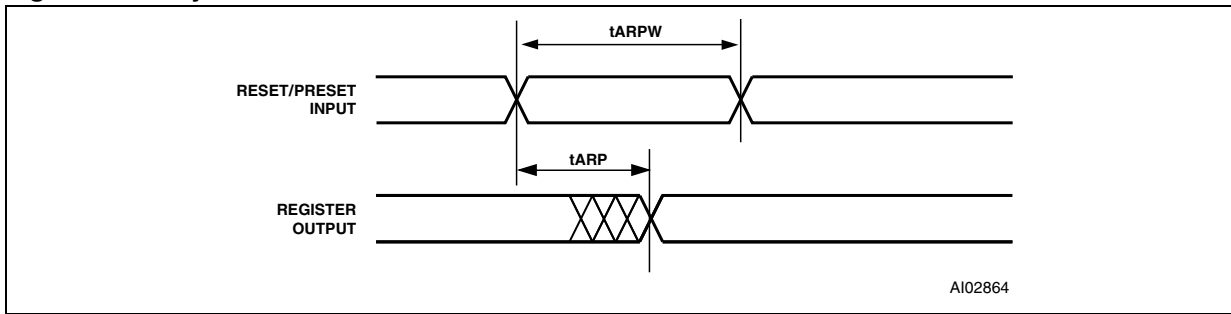

Figure 41. Asynchronous clock mode timing (product term clock)

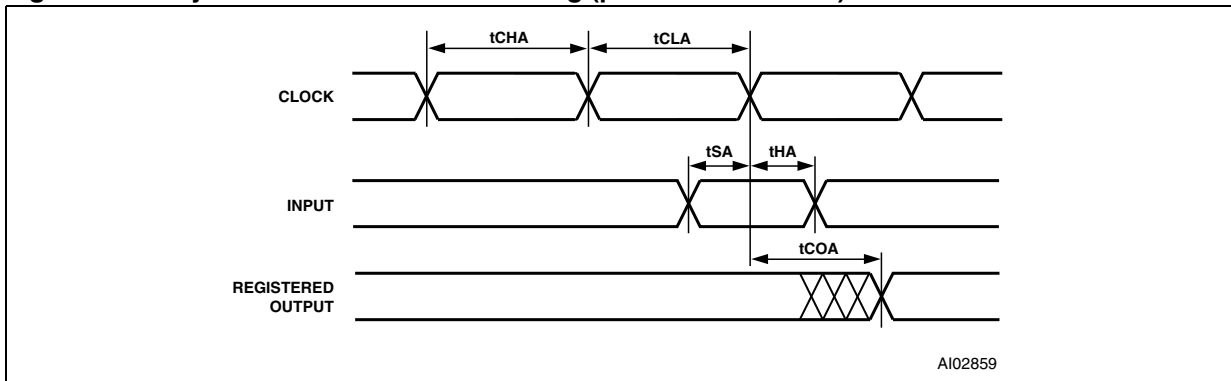

Figure 42. Input macrocell timing (product term clock)

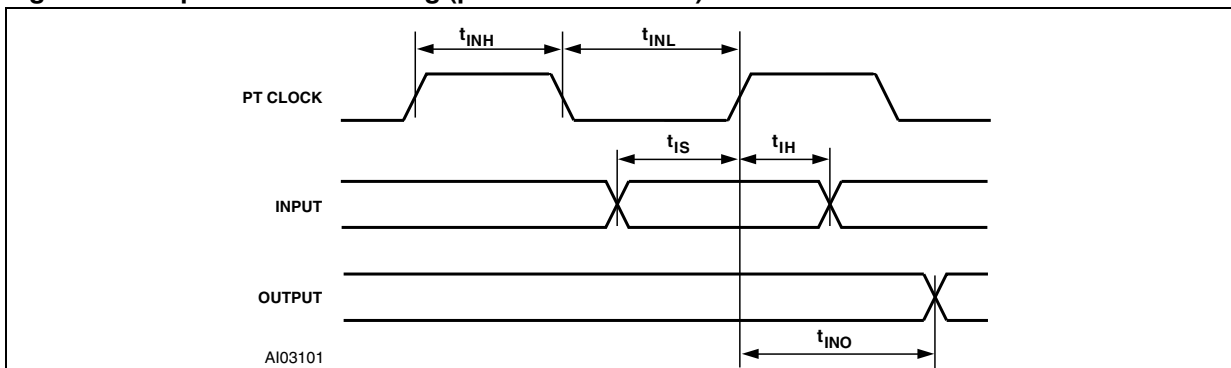

Table 65. Input macrocell timing

Symbol	Parameter	Conditions	-70		-90		PT Alloc	Turbo Off	Unit
			Min	Max	Min	Max			
t _{IS}	Input setup time	(1)	0		0				ns
t _{IH}	Input Hold time		15		20			+ 12	ns
t _{INH}	NIB input high time		9		12				ns
t _{INL}	NIB input low time		9		12				ns
t _{INO}	NIB input to combinatorial delay			34		46	+ 2	+ 12	ns

1. Inputs from Port A, B, and C relative to register/latch clock from the PLD. ALE latch timings refer to t_{AVLX} and t_{LXAX}.

Table 66. Program, WRITE and Erase times

Symbol	Parameter	Min.	Typ.	Max.	Unit
	Flash Program		8.5		s
	Flash Bulk Erase ⁽¹⁾ (pre-programmed)		3	30	s
	Flash Bulk Erase (not pre-programmed)		10		s
t _{WHQV3}	Sector Erase (pre-programmed)		1	30	s
t _{WHQV2}	Sector Erase (not pre-programmed)		2.2		s
t _{WHQV1}	Byte Program		14	1200	μs
	Program / Erase Cycles (per Sector)	100,000			cycles
t _{WHWLO}	Sector Erase timeout		100		μs
t _{Q7VQV}	DQ7 Valid to output (DQ7-DQ0) Valid (Data Polling) ⁽²⁾⁽³⁾			30	ns

1. Programmed to all zero before erase.
2. The polling status, DQ7, is valid t_{Q7VQV} time units before the data byte, DQ0-DQ7, is valid for reading.
3. DQ7 is DQ15 for Motorola MCU with 16-bit data bus.

Figure 43. Peripheral I/O write timing

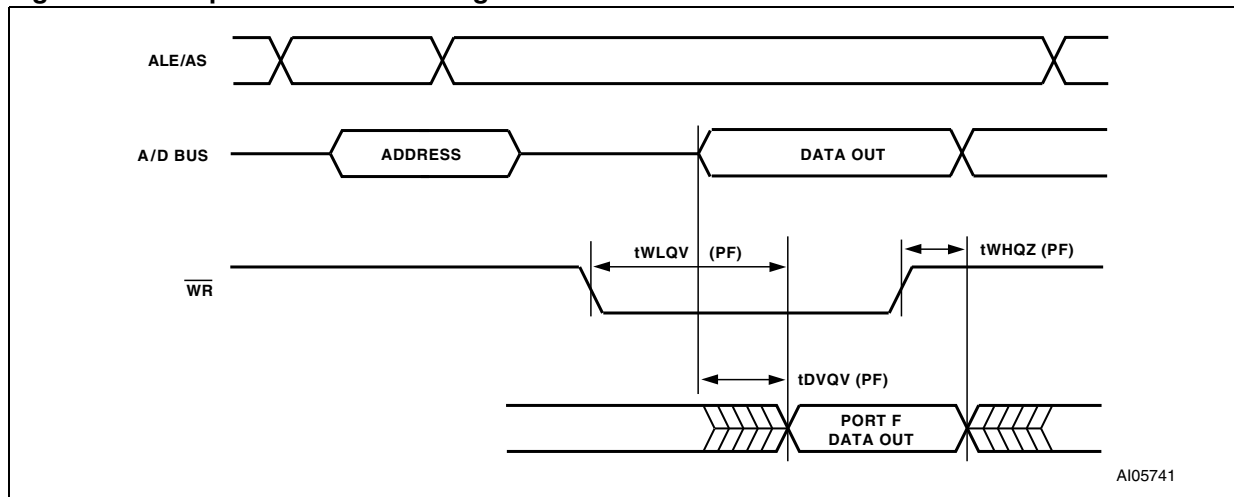

AI05741

Figure 44. READ timing

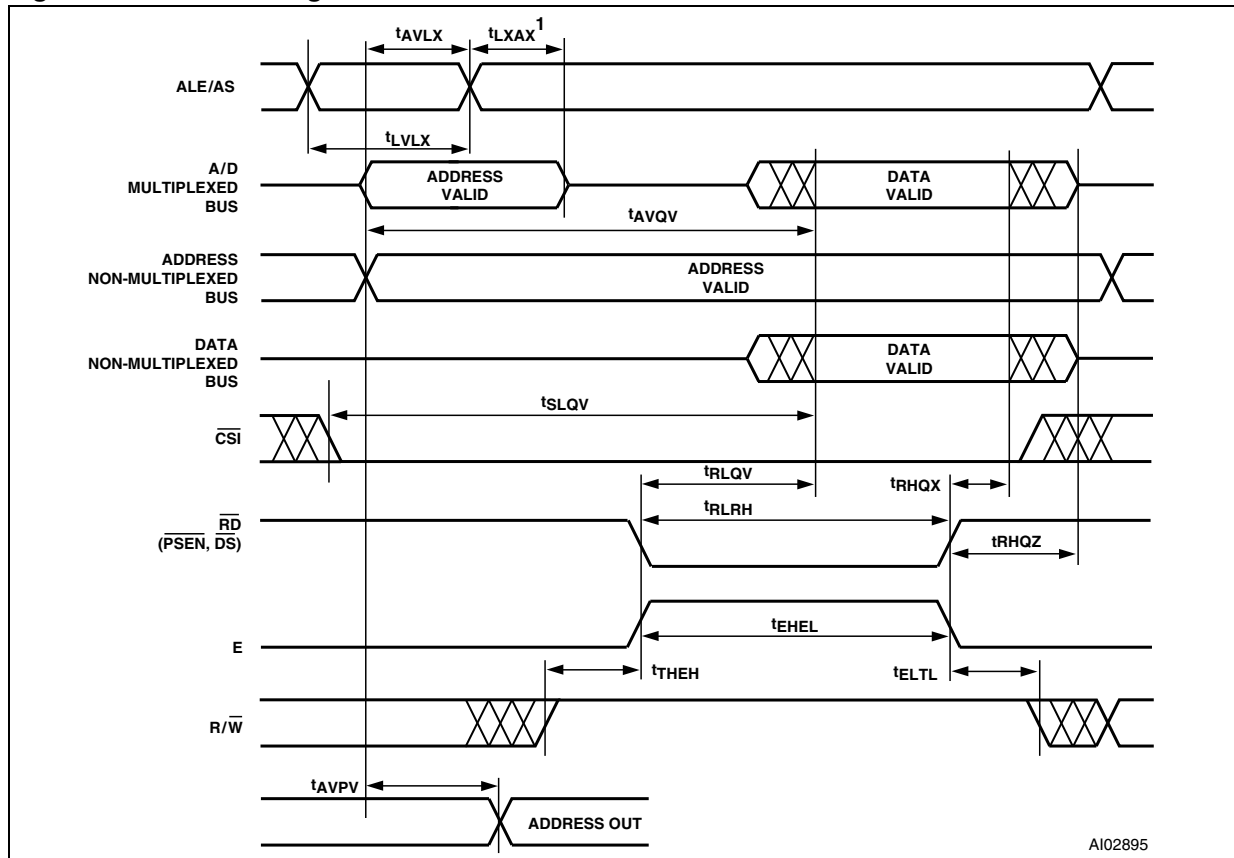

1. t_{AVLX} and t_{LXAX} are not required for 80C251 in Page Mode or 80C51XA in Burst Mode.

Table 67. READ timing

Symbol	Parameter	Conditions	-70		-90		Turbo Off	Unit
			Min	Max	Min	Max		
t_{LVLX}	ALE or AS Pulse Width		15		20			ns
t_{AVLX}	Address setup time	(1)	4		6			ns
t_{LXAX}	Address Hold time		7		8			ns
t_{AVQV}	Address Valid to Data Valid			70		90	+ 12	ns
t_{SLQV}	CS Valid to Data Valid			75		100		ns
t_{RLQV}	\overline{RD} to Data Valid 8-bit Bus	(2)		24		32		ns
	\overline{RD} or \overline{PSEN} to Data Valid 8-bit Bus, 8031, 80251	(3)		31		38		ns
t_{RHQX}	\overline{RD} Data Hold time	(4)	0		0			ns
t_{RLRH}	\overline{RD} Pulse Width		27		32			ns
t_{RHQZ}	\overline{RD} to Data high-Z			20		25		ns
t_{EHEL}	E Pulse Width		27		32			ns
t_{THEH}	R/\overline{W} setup time to Enable		6		10			ns

Table 67. READ timing (continued)

Symbol	Parameter	Conditions	-70		-90		Turbo Off	Unit
			Min	Max	Min	Max		
t_{ELTL}	R/ \overline{W} Hold time After Enable		0		0			ns
t_{AVPV}	Address input Valid to Address output Delay	(5)		20		25		ns

1. Any input used to select an internal PSD function.
2. \overline{RD} timing has the same timing as \overline{DS} , \overline{LDS} , and \overline{UDS} signals.
3. \overline{RD} and \overline{PSEN} have the same timing.
4. \overline{RD} timing has the same timing as \overline{DS} , \overline{LDS} , \overline{UDS} , and \overline{PSEN} signals.
5. In multiplexed mode, latched addresses generated from ADIO delay to address output on any Port.

Figure 45. WRITE timing

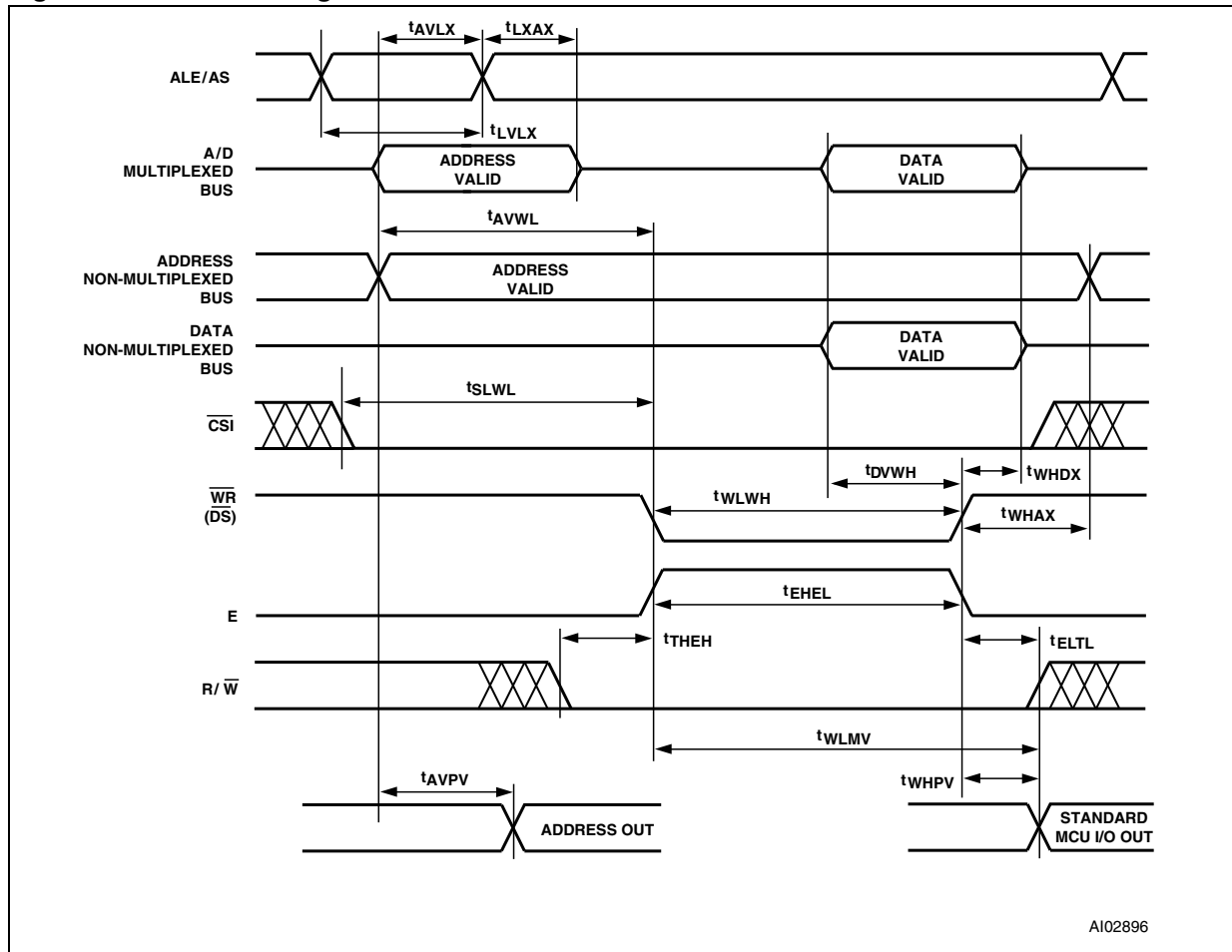

AI02896

Table 68. WRITE timing

Symbol	Parameter	Conditions	-70		-90		Unit
			Min	Max	Min	Max	
t_{LVLX}	ALE or AS Pulse Width		15		20		ns
t_{AVLX}	Address setup time	(1)	4		6		ns
t_{LXAX}	Address Hold time	(1)	7		8		ns
t_{AVWL}	Address Valid to Leading Edge of \overline{WR}	(1)(2)	8		15		ns
t_{SLWL}	\overline{CS} Valid to Leading edge of \overline{WR}	(2)	12		15		ns
t_{DVWH}	\overline{WR} Data setup time	(2)	25		35		ns
t_{WHDX}	\overline{WR} Data Hold time	(2)(3)	4		5		ns
t_{WLVH}	\overline{WR} Pulse Width	(2)	28		35		ns
t_{WHAX1}	Trailing edge of \overline{WR} to Address Invalid	(2)	6		8		ns
t_{WHAX2}	Trailing edge of \overline{WR} to DPLD Address Invalid	(2)(4)	0		0		ns

Table 68. WRITE timing

Symbol	Parameter	Conditions	-70		-90		Unit
			Min	Max	Min	Max	
t_{WHPV}	Trailing edge of \overline{WR} to Port output Valid Using I/O Port Data register	(2)		27		30	ns
t_{DVMV}	Data Valid to Port output Valid Using macrocell register Preset/Clear	(2)(5)		42		55	ns
t_{AVPV}	Address input Valid to Address Output Delay	(6)		20		25	ns
t_{WLMV}	\overline{WR} Valid to Port output Valid Using Macrocell register Preset/Clear	(2)(7)		48		55	ns

1. Any input used to select an internal PSD function.
2. \overline{WR} has the same timing as E, \overline{DS} , \overline{LDS} , \overline{UDS} , \overline{WRL} , and \overline{WRH} signals.
3. t_{WHAX} is 6 ns when writing to the output macrocell registers AB and BC.
4. t_{WHAX2} is the address hold time for DPLD inputs that are used to generate Sector Select signals for internal PSD memory.
5. Assuming WRITE is active before data becomes valid.
6. In multiplexed mode, latched address generated from ADIO delay to address output on any port.
7. Assuming data is stable before active WRITE signal.

Figure 46. Peripheral I/O read timing

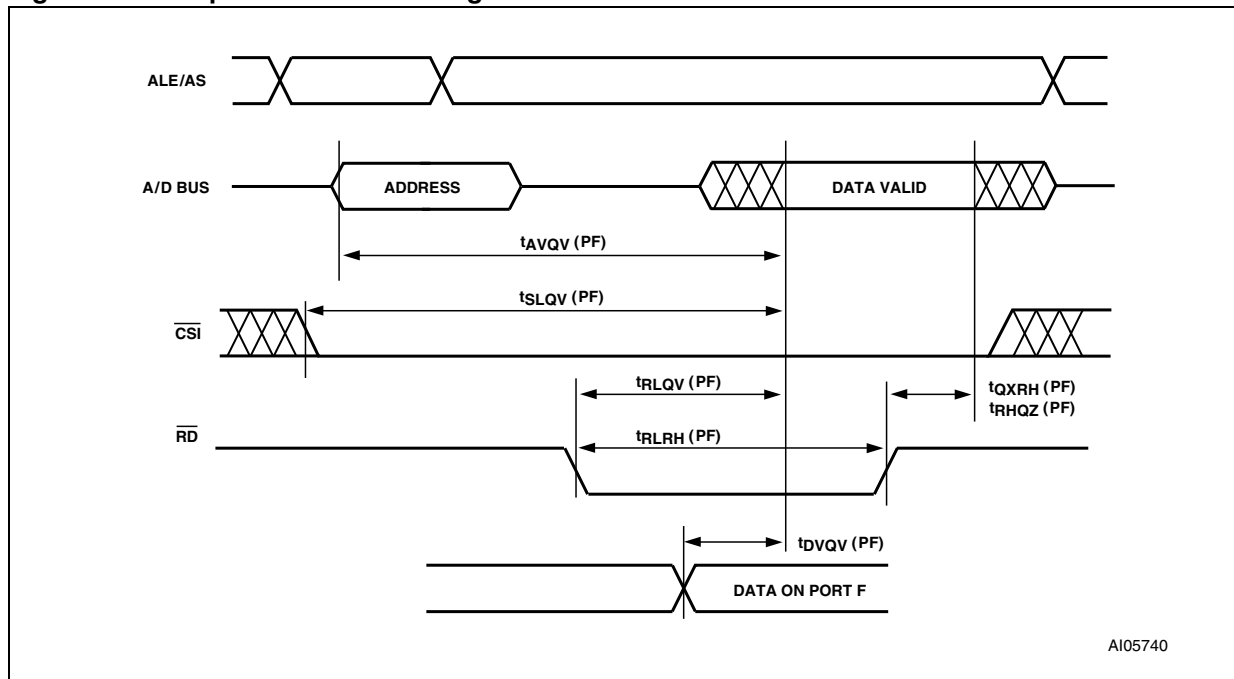

Table 69. Port F Peripheral Data Mode Read timing

Symbol	Parameter	Conditions	-70		-90		Turbo Off	Unit
			Min	Max	Min	Max		
$t_{AVQV-PF}$	Address Valid to Data Valid	(1)		30		35	+ 12	ns
$t_{SLQV-PF}$	\overline{CS} Valid to Data Valid			25		35	+ 12	ns
$t_{RLQV-PF}$	\overline{RD} to Data Valid	(2)(3)		21		32		ns
	\overline{RD} to Data Valid 8031 Mode			31		38		ns
$t_{DVQV-PF}$	Data In to Data Out Valid			22		30		ns
$t_{QXRH-PF}$	\overline{RD} Data Hold time		0		0			ns
$t_{RLRH-PF}$	\overline{RD} Pulse Width	(4)	27		32			ns
$t_{RHQZ-PF}$	\overline{RD} to Data high-Z			23		25		ns

- Any input used to select Port F Data Peripheral mode.
- \overline{RD} has the same timing as \overline{DS} , \overline{LDS} , \overline{UDS} , and \overline{PSEN} (in 8031 combined mode).
- Data is already stable on Port F.
- \overline{RD} has the same timing as \overline{DS} , \overline{LDS} , \overline{UDS} , and \overline{PSEN} (in 8031 combined mode).

Table 70. Port F Peripheral Data Mode Write timing

Symbol	Parameter	Conditions	-70		-90		Unit
			Min	Max	Min	Max	
$t_{WLQV-PF}$	\overline{WR} to Data Propagation Delay	(1)		25		35	ns
$t_{DVQV-PF}$	Data to Port F Data Propagation Delay	(2)		22		30	ns
$t_{WHQZ-PF}$	\overline{WR} Invalid to Port F Tri-state	(1)		20		25	ns

- \overline{WR} has the same timing as the E, \overline{LDS} , \overline{UDS} , \overline{WRL} , and \overline{WRH} signals.
- Data stable on ADIO pins to data on Port F.

Figure 47. Reset (\overline{RESET}) timing

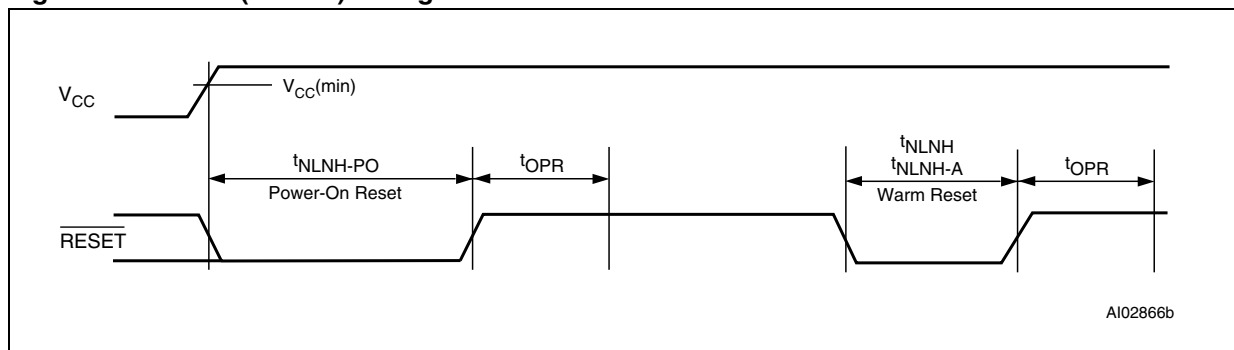

Table 71. Reset (\overline{RESET}) timing

Symbol	Parameter	Conditions	Min	Max	Unit
t_{NLNH}	\overline{RESET} Active low time ⁽¹⁾		150		ns
$t_{NLNH-PO}$	Power-on Reset Active low time		1		ms

Table 71. Reset ($\overline{\text{RESET}}$) timing

Symbol	Parameter	Conditions	Min	Max	Unit
$t_{\text{NLNH-A}}$	Warm Reset ⁽²⁾		25		μs
t_{OPR}	$\overline{\text{RESET}}$ high to Operational Device			120	ns

- Reset ($\overline{\text{RESET}}$) does not reset Flash memory Program or Erase cycles.
- Warm reset aborts Flash memory Program or Erase cycles, and puts the device in READ mode.

Table 72. Power-down timing

Symbol	Parameter	Conditions	-70		-90		Unit
			Min	Max	Min	Max	
t_{LVDV}	ALE Access time from Power-down			80		90	ns
t_{CLWH}	Maximum Delay from APD Enable to Internal PDN Valid Signal	Using CLKIN (PD1)	$15 * t_{\text{CLCL}}^{(1)}$				μs

- t_{CLCL} is the period of CLKIN (PD1).

Figure 48. ISC timing

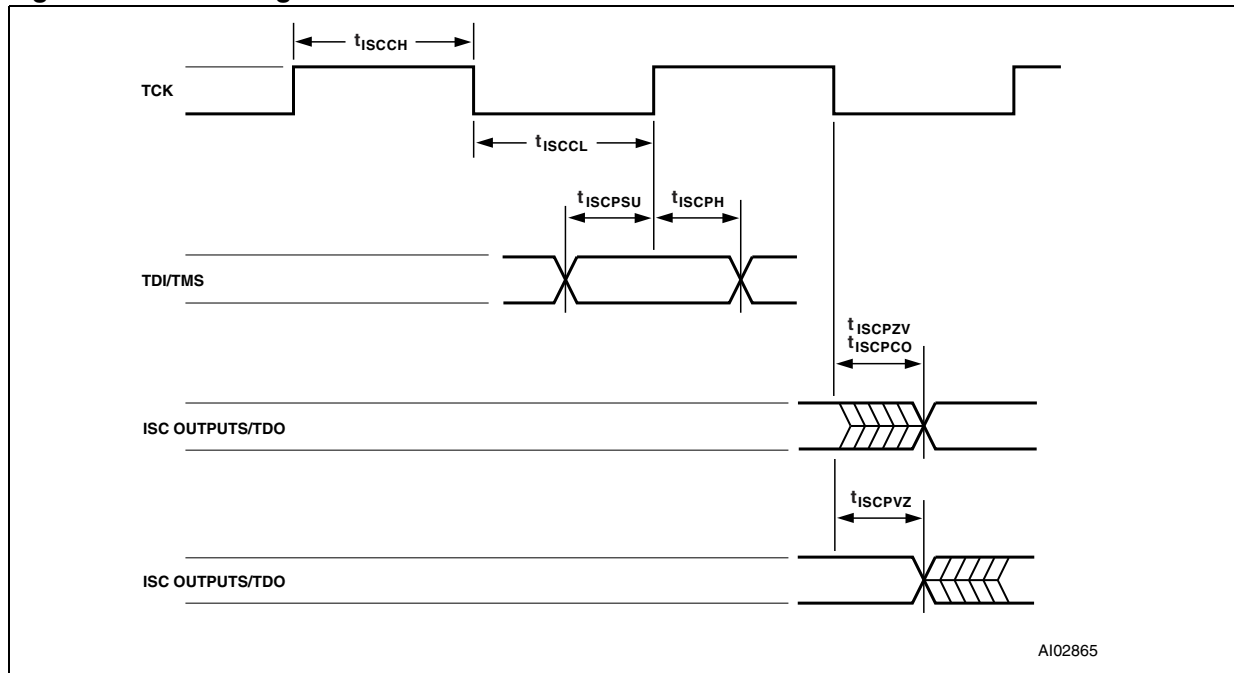

Table 73. ISC timing

Symbol	Parameter	Conditions	-70		-90		Unit
			Min	Max	Min	Max	
t_{ISCCF}	Clock (TCK, PC1) frequency (except for PLD)	(1)		20		18	MHz
t_{ISCCCH}	Clock (TCK, PC1) high time (except for PLD)		23		26		ns
t_{ISCCCL}	Clock (TCK, PC1) low time (except for PLD)		23		26		ns
t_{ISCCFP}	Clock (TCK, PC1) frequency (PLD only)	(2)		2		2	MHz
t_{ISCCHP}	Clock (TCK, PC1) high time (PLD only)		240		240		ns
t_{ISCCLP}	Clock (TCK, PC1) low time (PLD only)		240		240		ns
$t_{ISCPUSU}$	ISC Port Setup time		6		8		ns
t_{ISCPH}	ISC Port Hold Up time		5		5		ns
t_{ISPCO}	ISC Port Clock to output			21		23	ns
t_{ISCPZV}	ISC Port high-Impedance to Valid output			21		23	ns
t_{ISCPVZ}	ISC Port Valid output to High-Impedance			21		23	ns

1. For non-PLD Programming, Erase or in ISC by-pass mode.

2. For Program or Erase PLD only.

27 Package mechanical

In order to meet environmental requirements, ST offers these devices in different grades of ECOPACK® packages, depending on their level of environmental compliance.

ECOPACK® specifications, grade definitions and product status are available at: www.st.com. ECOPACK® is an ST trademark.

Figure 49. LQFP80 - 80-lead plastic thin, quad, flat package outline

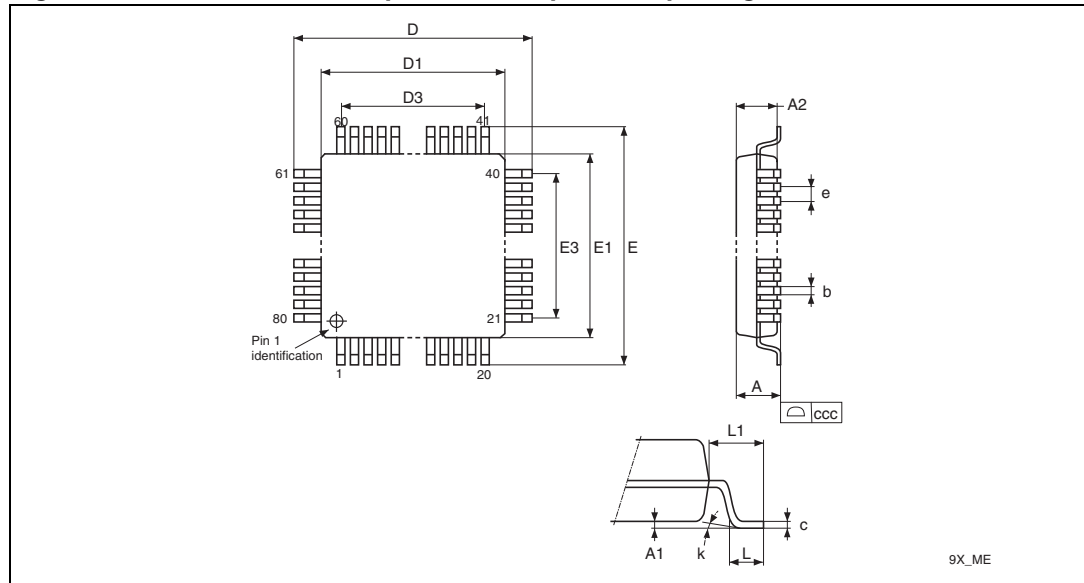

1. Drawing is not to scale.

Table 74. LQFP80 - 80-lead plastic thin, quad, flat package mechanical data⁽¹⁾

Symb	mm			inches		
	Typ	Min	Max	Typ	Min	Max
A	–	–	1.600	–	–	0.0630
A1	–	0.050	0.150	–	0.0020	0.0060
A2	1.400	1.350	1.450	0.0550	0.0530	0.0570
b	0.220	0.170	0.270	0.0090	0.0070	0.0110
c	–	0.090	0.200	–	0.0040	0.0080
D	14.000	–	–	0.5510	–	–
D1	12.000	–	–	0.4720	–	–
D3	9.500	–	–	0.3740	–	–
E	14.000	–	–	0.5510	–	–
E1	12.000	–	–	0.4720	–	–
E3	9.500	–	–	0.3740	–	–
e	0.500	–	–	0.0200	–	–

Table 74. LQFP80 - 80-lead plastic thin, quad, flat package mechanical data⁽¹⁾

Symb	mm			inches		
	Typ	Min	Max	Typ	Min	Max
L	0.600	0.450	0.750	0.0240	0.0180	0.0300
L1	1.000	–	–	0.0390	–	–
k		0°	7°	3.5	0°	7°
ccc		0.080		–	–	0.003

1. Values in inches are converted from mm and rounded to 4 decimal digits.

28 Part numbering

Table 75. Ordering information scheme

Example:	PSD42	3	5	G	2	-	90	U	1	T
Device Type										
PSD42 = Flash PSD with CPLD										
SRAM Size										
3 = 64 Kbit										
Flash Memory Size										
5 = 4 Mbit										
I/O Count										
G = 52 I/O										
2nd Non-Volatile Memory										
2 = 256 Kbit Flash memory										
Operating voltage										
blank = $V_{CC} = 4.5$ to $5.5V$ $V^{(1)} = V_{CC} = 3.0$ to $3.6V$										
Speed										
70 = 70ns 90 = 90ns 12 = 120ns										
Package										
U = ECOPACK LQFP80										
Temperature Range										
blank = 0 to 70°C (Commercial) I = -40 to 85°C (Industrial)										
Option										
T = Tape & Reel Packing										

1. The 3.3V±10% devices are not covered by this data sheet, but by the PSD4235G2V data sheet.

For a list of available options (e.g., Speed, Package) or for further information on any aspect of this device, please contact the ST Sales Office nearest to you.

Appendix A Pin assignments

Table 76. PSD4235G2 LQFP80

Pin No.	Pin assignments	Pin No.	Pin assignments	Pin No.	Pin assignments	Pin No.	Pin assignments
1	PD2	21	PG0	41	PC0	61	PB0
2	PD3	22	PG1	42	PC1	62	PB1
3	AD0	23	PG2	43	PC2	63	PB2
4	AD1	24	PG3	44	PC3	64	PB3
5	AD2	25	PG4	45	PC4	65	PB4
6	AD3	26	PG5	46	PC5	66	PB5
7	AD4	27	PG6	47	PC6	67	PB6
8	GND	28	PG7	48	PC7	68	PB7
9	V _{CC}	29	V _{CC}	49	GND	69	V _{CC}
10	AD5	30	GND	50	GND	70	GND
11	AD6	31	PF0	51	PA0	71	PE0
12	AD7	32	PF1	52	PA1	72	PE1
13	AD8	33	PF2	53	PA2	73	PE2
14	AD9	34	PF3	54	PA3	74	PE3
15	AD10	35	PF4	55	PA4	75	PE4
16	AD11	36	PF5	56	PA5	76	PE5
17	AD12	37	PF6	57	PA6	77	PE6
18	AD13	38	PF7	58	PA7	78	PE7
19	AD14	39	$\overline{\text{RESET}}$	59	CNTL0	79	PD0
20	AD15	40	CNTL2	60	CNTL1	80	PD1

29 Revision history

Table 77. Document revision history

Date	Revision	Changes
May 01, 2001	1.0	Initial release as a WSI document
01-Aug-01	1.1	Timing parameters updated
12-Sep-01	2.0	Document rewritten using the ST template
14-Dec-01	2.1	Information on the 3.3V±10% range removed to a separate data sheet
11-Mar-04	3.0	Reformatted; corrected mechanical dimension, ordering (Table 74 , Table 75)
12-Feb-09	4	Document reformatted. SRAM standby mode and backup battery feature removed. All products are delivered in ECOPACK-compliant packages. Changed TQFP80 into LQFP80 and updated Section 27: Package mechanical . Small text changes. Regrouped sections AC/DC parameters, and DC and AC parameters.

Please Read Carefully:

Information in this document is provided solely in connection with ST products. STMicroelectronics NV and its subsidiaries ("ST") reserve the right to make changes, corrections, modifications or improvements, to this document, and the products and services described herein at any time, without notice.

All ST products are sold pursuant to ST's terms and conditions of sale.

Purchasers are solely responsible for the choice, selection and use of the ST products and services described herein, and ST assumes no liability whatsoever relating to the choice, selection or use of the ST products and services described herein.

No license, express or implied, by estoppel or otherwise, to any intellectual property rights is granted under this document. If any part of this document refers to any third party products or services it shall not be deemed a license grant by ST for the use of such third party products or services, or any intellectual property contained therein or considered as a warranty covering the use in any manner whatsoever of such third party products or services or any intellectual property contained therein.

UNLESS OTHERWISE SET FORTH IN ST'S TERMS AND CONDITIONS OF SALE ST DISCLAIMS ANY EXPRESS OR IMPLIED WARRANTY WITH RESPECT TO THE USE AND/OR SALE OF ST PRODUCTS INCLUDING WITHOUT LIMITATION IMPLIED WARRANTIES OF MERCHANTABILITY, FITNESS FOR A PARTICULAR PURPOSE (AND THEIR EQUIVALENTS UNDER THE LAWS OF ANY JURISDICTION), OR INFRINGEMENT OF ANY PATENT, COPYRIGHT OR OTHER INTELLECTUAL PROPERTY RIGHT.

UNLESS EXPRESSLY APPROVED IN WRITING BY AN AUTHORIZED ST REPRESENTATIVE, ST PRODUCTS ARE NOT RECOMMENDED, AUTHORIZED OR WARRANTED FOR USE IN MILITARY, AIR CRAFT, SPACE, LIFE SAVING, OR LIFE SUSTAINING APPLICATIONS, NOR IN PRODUCTS OR SYSTEMS WHERE FAILURE OR MALFUNCTION MAY RESULT IN PERSONAL INJURY, DEATH, OR SEVERE PROPERTY OR ENVIRONMENTAL DAMAGE. ST PRODUCTS WHICH ARE NOT SPECIFIED AS "AUTOMOTIVE GRADE" MAY ONLY BE USED IN AUTOMOTIVE APPLICATIONS AT USER'S OWN RISK.

Resale of ST products with provisions different from the statements and/or technical features set forth in this document shall immediately void any warranty granted by ST for the ST product or service described herein and shall not create or extend in any manner whatsoever, any liability of ST.

ST and the ST logo are trademarks or registered trademarks of ST in various countries.

Information in this document supersedes and replaces all information previously supplied.

The ST logo is a registered trademark of STMicroelectronics. All other names are the property of their respective owners.

© 2009 STMicroelectronics - All rights reserved

STMicroelectronics group of companies

Australia - Belgium - Brazil - Canada - China - Czech Republic - Finland - France - Germany - Hong Kong - India - Israel - Italy - Japan - Malaysia - Malta - Morocco - Singapore - Spain - Sweden - Switzerland - United Kingdom - United States of America

www.st.com



Looking for pricing, stock, or lifecycle information?

Click below to explore more details on WIN SOURCE:

- ⊖ [View PSD4235G2-90U on WIN SOURCE](#)
- ⊖ [STMicroelectronics Information](#)

Optimize Your Supply Chain with WIN SOURCE Solutions

- ✓ Global Sourcing Solution
- ✓ Obsolete Management
- ✓ Cost Control Management
- ✓ Shortage Management
- ✓ Alternative Solution
- ✓ Excess Inventory Management