



THE DATASHEET OF SN74LVC74ADBRG4



Table of Contents

1 Features	1	7 Detailed Description	10
2 Applications	1	7.1 Overview.....	10
3 Description	1	7.2 Functional Block Diagram.....	10
4 Pin Configuration and Functions	3	7.3 Feature Description.....	10
5 Specifications	4	7.4 Device Functional Modes.....	10
5.1 Absolute Maximum Ratings.....	4	8 Application and Implementation	11
5.2 ESD Ratings.....	4	8.1 Application Information.....	11
5.3 Recommended Operating Conditions.....	4	8.2 Typical Application.....	11
5.4 Thermal Information: SN74LVC74A.....	5	8.3 Power Supply Recommendations.....	12
5.5 Electrical Characteristics.....	5	8.4 Layout.....	12
5.6 Timing Requirements: SN54LVC74A.....	6	9 Device and Documentation Support	14
5.7 Timing Requirements: SN74LVC74A.....	6	9.1 Documentation Support.....	14
5.8 Timing Requirements: SN74LVC74A, –40°C to 125°C and –40°C to 85°C.....	7	9.2 Receiving Notification of Documentation Updates... 14	14
5.9 Switching Characteristics: SN54LVC74A.....	7	9.3 Support Resources.....	14
5.10 Switching Characteristics: SN74LVC74A.....	7	9.4 Trademarks.....	14
5.11 Switching Characteristics: SN74LVC74A, – 40°C to 125°C and –40°C to 85°C.....	8	9.5 Electrostatic Discharge Caution.....	14
5.12 Operating Characteristics.....	8	9.6 Glossary.....	14
5.13 Typical Characteristics.....	8	10 Revision History	14
6 Parameter Measurement Information	9	11 Mechanical, Packaging, and Orderable Information	15

4 Pin Configuration and Functions

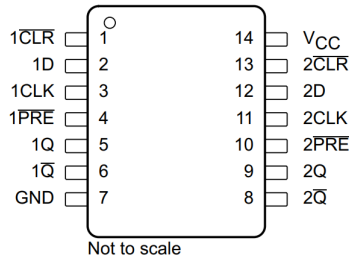

Figure 4-1. D, DB, J, PW, NS, or W Package 14-Pin SOIC, SSOP, CDIP, TSSOP, SO, or CFP (Top View)

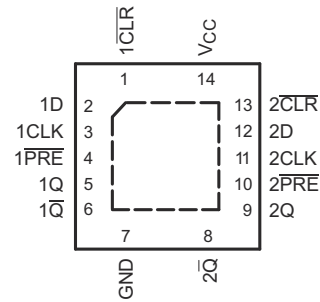

Figure 4-2. BQA or RGY Package 14-Pin WQFN or VQFN With Exposed Thermal Pad (Top View)

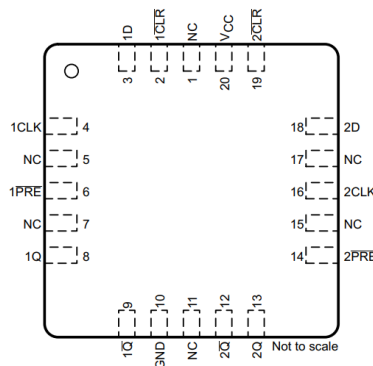

Figure 4-3. FK Package 20-Pin LCCC (Top View)

Table 4-1. Pin Functions

NAME	PIN		I/O	DESCRIPTION
	CDIP, CFP, PDIP, SO, SOIC, SSOP, TSSOP, VQFN	LCCC		
1CLK	3	4	I	Channel 1 clock input
1 CLR	1	2	I	Channel 1 clear input. Pull low to set Q output low.
1D	2	3	I	Channel 1 data input
1 PRE	4	6	I	Channel 1 preset input. Pull low to set Q output high.
1Q	5	8	O	Channel 1 output
1 Q̄	6	9	O	Channel 1 inverted output
2CLK	11	16	I	Channel 2 clock input
2 CLR	13	19	I	Channel 2 clear input. Pull low to set Q output low.
2D	12	18	I	Channel 2 data input
2 PRE	10	14	I	Channel 2 preset input. Pull low to set Q output high.
2Q	9	13	O	Channel 2 output
2 Q̄	8	12	O	Channel 2 Inverted output
GND	7	10	—	Ground
NC	—	1, 5, 7, 11, 15, 17	—	No connect
VCC	14	20	—	Supply

5 Specifications

5.1 Absolute Maximum Ratings

over operating free-air temperature range (unless otherwise noted)⁽¹⁾

	MIN	MAX	UNIT
Supply voltage, V_{CC}	-0.5	6.5	V
Input voltage, V_I ⁽²⁾	-0.5	6.5	V
Output voltage, V_O ^{(2) (3)}	-0.5	$V_{CC} + 0.5$	V
Input clamp current, I_{IK}	$V_I < 0$	-50	mA
Output clamp current, I_{OK}	$V_O < 0$	-50	mA
Continuous output current, I_O		±50	mA
Continuous current through V_{CC} or GND		±100	mA
Storage temperature, T_{stg}	-65	150	°C

- (1) Stresses beyond those listed under *Absolute Maximum Ratings* may cause permanent damage to the device. These are stress ratings only, which do not imply functional operation of the device at these or any other conditions beyond those indicated under *Recommended Operating Conditions*. Exposure to absolute-maximum-rated conditions for extended periods may affect device reliability.
- (2) The input and output negative-voltage ratings may be exceeded if the input and output current ratings are observed.
- (3) The value of V_{CC} is provided in *Recommended Operating Conditions*.

5.2 ESD Ratings

	VALUE	UNIT
$V_{(ESD)}$ Electrostatic discharge	Human-body model (HBM), per ANSI/ESDA/JEDEC JS-001 ⁽¹⁾	±2000
	Charged-device model (CDM), per JEDEC specification JESD22-C101 ⁽²⁾	±1000

- (1) JEDEC document JEP155 states that 500-V HBM allows safe manufacturing with a standard ESD control process.
- (2) JEDEC document JEP157 states that 250-V CDM allows safe manufacturing with a standard ESD control process.

5.3 Recommended Operating Conditions

see⁽¹⁾

			MIN	MAX	UNIT
V_{CC} Supply voltage	Operating	SN54LVC74A	2	3.6	V
		SN74LVC74A	1.65	3.6	
	Data retention only		1.5		
V_{IH} High-level input voltage	$V_{CC} = 1.65\text{ V to }1.95\text{ V}$	SN74LVC74A	$0.65 \times V_{CC}$		V
	$V_{CC} = 2.3\text{ V to }2.7\text{ V}$	SN74LVC74A	1.7		
	$V_{CC} = 2.7\text{ V to }3.6\text{ V}$		2		
V_{IL} Low-level input voltage	$V_{CC} = 1.65\text{ V to }1.95\text{ V}$	SN74LVC74A	$0.35 \times V_{CC}$		V
	$V_{CC} = 2.3\text{ V to }2.7\text{ V}$	SN74LVC74A	0.7		
	$V_{CC} = 2.7\text{ V to }3.6\text{ V}$		0.8		
V_I Input voltage			0	5.5	V
V_O Output voltage			0	V_{CC}	V
I_{OH} High-level output current	$V_{CC} = 1.65\text{ V}$	SN74LVC74A	-4		mA
	$V_{CC} = 2.3\text{ V}$	SN74LVC74A	-8		
	$V_{CC} = 2.7\text{ V}$		-12		
	$V_{CC} = 3\text{ V}$		-24		
I_{OL} Low-level output current	$V_{CC} = 1.65\text{ V}$	SN74LVC74A	4		mA
	$V_{CC} = 2.3\text{ V}$	SN74LVC74A	8		
	$V_{CC} = 2.7\text{ V}$		12		
	$V_{CC} = 3\text{ V}$		24		
$\Delta t/\Delta v$ Input transition rise or fall rate			10		ns/V

5.3 Recommended Operating Conditions (continued)

see⁽¹⁾

			MIN	MAX	UNIT
T _A	Operating free-air temperature	SN54LVC74A	-55	125	°C
		SN74LVC74A	-40	125	

- (1) All unused inputs of the device must be held at V_{CC} or GND to ensure proper device operation. See the TI application report, [Implications of Slow or Floating CMOS Inputs](#) (SCBA004).

5.4 Thermal Information: SN74LVC74A

THERMAL METRIC ⁽¹⁾		SN74LVC74A						UNIT
		BQA (WQFN)	D (SOIC)	DB (SSOP)	NS (SO)	PW (TSSOP)	RGY (VQFN)	
		14 PINS	14 PINS	14 PINS	14 PINS	14 PINS	14 PINS	
R _{θJA}	Junction-to-ambient thermal resistance	102.3	93.7	107.3	90.3	121.7	54.9	°C/W
R _{θJC(top)}	Junction-to-case (top) thermal resistance	96.8	54.8	59.2	48.1	50.3	52.2	°C/W
R _{θJB}	Junction-to-board thermal resistance	70.9	48	54.6	49.1	63.4	30.8	°C/W
ψ _{JT}	Junction-to-top characterization parameter	16.6	20.3	24.1	17.9	6.2	2.4	°C/W
ψ _{JB}	Junction-to-board characterization parameter	70.9	47.7	54.1	48.8	62.8	30.9	°C/W
R _{θJC(bot)}	Junction-to-case (bottom) thermal resistance	50.1	—	—	—	—	12.5	°C/W

- (1) For more information about traditional and new thermal metrics, see the [Semiconductor and IC Package Thermal Metrics](#) application report.

5.5 Electrical Characteristics

over recommended operating free-air temperature range (unless otherwise noted)

PARAMETER		TEST CONDITIONS		MIN	TYP	MAX	UNIT
V _{OH}	High-level output voltage	I _{OH} = -100 μA	V _{CC} = 1.65 V to 3.6 V and T _A = -55°C to 125°C (SN54LVC74A only)	V _{CC} - 0.2			V
			V _{CC} = 2.7 V to 3.6 V and T _A = -40°C to 125°C (SN74LVC74A only)	V _{CC} - 0.2			
		I _{OH} = -4 mA, V _{CC} = 1.65 V, and T _A = -40°C to 125°C (SN74LVC74A only)		1.2			
		I _{OH} = -8 mA, V _{CC} = 2.3 V, and T _A = -40°C to 125°C (SN74LVC74A only)		1.7			
		I _{OH} = -12 mA	V _{CC} = 2.7 V	2.2			
			V _{CC} = 3 V	2.4			
I _{OH} = -24 mA, V _{CC} = 3 V		2.2					
V _{OL}	Low-level output voltage	I _{OL} = 100 μA	V _{CC} = 1.65 V to 3.6 V, and T _A = -40°C to 125°C (SN74LVC74A only)			0.2	V
			V _{CC} = 2.7 V to 3.6 V and T _A = -55°C to 125°C (SN54LVC74A only)			0.2	
		I _{OL} = 4 mA, V _{CC} = 1.65 V, and T _A = -40°C to 125°C (SN74LVC74A only)				0.45	
		I _{OL} = 8 mA, V _{CC} = 2.3 V, and T _A = -40°C to 125°C (SN74LVC74A only)				0.7	
		I _{OL} = 12 mA, V _{CC} = 2.7 V				0.4	
		I _{OL} = 24 mA, V _{CC} = 3 V				0.55	
I _I	Input current	V _I = 5.5 V or GND, V _{CC} = 3.6 V				±5	μA
I _{CC}	Supply current	V _I = V _{CC} or GND, I _O = 0, V _{CC} = 3.6 V				10	μA

5.5 Electrical Characteristics (continued)

over recommended operating free-air temperature range (unless otherwise noted)

PARAMETER		TEST CONDITIONS	MIN	TYP	MAX	UNIT
ΔI_{CC}	Change in supply current	One input at $V_{CC} - 0.6$ V, other inputs at V_{CC} or GND, and $V_{CC} = 2.7$ V to 3.6 V			500	μ A
C_i	Input capacitance	$V_i = V_{CC}$ or GND, $V_{CC} = 3.3$ V, $T_A = 25^\circ$ C		5		pF

5.6 Timing Requirements: SN54LVC74A

over recommended operating free-air temperature range (unless otherwise noted; see [Parameter Measurement Information](#))

			MIN	MAX	UNIT
f_{clock}	Clock frequency	$V_{CC} = 2.7$ V		83	MHz
		$V_{CC} = 3.3$ V \pm 0.3 V		100	
t_w	Pulse duration	\overline{PRE} or \overline{CLR} low	3.3		ns
		CLK high or low	3.3		
t_{su}	Setup time before CLK \uparrow	Data	$V_{CC} = 2.7$ V	3.4	ns
			$V_{CC} = 3.3$ V \pm 0.3 V	3	
		\overline{PRE} or \overline{CLR} inactive	$V_{CC} = 2.7$ V	2.2	
			$V_{CC} = 3.3$ V \pm 0.3 V	2	
t_h	Hold time, data after CLK \uparrow		1	ns	

5.7 Timing Requirements: SN74LVC74A

over recommended operating free-air temperature range (unless otherwise noted; see [Parameter Measurement Information](#))

			MIN	MAX	UNIT
f_{clock}	Clock frequency	$V_{CC} = 1.8$ V or 2.5 V		83	MHz
t_w	Pulse duration	\overline{PRE} or \overline{CLR} low	$V_{CC} = 1.8$ V \pm 0.15 V	4.1	ns
			$V_{CC} = 2.5$ V \pm 0.2 V	3.3	
		CLK high or low	$V_{CC} = 1.8$ V \pm 0.15 V	4.1	
			$V_{CC} = 2.5$ V \pm 0.2 V	3.3	
t_{su}	Setup time before CLK \uparrow	Data	$V_{CC} = 1.8$ V \pm 0.15 V	3.6	ns
			$V_{CC} = 2.5$ V \pm 0.2 V	2.3	
		\overline{PRE} or \overline{CLR} inactive	$V_{CC} = 1.8$ V \pm 0.15 V	2.7	
			$V_{CC} = 2.5$ V \pm 0.2 V	1.9	
t_h	Hold time, data after CLK \uparrow	$V_{CC} = 1.8$ V or 2.5 V	1	ns	

5.8 Timing Requirements: SN74LVC74A, –40°C to 125°C and –40°C to 85°C

over recommended operating free-air temperature range (unless otherwise noted; see [Parameter Measurement Information](#))

				MIN	MAX	UNIT
f_{clock}	Clock frequency	$T_A = -40^\circ\text{C}$ to 125°C	$V_{\text{CC}} = 2.7\text{ V}$		83	MHz
			$V_{\text{CC}} = 3.3\text{ V} \pm 0.3\text{ V}$		100	
		$T_A = -40^\circ\text{C}$ to 85°C and $V_{\text{CC}} = 3.3\text{ V} \pm 0.3\text{ V}$				
t_w	Pulse duration	$\overline{\text{PRE}}$ or $\overline{\text{CLR}}$ low	$V_{\text{CC}} = 2.7\text{ V}$ or 3.3 V		3.3	ns
		CLK high or low	$V_{\text{CC}} = 2.7\text{ V}$ or 3.3 V		3.3	
t_{su}	Setup time before CLK \uparrow	Data	$T_A = -40^\circ\text{C}$ to 125°C	$V_{\text{CC}} = 2.7\text{ V}$	3.4	ns
				$V_{\text{CC}} = 3.3\text{ V} \pm 0.3\text{ V}$	3	
			$T_A = -40^\circ\text{C}$ to 85°C and $V_{\text{CC}} = 3.3\text{ V} \pm 0.3\text{ V}$		3	
		$\overline{\text{PRE}}$ or $\overline{\text{CLR}}$ inactive	$T_A = -40^\circ\text{C}$ to 125°C	$V_{\text{CC}} = 2.7\text{ V}$	2.2	
				$V_{\text{CC}} = 3.3\text{ V} \pm 0.3\text{ V}$	2	
$T_A = -40^\circ\text{C}$ to 85°C and $V_{\text{CC}} = 3.3\text{ V} \pm 0.3\text{ V}$		2				
t_h	Hold time, data after CLK \uparrow	$V_{\text{CC}} = 2.7\text{ V}$ or 3.3 V		1	ns	

5.9 Switching Characteristics: SN54LVC74A

over recommended operating free-air temperature range (unless otherwise noted; see [Parameter Measurement Information](#))

PARAMETER	FROM (INPUT)	TO (OUTPUT)	TEST CONDITIONS	MIN	MAX	UNIT	
f_{max}	Maximum clock frequency	—	$V_{\text{CC}} = 2.7\text{ V}$	83		MHz	
			$V_{\text{CC}} = 3.3\text{ V} \pm 0.3\text{ V}$	100			
t_{pd}	Propagation (delay) time	CLK	$V_{\text{CC}} = 2.7\text{ V}$		6	ns	
			$V_{\text{CC}} = 2.7\text{ V}$	1	5.2		
		$\overline{\text{PRE}}$ or $\overline{\text{CLR}}$	Q or $\overline{\text{Q}}$	$V_{\text{CC}} = 3.3\text{ V} \pm 0.3\text{ V}$			6.4
				$V_{\text{CC}} = 3.3\text{ V} \pm 0.3\text{ V}$	1		5.4

5.10 Switching Characteristics: SN74LVC74A

over recommended operating free-air temperature range (unless otherwise noted; see [Parameter Measurement Information](#))

PARAMETER	FROM (INPUT)	TO (OUTPUT)	TEST CONDITIONS	MIN	MAX	UNIT	
f_{max}	Maximum clock frequency	—		83		MHz	
t_{pd}	Propagation (delay) time	CLK $\overline{\text{PRE}}$	$V_{\text{CC}} = 1.8\text{ V} \pm 0.15\text{ V}$	1	7.1	ns	
			$V_{\text{CC}} = 2.5\text{ V} \pm 0.2\text{ V}$	1	4.4		
		or $\overline{\text{CLR}}$	Q or $\overline{\text{Q}}$	$V_{\text{CC}} = 1.8\text{ V} \pm 0.15\text{ V}$	1		6.9
				$V_{\text{CC}} = 2.5\text{ V} \pm 0.2\text{ V}$	1		4.6

5.11 Switching Characteristics: SN74LVC74A, –40°C to 125°C and –40°C to 85°C

over recommended operating free-air temperature range (unless otherwise noted; see [Parameter Measurement Information](#))

PARAMETER	FROM (INPUT)	TO (OUTPUT)	TEST CONDITIONS		MIN	MAX	UNIT
			T_A	V_{CC}			
f_{max} Maximum clock frequency	—	—	$T_A = -40^\circ\text{C to } 125^\circ\text{C}$	$V_{CC} = 2.7\text{ V}$	83	MHz	
				$V_{CC} = 3.3\text{ V} \pm 0.3\text{ V}$	100		
			$T_A = -40^\circ\text{C to } 85^\circ\text{C and } V_{CC} = 3.3\text{ V} \pm 0.3\text{ V}$	150			
t_{pd} Propagation (delay) time	CLK	Q or \bar{Q}	$T_A = -40^\circ\text{C to } 125^\circ\text{C}$	$V_{CC} = 2.7\text{ V}$	1	6	ns
				$V_{CC} = 3.3\text{ V} \pm 0.3\text{ V}$	1	5.2	
			$T_A = -40^\circ\text{C to } 85^\circ\text{C and } V_{CC} = 3.3\text{ V} \pm 0.3\text{ V}$	1	5.2		
	$T_A = -40^\circ\text{C to } 125^\circ\text{C}$		$V_{CC} = 2.7\text{ V}$	1	6.4		
			$V_{CC} = 3.3\text{ V} \pm 0.3\text{ V}$	1	5.4		
	$T_A = -40^\circ\text{C to } 85^\circ\text{C and } V_{CC} = 3.3\text{ V} \pm 0.3\text{ V}$		1	5.4			
$t_{sk(o)}$ Skew (time), output	—	—	$T_A = -40^\circ\text{C to } 85^\circ\text{C and } V_{CC} = 3.3\text{ V} \pm 0.3\text{ V}$		1	ns	

5.12 Operating Characteristics

$T_A = 25^\circ\text{C}$

PARAMETER	TEST CONDITIONS	TYP	UNIT	
C_{pd} Power dissipation capacitance per flip-flop	$f = 10\text{ MHz}$	$V_{CC} = 1.8\text{ V}$	24	pF
		$V_{CC} = 2.5\text{ V}$	24	
		$V_{CC} = 3.3\text{ V}$	26	

5.13 Typical Characteristics

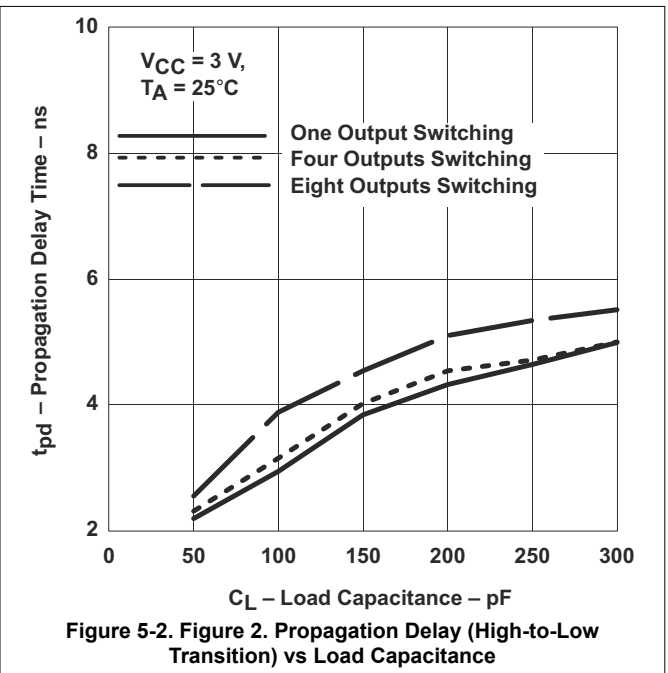
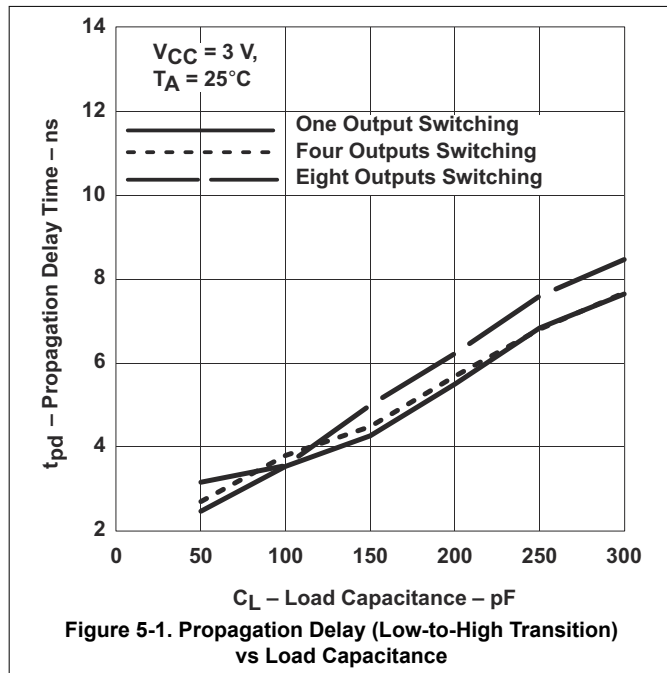

6 Parameter Measurement Information

Phase relationships between waveforms were chosen arbitrarily for the examples listed in the following table. All input pulses are supplied by generators having the following characteristics: $PRR \leq 1\text{MHz}$, $Z_O = 50\Omega$, $t_f \leq 2.5\text{ns}$.

The outputs are measured individually with one input transition per measurement.

V_{CC}	V_t	R_L	C_L	ΔV
$1.8\text{V} \pm 0.15\text{V}$	$V_{CC}/2$	$1\text{k}\Omega$	30pF	0.15V
$2.5\text{V} \pm 0.2\text{V}$	$V_{CC}/2$	500Ω	30pF	0.15V
2.7V	1.5V	500Ω	50pF	0.3V
$3.3\text{V} \pm 0.3\text{V}$	1.5V	500Ω	50pF	0.3V

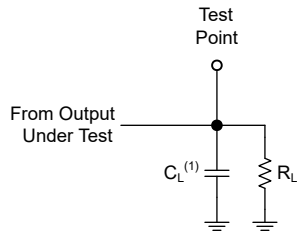

(1) C_L includes probe and test-fixture capacitance.

Figure 6-1. Load Circuit for Push-Pull Outputs

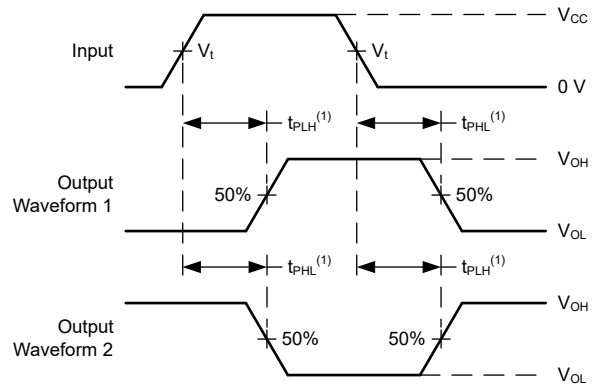

(1) The greater between t_{PLH} and t_{PHL} is the same as t_{pd} .

Figure 6-2. Voltage Waveforms Propagation Delays

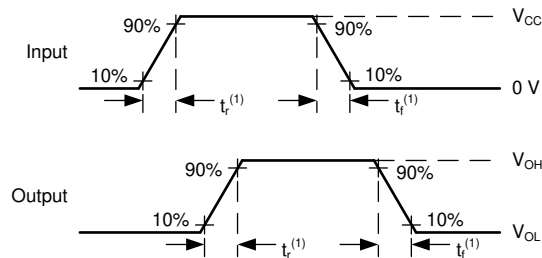

(1) The greater between t_r and t_f is the same as t_t .

Figure 6-3. Voltage Waveforms, Input and Output Transition Times

7 Detailed Description

7.1 Overview

The SNx4LVC74A devices feature two independent positive-edge triggered D flip-flops. Integrated preset ($\overline{\text{PRE}}$) and clear ($\overline{\text{CLR}}$) functions allow for easy setup and control during operation.

The SN54LVC74A device is specified from -55°C to 125°C , and the SN74LVC74A device is specified from -40°C to 125°C .

A low level at the preset ($\overline{\text{PRE}}$) or clear ($\overline{\text{CLR}}$) inputs sets or resets the outputs, regardless of the levels of the other inputs. When $\overline{\text{PRE}}$ and $\overline{\text{CLR}}$ are inactive (high), data at the data (D) input meeting the setup time requirements is transferred to the outputs on the positive-going edge of the clock pulse. Clock triggering occurs at a voltage level and is not directly related to the rise time of the clock pulse. Following the hold-time interval, data at the D input can be changed without affecting the levels at the outputs.

The data I/Os and control inputs are overvoltage tolerant. This feature allows the use of these devices for down-translation in a mixed-voltage environment.

7.2 Functional Block Diagram

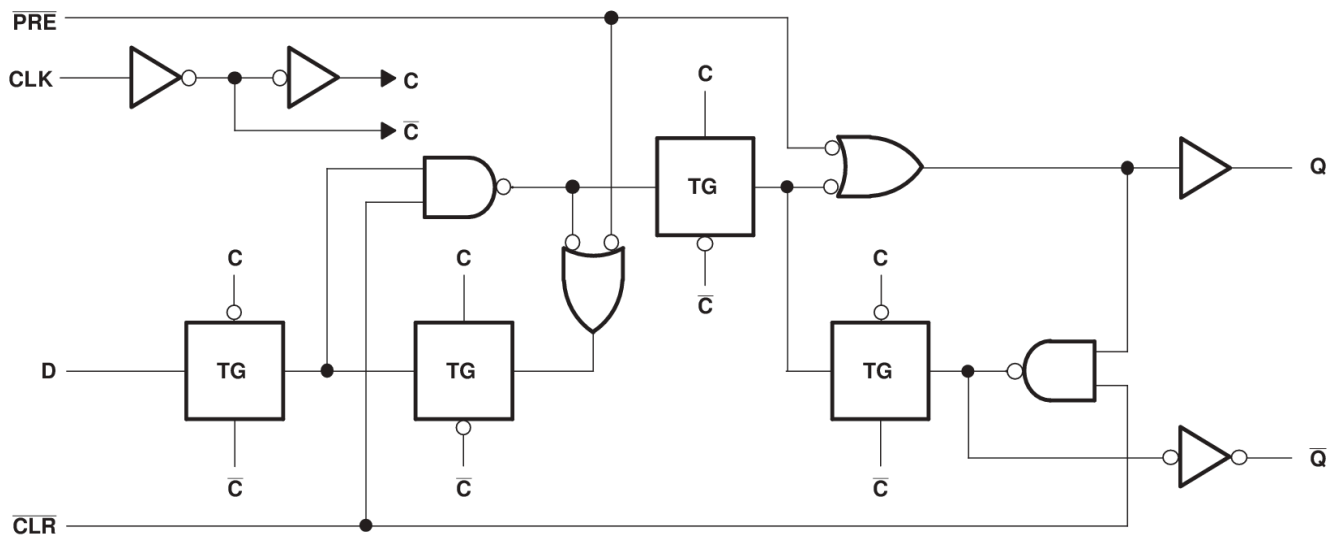

7.3 Feature Description

A low level at the preset ($\overline{\text{PRE}}$) or clear ($\overline{\text{CLR}}$) inputs sets or resets the outputs, regardless of the levels of the other inputs. When $\overline{\text{PRE}}$ and $\overline{\text{CLR}}$ are inactive (high), data at the data (D) input meeting the setup time requirements is transferred to the outputs on the positive-going edge of the clock pulse. Clock triggering occurs at a voltage level and is not directly related to the rise time of the clock pulse. Following the hold-time interval, data at the D input can be changed without affecting the levels at the outputs.

7.4 Device Functional Modes

Table 7-1 describes the SNx4LVC74A functionality and interactions between the $\overline{\text{PRE}}$, $\overline{\text{CLR}}$, CLK, and D inputs.

Table 7-1. Function Table

INPUTS				OUTPUTS	
PRE	CLR	CLK	D	Q	$\overline{\text{Q}}$
L	H	X	X	H	L
H	L	X	X	L	H
L	L	X	X	H ⁽¹⁾	H ⁽¹⁾
H	H	↑	H	H	L

Table 7-1. Function Table (continued)

INPUTS				OUTPUTS	
PRE	CLR	CLK	D	Q	\bar{Q}
H	H	↑	L	L	H
H	H	L	X	Q ₀	\bar{Q} ₀

(1) This configuration is nonstable; that is, it does not persist when PRE or CLR returns to its inactive (high) level.

8 Application and Implementation

Note

Information in the following applications sections is not part of the TI component specification, and TI does not warrant its accuracy or completeness. TI's customers are responsible for determining suitability of components for their purposes. Customers should validate and test their design implementation to confirm system functionality.

8.1 Application Information

A common application for the SN74LVC74A is a frequency divider. By connecting the \bar{Q} output to the D input, the Q output toggles states on each positive edge of the incoming clock signal. Because it takes two positive edges, or two clock pulses, to complete one complete pulse on the output (one pulse to toggle from low to high, another to toggle from high to low), the incoming clock frequency is effectively divided by two.

8.2 Typical Application

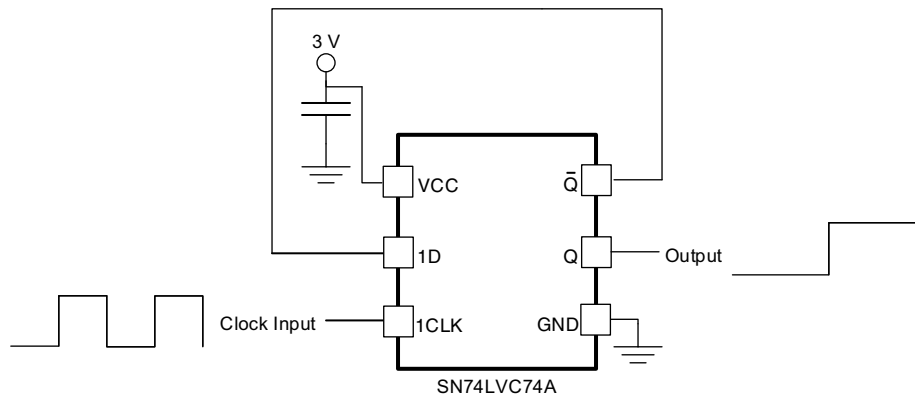

Copyright © 2016, Texas Instruments Incorporated

Figure 8-1. Frequency Divider

8.2.1 Design Requirements

This device uses CMOS technology and has balanced output drive. Avoid bus contention because it can drive currents in excess of maximum limits. The high drive also creates fast edges into light loads, so consider routing and load conditions to prevent ringing.

8.2.2 Detailed Design Procedure

- Recommended input conditions:
 - For rise time and fall time specification, see $(\Delta t/\Delta V)$ in [Recommended Operating Conditions](#).
 - For specified high and low levels, see $(V_{IH}$ and $V_{IL})$ in [Recommended Operating Conditions](#).
 - Inputs are overvoltage tolerant allowing them to go as high as $(V_I \text{ max})$ in [Recommended Operating Conditions](#) at any valid V_{CC} .
- Recommended maximum output conditions:

- Load currents must not exceed (I_O max) per output and must not exceed (Continuous current through V_{CC} or GND) total current for the part. These limits are located in [Absolute Maximum Ratings](#).
- Outputs must not be pulled above V_{CC} .

8.2.3 Application Curves

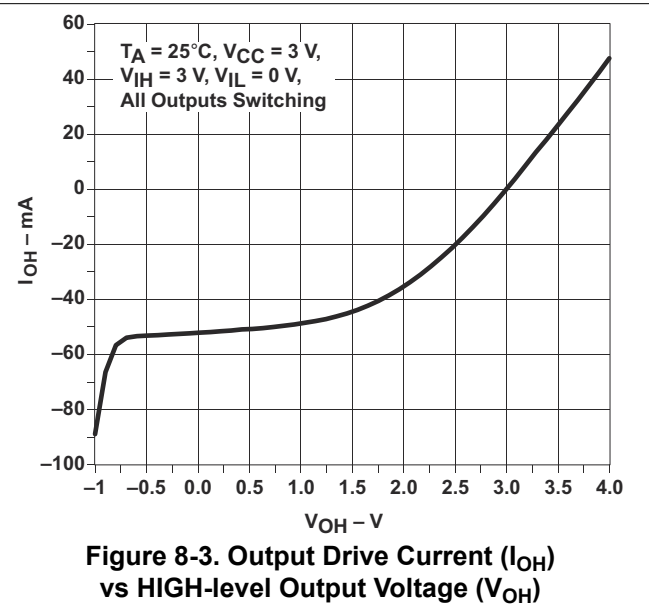
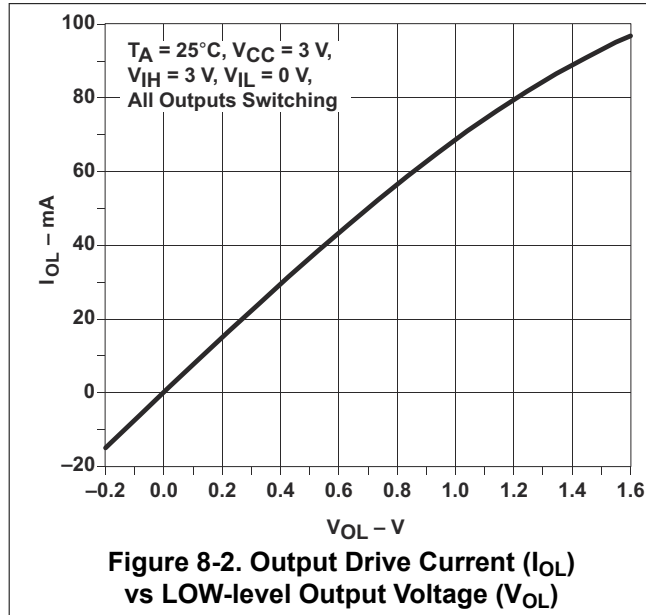

8.3 Power Supply Recommendations

The power supply may be any voltage between the minimum and maximum supply voltage rating located in [Recommended Operating Conditions](#).

Each V_{CC} terminal must have a good bypass capacitor to prevent power disturbance. A 0.1- μ F capacitor is recommended for devices with a single supply. If there are multiple V_{CC} terminals, then 0.01- μ F or 0.022- μ F capacitors are recommended for each power terminal. It is permissible to parallel multiple bypass capacitors to reject different frequencies of noise. Multiple bypass capacitors may be paralleled to reject different frequencies of noise. The bypass capacitor must be installed as close to the power terminal as possible for the best results.

8.4 Layout

8.4.1 Layout Guidelines

Inputs must not float when using multiple bit logic devices. In many cases, functions or parts of functions of digital logic devices are unused. Some examples include situations when only two inputs of a triple-input AND gate are used, or when only 3 of the 4-buffer gates are used. Such input pins must not be left unconnected because the undefined voltages at the outside connections result in undefined operational states.

Specified in [Figure 8-4](#) are rules that must be observed under all circumstances. All unused inputs of digital logic devices must be connected to a high or low bias to prevent them from floating. The logic level that must be applied to any particular unused input depends on the function of the device. Generally, they are tied to GND or V_{CC} , whichever makes more sense or is more convenient.

8.4.2 Layout Example

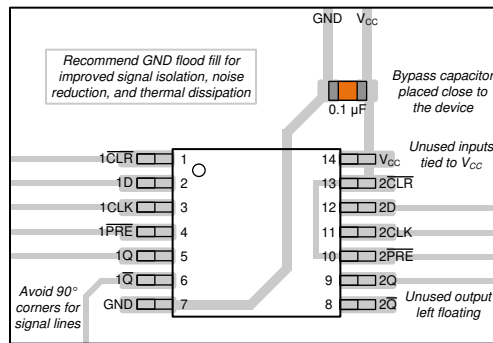

Figure 8-4. Layout Diagram

9 Device and Documentation Support

9.1 Documentation Support

9.1.1 Related Documentation

For related documentation see the following:

[Implications of Slow or Floating CMOS Inputs](#) (SCBA004)

9.2 Receiving Notification of Documentation Updates

To receive notification of documentation updates, navigate to the device product folder on ti.com. Click on *Notifications* to register and receive a weekly digest of any product information that has changed. For change details, review the revision history included in any revised document.

9.3 Support Resources

TI E2E™ support forums are an engineer's go-to source for fast, verified answers and design help — straight from the experts. Search existing answers or ask your own question to get the quick design help you need.

Linked content is provided "AS IS" by the respective contributors. They do not constitute TI specifications and do not necessarily reflect TI's views; see TI's [Terms of Use](#).

9.4 Trademarks

TI E2E™ is a trademark of Texas Instruments.

All trademarks are the property of their respective owners.

9.5 Electrostatic Discharge Caution



This integrated circuit can be damaged by ESD. Texas Instruments recommends that all integrated circuits be handled with appropriate precautions. Failure to observe proper handling and installation procedures can cause damage.

ESD damage can range from subtle performance degradation to complete device failure. Precision integrated circuits may be more susceptible to damage because very small parametric changes could cause the device not to meet its published specifications.

9.6 Glossary

[TI Glossary](#) This glossary lists and explains terms, acronyms, and definitions.

10 Revision History

NOTE: Page numbers for previous revisions may differ from page numbers in the current version.

Changes from Revision U (January 2017) to Revision V (May 2024)	Page
• Updated the numbering format for tables, figures, and cross-references throughout the document.....	1
• Added BQA package to <i>Device Information</i> table, <i>Pin Configuration and Functions</i> section, and <i>Thermal Information</i> table.....	1
• Added package size to <i>Device Information</i> table.....	1

Changes from Revision T (July 2013) to Revision U (January 2017)	Page
• Added <i>ESD Ratings</i> table, <i>Feature Description</i> section, <i>Device Functional Modes, Application and Implementation</i> section, <i>Power Supply Recommendations</i> section, <i>Layout</i> section, <i>Device and Documentation Support</i> section, and <i>Mechanical, Packaging, and Orderable Information</i> section	1
• Changed Package thermal impedance, $R_{\theta JA}$, values in <i>Thermal Information: SN74LVC74A</i> From: 86 To: 93.7 (D), From: 96 To: 107.3 (DB), From: 76 To: 90.3 (NS), From: 113 To: 121.7 (PW), and From: 47 To: 54.9 (RGY).....	5

11 Mechanical, Packaging, and Orderable Information

The following pages include mechanical, packaging, and orderable information. This information is the most current data available for the designated devices. This data is subject to change without notice and revision of this document. For browser-based versions of this data sheet, refer to the left-hand navigation.

PACKAGING INFORMATION

Orderable Device	Status (1)	Package Type	Package Drawing	Pins	Package Qty	Eco Plan (2)	Lead finish/ Ball material (6)	MSL Peak Temp (3)	Op Temp (°C)	Device Marking (4/5)	Samples
5962-9761601Q2A	ACTIVE	LCCC	FK	20	55	Non-RoHS & Green	SNPB	N / A for Pkg Type	-55 to 125	5962-9761601Q2A SNJ54LVC74AFK	Samples
5962-9761601QCA	ACTIVE	CDIP	J	14	25	Non-RoHS & Green	SNPB	N / A for Pkg Type	-55 to 125	5962-9761601QCA SNJ54LVC74AJ	Samples
5962-9761601QDA	ACTIVE	CFP	W	14	25	Non-RoHS & Green	SNPB	N / A for Pkg Type	-55 to 125	5962-9761601QDA SNJ54LVC74AW	Samples
5962-9761601VDA	ACTIVE	CFP	W	14	25	Non-RoHS & Green	SNPB	N / A for Pkg Type	-55 to 125	5962-9761601VDA SNV54LVC74AW	Samples
SN74LVC74ABQAR	ACTIVE	WQFN	BQA	14	3000	RoHS & Green	NIPDAU	Level-1-260C-UNLIM	-40 to 125	LVC74A	Samples
SN74LVC74AD	ACTIVE	SOIC	D	14	50	RoHS & Green	NIPDAU	Level-1-260C-UNLIM	-40 to 125	LVC74A	Samples
SN74LVC74ADBR	ACTIVE	SSOP	DB	14	2000	RoHS & Green	NIPDAU	Level-1-260C-UNLIM	-40 to 125	LC74A	Samples
SN74LVC74ADBRG4	ACTIVE	SSOP	DB	14	2000	RoHS & Green	NIPDAU	Level-1-260C-UNLIM	-40 to 125	LC74A	Samples
SN74LVC74ADR	ACTIVE	SOIC	D	14	2500	RoHS & Green	NIPDAU	Level-1-260C-UNLIM	-40 to 125	LVC74A	Samples
SN74LVC74ADRE4	ACTIVE	SOIC	D	14	2500	RoHS & Green	NIPDAU	Level-1-260C-UNLIM	-40 to 125	LVC74A	Samples
SN74LVC74ADT	ACTIVE	SOIC	D	14	250	RoHS & Green	NIPDAU	Level-1-260C-UNLIM	-40 to 125	LVC74A	Samples
SN74LVC74ANSR	ACTIVE	SO	NS	14	2000	RoHS & Green	NIPDAU	Level-1-260C-UNLIM	-40 to 125	LVC74A	Samples
SN74LVC74APW	ACTIVE	TSSOP	PW	14	90	RoHS & Green	NIPDAU	Level-1-260C-UNLIM	-40 to 125	LC74A	Samples
SN74LVC74APWG4	ACTIVE	TSSOP	PW	14	90	RoHS & Green	NIPDAU	Level-1-260C-UNLIM	-40 to 125	LC74A	Samples
SN74LVC74APWR	ACTIVE	TSSOP	PW	14	2000	RoHS & Green	NIPDAU SN	Level-1-260C-UNLIM	-40 to 125	LC74A	Samples
SN74LVC74APWRE4	ACTIVE	TSSOP	PW	14	2000	RoHS & Green	NIPDAU	Level-1-260C-UNLIM	-40 to 125	LC74A	Samples
SN74LVC74APWRG4	ACTIVE	TSSOP	PW	14	2000	RoHS & Green	NIPDAU	Level-1-260C-UNLIM	-40 to 125	LC74A	Samples

Orderable Device	Status (1)	Package Type	Package Drawing	Pins	Package Qty	Eco Plan (2)	Lead finish/ Ball material (6)	MSL Peak Temp (3)	Op Temp (°C)	Device Marking (4/5)	Samples
SN74LVC74APWT	ACTIVE	TSSOP	PW	14	250	RoHS & Green	NIPDAU	Level-1-260C-UNLIM	-40 to 125	LC74A	Samples
SN74LVC74APWTG4	ACTIVE	TSSOP	PW	14	250	RoHS & Green	NIPDAU	Level-1-260C-UNLIM	-40 to 125	LC74A	Samples
SN74LVC74ARGYR	ACTIVE	VQFN	RGY	14	3000	RoHS & Green	NIPDAU	Level-2-260C-1 YEAR	-40 to 125	LC74A	Samples
SNJ54LVC74AFK	ACTIVE	LCCC	FK	20	55	Non-RoHS & Green	SNPB	N / A for Pkg Type	-55 to 125	5962-9761601Q2A SNJ54LVC74AFK	Samples
SNJ54LVC74AJ	ACTIVE	CDIP	J	14	25	Non-RoHS & Green	SNPB	N / A for Pkg Type	-55 to 125	5962-9761601QC A SNJ54LVC74AJ	Samples
SNJ54LVC74AW	ACTIVE	CFP	W	14	25	Non-RoHS & Green	SNPB	N / A for Pkg Type	-55 to 125	5962-9761601QD A SNJ54LVC74AW	Samples

(1) The marketing status values are defined as follows:

ACTIVE: Product device recommended for new designs.

LIFEBUY: TI has announced that the device will be discontinued, and a lifetime-buy period is in effect.

NRND: Not recommended for new designs. Device is in production to support existing customers, but TI does not recommend using this part in a new design.

PREVIEW: Device has been announced but is not in production. Samples may or may not be available.

OBSELETE: TI has discontinued the production of the device.

(2) **RoHS:** TI defines "RoHS" to mean semiconductor products that are compliant with the current EU RoHS requirements for all 10 RoHS substances, including the requirement that RoHS substance do not exceed 0.1% by weight in homogeneous materials. Where designed to be soldered at high temperatures, "RoHS" products are suitable for use in specified lead-free processes. TI may reference these types of products as "Pb-Free".

RoHS Exempt: TI defines "RoHS Exempt" to mean products that contain lead but are compliant with EU RoHS pursuant to a specific EU RoHS exemption.

Green: TI defines "Green" to mean the content of Chlorine (Cl) and Bromine (Br) based flame retardants meet JS709B low halogen requirements of <=1000ppm threshold. Antimony trioxide based flame retardants must also meet the <=1000ppm threshold requirement.

(3) MSL, Peak Temp. - The Moisture Sensitivity Level rating according to the JEDEC industry standard classifications, and peak solder temperature.

(4) There may be additional marking, which relates to the logo, the lot trace code information, or the environmental category on the device.

(5) Multiple Device Markings will be inside parentheses. Only one Device Marking contained in parentheses and separated by a "~" will appear on a device. If a line is indented then it is a continuation of the previous line and the two combined represent the entire Device Marking for that device.

(6) Lead finish/Ball material - Orderable Devices may have multiple material finish options. Finish options are separated by a vertical ruled line. Lead finish/Ball material values may wrap to two lines if the finish value exceeds the maximum column width.

Important Information and Disclaimer:The information provided on this page represents TI's knowledge and belief as of the date that it is provided. TI bases its knowledge and belief on information provided by third parties, and makes no representation or warranty as to the accuracy of such information. Efforts are underway to better integrate information from third parties. TI has taken and continues to take reasonable steps to provide representative and accurate information but may not have conducted destructive testing or chemical analysis on incoming materials and chemicals. TI and TI suppliers consider certain information to be proprietary, and thus CAS numbers and other limited information may not be available for release.

In no event shall TI's liability arising out of such information exceed the total purchase price of the TI part(s) at issue in this document sold by TI to Customer on an annual basis.

OTHER QUALIFIED VERSIONS OF SN54LVC74A, SN54LVC74A-SP, SN74LVC74A :

- Catalog : [SN74LVC74A](#), [SN54LVC74A](#)
- Automotive : [SN74LVC74A-Q1](#), [SN74LVC74A-Q1](#)
- Enhanced Product : [SN74LVC74A-EP](#), [SN74LVC74A-EP](#)
- Military : [SN54LVC74A](#)
- Space : [SN54LVC74A-SP](#)

NOTE: Qualified Version Definitions:

- Catalog - TI's standard catalog product
- Automotive - Q100 devices qualified for high-reliability automotive applications targeting zero defects
- Enhanced Product - Supports Defense, Aerospace and Medical Applications
- Military - QML certified for Military and Defense Applications
- Space - Radiation tolerant, ceramic packaging and qualified for use in Space-based application

TAPE AND REEL INFORMATION

QUADRANT ASSIGNMENTS FOR PIN 1 ORIENTATION IN TAPE

*All dimensions are nominal

Device	Package Type	Package Drawing	Pins	SPQ	Reel Diameter (mm)	Reel Width W1 (mm)	A0 (mm)	B0 (mm)	K0 (mm)	P1 (mm)	W (mm)	Pin1 Quadrant
SN74LVC74ABQAR	WQFN	BQA	14	3000	180.0	12.4	2.8	3.3	1.1	4.0	12.0	Q1
SN74LVC74ADBR	SSOP	DB	14	2000	330.0	16.4	8.35	6.6	2.4	12.0	16.0	Q1
SN74LVC74ADR	SOIC	D	14	2500	330.0	16.4	6.5	9.0	2.1	8.0	16.0	Q1
SN74LVC74ADT	SOIC	D	14	250	330.0	16.4	6.5	9.0	2.1	8.0	16.0	Q1
SN74LVC74ANSR	SO	NS	14	2000	330.0	16.4	8.2	10.5	2.5	12.0	16.0	Q1
SN74LVC74APWR	TSSOP	PW	14	2000	330.0	12.4	6.9	5.6	1.6	8.0	12.0	Q1
SN74LVC74APWR	TSSOP	PW	14	2000	330.0	12.4	6.9	5.6	1.6	8.0	12.0	Q1
SN74LVC74APWRG4	TSSOP	PW	14	2000	330.0	12.4	6.9	5.6	1.6	8.0	12.0	Q1
SN74LVC74APWT	TSSOP	PW	14	250	330.0	12.4	6.9	5.6	1.6	8.0	12.0	Q1
SN74LVC74ARGYR	VQFN	RGY	14	3000	330.0	12.4	3.75	3.75	1.15	8.0	12.0	Q1

TAPE AND REEL BOX DIMENSIONS

*All dimensions are nominal

Device	Package Type	Package Drawing	Pins	SPQ	Length (mm)	Width (mm)	Height (mm)
SN74LVC74ABQAR	WQFN	BQA	14	3000	210.0	185.0	35.0
SN74LVC74ADBR	SSOP	DB	14	2000	356.0	356.0	35.0
SN74LVC74ADR	SOIC	D	14	2500	356.0	356.0	35.0
SN74LVC74ADT	SOIC	D	14	250	210.0	185.0	35.0
SN74LVC74ANSR	SO	NS	14	2000	356.0	356.0	35.0
SN74LVC74APWR	TSSOP	PW	14	2000	356.0	356.0	35.0
SN74LVC74APWR	TSSOP	PW	14	2000	364.0	364.0	27.0
SN74LVC74APWRG4	TSSOP	PW	14	2000	356.0	356.0	35.0
SN74LVC74APWT	TSSOP	PW	14	250	356.0	356.0	35.0
SN74LVC74ARGYR	VQFN	RGY	14	3000	356.0	356.0	35.0

TUBE

*All dimensions are nominal

Device	Package Name	Package Type	Pins	SPQ	L (mm)	W (mm)	T (μm)	B (mm)
5962-9761601Q2A	FK	LCCC	20	55	506.98	12.06	2030	NA
5962-9761601VDA	W	CFP	14	25	506.98	26.16	6220	NA
SN74LVC74AD	D	SOIC	14	50	506.6	8	3940	4.32
SN74LVC74APW	PW	TSSOP	14	90	530	10.2	3600	3.5
SN74LVC74APWG4	PW	TSSOP	14	90	530	10.2	3600	3.5
SNJ54LVC74AFK	FK	LCCC	20	55	506.98	12.06	2030	NA

RGY (S-PVQFN-N14)

PLASTIC QUAD FLATPACK NO-LEAD

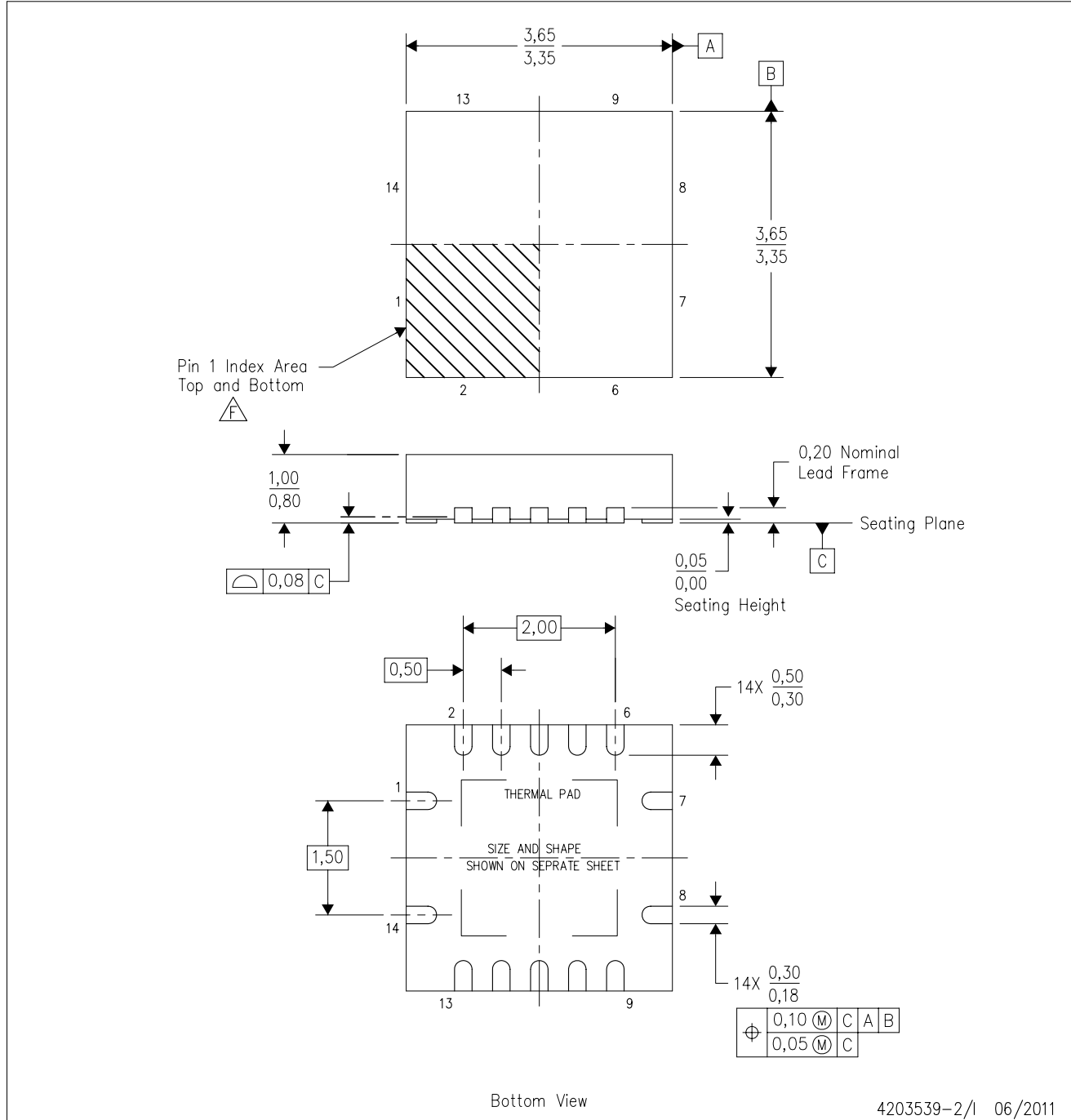

- NOTES:
- All linear dimensions are in millimeters. Dimensioning and tolerancing per ASME Y14.5M-1994.
 - This drawing is subject to change without notice.
 - QFN (Quad Flatpack No-Lead) package configuration.
 - The package thermal pad must be soldered to the board for thermal and mechanical performance.
 - See the additional figure in the Product Data Sheet for details regarding the exposed thermal pad features and dimensions.
 - Pin 1 identifiers are located on both top and bottom of the package and within the zone indicated. The Pin 1 identifiers are either a molded, marked, or metal feature.
 - Package complies to JEDEC MO-241 variation BA.

RGY (S-PVQFN-N14)

PLASTIC QUAD FLATPACK NO-LEAD

THERMAL INFORMATION

This package incorporates an exposed thermal pad that is designed to be attached directly to an external heatsink. The thermal pad must be soldered directly to the printed circuit board (PCB). After soldering, the PCB can be used as a heatsink. In addition, through the use of thermal vias, the thermal pad can be attached directly to the appropriate copper plane shown in the electrical schematic for the device, or alternatively, can be attached to a special heatsink structure designed into the PCB. This design optimizes the heat transfer from the integrated circuit (IC).

For information on the Quad Flatpack No-Lead (QFN) package and its advantages, refer to Application Report, QFN/SON PCB Attachment, Texas Instruments Literature No. SLUA271. This document is available at www.ti.com.

The exposed thermal pad dimensions for this package are shown in the following illustration.

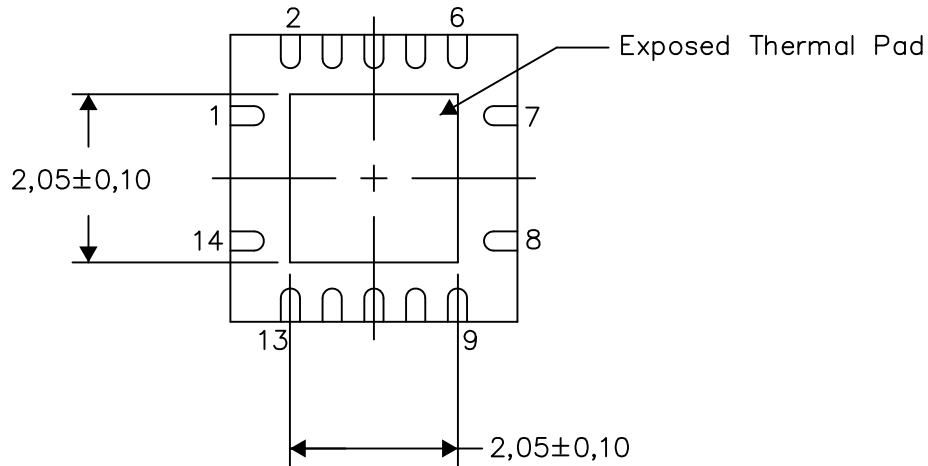

Bottom View

Exposed Thermal Pad Dimensions

4206353-2/P 03/14

NOTE: All linear dimensions are in millimeters

RGY (S-PVQFN-N14)

PLASTIC QUAD FLATPACK NO-LEAD



4208122-2/P 03/14

- NOTES:
- All linear dimensions are in millimeters.
 - This drawing is subject to change without notice.
 - Publication IPC-7351 is recommended for alternate designs.
 - This package is designed to be soldered to a thermal pad on the board. Refer to Application Note, Quad Flat-Pack QFN/SON PCB Attachment, Texas Instruments Literature No. SLUA271, and also the Product Data Sheets for specific thermal information, via requirements, and recommended board layout. These documents are available at www.ti.com <<http://www.ti.com>>.
 - Laser cutting apertures with trapezoidal walls and also rounding corners will offer better paste release. Customers should contact their board assembly site for stencil design recommendations. Refer to IPC 7525 for stencil design considerations.
 - Customers should contact their board fabrication site for minimum solder mask web tolerances between signal pads.

GENERIC PACKAGE VIEW

BQA 14

WQFN - 0.8 mm max height

2.5 x 3, 0.5 mm pitch

PLASTIC QUAD FLATPACK - NO LEAD

This image is a representation of the package family, actual package may vary.
Refer to the product data sheet for package details.

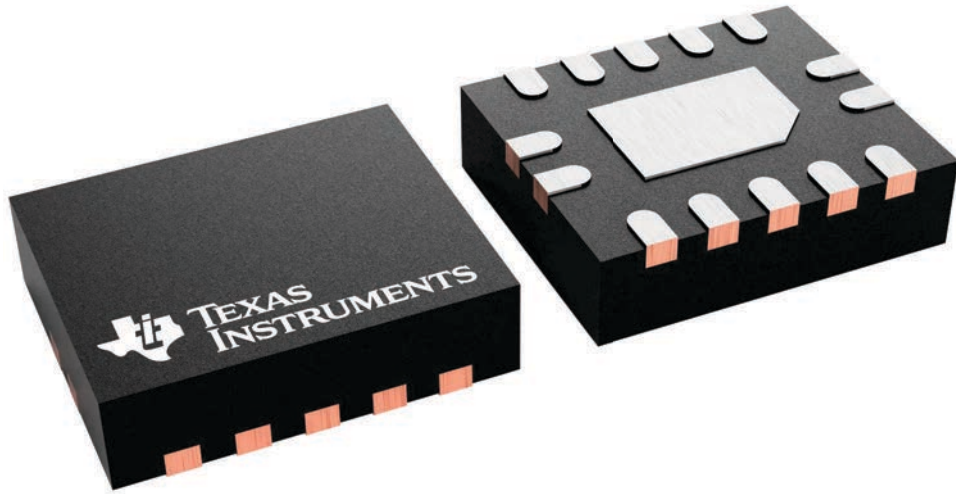

EXAMPLE BOARD LAYOUT

WQFN - 0.8 mm max height

BQA0014A

PLASTIC QUAD FLAT PACK-NO LEAD



LAND PATTERN EXAMPLE
EXPOSED METAL SHOWN
SCALE: 20X

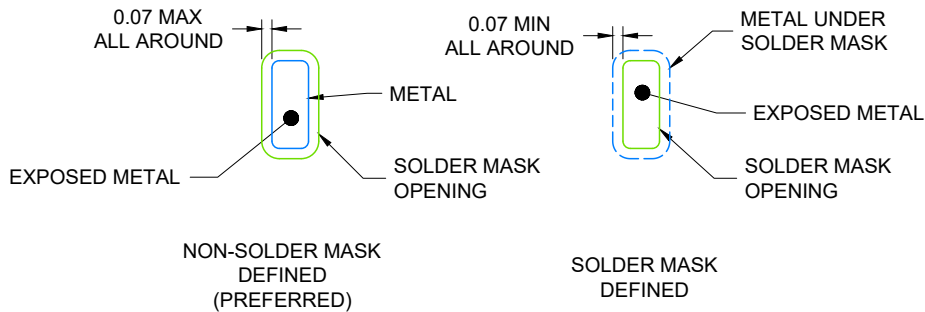

4224636/A 11/2018

NOTES: (continued)

4. This package is designed to be soldered to a thermal pad on the board. For more information, see Texas Instruments literature number SLUA271 (www.ti.com/lit/slua271).
5. Vias are optional depending on application, refer to device data sheet. If any vias are implemented, refer to their locations shown on this view. It is recommended that vias under paste be filled, plugged or tented.

EXAMPLE STENCIL DESIGN

BQA0014A

WQFN - 0.8 mm max height

PLASTIC QUAD FLAT PACK-NO LEAD



SOLDER PASTE EXAMPLE
 BASED ON 0.125 mm THICK STENCIL

EXPOSED PAD
 88% PRINTED COVERAGE BY AREA
 SCALE: 20X

4224636/A 11/2018

NOTES: (continued)

- 6. Laser cutting apertures with trapezoidal walls and rounded corners may offer better paste release. IPC-7525 may have alternate design recommendations.

MECHANICAL DATA

NS (R-PDSO-G**)

PLASTIC SMALL-OUTLINE PACKAGE

14-PINS SHOWN



- NOTES:
- A. All linear dimensions are in millimeters.
 - B. This drawing is subject to change without notice.
 - C. Body dimensions do not include mold flash or protrusion, not to exceed 0,15.

W (R-GDFP-F14)

CERAMIC DUAL FLATPACK

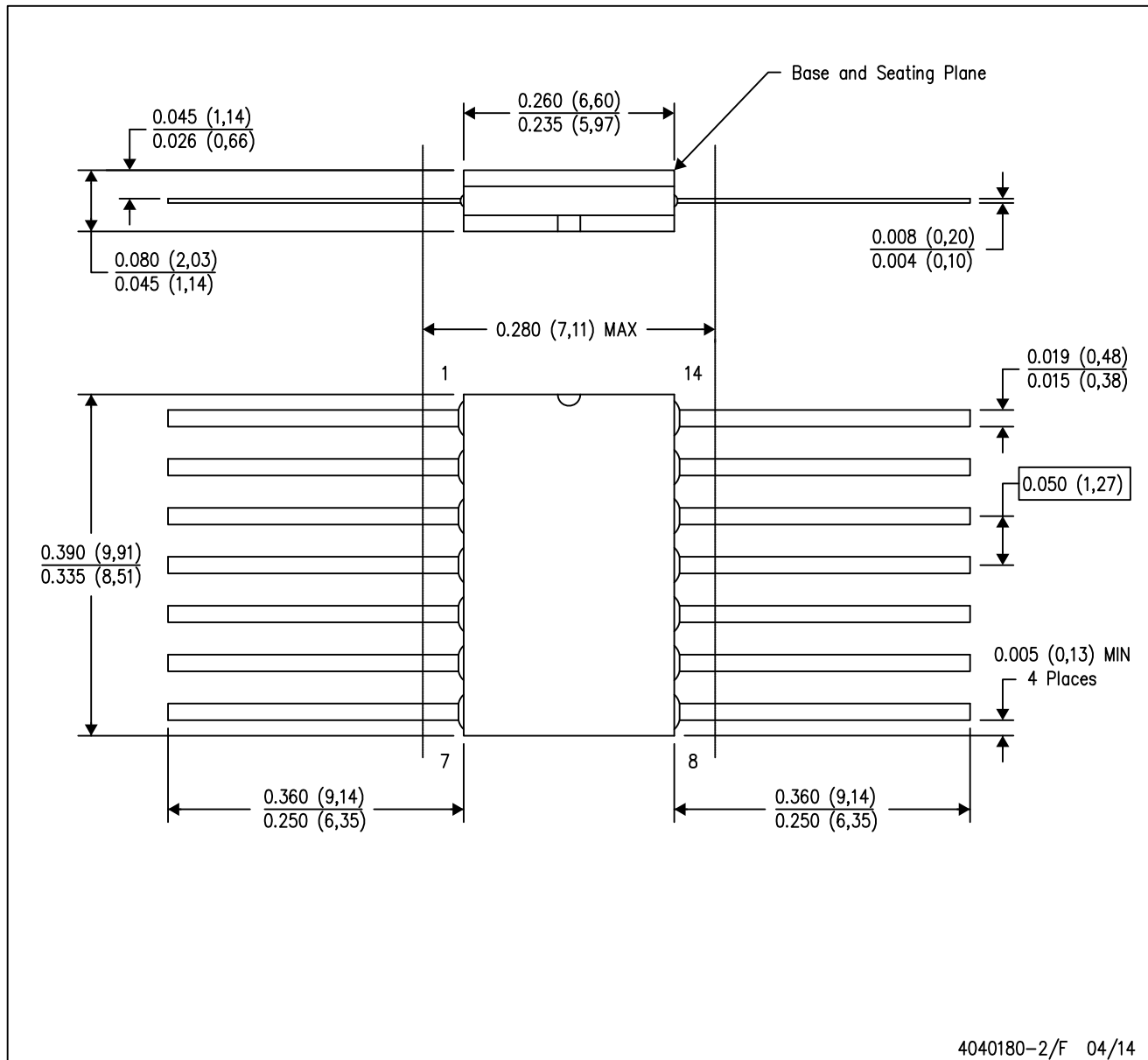

4040180-2/F 04/14

- NOTES:
- A. All linear dimensions are in inches (millimeters).
 - B. This drawing is subject to change without notice.
 - C. This package can be hermetically sealed with a ceramic lid using glass frit.
 - D. Index point is provided on cap for terminal identification only.
 - E. Falls within MIL STD 1835 GDFP1-F14

GENERIC PACKAGE VIEW

FK 20

LCCC - 2.03 mm max height

8.89 x 8.89, 1.27 mm pitch

LEADLESS CERAMIC CHIP CARRIER

This image is a representation of the package family, actual package may vary.
Refer to the product data sheet for package details.



4229370VA\

J 14

GENERIC PACKAGE VIEW
CDIP - 5.08 mm max height
CERAMIC DUAL IN LINE PACKAGE

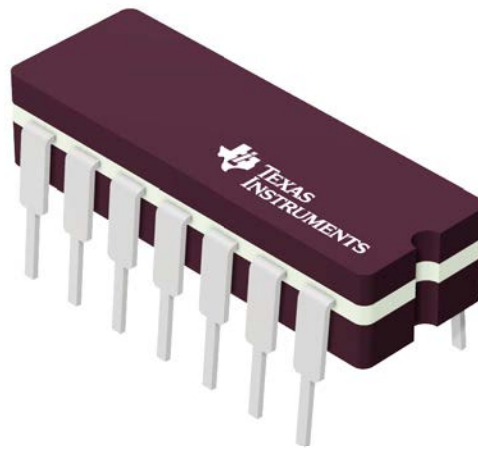

Images above are just a representation of the package family, actual package may vary.
Refer to the product data sheet for package details.

4040083-5/G

J0014A



PACKAGE OUTLINE

CDIP - 5.08 mm max height

CERAMIC DUAL IN LINE PACKAGE

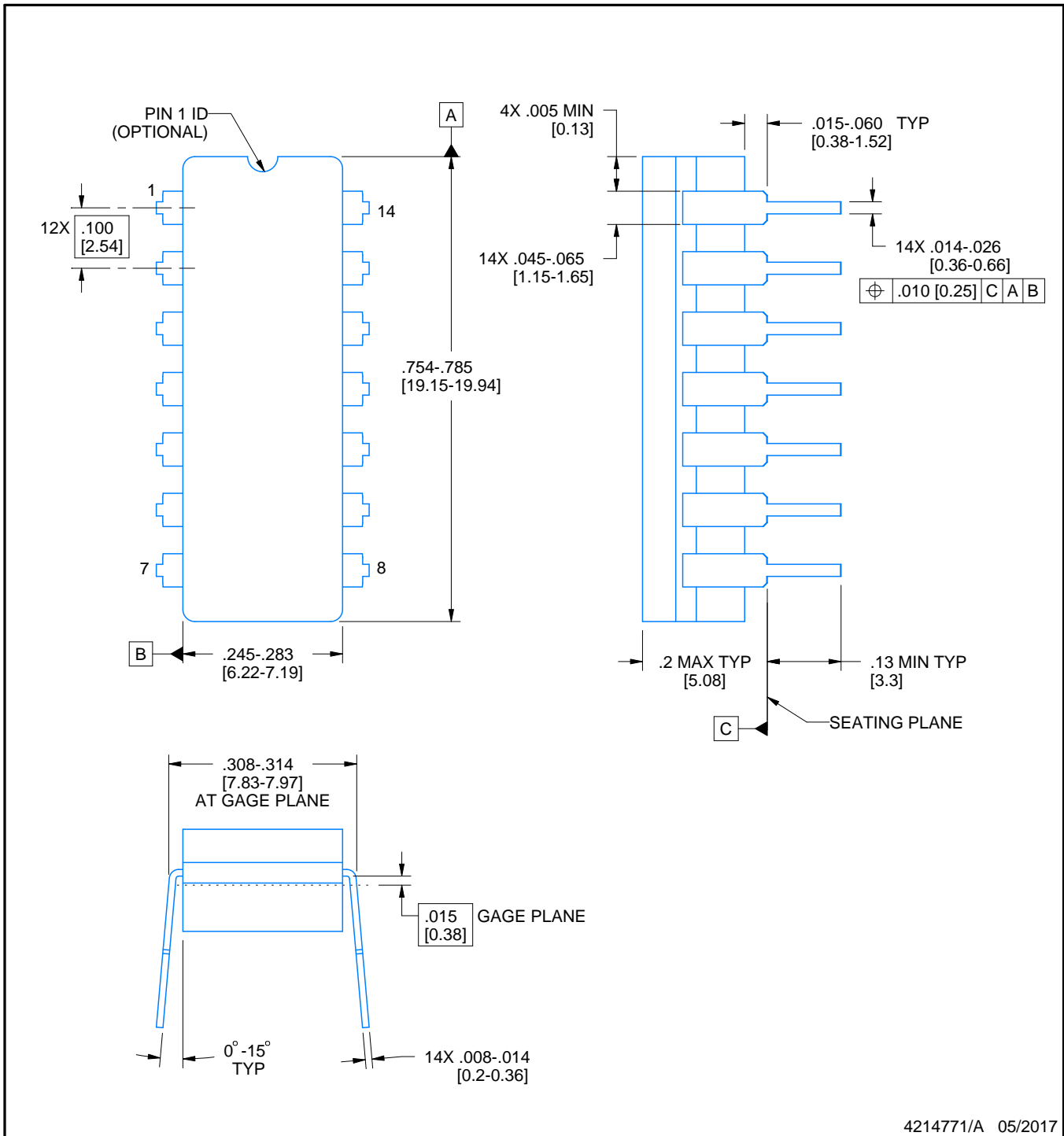

4214771/A 05/2017

NOTES:

1. All controlling linear dimensions are in inches. Dimensions in brackets are in millimeters. Any dimension in brackets or parenthesis are for reference only. Dimensioning and tolerancing per ASME Y14.5M.
2. This drawing is subject to change without notice.
3. This package is hermetically sealed with a ceramic lid using glass frit.
4. Index point is provided on cap for terminal identification only and on press ceramic glass frit seal only.
5. Falls within MIL-STD-1835 and GDIP1-T14.

EXAMPLE BOARD LAYOUT

J0014A

CDIP - 5.08 mm max height

CERAMIC DUAL IN LINE PACKAGE



LAND PATTERN EXAMPLE
NON-SOLDER MASK DEFINED
SCALE: 5X

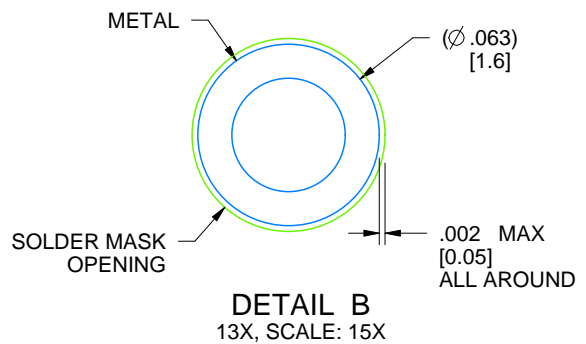

4214771/A 05/2017

D (R-PDSO-G14)

PLASTIC SMALL OUTLINE



- NOTES:
- A. All linear dimensions are in inches (millimeters).
 - B. This drawing is subject to change without notice.
 -  Body length does not include mold flash, protrusions, or gate burrs. Mold flash, protrusions, or gate burrs shall not exceed 0.006 (0,15) each side.
 -  Body width does not include interlead flash. Interlead flash shall not exceed 0.017 (0,43) each side.
 - E. Reference JEDEC MS-012 variation AB.

D (R-PDSO-G14)

PLASTIC SMALL OUTLINE



- NOTES:
- A. All linear dimensions are in millimeters.
 - B. This drawing is subject to change without notice.
 - C. Publication IPC-7351 is recommended for alternate designs.
 - D. Laser cutting apertures with trapezoidal walls and also rounding corners will offer better paste release. Customers should contact their board assembly site for stencil design recommendations. Refer to IPC-7525 for other stencil recommendations.
 - E. Customers should contact their board fabrication site for solder mask tolerances between and around signal pads.

PW (R-PDSO-G14)

PLASTIC SMALL OUTLINE



- NOTES:
- A. All linear dimensions are in millimeters. Dimensioning and tolerancing per ASME Y14.5M-1994.
 - B. This drawing is subject to change without notice.
 - C. Body length does not include mold flash, protrusions, or gate burrs. Mold flash, protrusions, or gate burrs shall not exceed 0,15 each side.
 - D. Body width does not include interlead flash. Interlead flash shall not exceed 0,25 each side.
 - E. Falls within JEDEC MO-153

PW (R-PDSO-G14)

PLASTIC SMALL OUTLINE



4211284-2/G 08/15

- NOTES:
- All linear dimensions are in millimeters.
 - This drawing is subject to change without notice.
 - Publication IPC-7351 is recommended for alternate designs.
 - Laser cutting apertures with trapezoidal walls and also rounding corners will offer better paste release. Customers should contact their board assembly site for stencil design recommendations. Refer to IPC-7525 for other stencil recommendations.
 - Customers should contact their board fabrication site for solder mask tolerances between and around signal pads.

DB (R-PDSO-G**)

PLASTIC SMALL-OUTLINE

28 PINS SHOWN

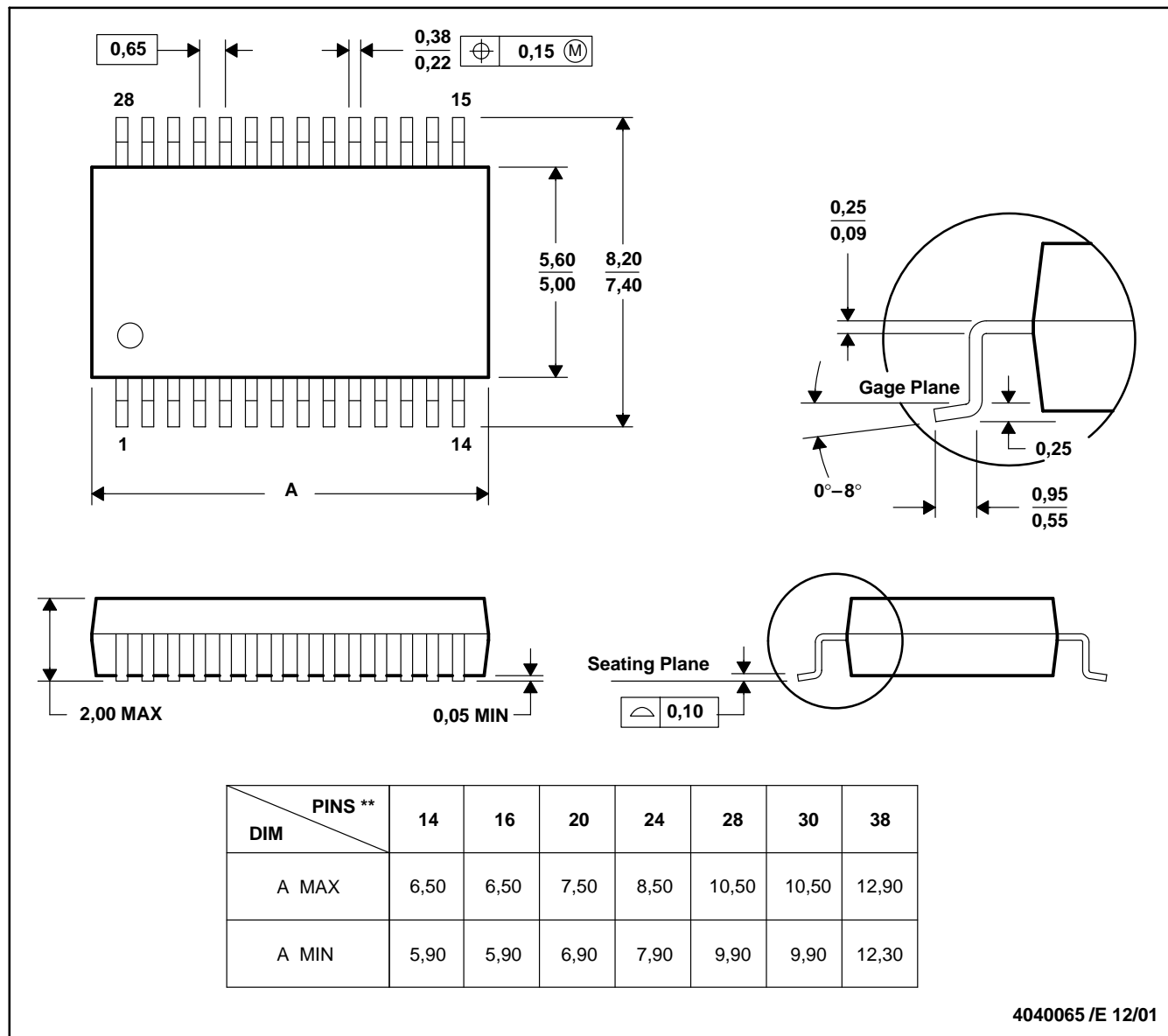

- NOTES: A. All linear dimensions are in millimeters.
 B. This drawing is subject to change without notice.
 C. Body dimensions do not include mold flash or protrusion not to exceed 0,15.
 D. Falls within JEDEC MO-150

IMPORTANT NOTICE AND DISCLAIMER

TI PROVIDES TECHNICAL AND RELIABILITY DATA (INCLUDING DATA SHEETS), DESIGN RESOURCES (INCLUDING REFERENCE DESIGNS), APPLICATION OR OTHER DESIGN ADVICE, WEB TOOLS, SAFETY INFORMATION, AND OTHER RESOURCES "AS IS" AND WITH ALL FAULTS, AND DISCLAIMS ALL WARRANTIES, EXPRESS AND IMPLIED, INCLUDING WITHOUT LIMITATION ANY IMPLIED WARRANTIES OF MERCHANTABILITY, FITNESS FOR A PARTICULAR PURPOSE OR NON-INFRINGEMENT OF THIRD PARTY INTELLECTUAL PROPERTY RIGHTS.

These resources are intended for skilled developers designing with TI products. You are solely responsible for (1) selecting the appropriate TI products for your application, (2) designing, validating and testing your application, and (3) ensuring your application meets applicable standards, and any other safety, security, regulatory or other requirements.

These resources are subject to change without notice. TI grants you permission to use these resources only for development of an application that uses the TI products described in the resource. Other reproduction and display of these resources is prohibited. No license is granted to any other TI intellectual property right or to any third party intellectual property right. TI disclaims responsibility for, and you will fully indemnify TI and its representatives against, any claims, damages, costs, losses, and liabilities arising out of your use of these resources.

TI's products are provided subject to [TI's Terms of Sale](#) or other applicable terms available either on [ti.com](https://www.ti.com) or provided in conjunction with such TI products. TI's provision of these resources does not expand or otherwise alter TI's applicable warranties or warranty disclaimers for TI products.

TI objects to and rejects any additional or different terms you may have proposed.

Mailing Address: Texas Instruments, Post Office Box 655303, Dallas, Texas 75265
Copyright © 2024, Texas Instruments Incorporated

Looking for pricing, stock, or lifecycle information?

Click below to explore more details on WIN SOURCE:

 [View SN74LVC74ADBRG4 on WIN SOURCE](#)

 [Texas Instruments](#) Information

Optimize Your Supply Chain with WIN SOURCE Solutions

-  Global Sourcing Solution
-  Obsolete Management
-  Cost Control Management
-  Shortage Management
-  Alternative Solution
-  Excess Inventory Management