



# THE DATASHEET OF MAX4591CSE





# High-Speed, Single-Supply, Quad, SPST Analog Switches

MAX4591/MAX4592/MAX4593

## General Description

The MAX4591/MAX4592/MAX4593 are high-speed, precision, quad, single-pole/single-throw (SPST) analog switches designed to operate at +12V or +15V. The MAX4591 has four normally closed (NC) switches, and the MAX4592 has four normally open (NO) switches. The MAX4593 has two NO and two NC switches. All three devices offer low leakage (100pA max) and fast switching speeds ( $t_{ON} \leq 80ns$ ,  $t_{OFF} \leq 45ns$ ).

With a +12V supply, the MAX4591/MAX4592/MAX4593 offer guaranteed  $1\Omega$  max channel-to-channel matching,  $20\Omega$  max on-resistance ( $R_{ON}$ ), and  $1.75\Omega$  max  $R_{ON}$  flatness over the specified range.

These switches are also fully specified for single +15V operation, with  $16\Omega$  max  $R_{ON}$ ,  $1.5\Omega$  max  $R_{ON}$  match, and  $1.5\Omega$  max flatness. For low-voltage or dual-supply operation, refer to the MAX391 data sheet.

These low-voltage switches also offer 5pC max charge injection, and electrostatic discharge (ESD) protection is greater than 2000V, per Method 3015.7.

## Applications

Test Equipment	Sample-and-Hold Circuits
Disk Drives	Guidance and Control Systems
Tape Drives	Military Radios
Audio and Video	Communications Systems
Switching	PBX, PABX
Heads-Up Displays	

## Features

- ◆ Low  $16\Omega$  On-Resistance
- ◆ Fast Switching Times:  $t_{ON} = 50ns$ ,  $t_{OFF} = 30ns$
- ◆ Guaranteed  $1\Omega$  max On-Resistance Match Between Channels
- ◆ Guaranteed  $1.75\Omega$  max On-Resistance Flatness over Signal Range
- ◆ Guaranteed 5pC max Charge Injection
- ◆ Improved Leakage over Temperature: 5nA max at +85°C
- ◆ ESD >2000V per Method 3015.7
- ◆ +12V or +15V Single-Supply Operation
- ◆ Pin Compatible with DG611/DG612/DG613, DG211/DG212/DG213

## Ordering Information

PART	TEMP. RANGE	PIN-PACKAGE
MAX4591CUE	0°C to +70°C	16 TSSOP
MAX4591CSE	0°C to +70°C	16 Narrow SO
MAX4591CPE	0°C to +70°C	16 Plastic DIP
MAX4591EUE	-40°C to +85°C	16 TSSOP
MAX4591ESE	-40°C to +85°C	16 Narrow SO
MAX4591EPE	-40°C to +85°C	16 Plastic DIP

Ordering Information continued at end of data sheet.

## Pin Configurations/Functional Diagrams/Truth Tables

TOP VIEW

**TSSOP/SO/DIP**

MAX4591	
LOGIC	SWITCH
0	ON
1	OFF

N.C. = NO CONNECTION

**TSSOP/SO/DIP**

MAX4592	
LOGIC	SWITCH
0	OFF
1	ON

SWITCHES SHOWN FOR LOGIC "0" INPUT

**TSSOP/SO/DIP**

MAX4593		
LOGIC	SWITCHES 1, 4	SWITCHES 2, 3
0	OFF	ON
1	ON	OFF



# High-Speed, Single-Supply, Quad, SPST Analog Switches

## ABSOLUTE MAXIMUM RATINGS

V+ to GND .....	-0.3V to +17V
VIN_, VCOM_, VNC_, VNO_ (Note 1) .....	V- to V+
Current (any terminal) .....	30mA
Peak Current, COM_, NO_, NC_ (pulsed at 1ms, 10% duty cycle max) .....	100mA
ESD per Method 3015.7 .....	>2000V
Continuous Power Dissipation (TA = +70°C) 16-Pin TSSOP (derate 5.70mW/°C above +70°C) .....	457mW

16-Pin Narrow SO (derate 8.70mW/°C above +70°C) .....	696mW
16-Pin Plastic DIP (derate 10.53mW/°C above +70°C) .....	842mW
Operating Temperature Ranges	
MAX459_C_E .....	0°C to +70°C
MAX459_E_E .....	-40°C to +85°C
Storage Temperature Range .....	-65°C to +150°C
Lead Temperature (soldering, 10s) .....	+300°C

**Note 1:** Signals on NC\_, NO\_, COM\_, or IN\_ exceeding V+ or V- are clamped by internal diodes. Limit forward diode current to maximum current rating.

Stresses beyond those listed under "Absolute Maximum Ratings" may cause permanent damage to the device. These are stress ratings only, and functional operation of the device at these or any other conditions beyond those indicated in the operational sections of the specifications is not implied. Exposure to absolute maximum rating conditions for extended periods may affect device reliability.

## ELECTRICAL CHARACTERISTICS—Single +12V Supply

(V+ = +12V, V- = GND = 0, VINH = 5V, VINL = 0.8V, TA = TMIN to TMAX, unless otherwise noted. Typical values are at TA = +25°C.) (Note 2)

PARAMETER	SYMBOL	CONDITIONS	MIN	TYP	MAX	UNITS
<b>ANALOG SWITCH</b>						
Analog Signal Range	VCOM_, VNO_, VNC_	(Note 3)	C, E	V-	V+	V
On-Resistance	RON	ICOM_ = -10mA, VNO_ or VNC_ = 10V	TA = +25°C C, E	16	20 24	Ω
On-Resistance Match Between Channels (Note 4)	ΔRON	ICOM_ = -10mA, VNO_ or VNC_ = 10V	TA = +25°C C, E	0.5	1 1.5	Ω
On-Resistance Flatness (Note 5)	RFLAT(ON)	ICOM_ = -10mA; VNO_ or VNC_ = 3V, 6V, 9V	TA = +25°C C, E	1	1.75 2	Ω
NO or NC Off-Leakage Current (Note 6)	INO_(OFF) or INC_(OFF)	V+ = 15.5V; VCOM_ = 14V, 1V; VNO_ or VNC_ = 1V, 14V	TA = +25°C C, E	-0.1	0.01 5	0.1 nA
COM Off-Leakage Current (Note 6)	ICOM_(OFF)	V+ = 15.5V; VCOM_ = 14V, 1V; VNO_ or VNC_ = 1V, 14V	TA = +25°C C, E	-0.1	0.01 5	0.1 nA
COM On-Leakage Current (Note 6)	ICOM_(ON)	V+ = 15.5V; VCOM_ = 14V, 1V; VNO_ or VNC_ = 14V, 1V, or floating	TA = +25°C C, E	-0.2	0.01 10	0.2 nA

# High-Speed, Single-Supply, Quad, SPST Analog Switches

MAX4591/MAX4592/MAX4593

## ELECTRICAL CHARACTERISTICS—Single +12V Supply (continued)

(V+ = +12V, V- = GND = 0, VINH = 5V, VINL = 0.8V, TA = TMIN to TMAX, unless otherwise noted. Typical values are at TA = +25°C.) (Note 2)

PARAMETER	SYMBOL	CONDITIONS		MIN	TYP	MAX	UNITS
<b>LOGIC INPUT</b>							
Input Current with Input Voltage High	IINH	IN_ = V+, all others = 0.8V		-0.5	0.005	0.5	μA
Input Current with Input Voltage Low	IINL	IN_ = 0.8V, all others = V+		-0.5	0.005	0.5	μA
<b>DYNAMIC</b>							
Turn-On Time	tON	VCOM_ = 10V, Figure 2	TA = +25°C	50	80		ns
			C, E		90		
Turn-Off Time	tOFF	VCOM_ = 10V, Figure 2	TA = +25°C	30	45		ns
			C, E		50		
Break-Before-Make Time Delay (Note 3)	tD	MAX4593 only, RL = 300Ω, CL = 35pF, Figure 3		5	20		ns
Charge Injection (Note 3)	Q	CL = 1nF, VGEN = 0, RGEN = 0Ω, Figure 4	TA = +25°C		2	5	pC
Off-Isolation (Note 7)	OIRR	RL = 50Ω, CL = 5pF, f = 10MHz, Figure 5	TA = +25°C		72		dB
Crosstalk (Note 8)		RL = 50Ω, CL = 5pF, f = 10MHz, Figure 6	TA = +25°C		85		dB
NC_ or NO_ Capacitance	C(OFF)	f = 1MHz, Figure 7	TA = +25°C		9		pF
COM_ Off-Capacitance	CCOM_(OFF)	f = 1MHz, Figure 7	TA = +25°C		9		pF
COM_ On-Capacitance	CCOM_(ON)	f = 1MHz, Figure 8	TA = +25°C		22		pF
<b>SUPPLY</b>							
Power-Supply Range				3		16	V
Positive Supply Current	I+	V+ = 15V, VINL = 0 or V+, all channels on or off	C, E	-1	0.001	1	μA

# High-Speed, Single-Supply, Quad, SPST Analog Switches

## ELECTRICAL CHARACTERISTICS—Single +15V Supply

(V+ = +15V, V- = GND = 0, VINH = 5V, VINL = 0.8V, TA = TMIN to TMAX, unless otherwise noted. Typical values are at TA = +25°C.) (Note 2)

PARAMETER	SYMBOL	CONDITIONS	MIN	TYP	MAX	UNITS	
<b>ANALOG SWITCH</b>							
Analog Signal Range	VCOM-, VNO-, VNC-	(Note 3)	0		V+	V	
On-Resistance	RON	ICOM- = -10mA, VNO- or VNC- = 10V	TA = +25°C	12	16	Ω	
			C, E		2.0		
On-Resistance Match Between Channels (Notes 3, 4)	ΔRON	ICOM- = -10mA, VNO- or VNC- = 10V	TA = +25°C	0.5	1.5	Ω	
			C, E		2.0		
On-Resistance Flatness (Notes 3, 5)	RFLAT(ON)	ICOM- = -10mA; VNO- or VNC- = 3V, 6V, 9V	TA = +25°C	0.7	1.5	Ω	
			C, E		2.0		
NO- or NC- Off-Leakage Current (Note 6)	INO-(OFF) or INC-(OFF)	V+ = 15.5V; VCOM- = 14V, 1V; VNO- or VNC- = 1V, 14V	TA = +25°C	-0.1	0.01	0.1	nA
			C, E	-5		5	
COM- Off-Leakage Current (Note 6)	ICOM-(OFF)	V+ = 15.5V; VCOM- = 14V, 1V; VNO- or VNC- = 1V, 14V	TA = +25°C	-0.1	0.01	0.1	nA
			C, E	-5		5	
COM- On-Leakage Current (Note 6)	ICOM-(ON)	V+ = 15.5V; VCOM- = 14V, 1V; VNO- or VNC- = 14V, 1V, or floating	TA = +25°C	-0.2	0.02	0.2	nA
			C, E	-10		10	
<b>DYNAMIC</b>							
Turn-On Time	tON	VNO- or VNC- = 10V, Figure 2	TA = +25°C	60	80	ns	
			C, E		90		
Turn-Off Time	tOFF	VNO- or VNC- = 10V, Figure 2	TA = +25°C	30	40	ns	
			C, E		50		
Break-Before-Make Time Delay (Note 3)	tD	MAX4593 only, RL = 300Ω, CL = 35pF	5	20		ns	
Charge Injection (Note 3)	Q	CL = 1nF, VGEN = 0, RGEN = 0Ω, Figure 4		2	5	pC	
<b>SUPPLY</b>							
Positive Supply Current	I+	V+ = 15V, VINL = 0 or V+, all channels on or off	-1	0.001	1	μA	
Negative Supply Current	I-	V+ = 15V, VINL = 0 or V+, all channels on or off	-1	0.001	1	μA	

**Note 2:** The algebraic convention, where the most negative value is a minimum and the most positive value a maximum, is used in this data sheet.

**Note 3:** Guaranteed by design.

**Note 4:** ΔRON = ΔRON max - ΔRON min.

**Note 5:** Flatness is defined as the difference between the maximum and minimum value of on-resistance as measured over the specified analog signal range.

**Note 6:** Leakage parameters are 100% tested at maximum rated hot temperature and guaranteed by correlation at +25°C.

**Note 7:** Off-isolation = 20log10 [VCOM / (VNC or VNO)], VCOM = output, VNC or VNO = input to off switch.

**Note 8:** Between any two switches.

# High-Speed, Single-Supply, Quad, SPST Analog Switches

## Typical Operating Characteristics

( $V_- = \text{GND} = 0$ ,  $I_{N-} = 0$  or  $V_+$ ,  $T_A = +25^\circ\text{C}$ , unless otherwise noted.)

MAX4591/MAX4592/MAX4593

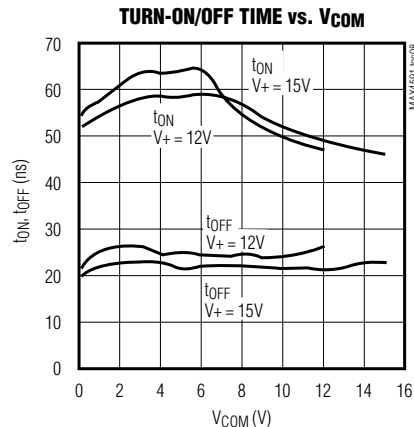
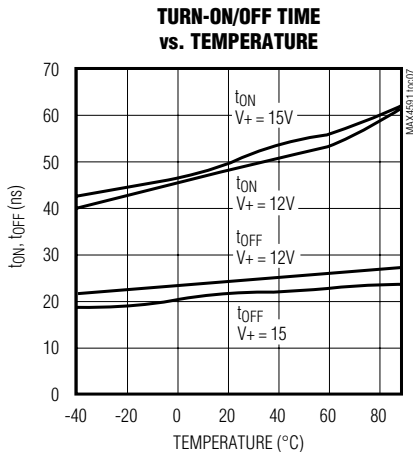
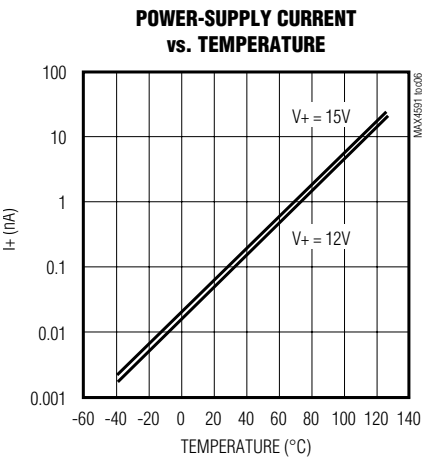
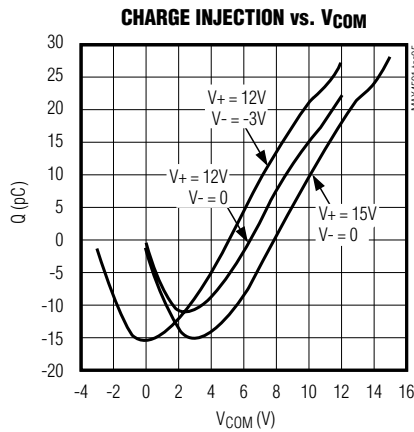
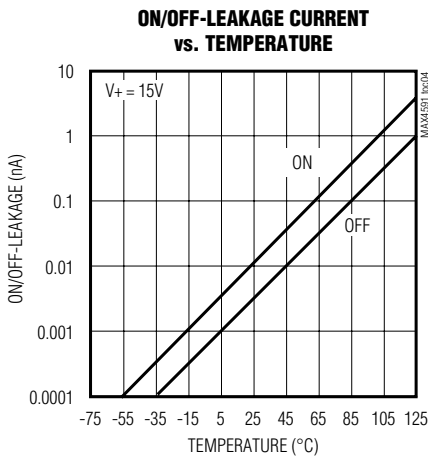
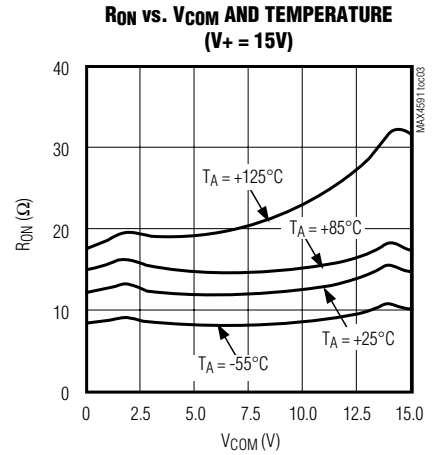
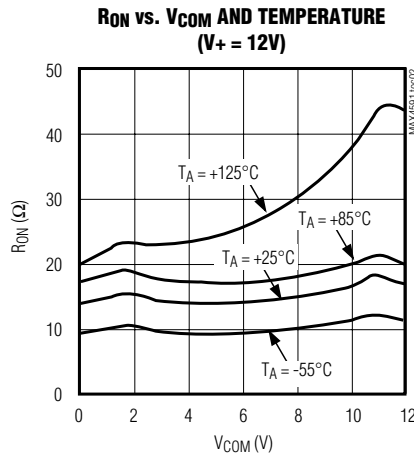
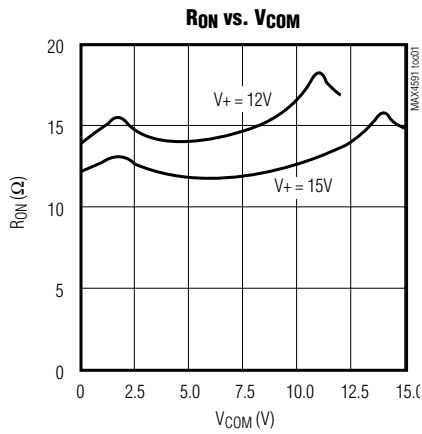

# High-Speed, Single-Supply, Quad, SPST Analog Switches

## Typical Operating Characteristics (continued)

(V- = GND = 0, IN- = 0 or V+, T<sub>A</sub> = +25°C, unless otherwise noted.)

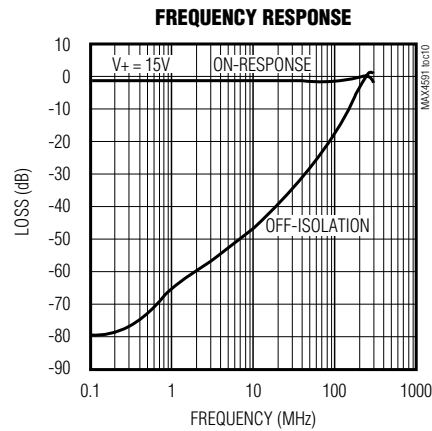
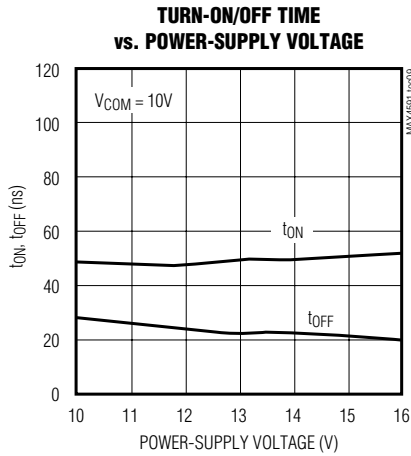

## Pin Description

PIN	NAME	FUNCTION
1, 16, 9, 8	IN1–IN4	Switch Input Terminals. Drive ≤ 0.8V for logic “0”; drive ≥ 5V for logic “1”.
2, 15, 10, 7	COM1–COM4	Analog Switch Common Terminal
3, 14, 11, 6	NO1–NO4 or NC1–NC4	Switch Inputs
4	V-	Negative Supply Voltage Input. Normally connected to ground.
5	GND	Ground
12	N.C.	No Connection. Not internally connected.
13	V+	Positive Supply Voltage Input. Connected to substrate.

## Applications Information

### Overvoltage Protection

Proper power-supply sequencing is recommended for all CMOS devices. Do not exceed the absolute maximum ratings because stresses beyond the listed ratings may cause permanent damage to the devices. Always sequence V+ on first, followed by the logic inputs. If power-supply sequencing is not possible, add a small signal diode in series with V+ for overvoltage protection (Figure 1). Adding a diode reduces the analog signal range to 1V below V+, but low switch resistance and low leakage characteristics are unaffected. Device operation is unchanged, and the difference between V+ and V- should not exceed 17V.

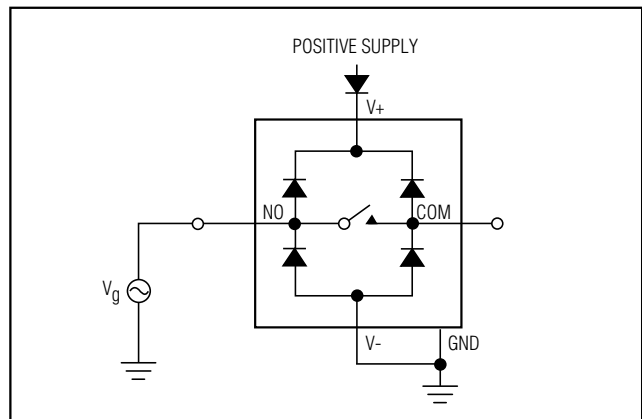

Figure 1. Overvoltage Protection Using Two External Blocking Diodes

# High-Speed, Single-Supply, Quad, SPST Analog Switches

## Test Circuits/Timing Diagrams

MAX4591/MAX4592/MAX4593

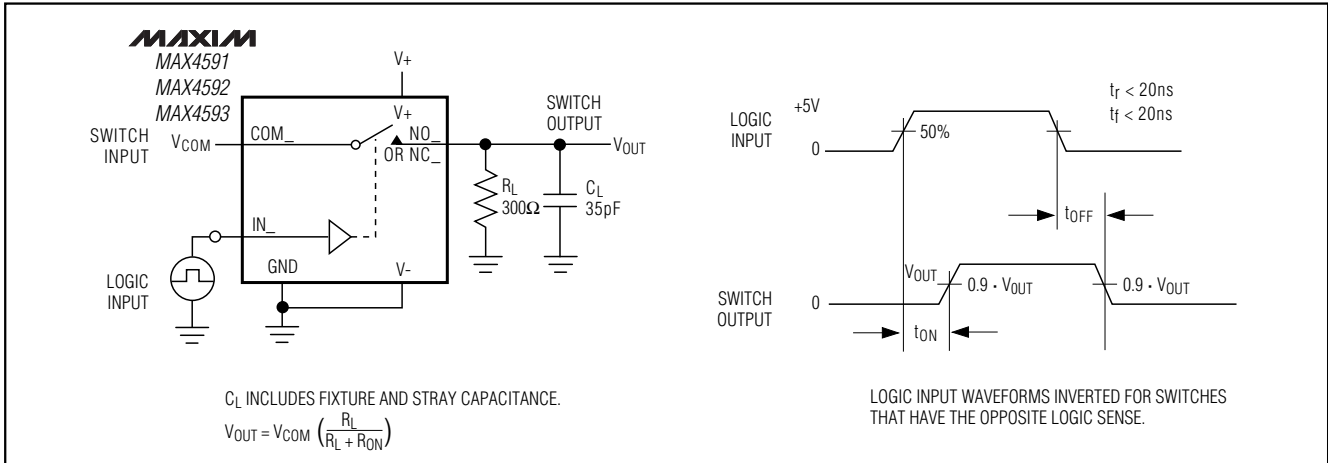

Figure 2. Switching Time

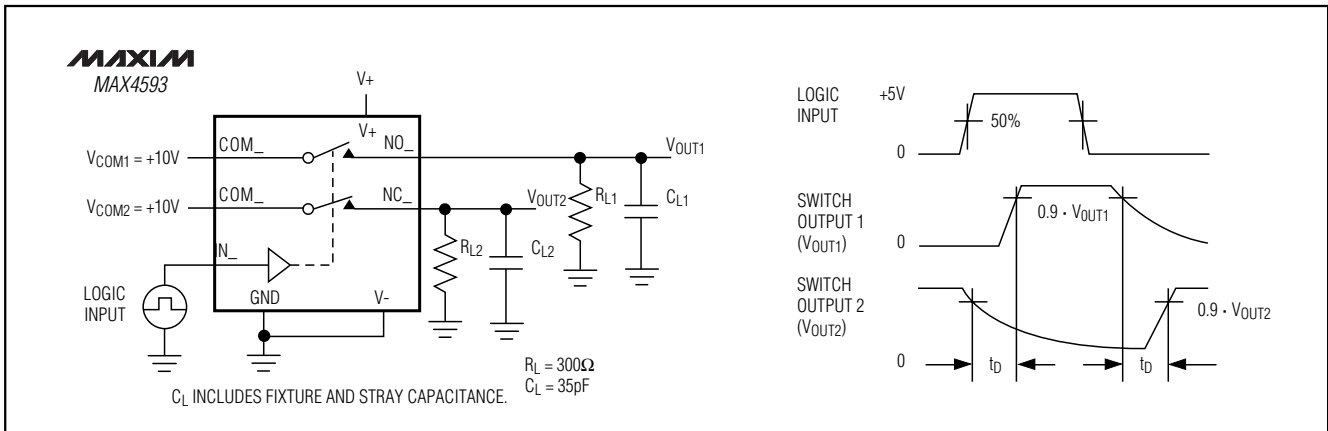

Figure 3. Break-Before-Make Interval (MAX4593 Only)

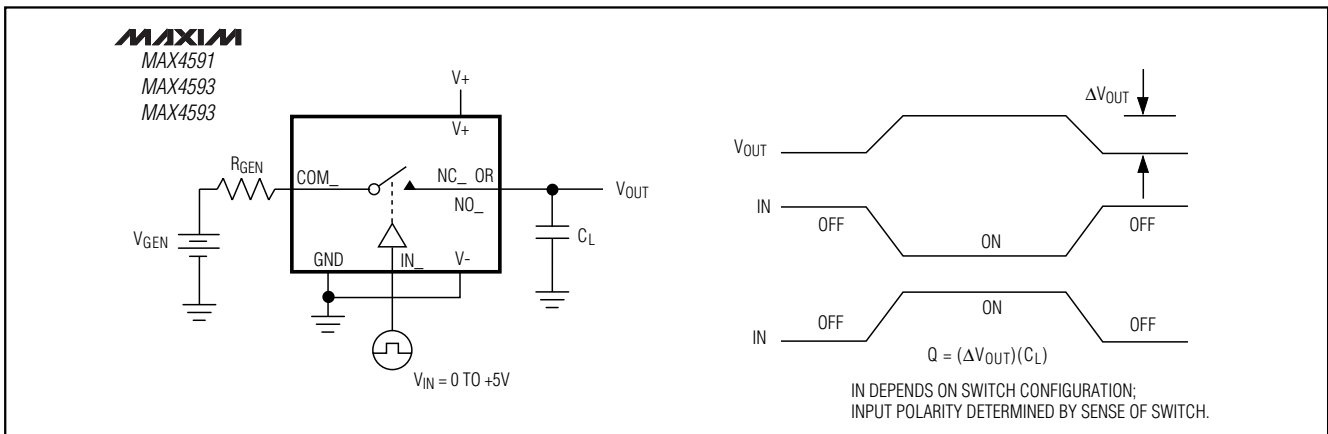

Figure 4. Charge Injection

# High-Speed, Single-Supply, Quad, SPST Analog Switches

## Test Circuits/Timing Diagrams (continued)

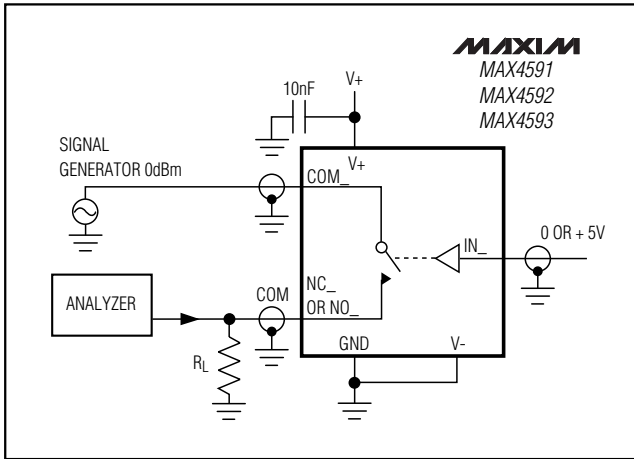

Figure 5. Off-Isolation

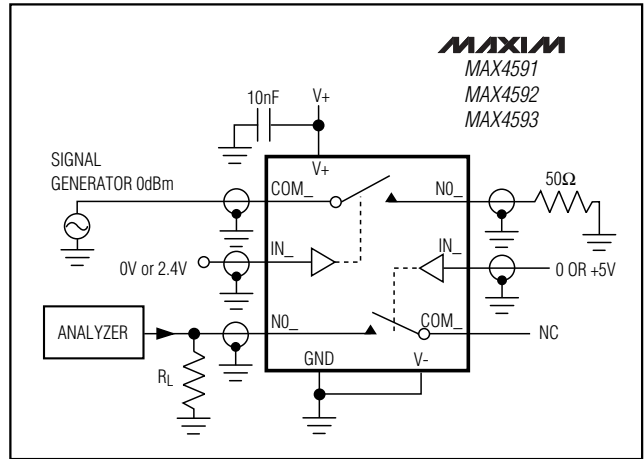

Figure 6. Crosstalk

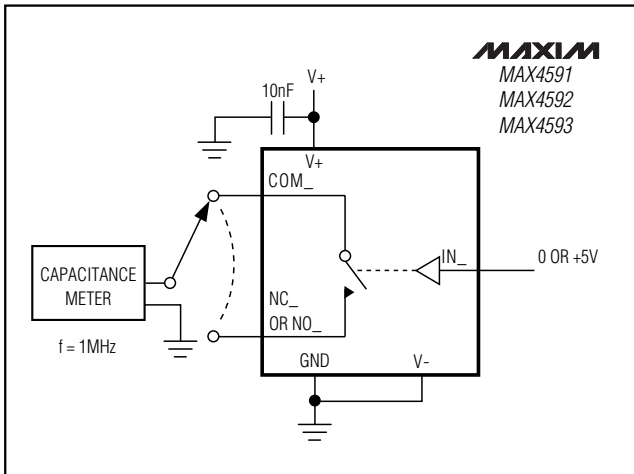

Figure 7. Channel Off-Capacitance

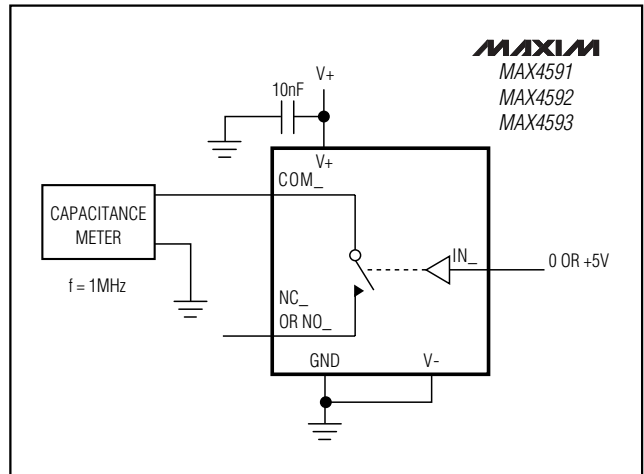

Figure 8. Channel On-Capacitance

# High-Speed, Single-Supply, Quad, SPST Analog Switches

## Ordering Information (continued)

PART	TEMP. RANGE	PIN-PACKAGE
MAX4592CUE	0°C to +70°C	16 TSSOP
MAX4592CSE	0°C to +70°C	16 Narrow SO
MAX4592CPE	0°C to +70°C	16 Plastic DIP
MAX4592EUE	-40°C to +85°C	16 TSSOP
MAX4592ESE	-40°C to +85°C	16 Narrow SO
MAX4592EPE	-40°C to +85°C	16 Plastic DIP
MAX4593CUE	0°C to +70°C	16 TSSOP
MAX4593CSE	0°C to +70°C	16 Narrow SO
MAX4593CPE	0°C to +70°C	16 Plastic DIP
MAX4593EUE	-40°C to +85°C	16 TSSOP
MAX4593ESE	-40°C to +85°C	16 Narrow SO
MAX4593EPE	-40°C to +85°C	16 Plastic DIP

## Chip Information

TRANSISTOR COUNT: 76

MAX4591/MAX4592/MAX4593

## Package Information

DIMENSION				MILLIMETERS				INCHES			
A	1.75	0.069	1.75	0.069	0.069	0.069	0.069	0.069	0.069	0.069	0.069
B	1.75	0.069	1.75	0.069	0.069	0.069	0.069	0.069	0.069	0.069	0.069
C	1.75	0.069	1.75	0.069	0.069	0.069	0.069	0.069	0.069	0.069	0.069
D	1.75	0.069	1.75	0.069	0.069	0.069	0.069	0.069	0.069	0.069	0.069
E	1.75	0.069	1.75	0.069	0.069	0.069	0.069	0.069	0.069	0.069	0.069
F	1.75	0.069	1.75	0.069	0.069	0.069	0.069	0.069	0.069	0.069	0.069
G	1.75	0.069	1.75	0.069	0.069	0.069	0.069	0.069	0.069	0.069	0.069
H	1.75	0.069	1.75	0.069	0.069	0.069	0.069	0.069	0.069	0.069	0.069
I	1.75	0.069	1.75	0.069	0.069	0.069	0.069	0.069	0.069	0.069	0.069
J	1.75	0.069	1.75	0.069	0.069	0.069	0.069	0.069	0.069	0.069	0.069
K	1.75	0.069	1.75	0.069	0.069	0.069	0.069	0.069	0.069	0.069	0.069
L	1.75	0.069	1.75	0.069	0.069	0.069	0.069	0.069	0.069	0.069	0.069
M	1.75	0.069	1.75	0.069	0.069	0.069	0.069	0.069	0.069	0.069	0.069
N	1.75	0.069	1.75	0.069	0.069	0.069	0.069	0.069	0.069	0.069	0.069
O	1.75	0.069	1.75	0.069	0.069	0.069	0.069	0.069	0.069	0.069	0.069
P	1.75	0.069	1.75	0.069	0.069	0.069	0.069	0.069	0.069	0.069	0.069
Q	1.75	0.069	1.75	0.069	0.069	0.069	0.069	0.069	0.069	0.069	0.069
R	1.75	0.069	1.75	0.069	0.069	0.069	0.069	0.069	0.069	0.069	0.069
S	1.75	0.069	1.75	0.069	0.069	0.069	0.069	0.069	0.069	0.069	0.069
T	1.75	0.069	1.75	0.069	0.069	0.069	0.069	0.069	0.069	0.069	0.069
U	1.75	0.069	1.75	0.069	0.069	0.069	0.069	0.069	0.069	0.069	0.069
V	1.75	0.069	1.75	0.069	0.069	0.069	0.069	0.069	0.069	0.069	0.069
W	1.75	0.069	1.75	0.069	0.069	0.069	0.069	0.069	0.069	0.069	0.069
X	1.75	0.069	1.75	0.069	0.069	0.069	0.069	0.069	0.069	0.069	0.069
Y	1.75	0.069	1.75	0.069	0.069	0.069	0.069	0.069	0.069	0.069	0.069
Z	1.75	0.069	1.75	0.069	0.069	0.069	0.069	0.069	0.069	0.069	0.069

**NOTES:**

- DIMENSIONS B AND C DO NOT INCLUDE FLASH.
- MOLD FLASH OR PROTRUSIONS NOT TO EXCEED 25 μm PER SIDE.
- CONTROLLING DIMENSION MILLIMETER.
- LEADS JEDEC OUTLINE MO-153 VARIATIONS FOR AC, AD, AE, AF.
- DIMENSIONS M AND Y APPLY TO EXPOSED PAD DIP VERSIONS ONLY.
- EXPOSED PAD FLUSH WITH BOTTOM OF PACKAGE WITHIN 0.1mm.

**MAXIM**

PACKAGE OUTLINE, TSSOP, 16-PIN JEDEC MO-153, 16-PIN PITCH

REVISION: 01

DATE: 01-06-06

BY: G

CHK: X

# High-Speed, Single-Supply, Quad, SPST Analog Switches

## Package Information (continued)

	INCHES		MILLIMETERS	
	MIN	MAX	MIN	MAX
A	0.053	0.069	1.35	1.75
A1	0.004	0.010	0.10	0.25
B	0.014	0.019	0.35	0.49
C	0.007	0.010	0.19	0.25
e	0.050		1.27	
E	0.150	0.157	3.80	4.00
H	0.228	0.244	5.80	6.20
h	0.010	0.020	0.25	0.50
L	0.016	0.050	0.40	1.27

	INCHES		MILLIMETERS		N	MS012
	MIN	MAX	MIN	MAX		
D	0.189	0.197	4.80	5.00	8	A
D	0.337	0.344	8.55	8.75	14	B
D	0.386	0.394	9.80	10.00	16	C

NOTES:  
 1. D&E DO NOT INCLUDE MOLD FLASH  
 2. MOLD FLASH OR PROTRUSIONS NOT TO EXCEED .15mm (.006")  
 3. LEADS TO BE COPLANAR WITHIN .102mm (.004")  
 4. CONTROLLING DIMENSION: MILLIMETER  
 5. MEETS JEDEC MS012-XX AS SHOWN IN ABOVE TABLE  
 6. N = NUMBER OF PINS

**MAXIM** PACKAGE FAMILY OUTLINE: SOIC .150° 1/1 21-0041 A  
MAXIM IS A REGISTERED TRADEMARK OF MAXIM INTEGRATED PRODUCTS. © 2001 MAXIM INTEGRATED PRODUCTS. ALL RIGHTS RESERVED.



# **High-Speed, Single-Supply, Quad, SPST Analog Switches**

## **NOTES**

*Maxim cannot assume responsibility for use of any circuitry other than circuitry entirely embodied in a Maxim product. No circuit patent licenses are implied. Maxim reserves the right to change the circuitry and specifications without notice at any time.*

**12** \_\_\_\_\_ **Maxim Integrated Products, 120 San Gabriel Drive, Sunnyvale, CA 94086 408-737-7600**

## Looking for pricing, stock, or lifecycle information?

Click below to explore more details on WIN SOURCE:

 [View MAX4591CSE on WIN SOURCE](#)

 [Maxim Integrated](#) Information

## Optimize Your Supply Chain with WIN SOURCE Solutions

-  Global Sourcing Solution
-  Obsolete Management
-  Cost Control Management
-  Shortage Management
-  Alternative Solution
-  Excess Inventory Management