



**THE DATASHEET OF
AP1603WL-7**



Description

The AP1603 is a high efficiency step-up DC-DC converter for applications using as few as a single NiMH or Li-Ion battery cells. Only four external components are required to deliver a fixed output voltage of 3.3V. The AP1603 starts up from less than 0.9V input with 1mA load. Pulse Frequency Modulation scheme brings optimized performance for applications with light output loading and low input voltages. The output ripple and noise are lower compared with the circuits operating in PSM mode.

The PFM control circuit operating in 150kHz (max.) switching rate results in smaller passive components. The space saving SOT26 packages make the AP1603 an ideal choice of DC-DC converter for space conscious applications, like pagers, electronic cameras, and wireless microphones.

Features

- A Guaranteed Start-Up from less than 0.9 V
- High Efficiency
- Low Quiescent Current
- Less Number of External Components needed
- Low Ripple and Low Noise
- Space Saving Lead Free Package: SOT26
- Available in Green molding
- **Totally Lead-Free & Fully RoHS Compliant (Notes 1 & 2)**
- **Halogen and Antimony Free. "Green" Device (Note 3)**

Notes: 1. No purposely added lead. Fully EU Directive 2002/95/EC (RoHS) & 2011/65/EU (RoHS 2) compliant.
2. See http://www.diodes.com/quality/lead_free.html for more information about Diodes Incorporated's definitions of Halogen- and Antimony-free, "Green" and Lead-free.
3. Halogen- and Antimony-free "Green" products are defined as those which contain <900ppm bromine, <900ppm chlorine (<1500ppm total Br + Cl) and <1000ppm antimony compounds.

Pin Assignments

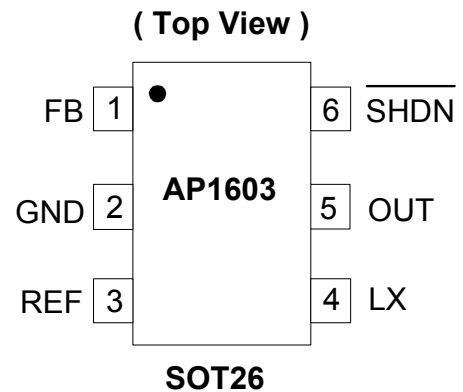

Applications

- Pagers
- Cameras
- Wireless Microphones
- Pocket Organizers
- Battery Backup Suppliers
- Portable Instruments

Typical Applications Circuit

(1) $V_{OUT} = 5V$

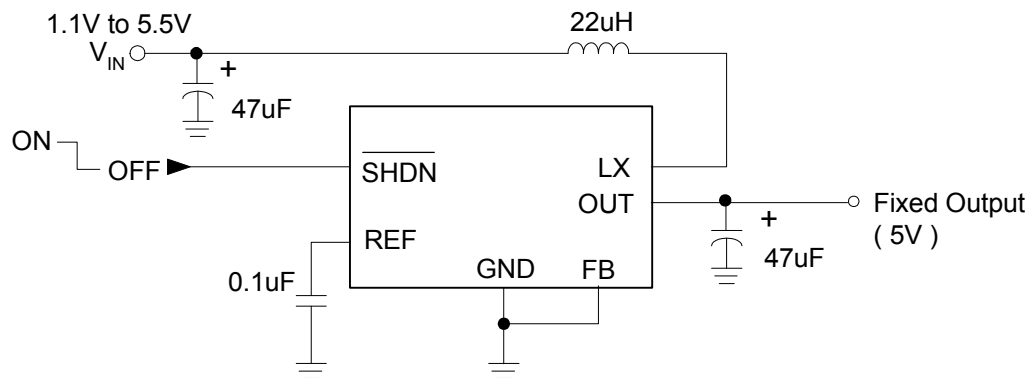

Typical Applications Circuit (cont.)

(2) $V_{OUT} = 3.3V$

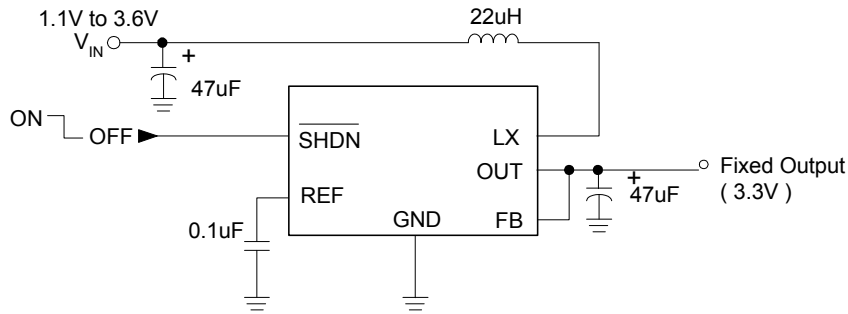

(3) $V_{OUT} = ADJ$

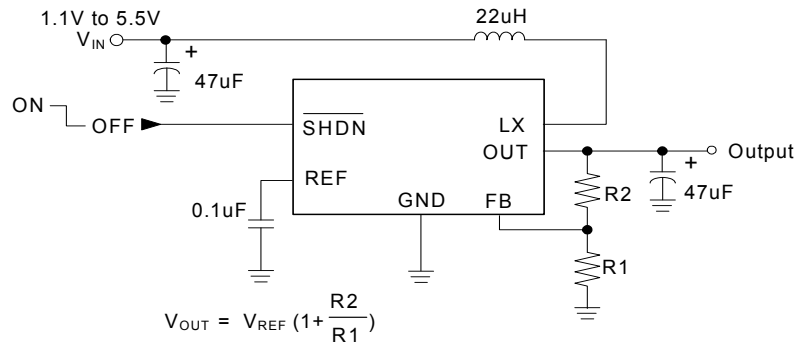

Pin Descriptions

Pin Name	Function
FB	Feedback.
GND	Ground.
REF	1.2V Reference Voltage. Bypass with a 0.1µF capacitor.
LX	N-Channel and P-Channel Power MOSFET Drain.
OUT	Power Output. OUT provides bootstrap power to the IC.
SHDN	Shutdown Input. Drive high (>80% of V_{OUT}) for operating mode. Drive low (<20% of V_{OUT}) for shutdown mode. Connect to OUT for normal operation.

Functional Block Diagram

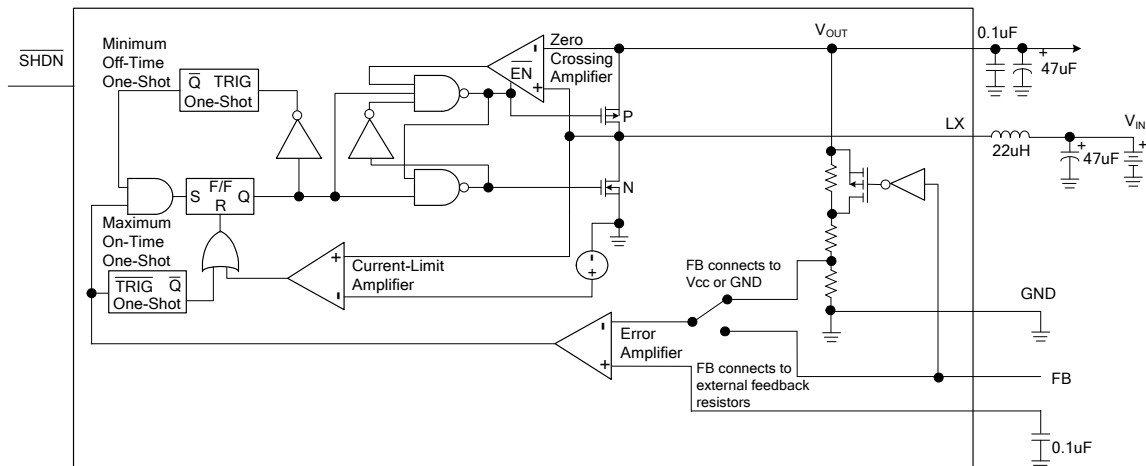

Absolute Maximum Ratings (@ $T_A = +25^\circ\text{C}$, unless otherwise specified.)

Symbol	Parameter	Rating	Unit
V_{CC}	Supply Voltage (OUT to GND)	-0.3 to 5.5	V
V_{REF}	REF to GND	-0.3 to $V_{OUT} + 0.3$	V
V_{SW}	Switch Voltage (LX to GND)	-0.3 to $V_{OUT} + 0.3$	V
I_{OUT}	Output Current (OUT)	-0.8 to 0.2	A
I_{SW}	Switch Current (LX)	-0.8 to 0.2	A
T_{ST}	Storage Temperature Range	-65 to +150	$^\circ\text{C}$
T_{OP}	Operation Temperature Range	-40 to +85	$^\circ\text{C}$

Electrical Characteristics ($V_{IN} = 2\text{V}$, $F_B = V_{OUT}$, $R_L = \infty$, $T_A = 0^\circ\text{C}$ to $+85^\circ\text{C}$, unless otherwise specified. Typical Values @ $T_A = +25^\circ\text{C}$)

Symbol	Parameter	Conditions	Min	Typ	Max	Unit
	Minimum Input Voltage		—	0.9	—	V
V_{IN}	Operating Voltage	$T_A = +25^\circ\text{C}$	1.1	—	5.5	V
	Start-Up Voltage	$T_A = +25^\circ\text{C}$, $R_L = 3\text{k}\Omega$ (Note 4)	—	0.9	1.1	V
	Start-Up Voltage Tempco		—	-4	—	$\text{mV}/^\circ\text{C}$
	Output Voltage Range		2	—	5.5	V
I_{OUT}	Steady-State Output Current (Note 5)	$F_B = V_{OUT} = 3.3\text{V}$	100	150	—	mA
		$V_{IN} = 2.4\text{V}$, $F_B = \text{GND}$, $V_{OUT} = 5\text{V}$	—	80	—	
V_{REF}	Reference Voltage	$I_{REF} = 0$	1.196	1.22	1.244	V
V_{OUT}	Output Voltage	$F_B = V_{OUT}$	3.17	3.3	3.43	V
		$F_B = \text{GND}$	4.8	5	5.2	
TEMPCO	Reference Voltage Tempco		—	0.05	—	$\text{mV}/^\circ\text{C}$
V_{REF_LOAD}	Reference Voltage Load Regulation	$I_{REF} = 0$ to $20\mu\text{A}$	—	15	80	mV
V_{REF_LINE}	Reference Voltage Line Regulation	$V_{IN} = 1.1\text{V}$ to 3.6V	—	0.08	1.5	mV/V
$R_{DS(ON)}$	Internal NFET, PFET On-Resistance	$I_{LX} = 100\text{mA}$	—	0.6	1.0	Ω
I_{LIM}	LX Switch Current Limit (NFET)		0.3	0.35	0.4	A
I_{LEAK}	LX Leakage Current	$V_{LX} = 0, 5.5\text{V}$; $V_{OUT} = 5.5\text{V}$	—	0.05	1	μA
	Operating Current into OUT	$V_{OUT} = 3.3\text{V}$	—	16	35	μA
	Shutdown Current into OUT	$\overline{\text{SHDN}} = \text{GND}$	—	0.1	1	μA
	Efficiency	$V_{OUT} = 3.3\text{V}$, $I_{LOAD} = 100\text{mA}$	—	90	—	%
t_{ON}	LX Switch On-Time		3	4	7	μs
t_{OFF}	LX Switch Off-Time		1.0	1.2	1.4	μs
$I_{\overline{\text{SHDN}}}$	$\overline{\text{SHDN}}$ Input Current	$V_{\overline{\text{SHDN}}} = 0$ or V_{OUT}	—	0.07	50	nA
V_{IL}	$\overline{\text{SHDN}}$ Input Voltage	Based on V_{OUT} Voltage	—	—	0.2	V_{OUT}
V_{IH}			0.8	—	—	

Notes: 4. Start-up voltage operation is guaranteed with the addition of a Schottky 1N5819 external diode between the input and output.
5. Steady-state output current indicates that the device maintains output voltage regulation under load.

Typical Performance Characteristics

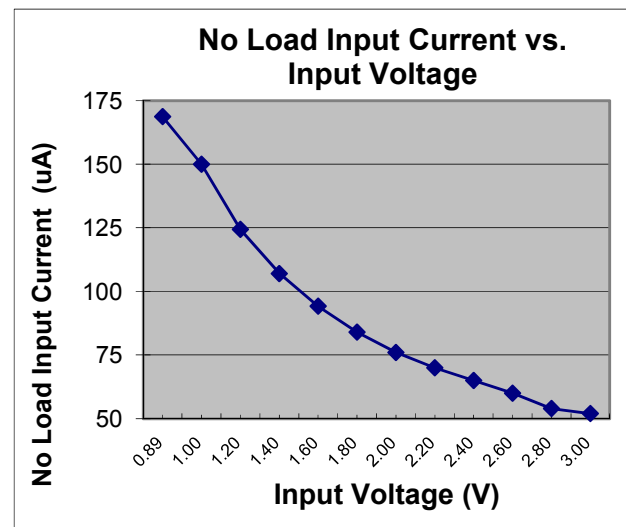
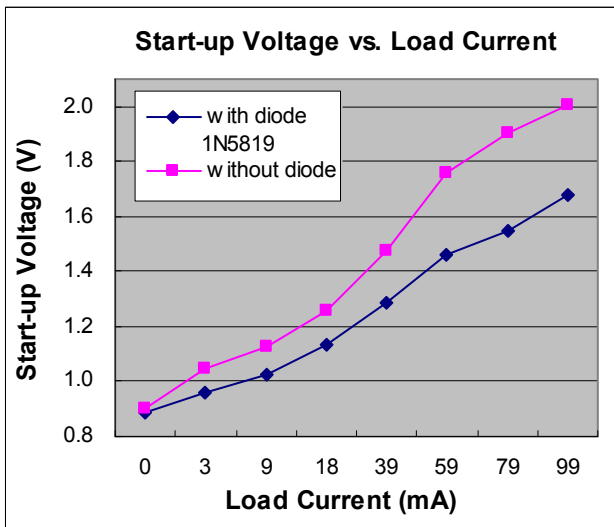
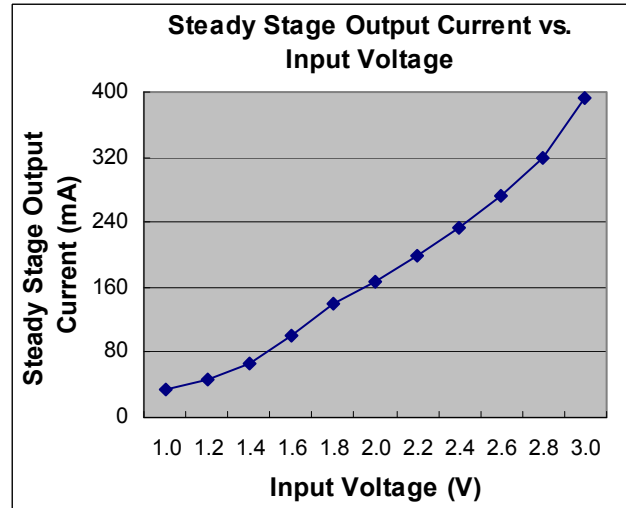
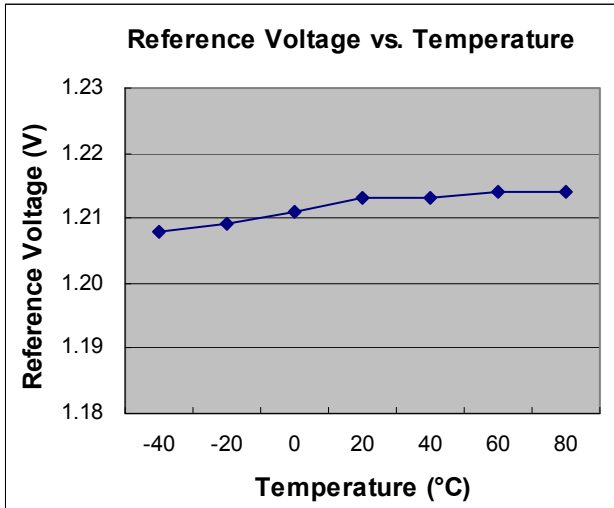

Typical Performance Characteristics (cont.)

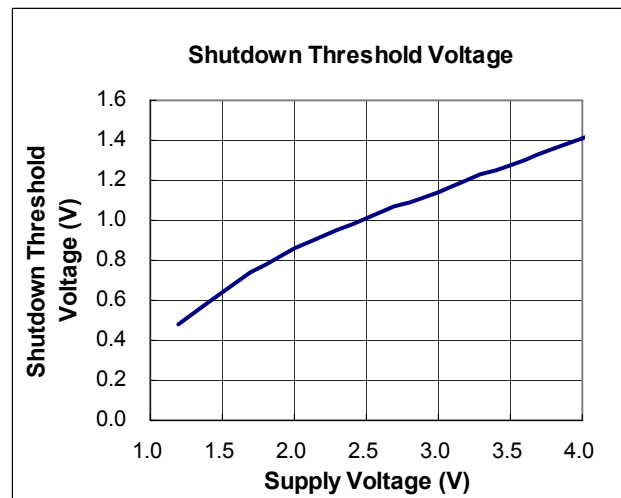
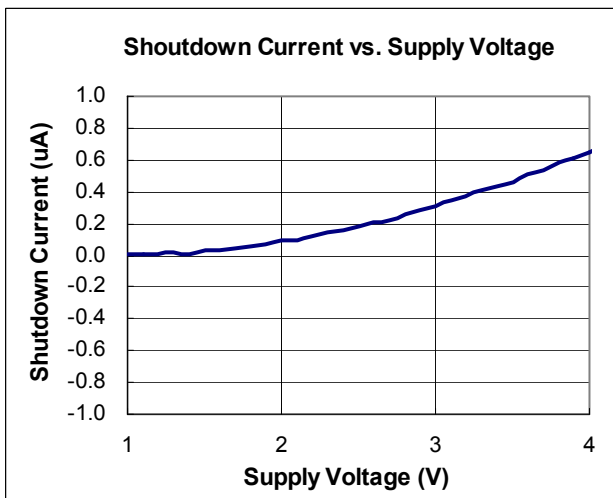
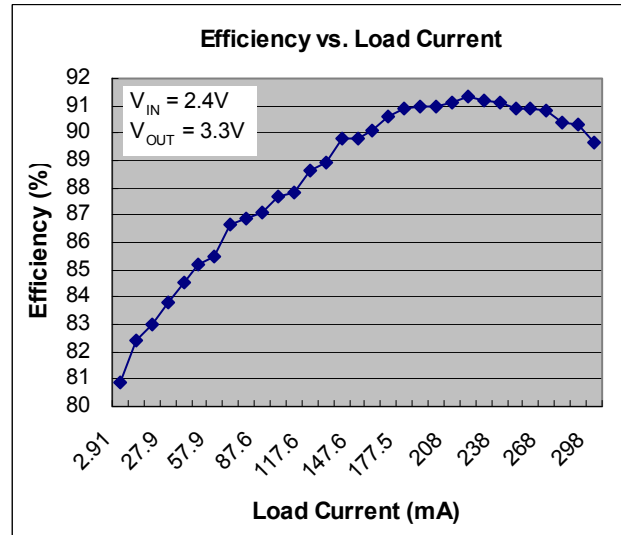
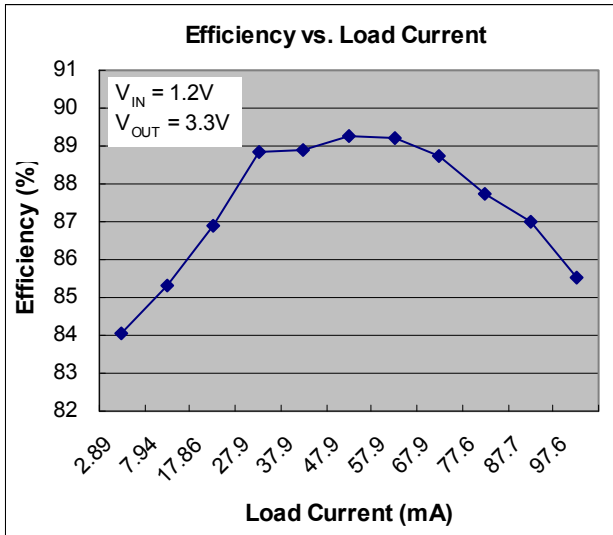

Function Description

General Description

AP1603 PFM (Pulse Frequency Modulation) converter IC series combine a switch mode converter, power MOSFET, and precision voltage reference in a single monolithic device. They offer both extreme low quiescent current, high efficiency, and very low gate threshold voltage to ensure start-up with low battery voltage (0.9V typ.). Designed to maximize battery life in portable products, and minimize switching losses by only switching as needed to service the load. PFM converters transfer a discrete amount of energy per cycle and regulate the output voltage by modulating switching frequency with the constant turn-on time. Switching frequency depends on the load, input voltage, and inductor value, and it can range up to 150kHz. The SW on resistance is typically 1 to 1.5 W to minimize switch losses. When the output voltage drops, the error comparator enables 150kHz oscillator that turns on the MOSFET around 7.5us and 2.5ms off time. Turning on the MOSFET allows inductor current to ramp up, storing energy in a magnetic field and when MOSFET turns off that force inductor current through the diode to the output capacitor and load. As the stored energy is depleted, the current ramp down until the diode turns off. At this point, inductor may ring due to residual energy and stray capacitance. The output capacitor stores charge when current flow through the diode is high, and release it when the current flow is low, thereby maintaining a steady voltage across the load. As the load increases, the output capacitor discharges faster and the error comparator initiates cycles sooner, increasing the switching frequency. The maximum duty cycle ensures adequate time for energy transfer to output during the second half of each cycle. Depending on the circuit, PFM converter can operate in either discontinuous mode or continuous conduction mode. Continuous conduction mode means that the inductor current does not ramp to zero during each cycle.

Inductor Selection

To operate as an efficient energy transfer element, the inductor must fulfill three requirements. First, the inductance must be low enough for the inductor to store adequate energy under the worst-case condition of minimum input voltage and switch ON time. Second, the inductance must also be high enough so the maximum current rating of AP1603 and inductor are not exceeded at the other worst-case condition of maximum input voltage and ON time. Lastly, the inductor must have sufficiently low DC resistance so excessive power is not lost as heat in the windings. But unfortunately this is inversely related to physical size. Minimum and Maximum input voltage, output voltage and output current must be established before an inductor can be selected.

Capacitor Selection

A poor choice for an output capacitor can result in poor efficiency and high output ripple. Ordinary aluminum electrolytic capacitors, while inexpensive, may have unacceptably poor ESR and ESL. There is a low ESR aluminum capacitor for switch mode DC-DC converters which work much better than the general purpose unit. Tantalum capacitors provide still better performance at more expense. OS-CON capacitors have extremely low ESR in a small size. If capacitance is reduced, the output ripple will increase. Most of the input supply is supplied by the input bypass capacitor. The capacitor voltage rating should be at least 1.25 times greater than a maximum input voltage.

Ordering Information

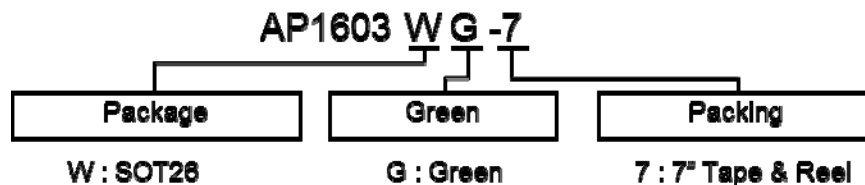

Part Number	Package Code	Packaging	7" Tape and Reel	
			Quantity	Part Number Suffix
AP1603WG-7	W	SOT26	3000/Tape & Reel	-7

Marking Information

(1) SOT26

(Top View)

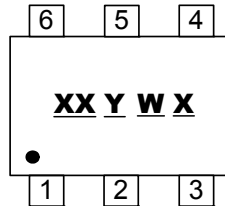

XX : Identification code
 Y : Year 0~9
 W : Week : A#Z : 1~26 week
 a~z : 27~52 week; z represents
 52 and 53 week
 X : A~Z : Green

Part Number	Package	Identification Code
AP1603W	SOT26	EY

Package Outline Dimensions (All dimensions in mm.)

Please see AP02002 at <http://www.diodes.com/datasheets/ap02002.pdf> for latest version.

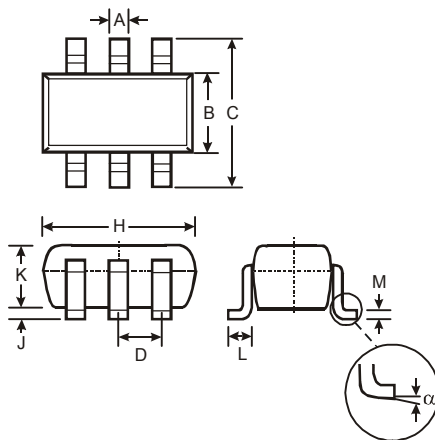

SOT26			
Dim	Min	Max	Typ
A	0.35	0.50	0.38
B	1.50	1.70	1.60
C	2.70	3.00	2.80
D	—	—	0.95
H	2.90	3.10	3.00
J	0.013	0.10	0.05
K	1.00	1.30	1.10
L	0.35	0.55	0.40
M	0.10	0.20	0.15
α	0°	8°	—
All Dimensions in mm			

Suggested Pad Layout

Please see AP02001 at <http://www.diodes.com/datasheets/ap02001.pdf> for the latest version.

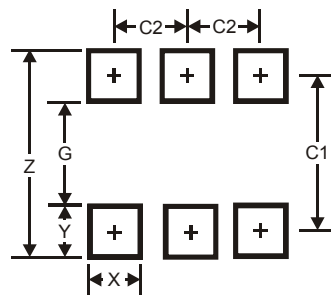

Dimensions	Value (in mm)
Z	3.20
G	1.60
X	0.55
Y	0.80
C1	2.40
C2	0.95

IMPORTANT NOTICE

DIODES INCORPORATED MAKES NO WARRANTY OF ANY KIND, EXPRESS OR IMPLIED, WITH REGARDS TO THIS DOCUMENT, INCLUDING, BUT NOT LIMITED TO, THE IMPLIED WARRANTIES OF MERCHANTABILITY AND FITNESS FOR A PARTICULAR PURPOSE (AND THEIR EQUIVALENTS UNDER THE LAWS OF ANY JURISDICTION).

Diodes Incorporated and its subsidiaries reserve the right to make modifications, enhancements, improvements, corrections or other changes without further notice to this document and any product described herein. Diodes Incorporated does not assume any liability arising out of the application or use of this document or any product described herein; neither does Diodes Incorporated convey any license under its patent or trademark rights, nor the rights of others. Any Customer or user of this document or products described herein in such applications shall assume all risks of such use and will agree to hold Diodes Incorporated and all the companies whose products are represented on Diodes Incorporated website, harmless against all damages.

Diodes Incorporated does not warrant or accept any liability whatsoever in respect of any products purchased through unauthorized sales channel. Should Customers purchase or use Diodes Incorporated products for any unintended or unauthorized application, Customers shall indemnify and hold Diodes Incorporated and its representatives harmless against all claims, damages, expenses, and attorney fees arising out of, directly or indirectly, any claim of personal injury or death associated with such unintended or unauthorized application.

Products described herein may be covered by one or more United States, international or foreign patents pending. Product names and markings noted herein may also be covered by one or more United States, international or foreign trademarks.

This document is written in English but may be translated into multiple languages for reference. Only the English version of this document is the final and determinative format released by Diodes Incorporated.

LIFE SUPPORT

Diodes Incorporated products are specifically not authorized for use as critical components in life support devices or systems without the express written approval of the Chief Executive Officer of Diodes Incorporated. As used herein:

A. Life support devices or systems are devices or systems which:

1. are intended to implant into the body, or
2. support or sustain life and whose failure to perform when properly used in accordance with instructions for use provided in the labeling can be reasonably expected to result in significant injury to the user.

B. A critical component is any component in a life support device or system whose failure to perform can be reasonably expected to cause the failure of the life support device or to affect its safety or effectiveness.

Customers represent that they have all necessary expertise in the safety and regulatory ramifications of their life support devices or systems, and acknowledge and agree that they are solely responsible for all legal, regulatory and safety-related requirements concerning their products and any use of Diodes Incorporated products in such safety-critical, life support devices or systems, notwithstanding any devices- or systems-related information or support that may be provided by Diodes Incorporated. Further, Customers must fully indemnify Diodes Incorporated and its representatives against any damages arising out of the use of Diodes Incorporated products in such safety-critical, life support devices or systems.

Copyright © 2014, Diodes Incorporated

www.diodes.com

Looking for pricing, stock, or lifecycle information?

Click below to explore more details on WIN SOURCE:

- ⊖ [View AP1603WL-7 on WIN SOURCE](#)
- ⊖ [Diodes Incorporated Information](#)

Optimize Your Supply Chain with WIN SOURCE Solutions

- ✓ Global Sourcing Solution
- ✓ Obsolete Management
- ✓ Cost Control Management
- ✓ Shortage Management
- ✓ Alternative Solution
- ✓ Excess Inventory Management