



**THE DATASHEET OF**  
**AP1605SG-13**



## Description

AP1605 consists of CMOS step-down switching regulator with PWM/PFM dual mode control. These devices include a reference voltage source, oscillation circuit, error amplifier, internal PMOS and etc.

AP1605 provides low-ripple power, high efficiency, and excellent transient characteristics. The PWM/PFM control circuit is able to vary the duty ratio linearly 0%~0.25% (PFM) and 25%~100% (PWM).

With the addition of an internal P-channel Power MOS, a coil, capacitors, and a diode connected externally, these ICs can function as step-down switching regulators. They serve as ideal power supply units for portable devices when coupled with the SO-8 mini-package, providing such outstanding features as low current consumption. Since this converter can accommodate an input voltage of up to 7V, it is also ideal when operating via an AC adapter.

## Features

- Low Current Consumption:
  - In Operation: 100µA max.
  - Power Off: 2µA max.
- Input Voltage: 2.5V to 7V  
Adjustable Version ( $\pm 2.5\%$ )
- PWM/PFM Dual Mode
- Oscillation Frequency: 300kHz (Typ.)
- With a Power-off Function
- Built-in Internal SW P-channel MOS
- **Totally Lead-Free & Fully RoHS Compliant (Notes 1 & 2)**
- **Halogen and Antimony Free. "Green" Device (Note 3)**

- Notes:
1. No purposely added lead. Fully EU Directive 2002/95/EC (RoHS) & 2011/65/EU (RoHS 2) compliant.
  2. See [http://www.diodes.com/quality/lead\\_free.html](http://www.diodes.com/quality/lead_free.html) for more information about Diodes Incorporated's definitions of Halogen- and Antimony-free, "Green" and Lead-free.
  3. Halogen- and Antimony-free "Green" products are defined as those which contain <900ppm bromine, <900ppm chlorine (<1500ppm total Br + Cl) and <1000ppm antimony compounds.

## Pin Assignments

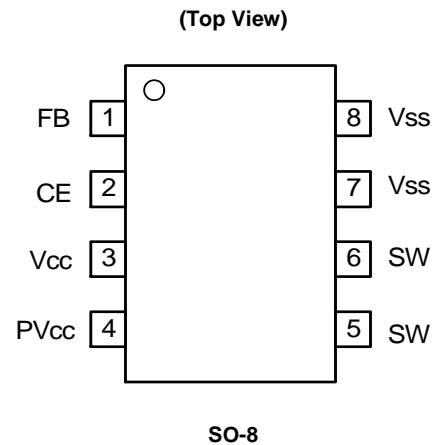

## Applications

- On-board Power Supply of Battery Devices for Portable Telephones, Electronic Notebooks, PDA, and Other Hand-held Sets
- Power Supplies for Audio Equipment, Including Portable CD Players and Headphone Stereo Equipment
- Fixed Voltage Power Supply for Cameras, Video Equipment and Communications Equipment
- Power Supplies for Microcomputers
- Conversion from Four Ni-H or Ni-Cd Cells or Two Lithium-ion Cells to 3.3V/3V
- Conversion of AC Adapter Input to 5V/3V

**Typical Applications Circuit**

(1) Normal Application

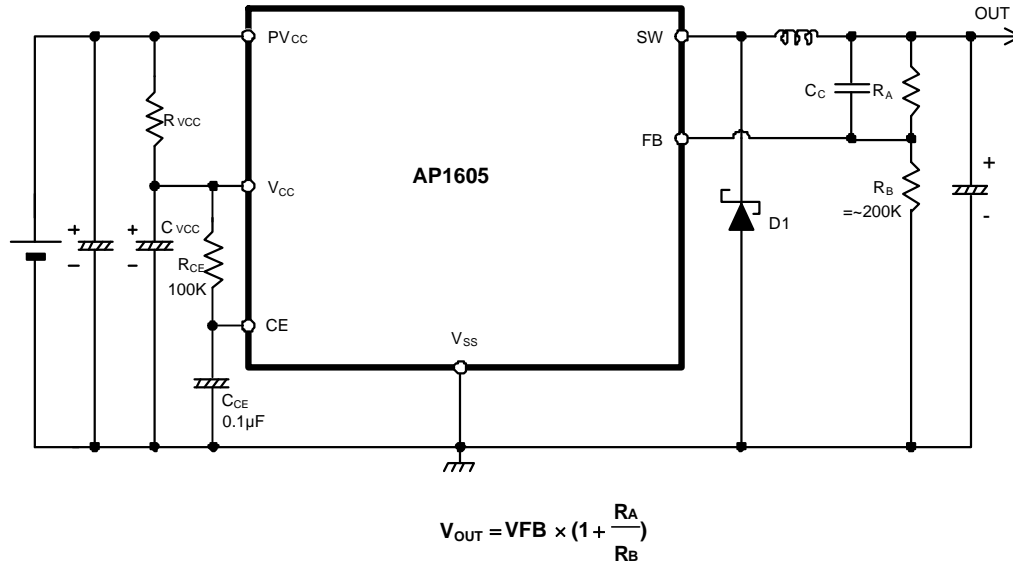

(2) Application with Short Circuit Protection

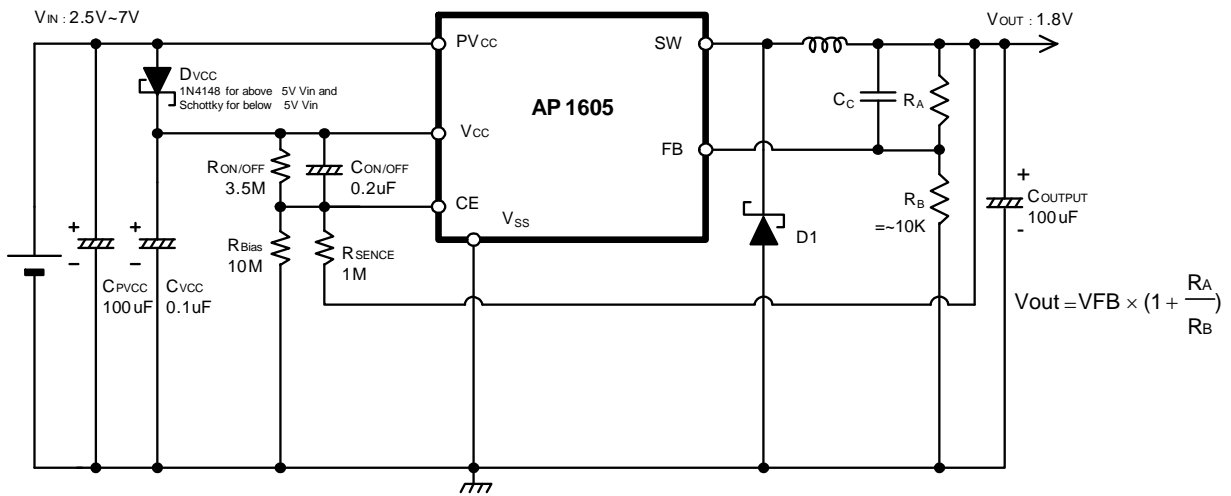

## Pin Descriptions

Pin Number	Pin Name	Description
1	FB	Feedback pin
2	CE	Chip Enable: H: Enable L: Disable
3	V <sub>CC</sub>	IC signal power supply pin, add a 10Ω resistor to PV <sub>CC</sub> and a 0.1μF capacitor to GND.
4	PV <sub>CC</sub>	IC power supply pin
5, 6	SW	Switch Pin. Connect external inductor/diode here. Minimize trace area at this pin to reduce EMI.
7, 8	V <sub>SS</sub>	GND Pin

## Functional Block Diagram

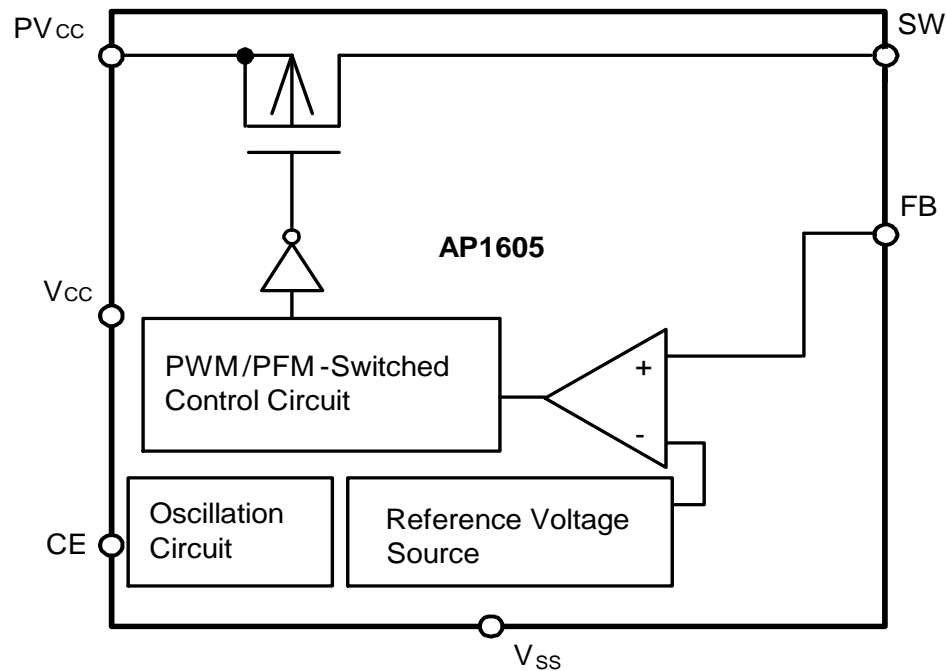

## Absolute Maximum Ratings

Symbol	Parameter	Rating	Unit
V <sub>CC</sub>	V <sub>CC</sub> Pin Voltage	V <sub>SS</sub> - 0.3 to V <sub>SS</sub> + 8	V
PV <sub>CC</sub>	PV <sub>CC</sub> Pin Voltage	V <sub>SS</sub> - 0.3 to V <sub>SS</sub> + 8	V
FB	FB Pin Voltage	V <sub>SS</sub> - 0.3 to V <sub>SS</sub> + 8	V
V <sub>CE</sub>	CE Pin Voltage	V <sub>SS</sub> - 0.3 to V <sub>SS</sub> + 8	V
V <sub>SW</sub>	SW Pin Voltage	V <sub>SS</sub> - 0.3 to V <sub>IN</sub> + 0.3	V
P <sub>D</sub>	Power Dissipation	1200	mW
T <sub>OPR</sub>	Operating Temperature Range	-20 to +85	°C
T <sub>STG</sub>	Storage Temperature Range	-20 to +125	°C

Caution: The absolute maximum ratings are rated values exceeding which the product could suffer physical damage. These values must therefore not be exceeded under any conditions.

**Electrical Characteristics** ( $V_{IN} = 5V$ ,  $T_A = +25^{\circ}C$ , unless otherwise specified.)

Symbol	Parameter	Conditions	Min.	Typ.	Max.	Unit
$V_{IN}$	Input Voltage	AP1605 Series	2.5	—	7	V
$V_{REF}$	Internal Reference Voltage	—	1.1625	1.2	1.2375	V
$V_{UVLO}$	UVLO Voltage	Voltage required to maintain $V_{OUT}$	—	—	2.2	V
MAXDTY	Maximum Duty Ratio	—	100	—	—	%
PFMDTY	PFM Duty Ratio	—	15	25	35	%
$I_{SW}$	Switch Current	Duty = 50%	3	—	—	A
$I_{SS}$	Current Consumption $POWER_{ON}$	$V_{OUT} = 2.5V$	—	35	100	$\mu A$
$I_{SSS}$	Current Consumption During Power Off	$V_{ON/OFF} = 0V$	—	—	2	$\mu A$
$\Delta V_{OUT1}$	Line Regulation	2.5V to 7V @ $I_{OUT} = 0.1A$	—	0.2	0.5	%
$\Delta V_{OUT2}$	Load Regulation	0.1A to 3A	—	1	1.5	%
$f_{OSC}$	Oscillation Frequency	—	220	300	380	kHz
$V_{CEH}$	CE Pin "High" Voltage	Evaluate oscillation at SW pin	0.65	—	—	* $V_{CC}$
$V_{CEL}$	CE Pin "Low" Voltage	Evaluate oscillation stop at SW pin	—	—	0.2	
$I_{SH}$	CE Pin Input Leakage Current	—	-0.1	—	0.1	$\mu A$
$I_{SL}$		—	-0.1	—	0.1	$\mu A$
EFFI	Efficiency	$V_{IN} = 5V$ , $V_{OUT} = 2.5V$ , $I_{OUT} = 1A$	—	93	—	%

**Test Circuit**

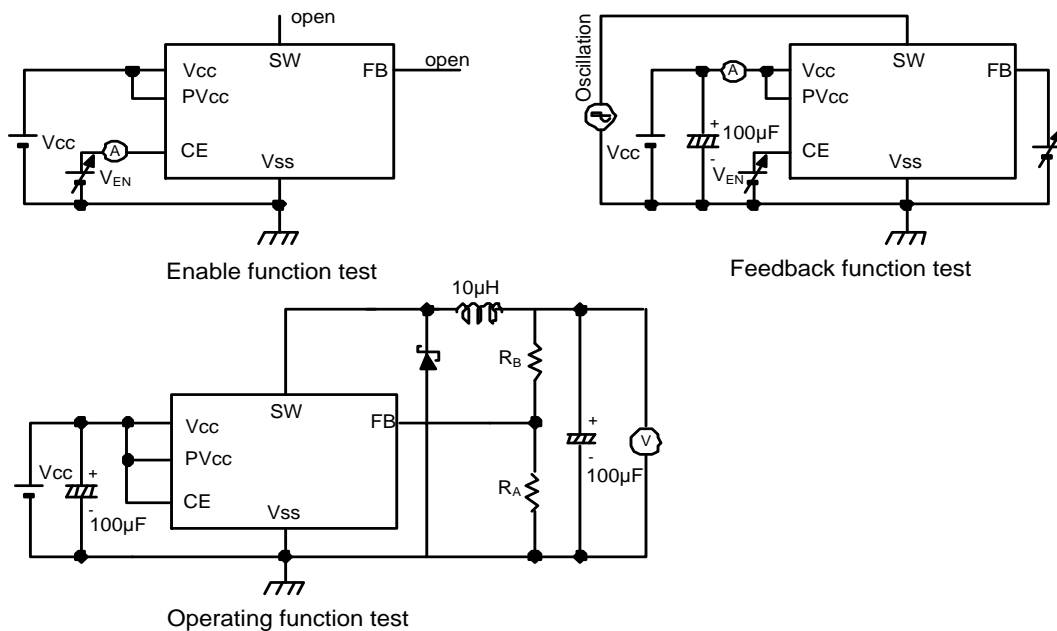

## Functional Description

### PWM/PFM Control (AP1605 Series)

The AP1605 consists of DC/DC converters that employ a PWM/PFM auto-switch system.

In converters of the AP1605, the PFM mode varies in a range of duty cycle from 0% to 25%, and the PWM mode varies in a range of duty cycle from 25% to 100% according to the load current, and yet ripple voltage produced by the switching can easily be removed through a filter because the switching frequency remains constant. Therefore, these converters provide a low-ripple power over broad ranges of input voltage and load current.

## Ordering Information

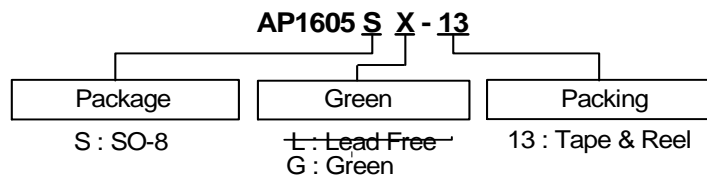

Part Number (Note 4)	Package Code	Package (Note 5)	Green	Quantity	Part Number Suffix		Status (Note 4)
					Tube	13" Tape and Reel	
AP1605SG-13	S	SO-8	Green	2500	NA	-13	In production

Notes: 4. All Lead-Free variants are End of life without replacement.  
 5. For packaging details, go to our website at: <https://www.diodes.com/design/support/packaging/diodes-packaging/diodes-package-outlines-and-pad-layouts/>.

## Marking Information (Note 5)

(1) SO-8

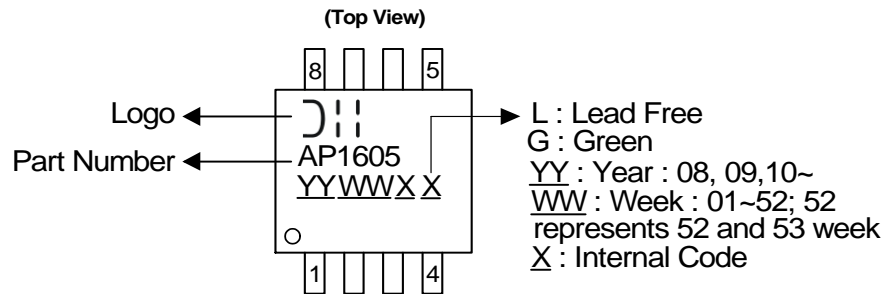

## Package Outline Dimensions

Please see <http://www.diodes.com/package-outlines.html> for the latest version.

### SO-8

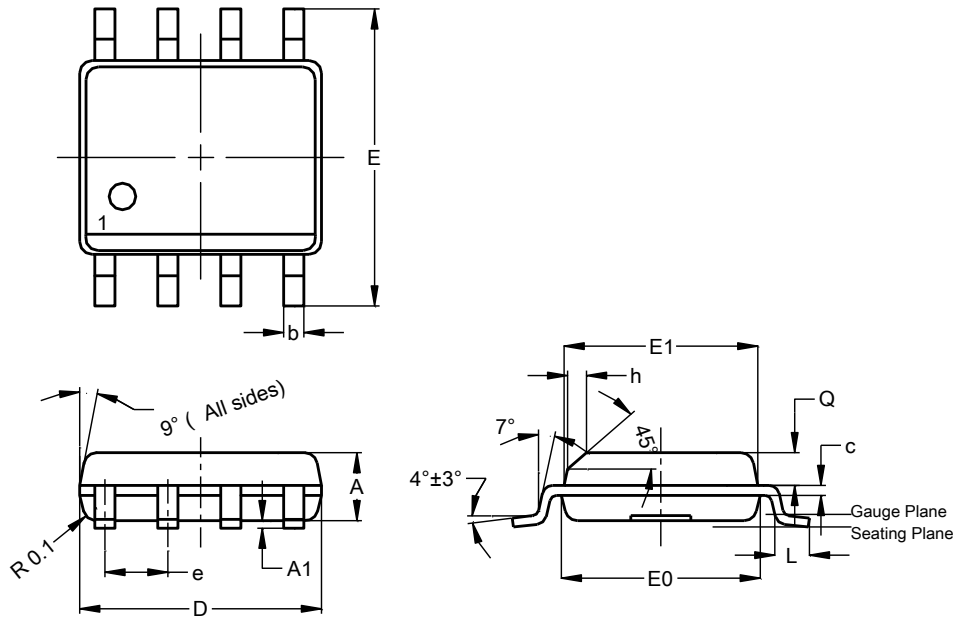

SO-8			
Dim	Min	Max	Typ
A	1.40	1.50	1.45
A1	0.10	0.20	0.15
b	0.30	0.50	0.40
c	0.15	0.25	0.20
D	4.85	4.95	4.90
E	5.90	6.10	6.00
E1	3.80	3.90	3.85
E0	3.85	3.95	3.90
e	--	--	1.27
h	-	--	0.35
L	0.62	0.82	0.72
Q	0.60	0.70	0.65

All Dimensions in mm

## Suggested Pad Layout

Please see <http://www.diodes.com/package-outlines.html> for the latest version.

### SO-8

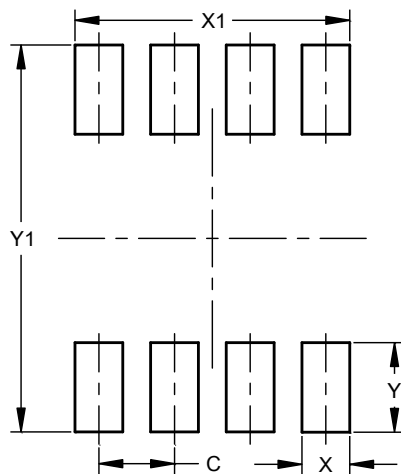

Dimensions	Value (in mm)
C	1.27
X	0.802
X1	4.612
Y	1.505
Y1	6.50

### IMPORTANT NOTICE

DIODES INCORPORATED MAKES NO WARRANTY OF ANY KIND, EXPRESS OR IMPLIED, WITH REGARDS TO THIS DOCUMENT, INCLUDING, BUT NOT LIMITED TO, THE IMPLIED WARRANTIES OF MERCHANTABILITY AND FITNESS FOR A PARTICULAR PURPOSE (AND THEIR EQUIVALENTS UNDER THE LAWS OF ANY JURISDICTION).

Diodes Incorporated and its subsidiaries reserve the right to make modifications, enhancements, improvements, corrections or other changes without further notice to this document and any product described herein. Diodes Incorporated does not assume any liability arising out of the application or use of this document or any product described herein; neither does Diodes Incorporated convey any license under its patent or trademark rights, nor the rights of others. Any Customer or user of this document or products described herein in such applications shall assume all risks of such use and will agree to hold Diodes Incorporated and all the companies whose products are represented on Diodes Incorporated website, harmless against all damages.

Diodes Incorporated does not warrant or accept any liability whatsoever in respect of any products purchased through unauthorized sales channel. Should Customers purchase or use Diodes Incorporated products for any unintended or unauthorized application, Customers shall indemnify and hold Diodes Incorporated and its representatives harmless against all claims, damages, expenses, and attorney fees arising out of, directly or indirectly, any claim of personal injury or death associated with such unintended or unauthorized application.

Products described herein may be covered by one or more United States, international or foreign patents pending. Product names and markings noted herein may also be covered by one or more United States, international or foreign trademarks.

This document is written in English but may be translated into multiple languages for reference. Only the English version of this document is the final and determinative format released by Diodes Incorporated.

### LIFE SUPPORT

Diodes Incorporated products are specifically not authorized for use as critical components in life support devices or systems without the express written approval of the Chief Executive Officer of Diodes Incorporated. As used herein:

A. Life support devices or systems are devices or systems which:

1. are intended to implant into the body, or
2. support or sustain life and whose failure to perform when properly used in accordance with instructions for use provided in the labeling can be reasonably expected to result in significant injury to the user.

B. A critical component is any component in a life support device or system whose failure to perform can be reasonably expected to cause the failure of the life support device or to affect its safety or effectiveness.

Customers represent that they have all necessary expertise in the safety and regulatory ramifications of their life support devices or systems, and acknowledge and agree that they are solely responsible for all legal, regulatory and safety-related requirements concerning their products and any use of Diodes Incorporated products in such safety-critical, life support devices or systems, notwithstanding any devices- or systems-related information or support that may be provided by Diodes Incorporated. Further, Customers must fully indemnify Diodes Incorporated and its representatives against any damages arising out of the use of Diodes Incorporated products in such safety-critical, life support devices or systems.

Copyright © 2017, Diodes Incorporated

[www.diodes.com](http://www.diodes.com)

## Looking for pricing, stock, or lifecycle information?

Click below to explore more details on WIN SOURCE:

 [View AP1605SG-13 on WIN SOURCE](#)

 [Diodes Incorporated](#) Information

## Optimize Your Supply Chain with WIN SOURCE Solutions

-  Global Sourcing Solution
-  Obsolete Management
-  Cost Control Management
-  Shortage Management
-  Alternative Solution
-  Excess Inventory Management