



**THE DATASHEET OF  
SN74CB3Q16211GQLR**



# SN74CB3Q16211 24-Bit Switch 2.5-V/3.3-V Low-Voltage FET Bus Switch

## 1 Features

- Member of the Texas Instruments Widebus® family
- High-bandwidth data path (up to 500 MHz<sup>(1)</sup>)
- 5-V tolerant I/Os with device powered up or powered down
- Low and flat ON-state resistance ( $r_{on}$ ) characteristics over operating range ( $r_{on} = 5 \Omega$  typical)
- Rail-to-rail switching on data I/O ports
  - 0-V to 5-V switching with 3.3-V  $V_{CC}$
  - 0-V to 3.3-V switching with 2.5-V  $V_{CC}$
- Bidirectional data flow, with near-zero propagation delay
- Low input or output capacitance minimizes loading and signal distortion ( $C_{io(OFF)} = 4$  pF typical)
- Fast switching frequency ( $f_{OE} = 20$  MHz maximum)
- Data and control inputs provide undershoot clamp diodes
- Low power consumption ( $I_{CC} = 1$  mA typical)
- $V_{CC}$  operating range from 2.3 V to 3.6 V
- Data I/Os support 0-V to 5-V signaling levels (0.8 V, 1.2 V, 1.5 V, 1.8 V, 2.5 V, 3.3 V, and 5 V)
- Control inputs can be driven by TTL or 5-V/3.3-V CMOS outputs
- $I_{off}$  supports partial-power-down mode operation
- Latch-up Performance Exceeds 100 mA Per JESD 78, Class II
- ESD Performance Tested Per JESD 22
  - 2000-V Human-Body Model (A114-B, Class II)
  - 1000-V Charged-Device Model (C101)
- Supports both digital and analog applications: PCI interface, differential signal interface, memory interleaving, bus isolation, low-distortion signal gating <sup>1</sup>

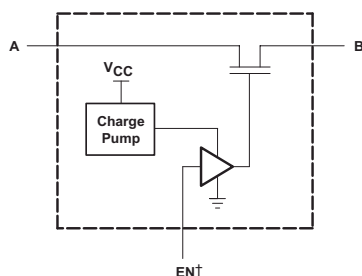

† EN is the internal enable signal applied to the switch.

### Simplified Schematic, Each FET Switch (SW)

## 2 Applications

- AV receiver
- Blu-ray recorder and player
- Embedded PC
- Portable audio dock
- DLP front projection system

## 3 Description

The SN74CB3Q16211 device is a high-bandwidth FET bus switch utilizing a charge pump to elevate the gate voltage of the pass transistor, providing a low and flat ON-state resistance ( $r_{on}$ ). The low and flat ON-state resistance allows for minimal propagation delay and supports rail-to-rail switching on the data input/output (I/O) ports. The device also features low data I/O capacitance to minimize capacitive loading and signal distortion on the data bus. Specifically designed to support high-bandwidth applications, the SN74CB3Q16211 device provides an optimized interface solution ideally suited for broadband communications, networking, and data-intensive computing systems.

### Device Information<sup>(1)</sup>

PART NUMBER	PACKAGE	BODY SIZE
SN74CB3Q16211	TSSOP (56)	14.00 mm × 6.10 mm
	TVSOP (56)	11.30 mm × 4.40 mm
	SSOP (56)	18.40 mm × 7.49 mm
	BGA MICROSTAR JUNIOR (56)	7.00 mm × 4.50 mm

(1) For all available packages, see the orderable addendum at the end of the data sheet.

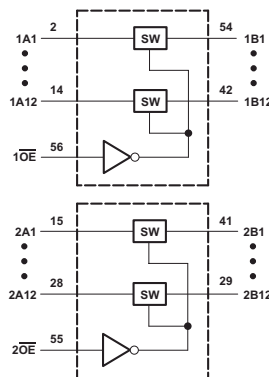

Terminal numbers shown are for the DGG, DGV, and DL packages.

### Logic Diagram (Positive Logic)

<sup>1</sup> For additional information regarding the performance characteristics of the CB3Q family, refer to the TI application report, [CBT-C, CB3T, and CB3Q Signal-Switch Families](#).



## Table of Contents

<b>1 Features</b> .....	1	7.6 Typical Characteristics.....	6
<b>2 Applications</b> .....	1	<b>8 Parameter Measurement Information</b> .....	7
<b>3 Description</b> .....	1	<b>9 Device and Documentation Support</b> .....	8
<b>4 Revision History</b> .....	2	9.1 Documentation Support.....	8
<b>5 Description (continued)</b> .....	2	9.2 Receiving Notification of Documentation Updates.....	8
<b>6 Pin Configuration and Functions</b> .....	3	9.3 Support Resources.....	8
<b>7 Specifications</b> .....	4	9.4 Trademarks.....	8
7.1 Absolute Maximum Ratings.....	4	9.5 Electrostatic Discharge Caution.....	8
7.2 Handling Ratings.....	4	9.6 Glossary.....	8
7.3 Recommended Operating Conditions.....	4	<b>10 Mechanical, Packaging, and Orderable Information</b> .....	8
7.4 Electrical Characteristics.....	5		
7.5 Switching Characteristics.....	5		

## 4 Revision History

NOTE: Page numbers for previous revisions may differ from page numbers in the current version.

Changes from Revision * (May 2004) to Revision A (July 2022)	Page
• Updated document to new TI data sheet format - no specification changes.....	1
• Removed Ordering Information table.....	1
• Added Applications.....	1
• Added Device Information table.....	1
• Updated the numbering format for tables, figures, and cross-references throughout the document.....	1
• Changed the BGA package from: <i>GQL</i> to: <i>ZQL</i> in the <i>Pin Configuration and Functions</i> section.....	3
• Moved $T_{stg}$ to Handling Ratings table.....	4
• Added Mechanical, Packaging, and Orderable Information section.....	8

## 5 Description (continued)

The SN74CB3Q16211 device is organized as two 12-bit bus switches with separate output-enable (1  $\overline{OE}$ , 2  $\overline{OE}$ ) inputs. It can be used as two 12-bit bus switches or as one 24-bit bus switch. When  $\overline{OE}$  is low, the associated 12-bit bus switch is ON and the A port is connected to the B port, allowing bidirectional data flow between ports. When  $\overline{OE}$  is high, the associated 12-bit bus switch is OFF, and a high-impedance state exists between the A and B ports.

This device is fully specified for partial-power-down applications using  $I_{off}$ . The  $I_{off}$  circuitry prevents damaging current backflow through the device when it is powered down.

To ensure the high-impedance state during power up or power down,  $\overline{OE}$  should be tied to  $V_{CC}$  through a pullup resistor; the minimum value of the resistor is determined by the current-sinking capability of the driver.

**Table 5-1. Function Table  
(Each 12-Bit Bus Switch)**

INPUT $\overline{OE}$	INPUT/OUTPUT A	FUNCTION
L	B	A port = B port
H	Z	Disconnect

## 6 Pin Configuration and Functions

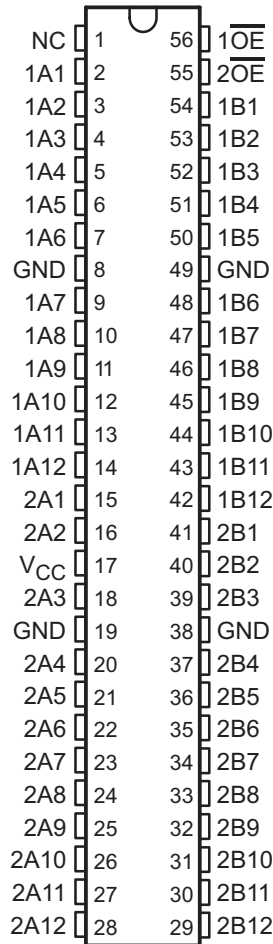

NC – No internal connection

**Figure 6-1. DGG, DGV, or DL Package, 56-Pin TSSOP and TVSOP (Top View)**

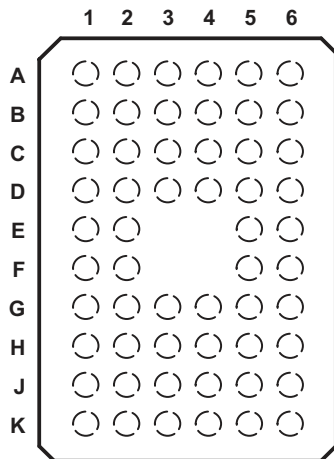

	1	2	3	4	5	6
A	1A2	1A1	NC	$\overline{1OE}$	$\overline{2OE}$	1B1
B	1A5	1A4	1A3	1B2	1B3	1B4
C	1A7	GND	1A6	1B5	GND	1B6
D	1A10	1A8	1A9	1B8	1B7	1B9
E	1A12	1A11			1B10	1B11
F	2A1	2A2			2B1	1B12
G	V <sub>CC</sub>	GND	2A3	2B3	GND	2B2
H	2A4	2A5	2A6	2B6	2B5	2B4
J	2A7	2A8	2A9	2B9	2B8	2B7
K	2A10	2A11	2A12	2B12	2B11	2B10

NC – No internal connection

**Figure 6-3. Functions Table**

**Figure 6-2. ZQL Package, 56-Pin BGA (Top View)**

## 7 Specifications

### 7.1 Absolute Maximum Ratings

over operating free-air temperature range (unless otherwise noted)<sup>(1)</sup>

		MIN	MAX	UNIT
V <sub>CC</sub>	Supply voltage range <sup>(2)</sup>	-0.5	4.6	V
V <sub>IN</sub>	Control input voltage range <sup>(2) (3)</sup>	-0.5	7	V
V <sub>I/O</sub>	Switch I/O voltage range <sup>(2) (3) (4)</sup>	-0.5	7	V
I <sub>IK</sub>	Control input clamp current	V <sub>IN</sub> < 0		-50 mA
I <sub>I/O</sub>	I/O port clamp current	V <sub>I/O</sub> < 0		-50 mA
I <sub>I/O</sub>	ON-state switch current <sup>(5)</sup>			±64 mA
Continuous current through V <sub>CC</sub> or GND terminals				±100 mA
θ <sub>JA</sub>	Package thermal impedance <sup>(6)</sup>	DGG package		64
		DGV package		48
		DL package		56
		GQL package		42

- (1) Stresses beyond those listed under *Absolute Maximum Ratings* may cause permanent damage to the device. These are stress ratings only, and functional operation of the device at these or any other conditions beyond those indicated under *Recommended Operating Conditions* is not implied. Exposure to absolute-maximum-rated conditions for extended periods may affect device reliability.
- (2) All voltages are with respect to ground unless otherwise specified.
- (3) The input and output voltage ratings may be exceeded if the input and output clamp-current ratings are observed.
- (4) V<sub>I</sub> and V<sub>O</sub> are used to denote specific conditions for V<sub>I/O</sub>.
- (5) I<sub>I</sub> and I<sub>O</sub> are used to denote specific conditions for I<sub>I/O</sub>.
- (6) The package thermal impedance is calculated in accordance with JESD 51-7.

### 7.2 Handling Ratings

PARAMETER	DEFINITION	MIN	MAX	UNIT
T <sub>stg</sub>	Storage temperature range	-65	150	°C

### 7.3 Recommended Operating Conditions

over operating free-air temperature range (unless otherwise noted)<sup>(1)</sup>

		MIN	MAX	UNIT	
V <sub>CC</sub>	Supply voltage	2.3	3.6	V	
V <sub>IH</sub>	High-level control input voltage	V <sub>CC</sub> = 2.3 V to 2.7 V	1.7	5.5	V
		V <sub>CC</sub> = 2.7 V to 3.6 V	2	5.5	
V <sub>IL</sub>	Low-level control input voltage	V <sub>CC</sub> = 2.3 V to 2.7 V	0	0.7	V
		V <sub>CC</sub> = 2.7 V to 3.6 V	0	0.8	
V <sub>I/O</sub>	Data input/output voltage	0	5.5	V	
T <sub>A</sub>	Operating free-air temperature	-40	85	°C	

- (1) All unused control inputs of the device must be held at V<sub>CC</sub> or GND to ensure proper device operation. Refer to the TI application report, *Implications of Slow or Floating CMOS Inputs*, literature number [SCBA004](#).

## 7.4 Electrical Characteristics

over recommended operating free-air temperature range (unless otherwise noted)<sup>(1)</sup>

PARAMETER		TEST CONDITIONS		MIN	TYP <sup>(2)</sup>	MAX	UNIT
$V_{IK}$		$V_{CC} = 3.6\text{ V}$ ,	$I_I = -18\text{ mA}$			-1.8	V
$I_{IN}$	Control inputs	$V_{CC} = 3.6\text{ V}$ ,	$V_{IN} = 0\text{ to }5.5\text{ V}$			$\pm 1$	$\mu\text{A}$
$I_{OZ}$ <sup>(3)</sup>		$V_{CC} = 3.6\text{ V}$ ,	$V_O = 0\text{ to }5.5\text{ V}$ , $V_I = 0$			$\pm 1$	$\mu\text{A}$
$I_{off}$		$V_{CC} = 0$ ,	$V_O = 0\text{ to }5.5\text{ V}$ , $V_I = 0$			1	$\mu\text{A}$
$I_{CC}$		$V_{CC} = 3.6\text{ V}$ ,	$I_{I/O} = 0$ ,		1	3	mA
$\Delta I_{CC}$ <sup>(4)</sup>	Control inputs	$V_{CC} = 3.6\text{ V}$ ,	One input at 3 V, Other inputs at $V_{CC}$ or GND			30	$\mu\text{A}$
$I_{CCD}$ <sup>(5)</sup>		$V_{CC} = 3.6\text{ V}$ ,	A and B ports open, Control input switching at 50% duty cycle		0.15	0.25	mA/ MHz
$C_{in}$	Control inputs	$V_{CC} = 3.3\text{ V}$ ,	$V_{IN} = 5.5\text{ V}$ , 3.3 V, or 0		3.5	5	pF
$C_{io(OFF)}$		$V_{CC} = 3.3\text{ V}$ ,	$V_{IN} = V_{CC}$ or GND, Switch OFF, $V_{I/O} = 5.5\text{ V}$ , 3.3 V, or 0		4	5	pF
$C_{io(ON)}$		$V_{CC} = 3.3\text{ V}$ ,	$V_{IN} = V_{CC}$ or GND, Switch ON, $V_{I/O} = 5.5\text{ V}$ , 3.3 V, or 0		10	12.5	pF
$r_{on}$ <sup>(6)</sup>	$V_{CC} = 2.3\text{ V}$ , TYP at $V_{CC} = 2.5\text{ V}$	$V_I = 0$ ,	$I_O = 30\text{ mA}$	5	8	$\Omega$	
		$V_I = 1.7\text{ V}$ ,	$I_O = -15\text{ mA}$	5	9		
	$V_{CC} = 3\text{ V}$	$V_I = 0$ ,	$I_O = 30\text{ mA}$	5	6.5		
		$V_I = 2.4\text{ V}$ ,	$I_O = -15\text{ mA}$	5	8		

- (1)  $V_{IN}$  and  $I_{IN}$  refer to control inputs.  $V_I$ ,  $V_O$ ,  $I_I$ , and  $I_O$  refer to data pins.
- (2) All typical values are at  $V_{CC} = 3.3\text{ V}$  (unless otherwise noted),  $T_A = 25^\circ\text{C}$ .
- (3) For I/O ports, the parameter  $I_{OZ}$  includes the input leakage current.
- (4) This is the increase in supply current for each input that is at the specified TTL voltage level, rather than  $V_{CC}$  or GND.
- (5) This parameter specifies the dynamic power-supply current associated with the operating frequency of a single control input (see Figure 7-2).
- (6) Measured by the voltage drop between the A and B terminals at the indicated current through the switch. ON-state resistance is determined by the lower of the voltages of the two (A or B) terminals.

## 7.5 Switching Characteristics

over recommended operating free-air temperature range (unless otherwise noted) (see Figure 8-1)

PARAMETER	FROM (INPUT)	TO (OUTPUT)	$V_{CC} = 2.5\text{ V} \pm 0.2\text{ V}$		$V_{CC} = 3.3\text{ V} \pm 0.3\text{ V}$		UNIT
			MIN	MAX	MIN	MAX	
$f_{OE}$ <sup>(1)</sup>	$\overline{OE}$	A or B		10		20	MHz
$t_{pd}$ <sup>(2)</sup>	A or B	B or A		0.15		0.25	ns
$t_{en}$	$\overline{OE}$	A or B	1.5	8	1.5	8	ns
$t_{dis}$	$\overline{OE}$	A or B	1	7.5	1	7.5	ns

- (1) Maximum switching frequency for control input ( $V_O > V_{CC}$ ,  $V_I = 5\text{ V}$ ,  $R_L \geq 1\text{ M}\Omega$ ,  $C_L = 0$ ).
- (2) The propagation delay is the calculated RC time constant of the typical ON-state resistance of the switch and the specified load capacitance, when driven by an ideal voltage source (zero output impedance).

## 7.6 Typical Characteristics

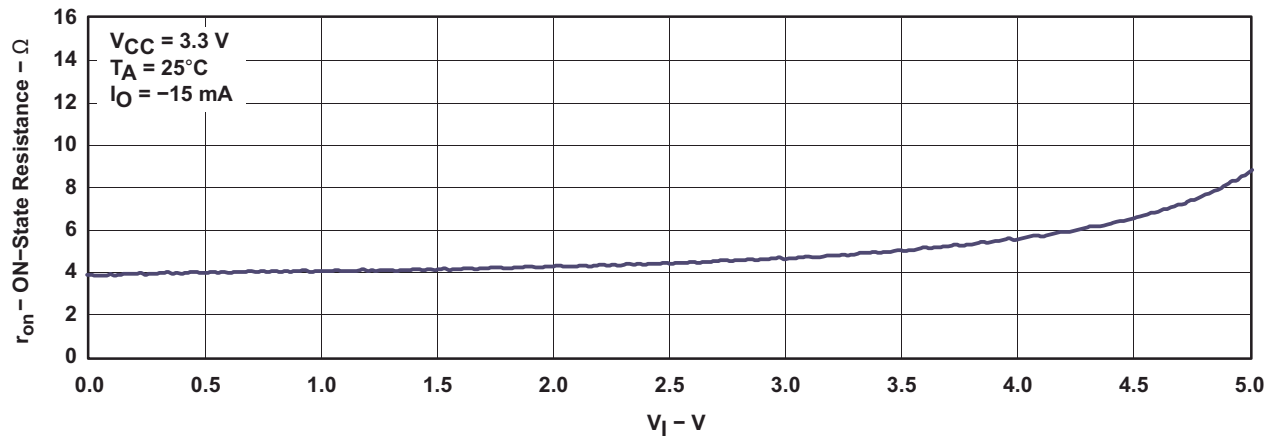

Figure 7-1. Typical  $r_{on}$  vs  $V_I$

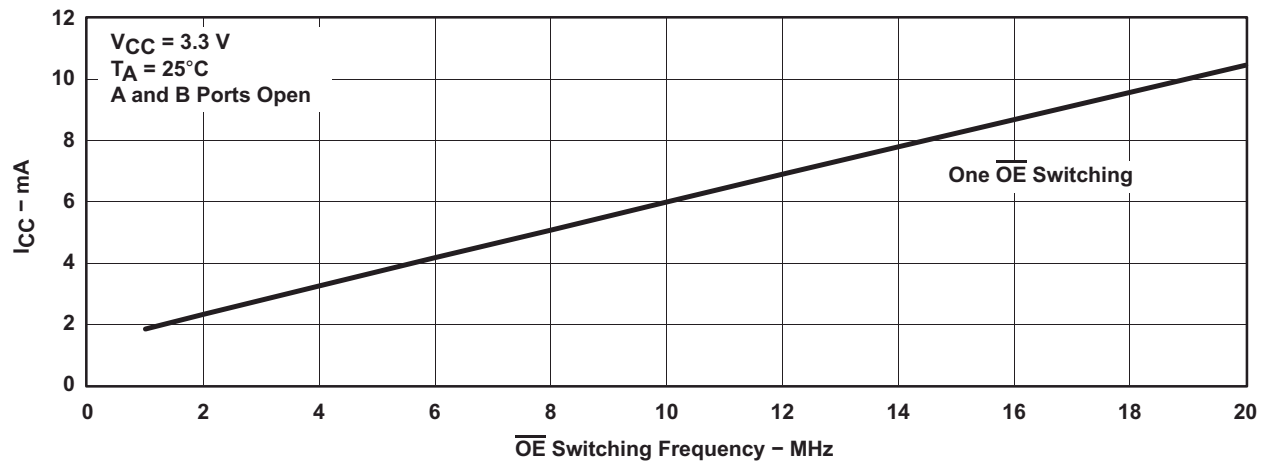
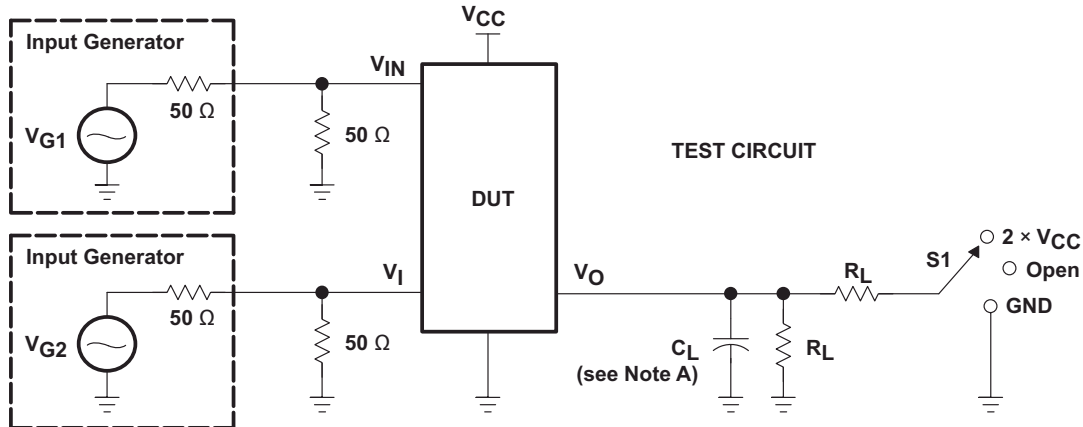
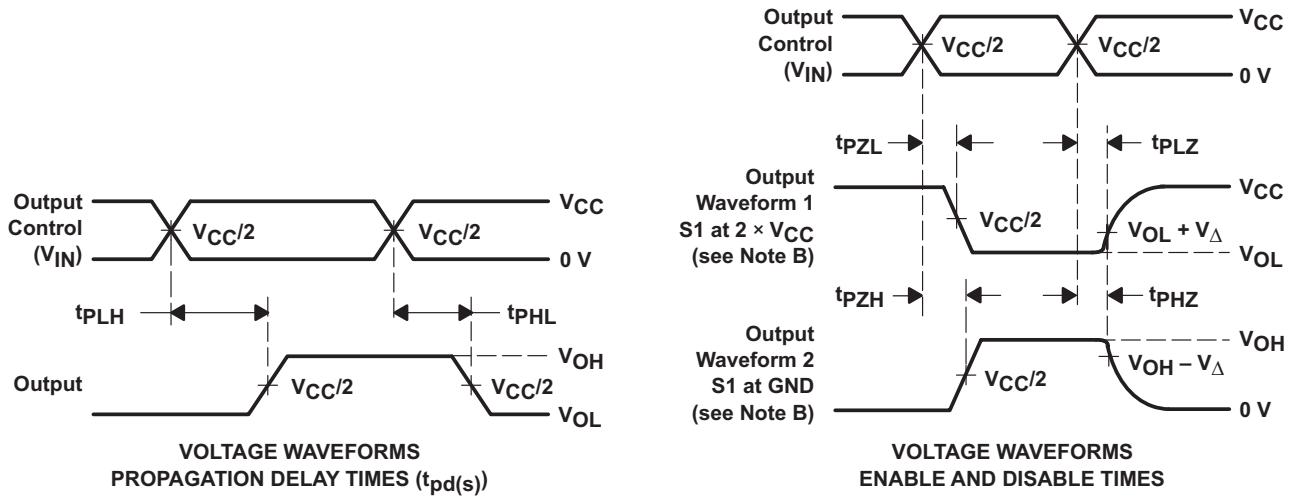

Figure 7-2. Typical  $I_{CC}$  vs  $\overline{OE}$  Switching Frequency

## 8 Parameter Measurement Information



TEST	VCC	S1	RL	VI	CL	VΔ
t <sub>pd</sub> (s)	2.5 V ± 0.2 V	Open	500 Ω	VCC or GND	30 pF	
	3.3 V ± 0.3 V	Open	500 Ω	VCC or GND	50 pF	
t <sub>PLZ</sub> /t <sub>PZL</sub>	2.5 V ± 0.2 V	2 × VCC	500 Ω	GND	30 pF	0.15 V
	3.3 V ± 0.3 V	2 × VCC	500 Ω	GND	50 pF	0.3 V
t <sub>PHZ</sub> /t <sub>PZH</sub>	2.5 V ± 0.2 V	GND	500 Ω	VCC	30 pF	0.15 V
	3.3 V ± 0.3 V	GND	500 Ω	VCC	50 pF	0.3 V



- NOTES:
- A.  $C_L$  includes probe and jig capacitance.
  - B. Waveform 1 is for an output with internal conditions such that the output is low, except when disabled by the output control. Waveform 2 is for an output with internal conditions such that the output is high, except when disabled by the output control.
  - C. All input pulses are supplied by generators having the following characteristics:  $PRR \leq 10$  MHz,  $Z_O = 50 \Omega$ ,  $t_r \leq 2.5$  ns,  $t_f \leq 2.5$  ns.
  - D. The outputs are measured one at a time, with one transition per measurement.
  - E.  $t_{PLZ}$  and  $t_{PHZ}$  are the same as  $t_{dis}$ .
  - F.  $t_{PZL}$  and  $t_{PZH}$  are the same as  $t_{en}$ .
  - G.  $t_{PLH}$  and  $t_{PHL}$  are the same as  $t_{pd}(s)$ . The  $t_{pd}$  propagation delay is the calculated RC time constant of the typical ON-state resistance of the switch and the specified load capacitance, when driven by an ideal voltage source (zero output impedance).
  - H. All parameters and waveforms are not applicable to all devices.

Figure 8-1. Test Circuit and Voltage Waveforms

## 9 Device and Documentation Support

### 9.1 Documentation Support

#### 9.1.1 Related Documentation

For related documentation, see the following:

- Texas Instruments, [CBT-C, CB3T, and CB3Q Signal-Switch Families application report](#)

### 9.2 Receiving Notification of Documentation Updates

To receive notification of documentation updates, navigate to the device product folder on [ti.com](#). Click on *Subscribe to updates* to register and receive a weekly digest of any product information that has changed. For change details, review the revision history included in any revised document.

### 9.3 Support Resources

[TI E2E™ support forums](#) are an engineer's go-to source for fast, verified answers and design help — straight from the experts. Search existing answers or ask your own question to get the quick design help you need.

Linked content is provided "AS IS" by the respective contributors. They do not constitute TI specifications and do not necessarily reflect TI's views; see TI's [Terms of Use](#).

### 9.4 Trademarks

TI E2E™ is a trademark of Texas Instruments.

Widebus® is a registered trademark of Texas Instruments.

All trademarks are the property of their respective owners.

### 9.5 Electrostatic Discharge Caution



This integrated circuit can be damaged by ESD. Texas Instruments recommends that all integrated circuits be handled with appropriate precautions. Failure to observe proper handling and installation procedures can cause damage.

ESD damage can range from subtle performance degradation to complete device failure. Precision integrated circuits may be more susceptible to damage because very small parametric changes could cause the device not to meet its published specifications.

### 9.6 Glossary

[TI Glossary](#) This glossary lists and explains terms, acronyms, and definitions.

## 10 Mechanical, Packaging, and Orderable Information

The following pages include mechanical packaging and orderable information. This information is the most current data available for the designated devices. This data is subject to change without notice and revision of this document. For browser based versions of this data sheet, refer to the left hand navigation.

**PACKAGING INFORMATION**

Orderable Device	Status (1)	Package Type	Package Drawing	Pins	Package Qty	Eco Plan (2)	Lead finish/ Ball material (6)	MSL Peak Temp (3)	Op Temp (°C)	Device Marking (4/5)	Samples
SN74CB3Q16211DGGR	ACTIVE	TSSOP	DGG	56	2000	RoHS & Green	NIPDAU	Level-1-260C-UNLIM	-40 to 85	CB3Q16211	<a href="#">Samples</a>
SN74CB3Q16211DGVR	ACTIVE	TVSOP	DGV	56	2000	RoHS & Green	NIPDAU	Level-1-260C-UNLIM	-40 to 85	BW211	<a href="#">Samples</a>
SN74CB3Q16211DL	ACTIVE	SSOP	DL	56	20	RoHS & Green	NIPDAU	Level-1-260C-UNLIM	-40 to 85	CB3Q16211	<a href="#">Samples</a>
SN74CB3Q16211DLR	ACTIVE	SSOP	DL	56	1000	RoHS & Green	NIPDAU	Level-1-260C-UNLIM	-40 to 85	CB3Q16211	<a href="#">Samples</a>

(1) The marketing status values are defined as follows:

**ACTIVE:** Product device recommended for new designs.

**LIFEBUY:** TI has announced that the device will be discontinued, and a lifetime-buy period is in effect.

**NRND:** Not recommended for new designs. Device is in production to support existing customers, but TI does not recommend using this part in a new design.

**PREVIEW:** Device has been announced but is not in production. Samples may or may not be available.

**OBSELETE:** TI has discontinued the production of the device.

(2) **RoHS:** TI defines "RoHS" to mean semiconductor products that are compliant with the current EU RoHS requirements for all 10 RoHS substances, including the requirement that RoHS substance do not exceed 0.1% by weight in homogeneous materials. Where designed to be soldered at high temperatures, "RoHS" products are suitable for use in specified lead-free processes. TI may reference these types of products as "Pb-Free".

**RoHS Exempt:** TI defines "RoHS Exempt" to mean products that contain lead but are compliant with EU RoHS pursuant to a specific EU RoHS exemption.

**Green:** TI defines "Green" to mean the content of Chlorine (Cl) and Bromine (Br) based flame retardants meet JS709B low halogen requirements of <=1000ppm threshold. Antimony trioxide based flame retardants must also meet the <=1000ppm threshold requirement.

(3) MSL, Peak Temp. - The Moisture Sensitivity Level rating according to the JEDEC industry standard classifications, and peak solder temperature.

(4) There may be additional marking, which relates to the logo, the lot trace code information, or the environmental category on the device.

(5) Multiple Device Markings will be inside parentheses. Only one Device Marking contained in parentheses and separated by a "-" will appear on a device. If a line is indented then it is a continuation of the previous line and the two combined represent the entire Device Marking for that device.

(6) Lead finish/Ball material - Orderable Devices may have multiple material finish options. Finish options are separated by a vertical ruled line. Lead finish/Ball material values may wrap to two lines if the finish value exceeds the maximum column width.

**Important Information and Disclaimer:**The information provided on this page represents TI's knowledge and belief as of the date that it is provided. TI bases its knowledge and belief on information provided by third parties, and makes no representation or warranty as to the accuracy of such information. Efforts are underway to better integrate information from third parties. TI has taken and

continues to take reasonable steps to provide representative and accurate information but may not have conducted destructive testing or chemical analysis on incoming materials and chemicals. TI and TI suppliers consider certain information to be proprietary, and thus CAS numbers and other limited information may not be available for release.

In no event shall TI's liability arising out of such information exceed the total purchase price of the TI part(s) at issue in this document sold by TI to Customer on an annual basis.

**TAPE AND REEL INFORMATION**

**QUADRANT ASSIGNMENTS FOR PIN 1 ORIENTATION IN TAPE**

\*All dimensions are nominal

Device	Package Type	Package Drawing	Pins	SPQ	Reel Diameter (mm)	Reel Width W1 (mm)	A0 (mm)	B0 (mm)	K0 (mm)	P1 (mm)	W (mm)	Pin1 Quadrant
SN74CB3Q16211DGGR	TSSOP	DGG	56	2000	330.0	24.4	8.6	15.6	1.8	12.0	24.0	Q1
SN74CB3Q16211DGVR	TVSOP	DGV	56	2000	330.0	24.4	6.8	11.7	1.6	12.0	24.0	Q1
SN74CB3Q16211DLR	SSOP	DL	56	1000	330.0	32.4	11.35	18.67	3.1	16.0	32.0	Q1

**TAPE AND REEL BOX DIMENSIONS**

\*All dimensions are nominal

Device	Package Type	Package Drawing	Pins	SPQ	Length (mm)	Width (mm)	Height (mm)
SN74CB3Q16211DGGR	TSSOP	DGG	56	2000	367.0	367.0	45.0
SN74CB3Q16211DGVR	TVSOP	DGV	56	2000	367.0	367.0	45.0
SN74CB3Q16211DLR	SSOP	DL	56	1000	367.0	367.0	55.0

**TUBE**

\*All dimensions are nominal

Device	Package Name	Package Type	Pins	SPQ	L (mm)	W (mm)	T (μm)	B (mm)
SN74CB3Q16211DL	DL	SSOP	56	20	473.7	14.24	5110	7.87



# EXAMPLE BOARD LAYOUT

DGV0056A

TVSOP - 1.2 mm max height

SMALL OUTLINE PACKAGE

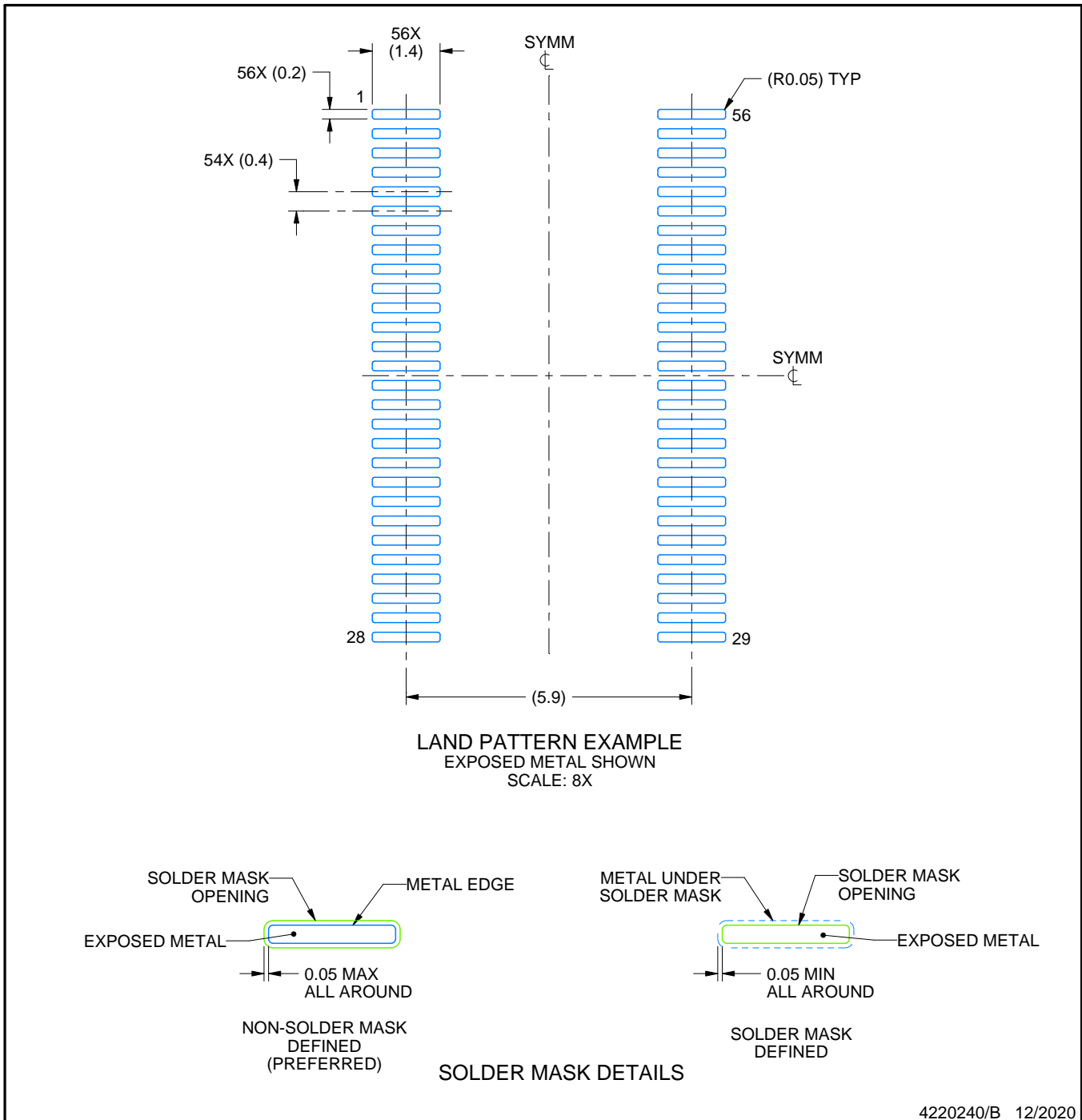

NOTES: (continued)

6. Publication IPC-7351 may have alternate designs.
7. Solder mask tolerances between and around signal pads can vary based on board fabrication site.

# EXAMPLE STENCIL DESIGN

DGV0056A

TVSOP - 1.2 mm max height

SMALL OUTLINE PACKAGE

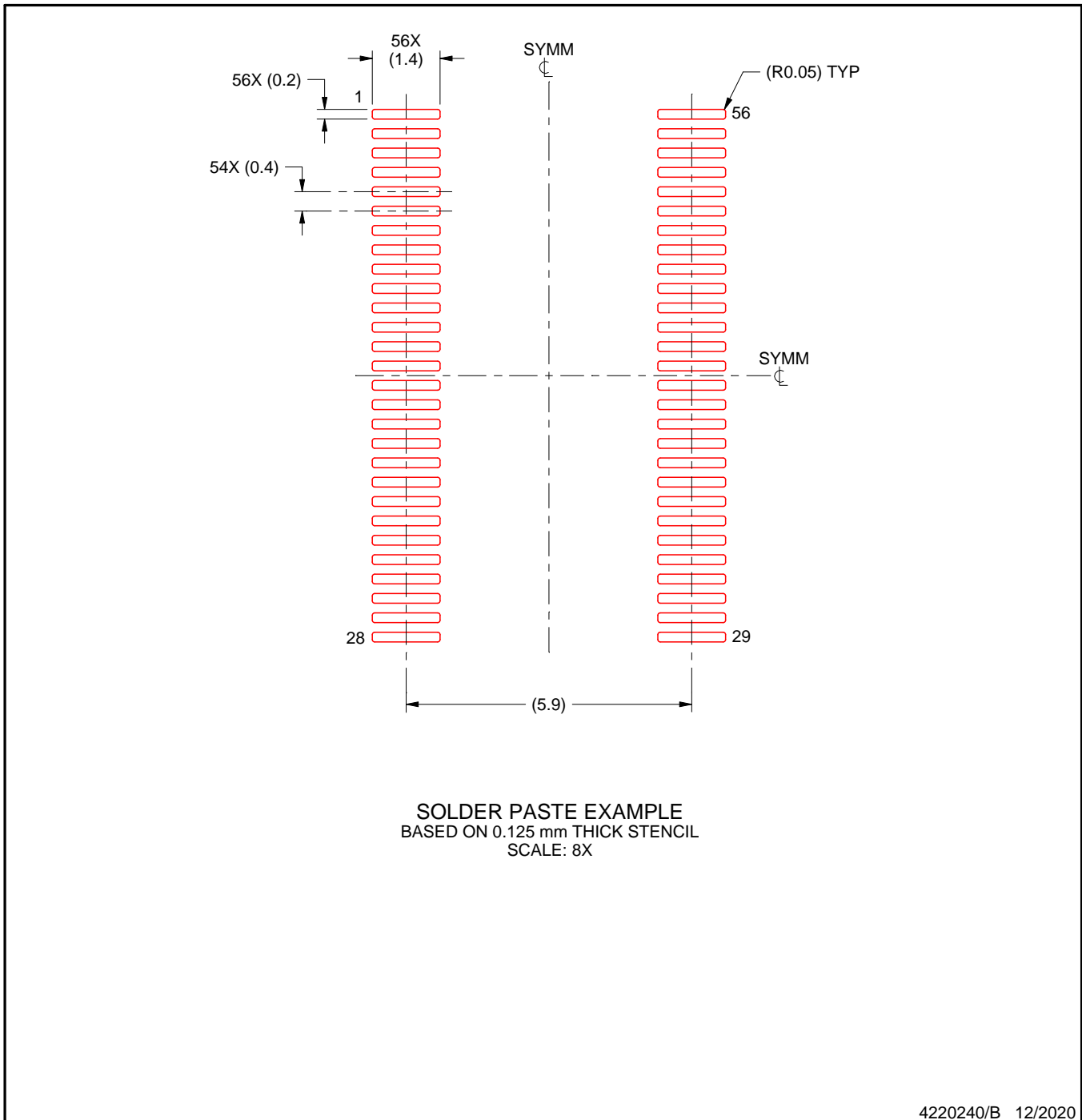

NOTES: (continued)

8. Laser cutting apertures with trapezoidal walls and rounded corners may offer better paste release. IPC-7525 may have alternate design recommendations.
9. Board assembly site may have different recommendations for stencil design.



# DGG0056A



# PACKAGE OUTLINE

## TSSOP - 1.2 mm max height

SMALL OUTLINE PACKAGE

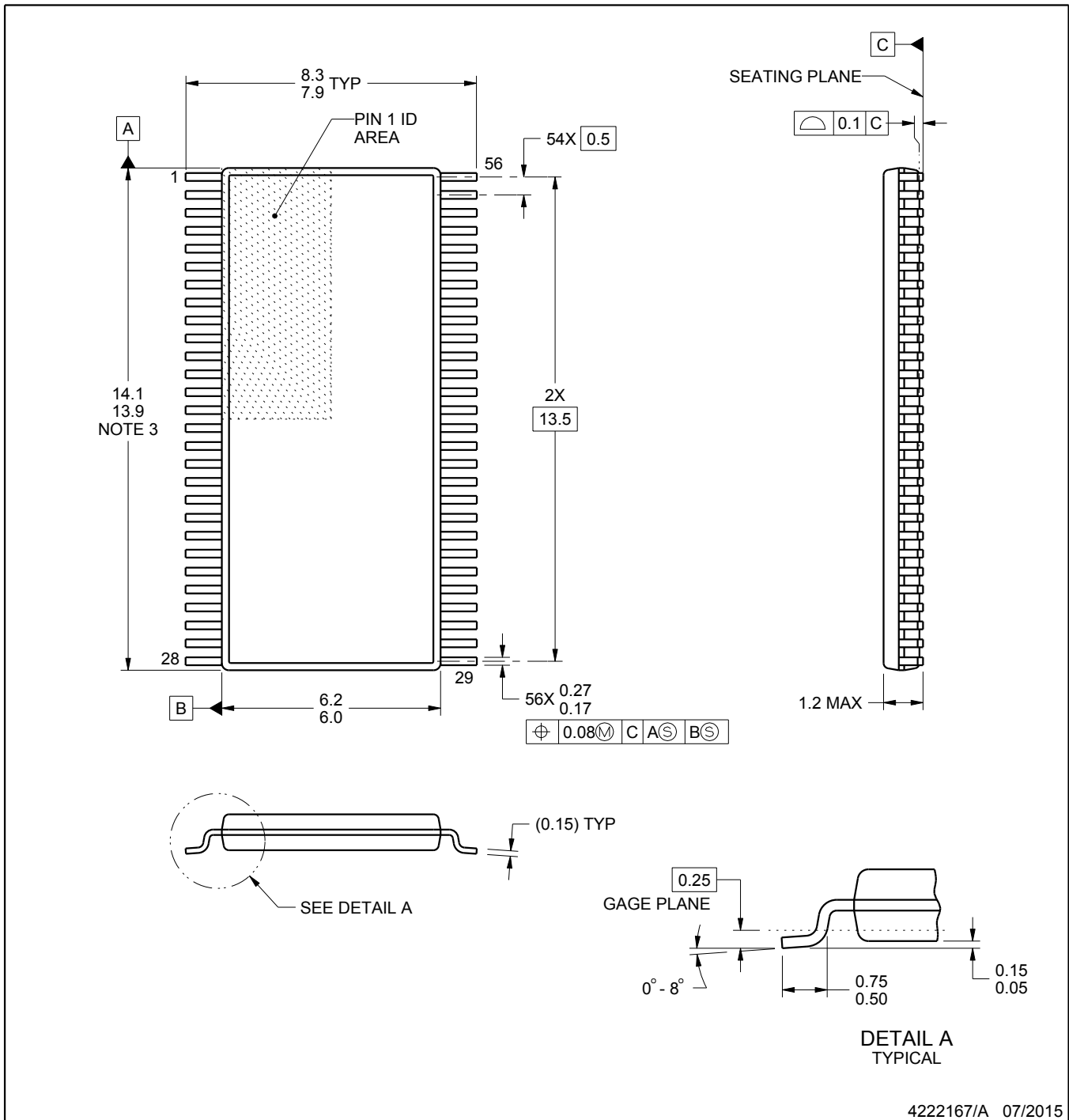

4222167/A 07/2015

### NOTES:

- All linear dimensions are in millimeters. Any dimensions in parenthesis are for reference only. Dimensioning and tolerancing per ASME Y14.5M.
- This drawing is subject to change without notice.
- This dimension does not include mold flash, protrusions, or gate burrs. Mold flash, protrusions, or gate burrs shall not exceed 0.15 mm per side.
- Reference JEDEC registration MO-153.

# EXAMPLE BOARD LAYOUT

DGG0056A

TSSOP - 1.2 mm max height

SMALL OUTLINE PACKAGE

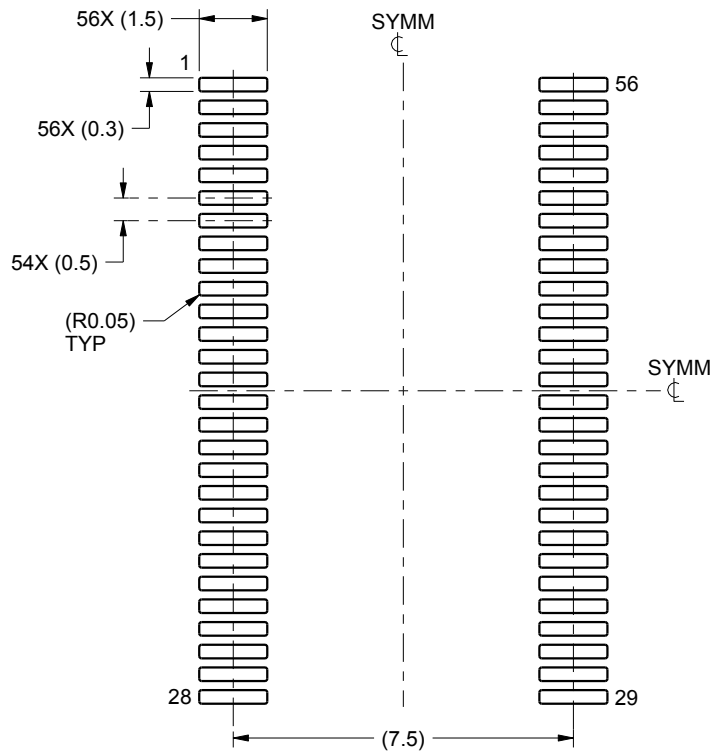

LAND PATTERN EXAMPLE  
SCALE:6X

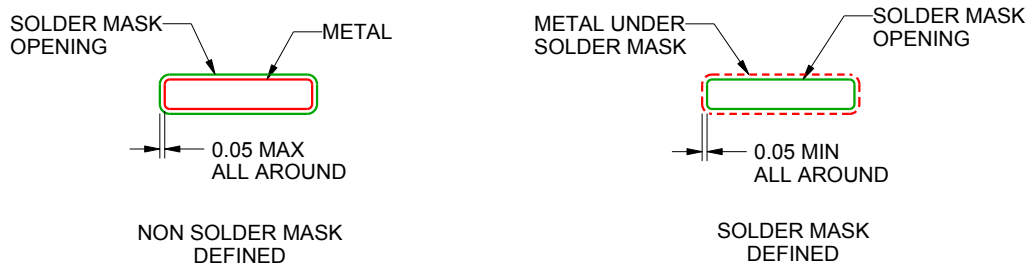

SOLDER MASK DETAILS

4222167/A 07/2015

NOTES: (continued)

- 5. Publication IPC-7351 may have alternate designs.
- 6. Solder mask tolerances between and around signal pads can vary based on board fabrication site.

# EXAMPLE STENCIL DESIGN

DGG0056A

TSSOP - 1.2 mm max height

SMALL OUTLINE PACKAGE

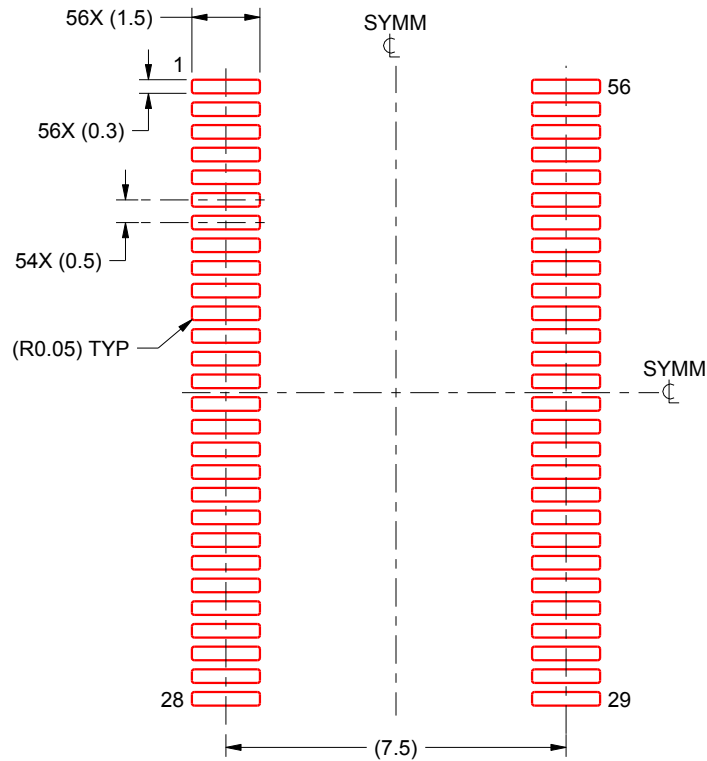

SOLDER PASTE EXAMPLE  
BASED ON 0.125 mm THICK STENCIL  
SCALE:6X

4222167/A 07/2015

NOTES: (continued)

7. Laser cutting apertures with trapezoidal walls and rounded corners may offer better paste release. IPC-7525 may have alternate design recommendations.
8. Board assembly site may have different recommendations for stencil design.

## IMPORTANT NOTICE AND DISCLAIMER

TI PROVIDES TECHNICAL AND RELIABILITY DATA (INCLUDING DATA SHEETS), DESIGN RESOURCES (INCLUDING REFERENCE DESIGNS), APPLICATION OR OTHER DESIGN ADVICE, WEB TOOLS, SAFETY INFORMATION, AND OTHER RESOURCES "AS IS" AND WITH ALL FAULTS, AND DISCLAIMS ALL WARRANTIES, EXPRESS AND IMPLIED, INCLUDING WITHOUT LIMITATION ANY IMPLIED WARRANTIES OF MERCHANTABILITY, FITNESS FOR A PARTICULAR PURPOSE OR NON-INFRINGEMENT OF THIRD PARTY INTELLECTUAL PROPERTY RIGHTS.

These resources are intended for skilled developers designing with TI products. You are solely responsible for (1) selecting the appropriate TI products for your application, (2) designing, validating and testing your application, and (3) ensuring your application meets applicable standards, and any other safety, security, regulatory or other requirements.

These resources are subject to change without notice. TI grants you permission to use these resources only for development of an application that uses the TI products described in the resource. Other reproduction and display of these resources is prohibited. No license is granted to any other TI intellectual property right or to any third party intellectual property right. TI disclaims responsibility for, and you will fully indemnify TI and its representatives against, any claims, damages, costs, losses, and liabilities arising out of your use of these resources.

TI's products are provided subject to [TI's Terms of Sale](#) or other applicable terms available either on [ti.com](http://ti.com) or provided in conjunction with such TI products. TI's provision of these resources does not expand or otherwise alter TI's applicable warranties or warranty disclaimers for TI products.

TI objects to and rejects any additional or different terms you may have proposed.

Mailing Address: Texas Instruments, Post Office Box 655303, Dallas, Texas 75265  
Copyright © 2022, Texas Instruments Incorporated

## Looking for pricing, stock, or lifecycle information?

Click below to explore more details on WIN SOURCE:

 [View SN74CB3Q16211GQLR on WIN SOURCE](#)

 [Texas Instruments](#) Information

## Optimize Your Supply Chain with WIN SOURCE Solutions

-  Global Sourcing Solution
-  Obsolete Management
-  Cost Control Management
-  Shortage Management
-  Alternative Solution
-  Excess Inventory Management