



**THE DATASHEET OF  
NM27C512V120**





## Connection Diagrams

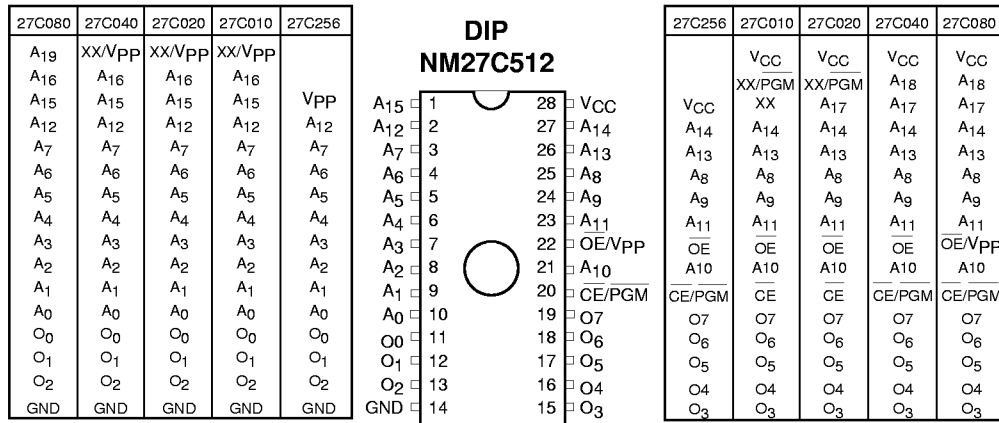

DS010834-2

Compatible EPROM pin configurations are shown in the blocks adjacement to the NM27C512 pins.

### Commercial Temp Range (0°C to +70°C)

Parameter/Order Number	Access Time (ns)
NM27C512 Q, N, V 90	90
NM27C512 Q, N, V 120	120
NM27C512 Q, N, V 150	150

### Pin Names

A0–A15	Addresses
CE/PGM	Chip Enable/Program
OE	Output Enable
O0–O7	Outputs
NC	Don't Care (During Read)

### Industrial Temp Range (-40°C to +85°C)

Parameter/Order Number	Access Time (ns)
NM27C512 QE, NE, VE 120	120
NM27C512 QE, NE, VE 150	150

Q = Quartz-Windowed Ceramic DIP Package

N = Plastic DIP Package

V = PLCC Package

- All packages conform to the JEDEC standard.
- All versions are guaranteed to function for slower speeds.

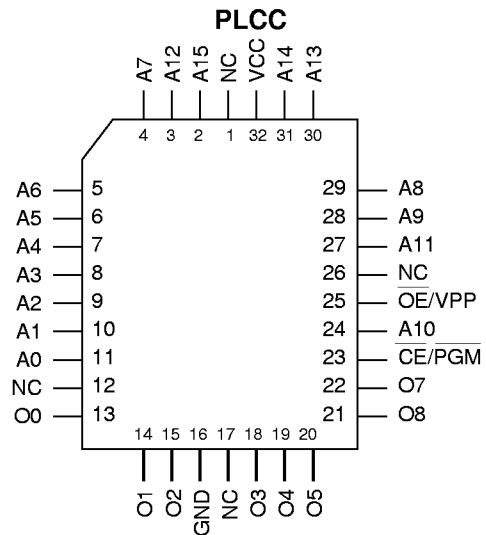

DS010834-3

### Absolute Maximum Ratings (Note 1)

Storage Temperature	-65°C to +150°C
All Input Voltages Except A9 with Respect to Ground	-0.6V to +7V
V <sub>PP</sub> and A9 with Respect to Ground	-0.7V to +14V
V <sub>CC</sub> Supply Voltage with Respect to Ground	-0.6V to +7V

ESD Protection (MIL Std. 883, Method 3015.2)	>2000V
All Output Voltages with Respect to Ground	V <sub>CC</sub> + 1.0V to GND -0.6V

### Operating Range

Range	Temperature	V <sub>CC</sub>	Tolerance
Commercial	0°C to +70°C	+5V	±10%
Industrial	-40°C to +85°C	+5V	±10%

## Read Operation

### DC Electrical Characteristics

Symbol	Parameter	Test Conditions	Min	Max	Units
V <sub>IL</sub>	Input Low Level		-0.5	0.8	V
V <sub>IH</sub>	Input High Level		2.0	V <sub>CC</sub> + 1	V
V <sub>OL</sub>	Output Low Voltage	I <sub>OL</sub> = 2.1 mA		0.4	V
V <sub>OH</sub>	Output High Voltage	I <sub>OH</sub> = -2.5 mA	3.5		V
I <sub>SB1</sub>	V <sub>CC</sub> Standby Current (CMOS)	$\overline{CE} = V_{CC} \pm 0.3V$		100	μA
I <sub>SB2</sub>	V <sub>CC</sub> Standby Current	CE = V <sub>IH</sub>		1	mA
I <sub>CC1</sub>	V <sub>CC</sub> Active Current	CE = OE = V <sub>IL</sub> f = 5 MHz		40	mA
I <sub>CC2</sub>	V <sub>CC</sub> Active Current CMOS Inputs	CE = GND, f = 5 MHz Inputs = V <sub>CC</sub> or GND, I/O = 0 mA C, E Temp Ranges		35	mA
I <sub>PP</sub>	V <sub>PP</sub> Supply Current	V <sub>PP</sub> = V <sub>CC</sub>		10	μA
V <sub>PP</sub>	V <sub>PP</sub> Read Voltage		V <sub>CC</sub> - 0.7	V <sub>CC</sub>	V
I <sub>LI</sub>	Input Load Current	V <sub>IN</sub> = 5.5V or GND	-1	1	μA
I <sub>LO</sub>	Output Leakage Current	V <sub>OUT</sub> = 5.5V or GND	-10	10	μA

### AC Electrical Characteristics

Symbol	Parameter	90		120		150		Units
		Min	Max	Min	Max	Min	Max	
t <sub>ACC</sub>	Address to Output Delay		90		120		150	ns
t <sub>CE</sub>	CE to Output Delay		90		120		150	
t <sub>OE</sub>	$\overline{OE}$ to Output Delay		40		50		50	
t <sub>DF</sub>	Output Disable to Output Float		35		25		45	
t <sub>OH</sub>	Output Hold from Addresses, CE or OE, Whichever Occurred First	0		0		0		

**Capacitance**  $T_A = +25^\circ\text{C}$ ,  $f = 1 \text{ MHz}$  (Note 2)

Symbol	Parameter	Conditions	Typ	Max	Units
$C_{IN1}$	Input Capacitance except OE/ $V_{PP}$	$V_{IN} = 0V$	6	12	pF
$C_{OUT}$	Output Capacitance	$V_{OUT} = 0V$	9	12	pF
$C_{IN2}$	OE/ $V_{PP}$ Input Capacitance	$V_{IN} = 0V$	20	25	pF

**AC Test Conditions**

Output Load                    1 TTL Gate and  $C_L = 100 \text{ pF}$  (Note 8)

Input Rise and Fall Times                     $\leq 5 \text{ ns}$

Input Pulse Levels                                0.45V to 2.4V

Timing Measurement Reference Level (Note 9)

  Inputs    0.8V and 2V

  Outputs     0.8V and 2V

**AC Waveforms** (Notes 6, 7)

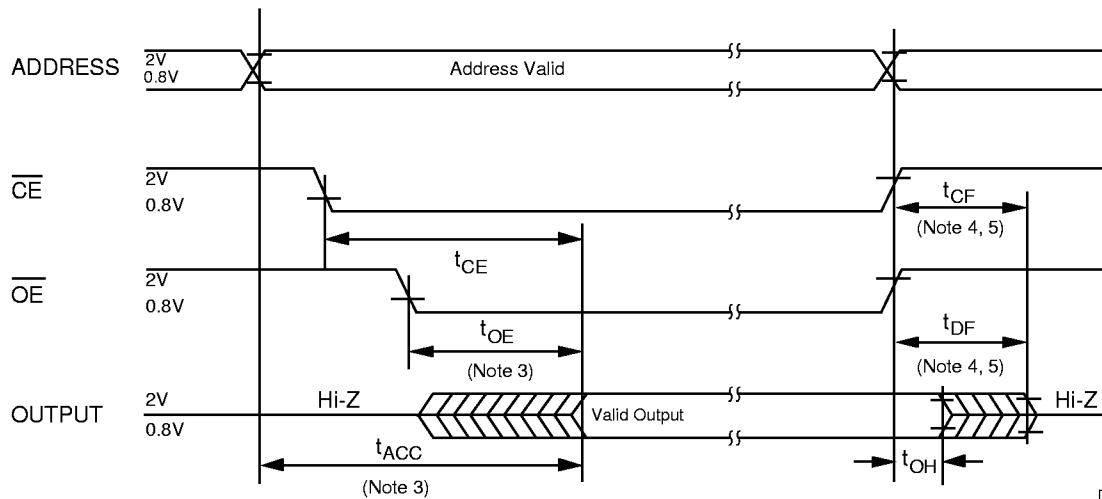

DS010834-4

**Note 1:** Stresses above those listed under "Absolute Maximum Ratings" may cause permanent damage to the device. This is a stress rating only and functional operation of the device at these or any other conditions above those indicated in the operational sections of this specification is not implied. Exposure to absolute maximum rating conditions for extended periods may affect device reliability.

**Note 2:** This parameter is only sampled and is not 100% tested.

**Note 3:**  $\overline{OE}$  may be delayed up to  $t_{ACC} - t_{OE}$  after the falling edge of  $\overline{CE}$  without impacting  $t_{ACC}$ .

**Note 4:** The  $t_{DF}$  and  $t_{CF}$  compare level is determined as follows:

High to TRI-STATE, the measured  $V_{OH}(DC) - 0.10V$ ;

Low to TRI-STATE, the measured  $V_{OL1}(DC) + 0.10V$ .

**Note 5:** TRI-STATE may be attained using  $\overline{OE}$  or  $\overline{CE}$ .

**Note 6:** The power switching characteristics of EPROMs require careful device decoupling. It is recommended that at least a 0.1  $\mu\text{F}$  ceramic capacitor be used on every device between  $V_{CC}$  and GND.

**Note 7:** The outputs must be restricted to  $V_{CC} + 1.0V$  to avoid latch-up and device damage.

**Note 8:** 1 TTL Gate:  $I_{OL} = 1.6 \text{ mA}$ ,  $I_{OH} = -400 \mu\text{A}$ .  $C_L$ : 100 pF includes fixture capacitance.

**Note 9:** Inputs and outputs can undershoot to -2.0V for 20 ns Max.

### Programming Characteristics (Note 10) and (Note 11)

Symbol	Parameter	Conditions	Min	Typ	Max	Units
$t_{AS}$	Address Setup Time		1			$\mu s$
$t_{OES}$	OE Setup Time		1			$\mu s$
$t_{DS}$	Data Setup Time		1			$\mu s$
$t_{VCS}$	$V_{CC}$ Setup Time		1			$\mu s$
$t_{AH}$	Address Hold Time		0			$\mu s$
$t_{DH}$	Data Hold Time		1			$\mu s$
$t_{CF}$	Chip Enable to Output Float Delay	$OE = V_{IL}$	0		60	ns
$t_{PW}$	Program Pulse Width		45	50	105	$\mu s$
$t_{OEH}$	OE Hold Time		1			$\mu s$
$t_{DV}$	Data Valid from CE	$OE = V_{IL}$			250	ns
$t_{PRT}$	OE Pulse Rise Time during Programming		50			ns
$t_{VR}$	$V_{PP}$ Recovery Time		1			$\mu s$
$I_{PP}$	$V_{PP}$ Supply Current during Programming Pulse	$CE = V_{IL}$ $OE = V_{PP}$			30	mA
$I_{CC}$	$V_{CC}$ Supply Current				50	mA
$T_R$	Temperature Ambient		20	25	30	$^{\circ}C$
$V_{CC}$	Power Supply Voltage		6.25	6.5	6.75	V
$V_{PP}$	Programming Supply Voltage		12.5	12.75	13	V
$t_{FR}$	Input Rise, Fall Time		5			ns
$V_{IL}$	Input Low Voltage			0	0.45	V
$V_{IH}$	Input High Voltage		2.4	4		V
$t_{IN}$	Input Timing Reference Voltage		0.8		2	V
$t_{OUT}$	Output Timing Reference Voltage		0.8		2	V

### Programming Waveforms

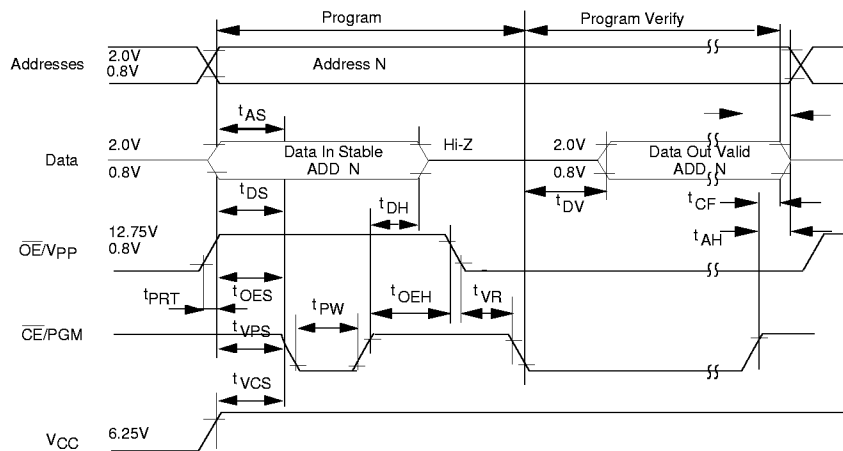

DS010834-5

**Note 10:** Fairchild's standard product warranty applies to devices programmed to specifications described herein.

**Note 11:**  $V_{CC}$  must be applied simultaneously or before  $V_{PP}$  and removed simultaneously or after  $V_{PP}$ . The EPROM must not be inserted into or removed from a board with voltage applied to  $V_{PP}$  or  $V_{CC}$ .

**Note 12:** The maximum absolute allowable voltage which may be applied to the  $V_{PP}$  pin during programming is 14V. Care must be taken when switching the  $V_{PP}$  supply to prevent any overshoot from exceeding this 14V maximum specification. At least a 0.1  $\mu F$  capacitor is required across  $V_{CC}$  to GND to suppress spurious voltage transients which may damage the device.

### Turbo Programming Algorithm Flow Chart

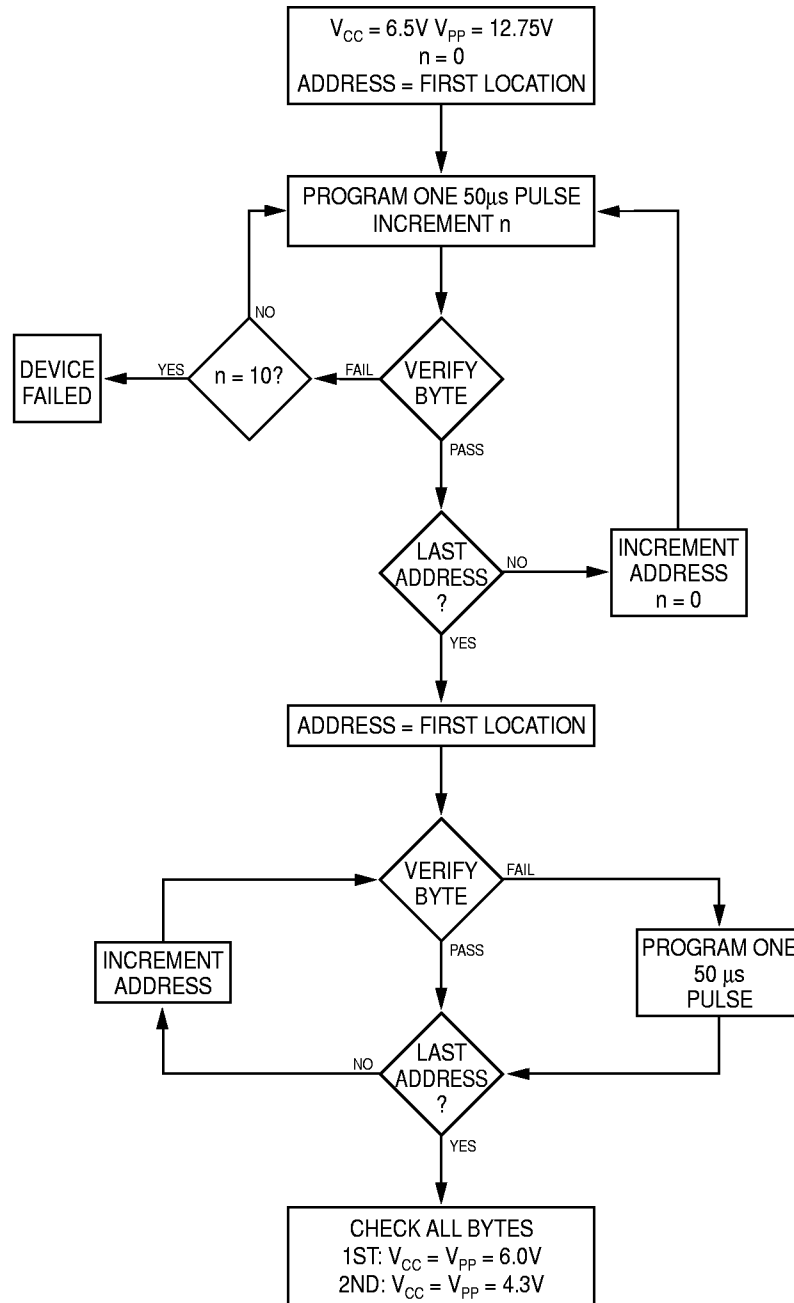

**Note:** The standard National Semiconductor algorithm may also be used but it will take longer programming time.

DS010834-6

**FIGURE 1.**

## Functional Description

### DEVICE OPERATION

The six modes of operation of the EPROM are listed in Table 1. It should be noted that all inputs for the six modes are at TTL levels. The power supplies required are  $V_{CC}$  and  $OE/V_{PP}$ . The  $OE/V_{PP}$  power supply must be at 12.75V during the three programming modes, and must be at 5V in the other three modes. The  $V_{CC}$  power supply must be at 6.5V during the three programming modes, and at 5V in the other three modes.

### Read Mode

The EPROM has two control functions, both of which must be logically active in order to obtain data at the outputs. Chip Enable ( $\overline{CE}/PGM$ ) is the power control and should be used for device selection. Output Enable ( $OE/V_{PP}$ ) is the output control and should be used to gate data to the output pins, independent of device selection. Assuming that addresses are stable, address access time ( $t_{ACC}$ ) is equal to the delay from  $\overline{CE}$  to output ( $t_{CE}$ ). Data is available at the outputs  $t_{OE}$  after the falling edge of  $OE$ , assuming that  $\overline{CE}$  has been low and addresses have been stable for at least  $t_{ACC} - t_{OE}$ .

### Standby Mode

The EPROM has a standby mode which reduces the active power dissipation by over 99%, from 220 mW to 0.55 mW. The EPROM is placed in the standby mode by applying a CMOS high signal to the  $\overline{CE}/PGM$  input. When in standby mode, the outputs are in a high impedance state, independent of the  $OE$  input.

### Output Disable

The EPROM is placed in output disable by applying a TTL high signal to the  $OE$  input. When in output disable all circuitry is enabled, except the outputs are in a high impedance state (TRISTATE).

### Output OR-Typing

Because the EPROM is usually used in larger memory arrays, Fairchild has provided a 2-line control function that accommodates this use of multiple memory connections. The 2-line control function allows for:

1. the lowest possible memory power dissipation, and
2. complete assurance that output bus contention will not occur.

To most efficiently use these two control lines, it is recommended that  $\overline{CE}/PGM$  be decoded and used as the primary device selection function, while  $OE/V_{PP}$  be made a common connection to all devices in the array and connected to the READ line from the system control bus.

This assures that all deselected memory devices are in their low power standby modes and that the output pins are active only when data is desired from a particular memory device.

### Programming

CAUTION: Exceeding 14V on pin 22 ( $\overline{OE}/V_{PP}$ ) will damage the EPROM.

Initially, and after each erasure, all bits of the EPROM are in the "1's" state. Data is introduced by selectively programming "0's" into the desired bit locations. Although only "0's" will be programmed, both "1's" and "0's" can be presented in the data word. The only way to change a "0" to a "1" is by ultraviolet light erasure.

The EPROM is in the programming mode when the  $\overline{OE}/V_{PP}$  is at 12.75V. It is required that at least a 0.1  $\mu F$  capacitor be placed across  $V_{CC}$  to ground to suppress spurious voltage transients which may damage the device. The data to be programmed is applied 8 bits in parallel to the data output pins. The levels required for the address and data inputs are TTL.

When the address and data are stable, an active low, TTL program pulse is applied to the  $\overline{CE}/PGM$  input. A program pulse must be applied at each address location to be programmed.

The EPROM is programmed with the Turbo Programming Algorithm shown in Figure 1. Each Address is programmed with a series of 50  $\mu s$  pulses until it verifies good, up to a maximum of 10 pulses. Most memory cells will program with a single 50  $\mu s$  pulse. (The standard National Semiconductor Algorithm may also be used but it will have longer programming time.)

The EPROM must not be programmed with a DC signal applied to the  $\overline{CE}/PGM$  input.

Programming multiple EPROM in parallel with the same data can be easily accomplished due to the simplicity of the programming requirements. Like inputs of the parallel EPROM may be connected together when they are programmed with the same data. A low level TTL pulse applied to the  $\overline{CE}/PGM$  input programs the paralleled EPROM.

### Program Inhibit

Programming multiple EPROMs in parallel with different data is also easily accomplished. Except for  $\overline{CE}/PGM$  all like inputs (including  $OE/V_{PP}$ ) of the parallel EPROMs may be common. A TTL low level program pulse applied to an EPROM's  $\overline{CE}/PGM$  input with  $OE/V_{PP}$  at 12.75V will program that EPROM. A TTL high level  $\overline{CE}/PGM$  input inhibits the other EPROMs from being programmed.

### Program Verify

A verify should be performed on the programmed bits to determine whether they were correctly programmed. The verify is accomplished with  $OE/V_{PP}$  and  $\overline{CE}$  at  $V_{IL}$ . Data should be verified  $T_{DV}$  after the falling edge of  $\overline{CE}$ .

### AFTER PROGRAMMING

Opaque labels should be placed over the EPROM window to prevent unintentional erasure. Covering the window will also prevent temporary functional failure due to the generation of photo currents.

### MANUFACTURER'S IDENTIFICATION CODE

The EPROM has a manufacturer's identification code to aid in programming. When the device is inserted in an EPROM programmer socket, the programmer reads the code and then automatically calls up the specific programming algorithm for the part. This automatic programming control is only possible with programmers which have the capability of reading the code.

The Manufacturer's Identification code, shown in Table 2, specifically identifies the manufacturer and device type. The code for NM27C512 is "8F85", where "8F" designates that it is made by Fairchild Semiconductor, and "85" designates a 512K part.

The code is accessed by applying 12V  $\pm 0.5V$  to address pin A9. Addresses A1-A8, A10-A16, and all control pins

## Functional Description (Continued)

are held at  $V_{IL}$ . Address pin A0 is held at  $V_{IL}$  for the manufacturer's code, and held at  $V_{IH}$  for the device code. The code is read on the eight data pins, O0–O7. Proper code access is only guaranteed at  $25^{\circ}\text{C} \pm 5^{\circ}\text{C}$ .

### ERASURE CHARACTERISTICS

The erasure characteristics of the device are such that erasure begins to occur when exposed to light with wavelengths shorter than approximately 4000 Angstroms ( $\text{\AA}$ ). It should be noted that sunlight and certain types of fluorescent lamps have wavelengths in the 3000 $\text{\AA}$ –4000 $\text{\AA}$  range.

The recommended erasure procedure for the EPROM is exposure to short wave ultraviolet light which has a wavelength of 2537 $\text{\AA}$ . The integrated dose (i.e., UV intensity x exposure time) for erasure should be minimum of 15W-sec/cm<sup>2</sup>.

The EPROM should be placed within 1 inch of the lamp tubes during erasure. Some lamps have a filter on their tubes which should be removed before erasure.

An erasure system should be calibrated periodically. The distance from lamp to device should be maintained at one inch. The erasure time increases as the square of the distance from the lamp (if distance is doubled the erasure time increases by factor of 4).

### Mode Selection

The modes of operation of the NM27C512 are listed in Table 1. A single 5V power supply is required in the read mode. All inputs are TTL levels excepts for  $V_{PP}$  and A9 for device signature.

**TABLE 1. Mode Selection**

Mode	Pins	$\overline{\text{CE}}/\text{PGM}$	$\overline{\text{OE}}/V_{PP}$	$V_{CC}$	Outputs
Read		$V_{IL}$	$V_{IL}$	5.0V	$D_{OUT}$
Output Disable		X (Note 13)	$V_{IH}$	5.0V	High Z
Standby		$V_{IH}$	X	5.0V	High Z
Programming		$V_{IL}$	12.75V	6.25V	$D_{IN}$
Program Verify		$V_{IL}$	$V_{IL}$	6.25V	$D_{OUT}$
Program Inhibit		$V_{IH}$	12.75V	6.25V	High Z

**Note 13:** X can be  $V_{IL}$  or  $V_{IH}$ .

**TABLE 2. Manufacturer's Identification Code**

Pins	A0 (10)	A9 (24)	07 (19)	06 (18)	05 (17)	04 (16)	03 (15)	02 (13)	01 (12)	00 (11)	Hex Data
Manufacturer Code	$V_{IL}$	12V	1	0	0	0	1	1	1	1	8F
Device Code	$V_{IH}$	12V	1	0	0	0	0	1	0	1	85

Lamps lose intensity as they age. When a lamp is changed, the distance has changed, or the lamp has aged, the system should be checked to make certain full erasure is occurring. Incomplete erasure will cause symptoms that can be misleading. Programmers, components, and even system designs have been erroneously suspected when incomplete erasure was the problem.

### SYSTEM CONSIDERATION

The power switching characteristics of EPROMs require careful decoupling of the devices. The supply current,  $I_{CC}$ , has three segments that are of interest to the system designer: the standby current level, the active current level, and the transient current peaks that are produced by voltage transitions on input pins. The magnitude of these transient current peaks is dependent on the output capacitance loading of the device. The associated  $V_{CC}$  transient voltage peaks can be suppressed by properly selected decoupling capacitors. It is recommended that at least a 0.1  $\mu\text{F}$  ceramic capacitor be used on every device between  $V_{CC}$  and GND. This should be a high frequency capacitor of low inherent inductance. In addition, at least a 4.7  $\mu\text{F}$  bulk electrolytic capacitor should be used between  $V_{CC}$  and GND for each eight devices. The bulk capacitor should be located near where the power supply is connected to the array. The purpose of the bulk capacitor is to overcome the voltage drop caused by the inductive effects of the PC board traces.

**Physical Dimensions** inches (millimeters) unless otherwise noted

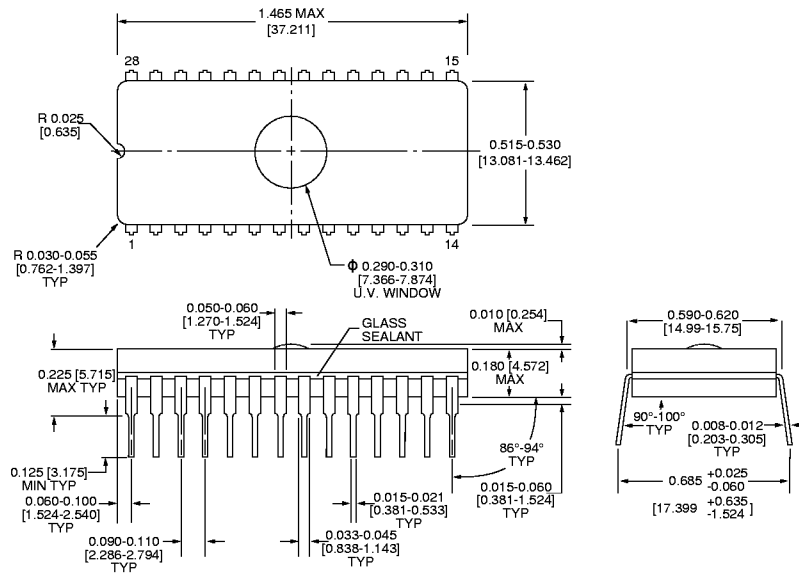

**UV Window Cavity Dual-In-Line Cerdip Package (JQ)**  
**Order Number NM27C512Q**  
**Package Number J28CQ**

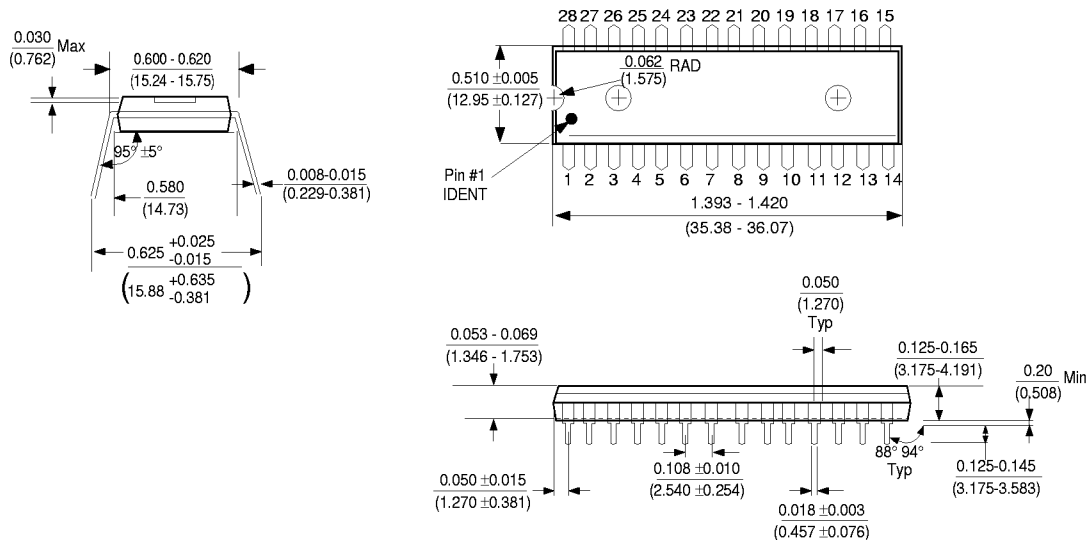

**28-Lead Plastic One-Time-Programmable Dual-In-Line**  
**Order Number NM27C512N**  
**Package Number N28B**

**Physical Dimensions inches (millimeters) unless otherwise noted**

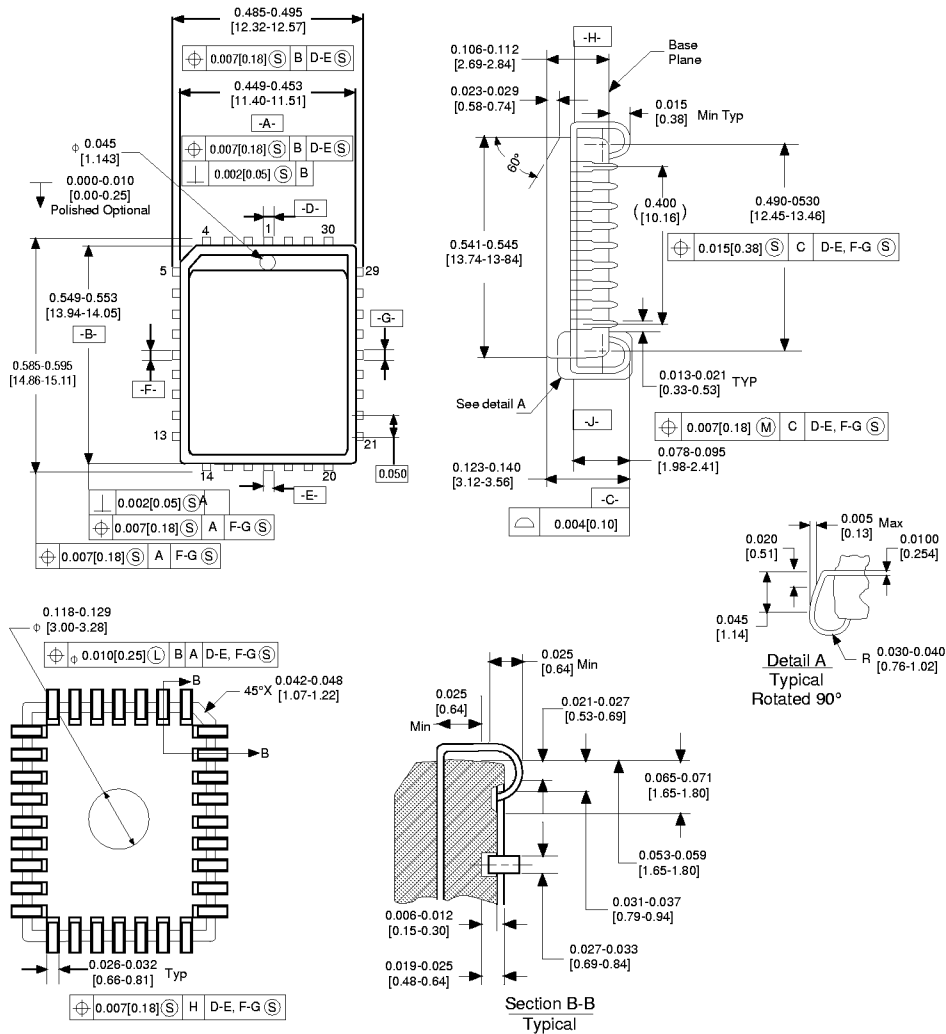

**32-Lead Plastic Leaded Chip Carrier (PLCC)  
Order Number NM27C512V  
Package Number VA32A**

**Life Support Policy**

Fairchild's products are not authorized for use as critical components in life support devices or systems without the express written approval of the President of Fairchild Semiconductor Corporation. As used herein:

1. Life support devices or systems are devices or systems which, (a) are intended for surgical implant into the body, or (b) support or sustain life, and whose failure to perform, when properly used in accordance with instructions for use provided in the labeling, can be reasonably expected to result in a significant injury to the user.
2. A critical component is any component of a life support device or system whose failure to perform can be reasonably expected to cause the failure of the life support device or system, or to affect its safety or effectiveness.

**Fairchild Semiconductor Americas**  
Customer Response Center  
Tel: 1-888-522-5372

**Fairchild Semiconductor Europe**  
Deutsch Tel: +44 (0) 1793-856858  
English Tel: +49 (0) 8141-6102-0  
Français Tel: +44 (0) 1793-856856  
Italiano Tel: +33 (0) 1-6930-3696  
Tel: +39 (0) 2-24911-1

**Fairchild Semiconductor Hong Kong**  
8/F, Room 808, Empire Centre  
68 Mody Road, Tsimshatsui East  
Kowloon, Hong Kong  
Tel: +852-2722-8338  
Fax: +852-2722-8383

**Fairchild Semiconductor Japan Ltd.**  
4F, Natsume Bldg.  
2-18-6, Yushima, Bunkyo-ku  
Tokyo, 113-0034 Japan  
Tel: 81-3-3818-8840  
Fax: 81-3-3818-8841

## Looking for pricing, stock, or lifecycle information?

Click below to explore more details on WIN SOURCE:

- ⊖ [View NM27C512V120 on WIN SOURCE](#)
- ⊖ [Fairchild/ON Semiconductor Information](#)

## Optimize Your Supply Chain with WIN SOURCE Solutions

- ✓ Global Sourcing Solution
- ✓ Obsolete Management
- ✓ Cost Control Management
- ✓ Shortage Management
- ✓ Alternative Solution
- ✓ Excess Inventory Management