



**THE DATASHEET OF
ADS1014IDGST**



ADS101x Ultra-Small, Low-Power, I²C-Compatible, 3.3-kSPS, 12-Bit ADCs With Internal Reference, Oscillator, and Programmable Comparator

1 Features

- Ultra-Small X2QFN Package:
2 mm × 1.5 mm × 0.4 mm
- 12-Bit Noise-Free Resolution
- Wide Supply Range: 2.0 V to 5.5 V
- Low Current Consumption: 150 μ A
(Continuous-Conversion Mode)
- Programmable Data Rate:
128 SPS to 3.3 kSPS
- Single-Cycle Settling
- Internal Low-Drift Voltage Reference
- Internal Oscillator
- I²C Interface: Four Pin-Selectable Addresses
- Four Single-Ended or Two Differential Inputs
(ADS1015)
- Programmable Comparator (ADS1014 and
ADS1015)
- Operating Temperature Range:
–40°C to +125°C

2 Applications

- Portable Instrumentation
- Battery Voltage and Current Monitoring
- Temperature Measurement Systems
- Consumer Electronics
- Factory Automation and Process Control

3 Description

The ADS1013, ADS1014, and ADS1015 devices (ADS101x) are precision, low-power, 12-bit, I²C-compatible, analog-to-digital converters (ADCs) offered in an ultra-small, leadless, X2QFN-10 package, and a VSSOP-10 package. The ADS101x devices incorporate a low-drift voltage reference and an oscillator. The ADS1014 and ADS1015 also incorporate a programmable gain amplifier (PGA) and a digital comparator. These features, along with a wide operating supply range, make the ADS101x well suited for power- and space-constrained, sensor measurement applications.

The ADS101x perform conversions at data rates up to 3300 samples per second (SPS). The PGA offers input ranges from ± 256 mV to ± 6.144 V, allowing precise large- and small-signal measurements. The ADS1015 features an input multiplexer (MUX) that allows two differential or four single-ended input measurements. Use the digital comparator in the ADS1014 and ADS1015 for under- and overvoltage detection.

The ADS101x operate in either continuous-conversion mode or single-shot mode. The devices are automatically powered down after one conversion in single-shot mode; therefore, power consumption is significantly reduced during idle periods.

Device Information⁽¹⁾

PART NUMBER	PACKAGE	BODY SIZE (NOM)
ADS101x	X2QFN (10)	1.50 mm × 2.00 mm
	VSSOP (10)	3.00 mm × 3.00 mm

(1) For all available packages, see the package option addendum at the end of the data sheet.

Simplified Block Diagrams

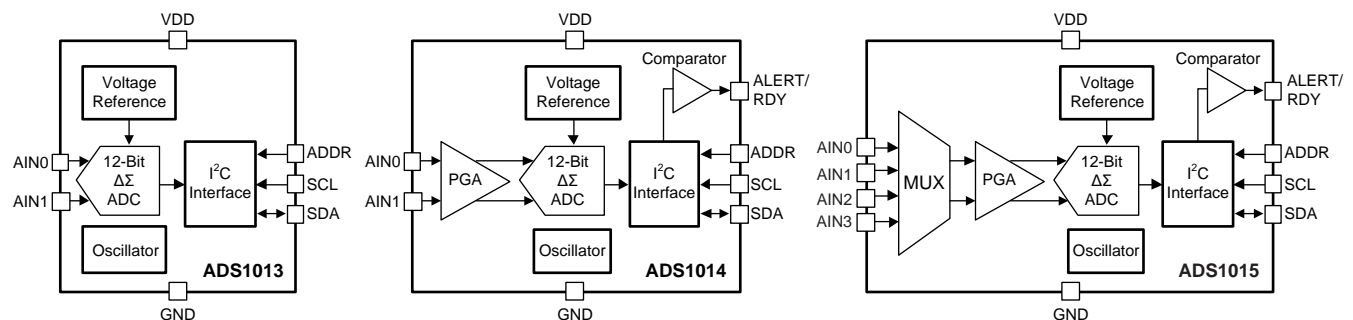

Copyright © 2016, Texas Instruments Incorporated



• Changed <i>Digital input voltage</i> max value from 5.5 V to VDD + 0.3 V in <i>Absolute Maximum Ratings</i> table	5
• Deleted <i>Analog input current</i> rows in <i>Absolute Maximum Ratings</i> table.....	5
• Added <i>Input current</i> row in <i>Absolute Maximum Ratings</i> table	5
• Added <i>Operating temperature</i> range of –40°C to +125°C back into <i>Absolute Maximum Ratings</i> table	5
• Added minimum specification of –40°C for T _J in <i>Absolute Maximum Ratings</i> table	5
• Changed <i>Electrical Characteristics</i> table conditions line for clarity	6
• Changed all instances of "FS" to "FSR"	6
• Deleted FSR from <i>Electrical Characteristics</i> and moved to <i>Recommended Operating Conditions</i> table	6
• Added values from Table 2 to <i>Differential input impedance</i> parameter in <i>Electrical Characteristics</i>	6
• Deleted <i>Output noise</i> parameter from <i>Electrical Characteristics</i>	6
• Changed <i>Offset error</i> empty min value to –0.5, and max value from ±0.5 to 0.5 for clarity in <i>Electrical Characteristics</i> table	6
• Changed V _{IH} parameter max value from 5.5 V to VDD in <i>Electrical Characteristics</i> table	6
• Changed V _{IL} parameter min value from GND – 0.5 V to GND in <i>Electrical Characteristics</i> table	6
• Changed <i>Input leakage current</i> parameters from two rows to one row, changed test conditions from V _{IH} = 5.5V and V _{IL} = GND to GND < V _{DIG} < VDD, and changed min value from 10 µA to –10 µA in <i>Electrical Characteristics</i> table.....	6
• Deleted <i>Power-supply voltage</i> parameter from <i>Electrical Characteristics</i> and moved to <i>Recommended Operating Conditions</i> table.....	6
• Deleted <i>Specified temperature</i> parameter from <i>Electrical Characteristics</i> and moved to <i>Recommended Operating Conditions</i> table.....	6
• Deleted <i>Storage temperature</i> parameter from <i>Electrical Characteristics</i> to <i>Absolute Maximum Ratings</i> table	6
• Deleted <i>Operating temperature</i> parameter from <i>Temperature</i> section of <i>Electrical Characteristics</i> table.....	6
• Changed text in note 1 of <i>Electrical Characteristics</i> table from "In no event should more than VDD + 0.3 V be applied to this device" to "No more than VDD + 0.3 V must be applied to the analog inputs of the device. See Table 1 for more information."	6
• Added condition statement in <i>Timing Requirements: P_C</i>	7
• Added note 1 to <i>Timing Requirements</i> table	7
• Deleted Figure 7, <i>Noise Plot</i>	8
• Changed Figure 8; deleted "Gain = 2/3, 1, 2, 4, 8, or 16" from figure	9
• Added <i>Functional Block Diagrams</i> for ADS1014 and ADS1013	9
• Changed <i>Analog Inputs</i> section to provide LSB size information instead of PGA setting	11
• Changed <i>Full-Scale Input</i> section title to <i>Full-Scale Range (FSR) and LSB Size</i> , and updated section for clarity	12
• Added <i>Voltage Reference</i> and <i>Oscillator</i> sections	12
• Changed <i>Comparator</i> section title to <i>Digital Comparator</i> , and updated section for clarity.	12
• Changed <i>Conversion Ready Pin</i> section for clarity	14
• Changed <i>Register Map</i> section for clarity	22
• Changed <i>Application Information</i> section for clarity	26
• Added <i>Input Protection</i> section.....	27
• Added <i>Unused Inputs and Outputs</i> section.....	27
• Changed <i>Aliasing</i> section title to <i>Analog Input Filtering</i> and updated section for clarity.....	28
• Added <i>Typical Application</i> section.....	31

Changes from Revision B (September 2009) to Revision C
Page

• Deleted operating temperature bullet from <i>Features</i> section	1
• Deleted <i>Operating temperature</i> range parameter from <i>Absolute Maximum Ratings</i> table	5
• Deleted <i>Operating temperature</i> parameter from <i>Temperature</i> subsection of <i>Electrical Characteristics</i> table.....	6
• Changed Figure 2 to reflect maximum operating temperature.....	8

ADS1013, ADS1014, ADS1015

SBAS473E –MAY 2009–REVISED JANUARY 2018

www.ti.com

-
- Changed Figure 3 to reflect maximum operating temperature..... 8
 - Changed Figure 4 to reflect maximum operating temperature..... 8
 - Changed Figure 5 to reflect maximum operating temperature..... 8
 - Changed Figure 6 to reflect maximum operating temperature..... 8
-

5 Device Comparison Table

DEVICE	RESOLUTION (Bits)	MAXIMUM SAMPLE RATE (SPS)	INPUT CHANNELS Differential (Single-Ended)	PGA	INTERFACE	SPECIAL FEATURES
ADS1015	12	3300	2 (4)	Yes	I ² C	Comparator
ADS1014	12	3300	1 (1)	Yes	I ² C	Comparator
ADS1013	12	3300	1 (1)	No	I ² C	None
ADS1115	16	860	2 (4)	Yes	I ² C	Comparator
ADS1114	16	860	1 (1)	Yes	I ² C	Comparator
ADS1113	16	860	1(1)	No	I ² C	None
ADS1018	12	3300	2 (4)	Yes	SPI	Temperature sensor
ADS1118	16	860	2 (4)	Yes	SPI	Temperature sensor

6 Pin Configuration and Functions

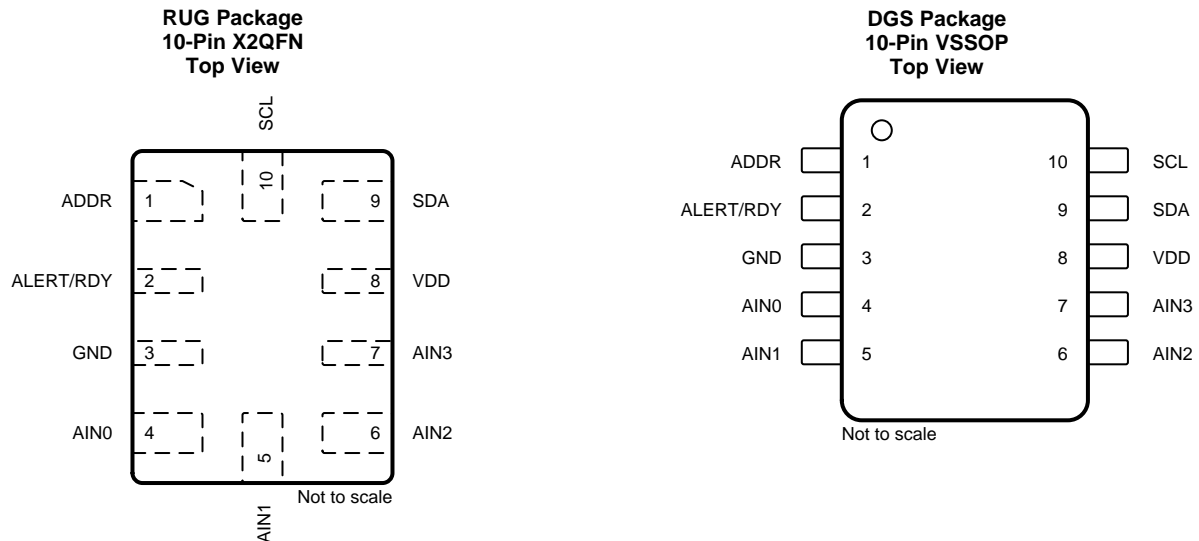

Pin Functions

NAME	PIN ⁽¹⁾			TYPE	DESCRIPTION
	ADS1013	ADS1014	ADS1015		
ADDR	1	1	1	Digital input	I ² C slave address select
AIN0	4	4	4	Analog input	Analog input 0
AIN1	5	5	5	Analog input	Analog input 1
AIN2	—	—	6	Analog input	Analog input 2 (ADS1015 only)
AIN3	—	—	7	Analog input	Analog input 3 (ADS1015 only)
ALERT/RDY	—	2	2	Digital output	Comparator output or conversion ready (ADS1014 and ADS1015 only)
GND	3	3	3	Analog	Ground
NC	2, 6, 7	6, 7	—	—	Not connected
SCL	10	10	10	Digital input	Serial clock input. Clocks data on SDA
SDA	9	9	9	Digital I/O	Serial data. Transmits and receives data
VDD	8	8	8	Analog	Power supply. Connect a 0.1-μF, power-supply decoupling capacitor to GND.

(1) See the [Unused Inputs and Outputs](#) section for unused pin connections.

7 Specifications

7.1 Absolute Maximum Ratings

over operating free-air temperature range (unless otherwise noted)⁽¹⁾

		MIN	MAX	UNIT
Power-supply voltage	VDD to GND	-0.3	7	V
Analog input voltage	AIN0, AIN1, AIN2, AIN3	GND - 0.3	VDD + 0.3	V
Digital input voltage	SDA, SCL, ADDR, ALERT/RDY	GND - 0.3	5.5	V
Input current, continuous	Any pin except power supply pins	-10	10	mA
Temperature	Operating ambient, T _A	-40	125	°C
	Junction, T _J	-40	150	
	Storage, T _{stg}	-60	150	

- (1) Stresses beyond those listed under *Absolute Maximum Ratings* may cause permanent damage to the device. These are stress ratings only, which do not imply functional operation of the device at these or any other conditions beyond those indicated under *Recommended Operating Conditions*. Exposure to absolute-maximum-rated conditions for extended periods may affect device reliability.

7.2 ESD Ratings

		VALUE	UNIT
V _(ESD) Electrostatic discharge	Human-body model (HBM), per ANSI/ESDA/JEDEC JS-001 ⁽¹⁾	±2000	V
	Charged-device model (CDM), per JEDEC specification JESD22-C101 ⁽²⁾	±500	

- (1) JEDEC document JEP155 states that 500-V HBM allows safe manufacturing with a standard ESD control process.
 (2) JEDEC document JEP157 states that 250-V CDM allows safe manufacturing with a standard ESD control process.

7.3 Recommended Operating Conditions

		MIN	NOM	MAX	UNIT
POWER SUPPLY					
Power supply (VDD to GND)		2		5.5	V
ANALOG INPUTS⁽¹⁾					
FSR	Full-scale input voltage range ⁽²⁾ (V _{IN} = V _(AINP) - V _(AINN))	±0.256		±6.144	V
V _(AINx)	Absolute input voltage	GND		VDD	V
DIGITAL INPUTS					
V _{DIG}	Digital input voltage	GND		5.5	V
TEMPERATURE					
T _A	Operating ambient temperature	-40		125	°C

- (1) AINP and AINN denote the selected positive and negative inputs. AINx denotes one of the four available analog inputs.
 (2) This parameter expresses the full-scale range of the ADC scaling. No more than VDD + 0.3 V must be applied to the analog inputs of the device. See [Table 1](#) more information.

7.4 Thermal Information

THERMAL METRIC ⁽¹⁾	ADS101x		UNIT	
	DGS (VSSOP)	RUG (X2QFN)		
	10 PINS	10 PINS		
R _{θJA}	Junction-to-ambient thermal resistance	182.7	245.2	°C/W
R _{θJC(top)}	Junction-to-case (top) thermal resistance	67.2	69.3	°C/W
R _{θJB}	Junction-to-board thermal resistance	103.8	172.0	°C/W
ψ _{JT}	Junction-to-top characterization parameter	10.2	8.2	°C/W
ψ _{JB}	Junction-to-board characterization parameter	102.1	170.8	°C/W
R _{θJC(bot)}	Junction-to-case (bottom) thermal resistance	N/A	N/A	°C/W

- (1) For more information about traditional and new thermal metrics, see the [Semiconductor and IC Package Thermal Metrics](#) application report.

7.5 Electrical Characteristics

At VDD = 3.3 V, data rate = 128 SPS, and full-scale input-voltage range (FSR) = ±2.048 V (unless otherwise noted). Maximum and minimum specifications apply from TA = –40°C to +125°C. Typical specifications are at TA = 25°C.

PARAMETER		TEST CONDITIONS	MIN	TYP	MAX	UNIT
ANALOG INPUT						
Common-mode input impedance	FSR = ±6.144 V ⁽¹⁾		10		MΩ	
	FSR = ±4.096 V ⁽¹⁾ , FSR = ±2.048 V		6			
	FSR = ±1.024 V		3			
	FSR = ±0.512 V, FSR = ±0.256 V		100			
Differential input impedance	FSR = ±6.144 V ⁽¹⁾		22		MΩ	
	FSR = ±4.096 V ⁽¹⁾		15			
	FSR = ±2.048 V		4.9			
	FSR = ±1.024 V		2.4			
		FSR = ±0.512 V, ±0.256 V	710		kΩ	
SYSTEM PERFORMANCE						
Resolution (no missing codes)		12		Bits		
DR	Data rate	128, 250, 490, 920, 1600, 2400, 3300		SPS		
Data rate variation		All data rates	–10%	10%		
INL	Integral nonlinearity	DR = 128 SPS, FSR = ±2.048 V ⁽²⁾	0.5		LSB	
Offset error	FSR = ±2.048 V, differential inputs		–0.5	0	0.5	LSB
	FSR = ±2.048 V, single-ended inputs		±0.25			
Offset drift over temperature		FSR = ±2.048 V	0.005		LSB/°C	
Long-term offset drift		FSR = ±2.048 V, TA = 125°C, 1000 hrs	±1		LSB	
Offset channel match		Match between any two inputs	0.25		LSB	
Gain error ⁽³⁾		FSR = ±2.048 V, TA = 25°C	0.05%		0.25%	
Gain drift over temperature ⁽³⁾	FSR = ±0.256 V		7		ppm/°C	
	FSR = ±2.048 V		5			
	FSR = ±6.144 V ⁽¹⁾		5			
Long-term gain drift		FSR = ±2.048 V, TA = 125°C, 1000 hrs	±0.05		%	
Gain match ⁽³⁾		Match between any two gains	0.02%		0.1%	
Gain channel match		Match between any two inputs	0.05%		0.1%	
DIGITAL INPUT/OUTPUT						
V _{IH}	High-level input voltage	0.7 VDD		VDD		V
V _{IL}	Low-level input voltage	GND		0.3 VDD		V
V _{OL}	Low-level output voltage	I _{OL} = 3 mA	GND	0.15	0.4	V
Input leakage current		GND < V _{DIG} < VDD	–10	10		μA
POWER-SUPPLY						
I _{VDD}	Supply current	Power-down	TA = 25°C	0.5	2	μA
					5	
	Operating	TA = 25°C	150	200		
				300		
P _D	VDD = 5.0 V		0.9		mW	
	VDD = 3.3 V		0.5			
	VDD = 2.0 V		0.3			

(1) This parameter expresses the full-scale range of the ADC scaling. No more than VDD + 0.3 V must be applied to the analog inputs of the device. See [Table 1](#) more information.

(2) Best-fit INL; covers 99% of full-scale.

(3) Includes all errors from onboard PGA and voltage reference.

7.6 Timing Requirements: I²C

over operating ambient temperature range and VDD = 2.0 V to 5.5 V (unless otherwise noted)

		FAST MODE		HIGH-SPEED MODE		UNIT
		MIN	MAX	MIN	MAX	
f_{SCL}	SCL Clock Frequency	0.01	0.4	0.01	3.4	MHz
t_{BUF}	Bus free time between START and STOP condition	600		160		ns
t_{HDSTA}	Hold time after repeated START condition. After this period, the first clock is generated.	600		160		ns
t_{SUSTA}	Setup time for a repeated START condition	600		160		ns
t_{SUSTO}	Setup time for STOP condition	600		160		ns
t_{HDDAT}	Data hold time	0		0		ns
t_{SUDAT}	Data setup time	100		10		ns
t_{LOW}	Low period of the SCL clock pin	1300		160		ns
t_{HIGH}	High period for the SCL clock pin	600		60		ns
t_F	Rise time for both SDA and SCL signals ⁽¹⁾		300		160	ns
t_R	Fall time for both SDA and SCL signals ⁽¹⁾		300		160	ns

(1) For high-speed mode maximum values, the capacitive load on the bus line must not exceed 400 pF.

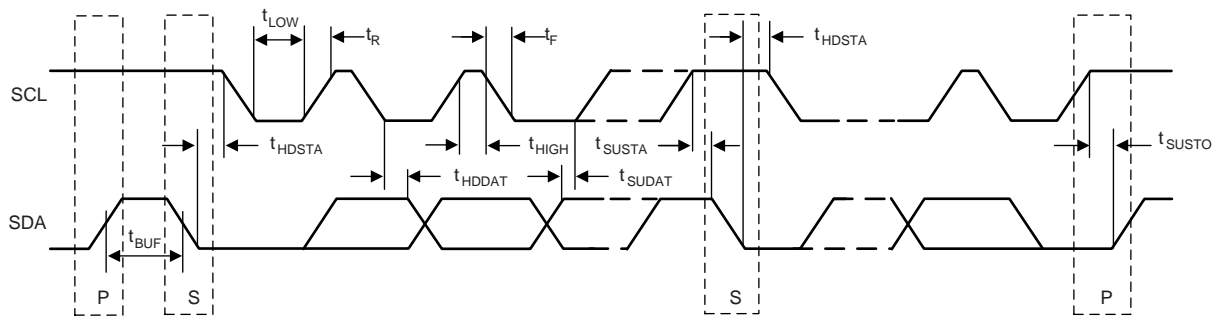

Figure 1. I²C Interface Timing

7.7 Typical Characteristics

at $T_A = 25^\circ\text{C}$, $V_{DD} = 3.3\text{ V}$, $\text{FSR} = \pm 2.048\text{ V}$, $\text{DR} = 128\text{ SPS}$ (unless otherwise noted)

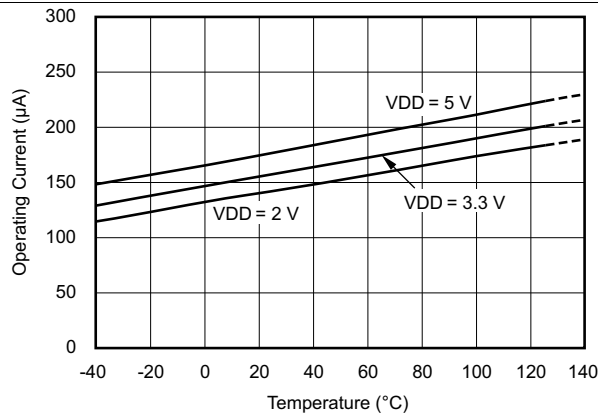

Figure 2. Operating Current vs Temperature

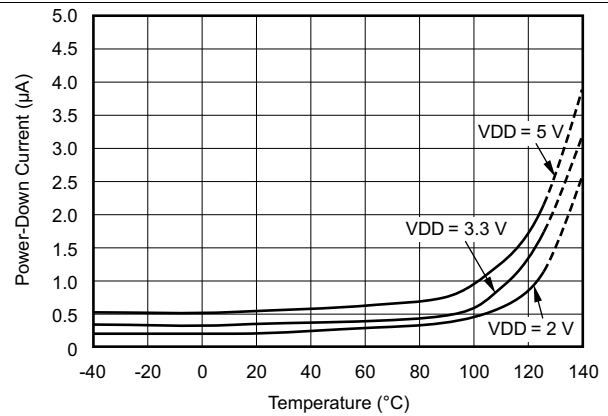

Figure 3. Power-Down Current vs Temperature

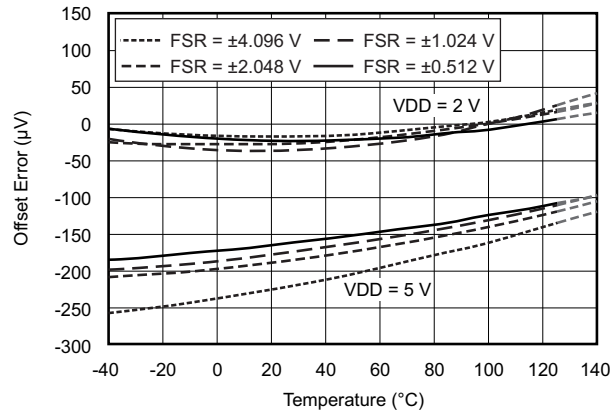

Figure 4. Single-Ended Offset Error vs Temperature

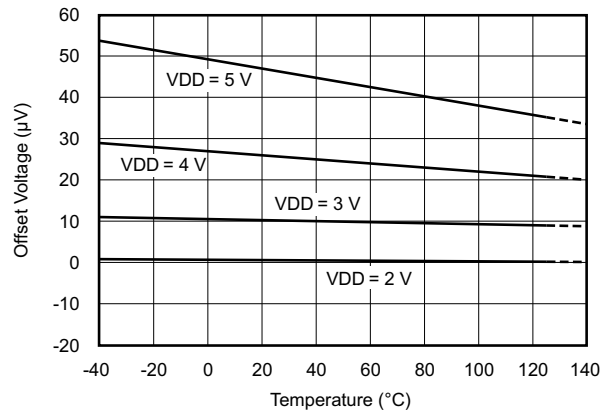

Figure 5. Differential Offset vs Temperature

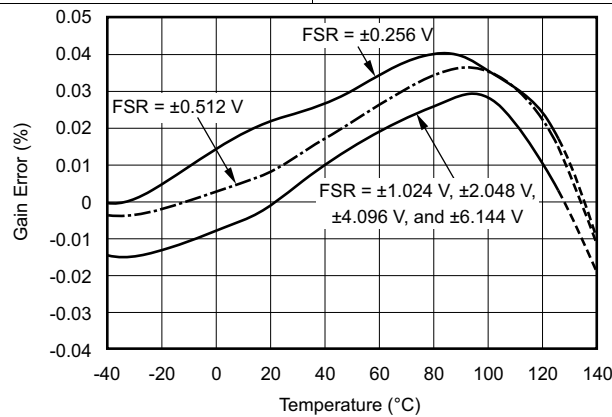

Figure 6. Gain Error vs Temperature

8 Detailed Description

8.1 Overview

The ADS101x are very small, low-power, noise-free, 12-bit, delta-sigma ($\Delta\Sigma$) analog-to-digital converters (ADCs). The ADS101x consist of a $\Delta\Sigma$ ADC core with an internal voltage reference, a clock oscillator and an I²C interface. The ADS1014 and ADS1015 also integrate a programmable gain amplifier (PGA) and a programmable digital comparator. Figure 7, Figure 8, and Figure 9 show the functional block diagrams of ADS1015, ADS1014, and ADS1013, respectively.

The ADS101x ADC core measures a differential signal, V_{IN} , that is the difference of $V_{(AINP)}$ and $V_{(AINN)}$. The converter core consists of a differential, switched-capacitor $\Delta\Sigma$ modulator followed by a digital filter. This architecture results in a very strong attenuation of any common-mode signals. Input signals are compared to the internal voltage reference. The digital filter receives a high-speed bitstream from the modulator and outputs a code proportional to the input voltage.

The ADS101x have two available conversion modes: single-shot and continuous-conversion. In single-shot mode, the ADC performs one conversion of the input signal upon request, stores the conversion value to an internal conversion register, and then enters a power-down state. This mode is intended to provide significant power savings in systems that only require periodic conversions or when there are long idle periods between conversions. In continuous-conversion mode, the ADC automatically begins a conversion of the input signal as soon as the previous conversion is completed. The rate of continuous conversion is equal to the programmed data rate. Data can be read at any time and always reflect the most recent completed conversion.

8.2 Functional Block Diagrams

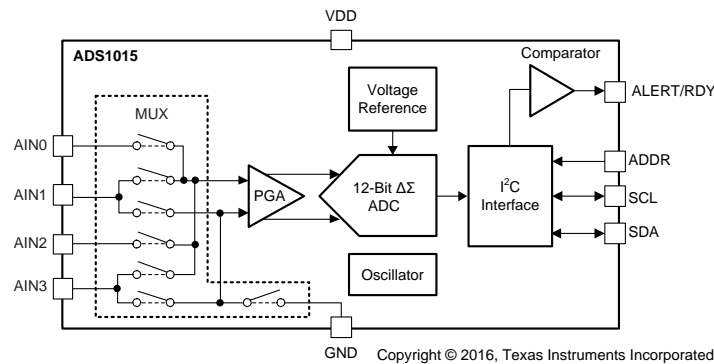

Figure 7. ADS1015 Block Diagram

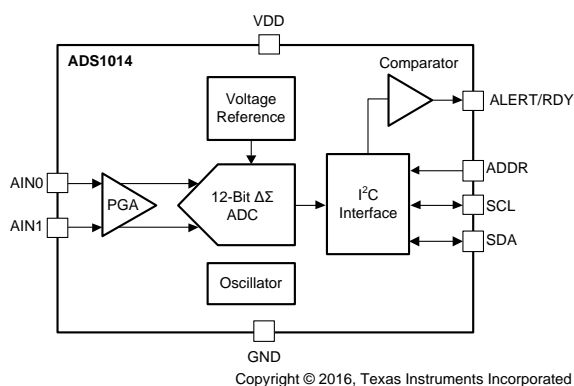

Figure 8. ADS1014 Block Diagram

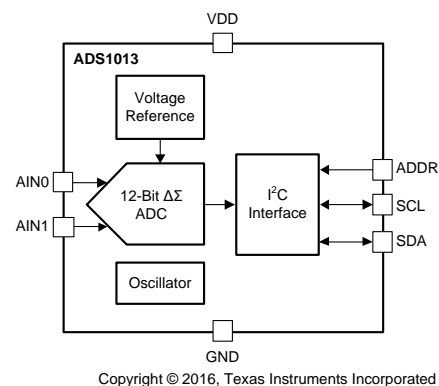
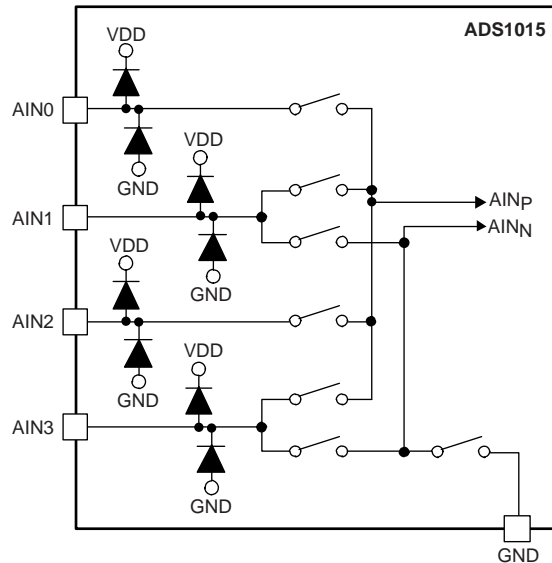

Figure 9. ADS1013 Block Diagram

8.3 Feature Description

8.3.1 Multiplexer

The ADS1015 contains an input multiplexer (MUX), as shown in Figure 10. Either four single-ended or two differential signals can be measured. Additionally, AIN0 and AIN1 may be measured differentially to AIN3. The multiplexer is configured by bits MUX[2:0] in the Config register. When single-ended signals are measured, the negative input of the ADC is internally connected to GND by a switch within the multiplexer.



Copyright © 2016, Texas Instruments Incorporated

Figure 10. Input Multiplexer

The ADS1013 and ADS1014 do not have an input multiplexer and can measure either one differential signal or one single-ended signal. For single-ended measurements, connect the AIN1 pin to GND externally. In subsequent sections of this data sheet, AIN_P refers to AIN0 and AIN_N refers to AIN1 for the ADS1013 and ADS1014.

Electrostatic discharge (ESD) diodes connected to VDD and GND protect the ADS101x analog inputs. Keep the absolute voltage of any input within the range shown in Equation 1 to prevent the ESD diodes from turning on.

$$\text{GND} - 0.3 \text{ V} < V_{(\text{AINX})} < \text{VDD} + 0.3 \text{ V} \quad (1)$$

If the voltages on the input pins can potentially violate these conditions, use external Schottky diodes and series resistors to limit the input current to safe values (see the *Absolute Maximum Ratings* table).

Feature Description (continued)

8.3.2 Analog Inputs

The ADS101x use a switched-capacitor input stage where capacitors are continuously charged and then discharged to measure the voltage between A_{INP} and A_{INN} . The frequency at which the input signal is sampled is called the sampling frequency or the modulator frequency (f_{MOD}). The ADS101x has a 1-MHz internal oscillator that is further divided by a factor of 4 to generate f_{MOD} at 250 kHz. The capacitors used in this input stage are small, and to external circuitry, the average loading appears resistive. Figure 11 shows this structure. The capacitor values set the resistance and switching rate. Figure 12 shows the timing for the switches in Figure 11. During the sampling phase, switches S_1 are closed. This event charges C_{A1} to $V_{(A_{INP})}$, C_{A2} to $V_{(A_{INN})}$, and C_B to $(V_{(A_{INP})} - V_{(A_{INN})})$. During the discharge phase, S_1 is first opened and then S_2 is closed. Both C_{A1} and C_{A2} then discharge to approximately 0.7 V and C_B discharges to 0 V. This charging draws a very small transient current from the source driving the ADS101x analog inputs. The average value of this current can be used to calculate the effective impedance (Z_{eff}), where $Z_{eff} = V_{IN} / I_{AVERAGE}$.

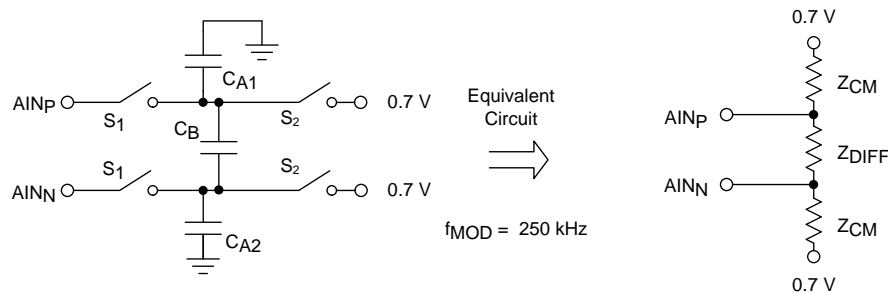

Figure 11. Simplified Analog Input Circuit

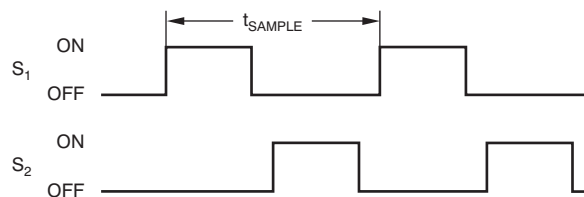

Figure 12. S₁ and S₂ Switch Timing

The common-mode input impedance is measured by applying a common-mode signal to the shorted A_{INP} and A_{INN} inputs and measuring the average current consumed by each pin. The common-mode input impedance changes depending on the full-scale range, but is approximately 6 M Ω for the default full-scale range. In Figure 11, the common-mode input impedance is Z_{CM} .

The differential input impedance is measured by applying a differential signal to A_{INP} and A_{INN} inputs where one input is held at 0.7 V. The current that flows through the pin connected to 0.7 V is the differential current and scales with the full-scale range. In Figure 11, the differential input impedance is Z_{DIFF} .

Make sure to consider the typical value of the input impedance. Unless the input source has a low impedance, the ADS101x input impedance may affect the measurement accuracy. For sources with high-output impedance, buffering may be necessary. Active buffers introduce noise, and also introduce offset and gain errors. Consider all of these factors in high-accuracy applications.

The clock oscillator frequency drifts slightly with temperature; therefore, the input impedances also drift. For most applications, this input impedance drift is negligible, and can be ignored.

Feature Description (continued)

8.3.3 Full-Scale Range (FSR) and LSB Size

A programmable gain amplifier (PGA) is implemented before the $\Delta\Sigma$ ADC of the ADS1014 and ADS1015. The full-scale range is configured by bits PGA[2:0] in the [Config register](#) and can be set to ± 6.144 V, ± 4.096 V, ± 2.048 V, ± 1.024 V, ± 0.512 V, ± 0.256 V. [Table 1](#) shows the FSR together with the corresponding LSB size. [Equation 2](#) shows how to calculate the LSB size from the selected full-scale range.

$$\text{LSB} = \text{FSR} / 2^{12} \quad (2)$$

Table 1. Full-Scale Range and Corresponding LSB Size

FSR	LSB SIZE
± 6.144 V ⁽¹⁾	3 mV
± 4.096 V ⁽¹⁾	2 mV
± 2.048 V	1 mV
± 1.024 V	0.5 mV
± 0.512 V	0.25 mV
± 0.256 V	0.125 mV

(1) This parameter expresses the full-scale range of the ADC scaling. Do not apply more than VDD + 0.3 V to the analog inputs of the device.

The FSR of the ADS1013 is fixed at ± 2.048 V.

Analog input voltages must never exceed the analog input voltage limits given in the [Absolute Maximum Ratings](#). If a VDD supply voltage greater than 4 V is used, the ± 6.144 V full-scale range allows input voltages to extend up to the supply. Although in this case (or whenever the supply voltage is less than the full-scale range, a full-scale ADC output code cannot be obtained. For example, with VDD = 3.3 V and FSR = ± 4.096 V, only signals up to $V_{IN} = \pm 3.3$ V can be measured. The code range that represents voltages $|V_{IN}| > 3.3$ V is not used in this case.

8.3.4 Voltage Reference

The ADS101x have an integrated voltage reference. An external reference cannot be used with these devices. Errors associated with the initial voltage reference accuracy and the reference drift with temperature are included in the gain error and gain drift specifications in the [Electrical Characteristics](#) table.

8.3.5 Oscillator

The ADS101x have an integrated oscillator running at 1 MHz. No external clock can be applied to operate these devices. The internal oscillator drifts over temperature and time. The output data rate scales proportionally with the oscillator frequency.

8.3.6 Output Data Rate and Conversion Time

The ADS101x offer programmable output data rates. Use the DR[2:0] bits in the [Config register](#) to select output data rates of 128 SPS, 250 SPS, 490 SPS, 920 SPS, 1600 SPS, 2400 SPS, or 3300 SPS.

Conversions in the ADS101x settle within a single cycle; thus, the conversion time is equal to 1 / DR.

8.3.7 Digital Comparator (ADS1014 and ADS1015 Only)

The ADS1015 and ADS1014 feature a programmable digital comparator that can issue an alert on the ALERT/RDY pin. The COMP_MODE bit in the [Config register](#) configures the comparator as either a traditional comparator or a window comparator. In traditional comparator mode, the ALERT/RDY pin asserts (active low by default) when conversion data exceeds the limit set in the high-threshold register (Hi_thresh). The comparator then deasserts only when the conversion data falls below the limit set in the low-threshold register (Lo_thresh). In window comparator mode, the ALERT/RDY pin asserts when the conversion data exceed the Hi_thresh register or fall below the Lo_thresh register value.

ADS1013, ADS1014, ADS1015

SBAS473E –MAY 2009–REVISED JANUARY 2018

www.ti.com

In either window or traditional comparator mode, the comparator can be configured to latch after being asserted by the COMP_LAT bit in the Config register. This setting causes the assertion to remain even if the input signal is not beyond the bounds of the threshold registers. This latched assertion can only be cleared by issuing an SMBus alert response or by reading the [Conversion register](#). The ALERT/RDY pin can be configured as active high or active low by the COMP_POL bit in the Config register. Operational diagrams for both the comparator modes are shown in [Figure 13](#).

The comparator can also be configured to activate the ALERT/RDY pin only after a set number of successive readings exceed the threshold values set in the threshold registers (Hi_thresh and Lo_thresh). The COMP_QUE[1:0] bits in the Config register configures the comparator to wait for one, two, or four readings beyond the threshold before activating the ALERT/RDY pin. The COMP_QUE[1:0] bits can also disable the comparator function, and put the ALERT/RDY pin into a high state.

8.3.8 Conversion Ready Pin (ADS1014 and ADS1015 Only)

The ALERT/RDY pin can also be configured as a conversion ready pin. Set the most-significant bit of the Hi_thresh register to 1 and the most-significant bit of Lo_thresh register to 0 to enable the pin as a conversion ready pin. The COMP_POL bit continues to function as expected. Set the COMP_QUE[1:0] bits to any 2-bit value other than 11 to keep the ALERT/RDY pin enabled, and allow the conversion ready signal to appear at the ALERT/RDY pin output. The COMP_MODE and COMP_LAT bits no longer control any function. When configured as a conversion ready pin, ALERT/RDY continues to require a pullup resistor. The ADS101x provide an approximately 8- μ s conversion ready pulse on the ALERT/RDY pin at the end of each conversion in continuous-conversion mode, as shown in Figure 14. In single-shot mode, the ALERT/RDY pin asserts low at the end of a conversion if the COMP_POL bit is set to 0.

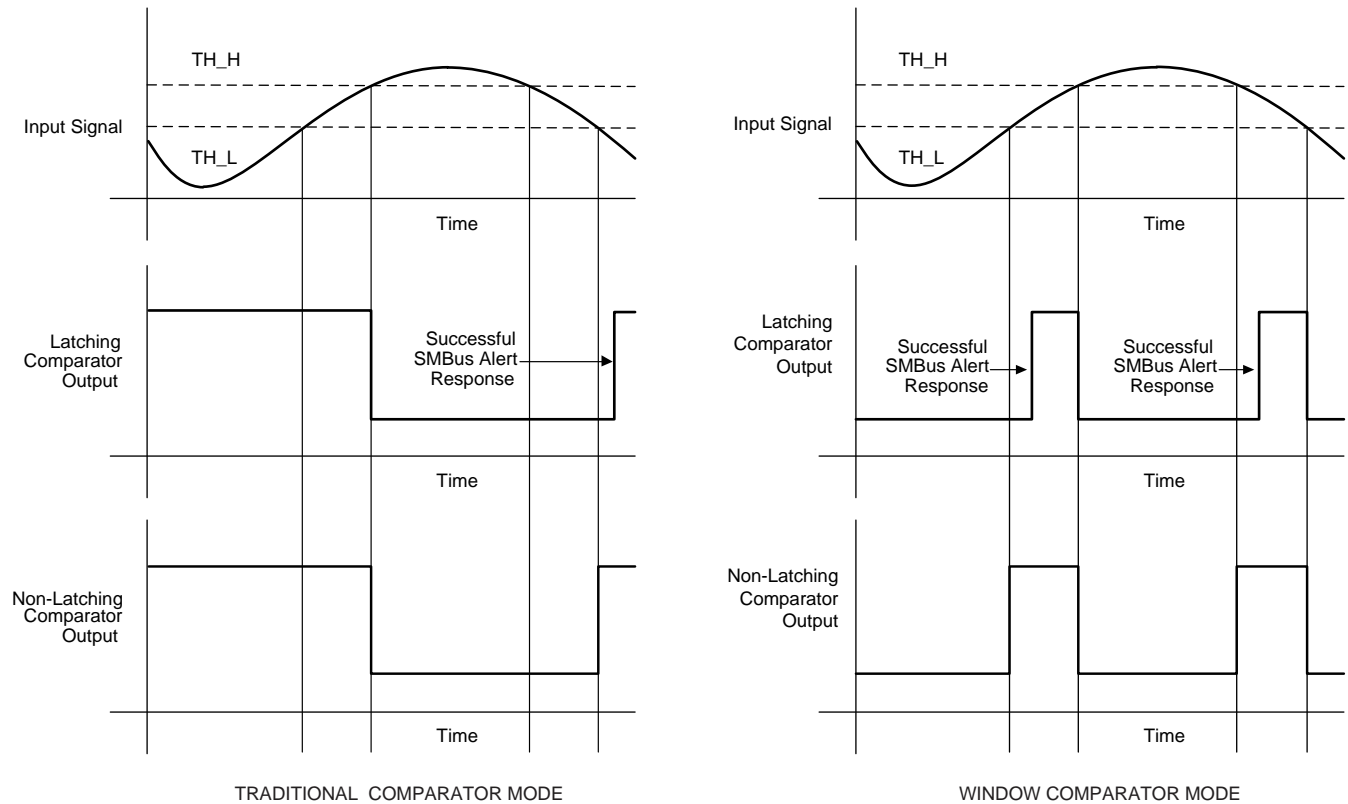

Figure 13. ALERT Pin Timing Diagram

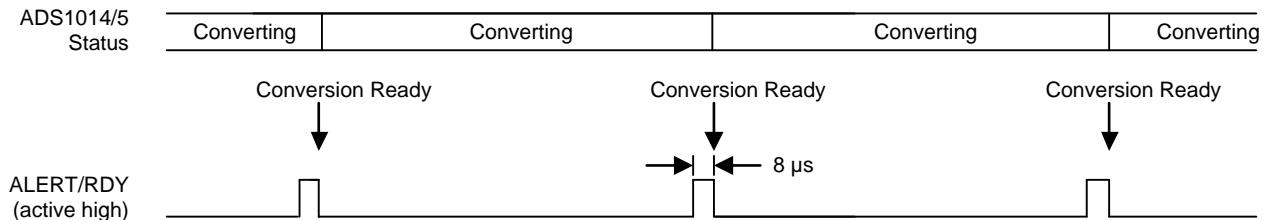

Figure 14. Conversion Ready Pulse in Continuous-Conversion Mode

8.3.9 SMBus Alert Response

In latching comparator mode ($COMP_LAT = 1$), the ALERT/RDY pin asserts when the comparator detects a conversion that exceeds the upper or lower threshold value. This assertion is latched and can be cleared only by reading conversion data, or by issuing a successful SMBus alert response and reading the asserting device I²C address. If conversion data exceed the upper or lower threshold values after being cleared, the pin reasserts. This assertion does not affect conversions that are already in progress. The ALERT/RDY pin is an open-drain output. This architecture allows several devices to share the same interface bus. When disabled, the pin holds a high state so that the pin does not interfere with other devices on the same bus line.

When the master senses that the ALERT/RDY pin has latched, the master issues an SMBus alert command (00011001) to the I²C bus. Any ADS1014 and ADS1015 data converters on the I²C bus with the ALERT/RDY pins asserted respond to the command with the slave address. If more than one ADS101x on the I²C bus assert the latched ALERT/RDY pin, arbitration during the address response portion of the SMBus alert determines which device clears assertion. The device with the lowest I²C address always wins arbitration. If a device loses arbitration, the device does not clear the comparator output pin assertion. The master then repeats the SMBus alert response until all devices have the respective assertions cleared. In window comparator mode, the SMBus alert status bit indicates a 1 if signals exceed the high threshold, and a 0 if signals exceed the low threshold.

8.4 Device Functional Modes

8.4.1 Reset and Power-Up

The ADS101x reset on power-up and set all the bits in the [Config register](#) to the respective default settings. The ADS101x enter a power-down state after completion of the reset process. The device interface and digital blocks are active, but no data conversions are performed. The initial power-down state of the ADS101x relieves systems with tight power-supply requirements from encountering a surge during power-up.

The ADS101x respond to the I²C general-call reset command. When the ADS101x receive a general-call reset command (06h), an internal reset is performed as if the device is powered-up.

8.4.2 Operating Modes

The ADS101x operate in one of two modes: continuous-conversion or single-shot. The MODE bit in the Config register selects the respective operating mode.

8.4.2.1 Single-Shot Mode

When the MODE bit in the Config register is set to 1, the ADS101x enter a power-down state, and operate in single-shot mode. This power-down state is the default state for the ADS101x when power is first applied. Although powered down, the devices still respond to commands. The ADS101x remain in this power-down state until a 1 is written to the operational status (OS) bit in the Config register. When the OS bit is asserted, the device powers up in approximately 25 μ s, resets the OS bit to 0, and starts a single conversion. When conversion data are ready for retrieval, the device powers down again. Writing a 1 to the OS bit while a conversion is ongoing has no effect. To switch to continuous-conversion mode, write a 0 to the MODE bit in the Config register.

8.4.2.2 Continuous-Conversion Mode

In continuous-conversion mode (MODE bit set to 0), the ADS101x perform conversions continuously. When a conversion is complete, the ADS101x place the result in the [Conversion register](#) and immediately begin another conversion. When writing new configuration settings, the currently ongoing conversion completes with the previous configuration settings. Thereafter, continuous conversions with the new configuration settings start. To switch to single-shot conversion mode, write a 1 to the MODE bit in the configuration register or reset the device.

8.4.3 Duty Cycling For Low Power

The noise performance of a $\Delta\Sigma$ ADC generally improves when lowering the output data rate because more samples of the internal modulator are averaged to yield one conversion result. In applications where power consumption is critical, the improved noise performance at low data rates may not be required. For these applications, the ADS101x support duty cycling that yield significant power savings by periodically requesting high data rate readings at an effectively lower data rate. For example, an ADS101x in power-down state with a data rate set to 3300 SPS can be operated by a microcontroller that instructs a single-shot conversion every 7.8 ms (128 SPS). A conversion at 3300 SPS only requires approximately 0.3 ms, so the ADS101x enter power-down state for the remaining 7.5 ms. In this configuration, the ADS101x consume approximately 1/25th the power that is otherwise consumed in continuous-conversion mode. The duty cycling rate is completely arbitrary and is defined by the master controller. The ADS101x offer lower data rates that do not implement duty cycling and also offer improved noise performance if required.

8.5 Programming

8.5.1 I²C Interface

The ADS101x communicate through an I²C interface. I²C is a two-wire open-drain interface that supports multiple devices and masters on a single bus. Devices on the I²C bus only drive the bus lines low by connecting them to ground; the devices never drive the bus lines high. Instead, the bus wires are pulled high by pullup resistors, so the bus wires are always high when no device is driving them low. As a result of this configuration, two devices cannot conflict. If two devices drive the bus simultaneously, there is no driver contention.

Communication on the I²C bus always takes place between two devices, one acting as the master and the other as the slave. Both the master and slave can read and write, but the slave can only do so under the direction of the master. Some I²C devices can act as a master or slave, but the ADS101x can only act as a slave device.

An I²C bus consists of two lines: SDA and SCL. SDA carries data; SCL provides the clock. All data are transmitted across the I²C bus in groups of eight bits. To send a bit on the I²C bus, drive the SDA line to the appropriate level while SCL is low (a low on SDA indicates the bit is zero; a high indicates the bit is one). After the SDA line settles, the SCL line is brought high, then low. This pulse on SCL clocks the SDA bit into the receiver shift register. If the I²C bus is held idle for more than 25 ms, the bus times out.

The I²C bus is bidirectional; that is, the SDA line is used for both transmitting and receiving data. When the master reads from a slave, the slave drives the data line; when the master sends to a slave, the master drives the data line. The master always drives the clock line. The ADS101x cannot act as a master, and therefore can never drive SCL.

Most of the time the bus is idle; no communication occurs, and both lines are high. When communication takes place, the bus is active. Only a master device can start a communication and initiate a START condition on the bus. Normally, the data line is only allowed to change state while the clock line is low. If the data line changes state while the clock line is high, it is either a START condition or a STOP condition. A START condition occurs when the clock line is high, and the data line goes from high to low. A STOP condition occurs when the clock line is high, and the data line goes from low to high.

After the master issues a START condition, the master sends a byte that indicates with which slave device to communicate. This byte is called the *address byte*. Each device on an I²C bus has a unique 7-bit address to which it responds. The master sends an address in the address byte, together with a bit that indicates whether the master wishes to read from or write to the slave device.

Every byte (address and data) transmitted on the I²C bus is acknowledged with an *acknowledge* bit. When the master finishes sending a byte (eight data bits) to a slave, the master stops driving SDA and waits for the slave to acknowledge the byte. The slave acknowledges the byte by pulling SDA low. The master then sends a clock pulse to clock the acknowledge bit. Similarly, when the master completes reading a byte, the master pulls SDA low to acknowledge this completion to the slave. The master then sends a clock pulse to clock the bit. The master always drives the clock line.

If a device is not present on the bus, and the master attempts to address it, it receives a *not-acknowledge* because no device is present at that address to pull the line low. A not-acknowledge is performed by simply leaving SDA high during an acknowledge cycle.

When the master has finished communicating with a slave, it may issue a STOP condition. When a STOP condition is issued, the bus becomes idle again. The master may also issue another START condition. When a START condition is issued while the bus is active, it is called a repeated start condition.

The [Timing Requirements](#) section shows a timing diagram for the ADS101x I²C communication.

Programming (continued)

8.5.1.1 I²C Address Selection

The ADS101x have one address pin, ADDR, that configures the I²C address of the device. This pin can be connected to GND, VDD, SDA, or SCL, allowing for four different addresses to be selected with one pin, as shown in [Table 2](#). The state of address pin ADDR is sampled continuously. Use the GND, VDD and SCL addresses first. If SDA is used as the device address, hold the SDA line low for at least 100 ns after the SCL line goes low to make sure the device decodes the address correctly during I²C communication.

Table 2. ADDR Pin Connection and Corresponding Slave Address

ADDR PIN CONNECTION	SLAVE ADDRESS
GND	1001000
VDD	1001001
SDA	1001010
SCL	1001011

8.5.1.2 I²C General Call

The ADS101x respond to the I²C general call address (0000000) if the eighth bit is 0. The devices acknowledge the general call address and respond to commands in the second byte. If the second byte is 00000110 (06h), the ADS101x reset the internal registers and enter a power-down state.

8.5.1.3 I²C Speed Modes

The I²C bus operates at one of three speeds. Standard mode allows a clock frequency of up to 100 kHz; fast mode permits a clock frequency of up to 400 kHz; and high-speed mode (also called Hs mode) allows a clock frequency of up to 3.4 MHz. The ADS101x are fully compatible with all three modes.

No special action is required to use the ADS101x in standard or fast mode, but high-speed mode must be activated. To activate high-speed mode, send a special address byte of 00001xxx following the START condition, where xxx are bits unique to the Hs-capable master. This byte is called the Hs master code, and is different from normal address bytes; the eighth bit does not indicate read/write status. The ADS101x do not acknowledge this byte; the I²C specification prohibits acknowledgment of the Hs master code. Upon receiving a master code, the ADS101x switch on Hs mode filters, and communicate at up to 3.4 MHz. The ADS101x switch out of Hs mode with the next STOP condition.

For more information on high-speed mode, consult the I²C specification.

8.5.2 Slave Mode Operations

The ADS101x act as slave receivers or slave transmitters. The ADS101x cannot drive the SCL line as slave devices.

8.5.2.1 Receive Mode

In slave receive mode, the first byte transmitted from the master to the slave consists of the 7-bit device address followed by a low R/W bit. The next byte transmitted by the master is the [Address Pointer register](#). The ADS101x then acknowledge receipt of the Address Pointer register byte. The next two bytes are written to the address given by the register address pointer bits, P[1:0]. The ADS101x acknowledge each byte sent. Register bytes are sent with the most significant byte first, followed by the least significant byte.

8.5.2.2 Transmit Mode

In slave transmit mode, the first byte transmitted by the master is the 7-bit slave address followed by the high R/W bit. This byte places the slave into transmit mode and indicates that the ADS101x are being read from. The next byte transmitted by the slave is the most significant byte of the register that is indicated by the register address pointer bits, P[1:0]. This byte is followed by an acknowledgment from the master. The remaining least significant byte is then sent by the slave and is followed by an acknowledgment from the master. The master may terminate transmission after any byte by not acknowledging or issuing a START or STOP condition.

8.5.3 Writing To and Reading From the Registers

To access a specific register from the ADS101x, the master must first write an appropriate value to register address pointer bits P[1:0] in the [Address Pointer register](#). The Address Pointer register is written to directly after the slave address byte, low R/W bit, and a successful slave acknowledgment. After the Address Pointer register is written, the slave acknowledges, and the master issues a STOP or a repeated START condition.

When reading from the ADS101x, the previous value written to bits P[1:0] determines the register that is read. To change which register is read, a new value must be written to P[1:0]. To write a new value to P[1:0], the master issues a slave address byte with the R/W bit low, followed by the Address Pointer register byte. No additional data has to be transmitted, and a STOP condition can be issued by the master. The master can now issue a START condition and send the slave address byte with the R/W bit high to begin the read. [Figure 22](#) details this sequence. If repeated reads from the same register are desired, there is no need to continually send the Address Pointer register, because the ADS101x store the value of P[1:0] until it is modified by a write operation. However, for every write operation, the Address Pointer register must be written with the appropriate values.

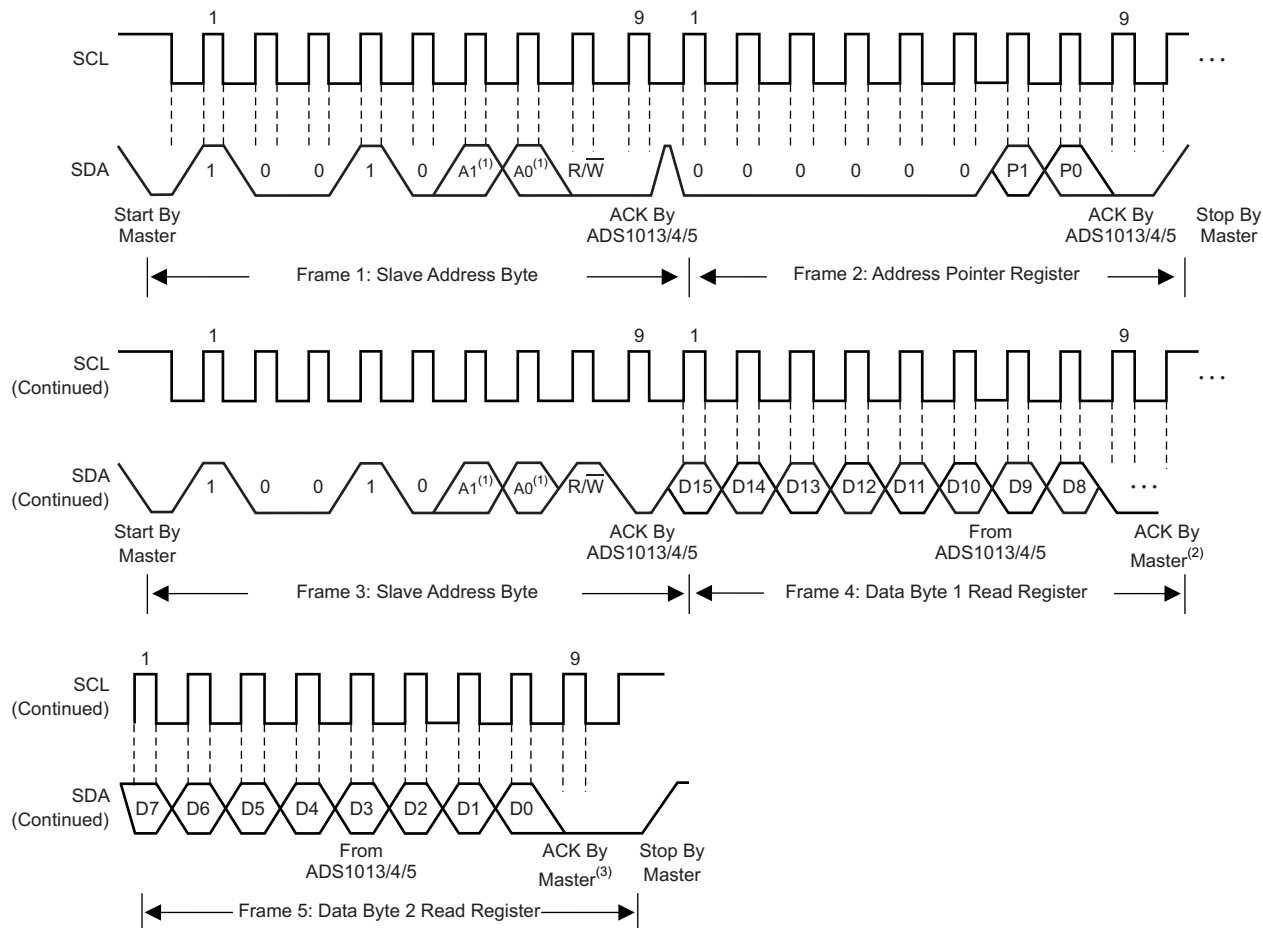

- (1) The values of A0 and A1 are determined by the ADDR pin.
- (2) Master can leave SDA high to terminate a single-byte read operation.
- (3) Master can leave SDA high to terminate a two-byte read operation.

Figure 15. Timing Diagram for Reading From ADS101x

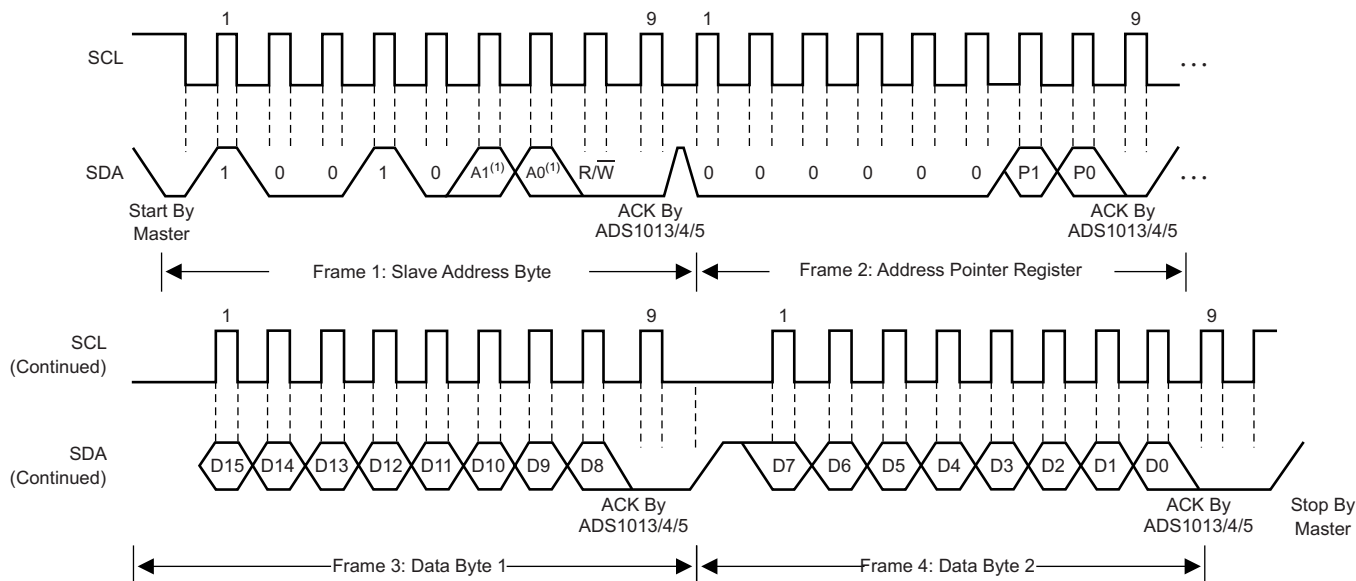

Figure 16. Timing Diagram for Writing to ADS101x

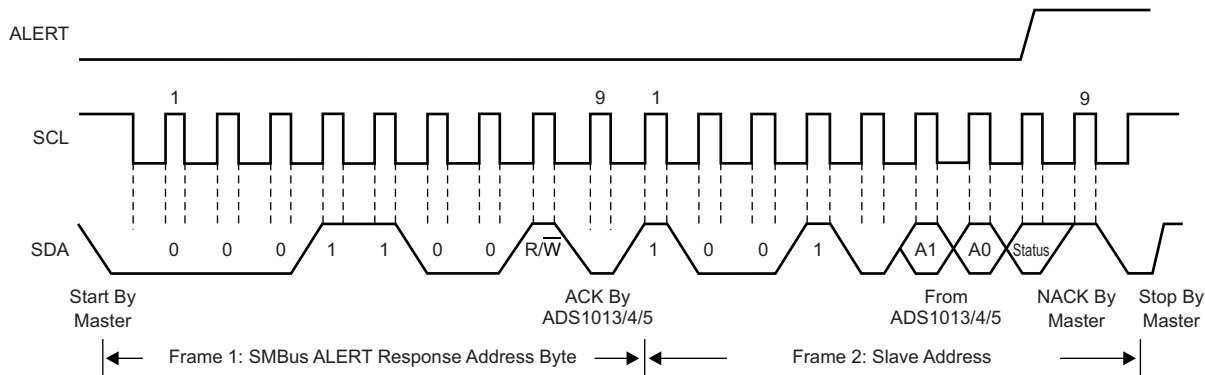

Figure 17. Timing Diagram for SMBus Alert Response

8.5.4 Data Format

The ADS101x provide 12 bits of data in binary two's complement format that is left justified within the 16-bit data word. A positive full-scale (+FS) input produces an output code of 7FF0h and a negative full-scale (–FS) input produces an output code of 8000h. The output clips at these codes for signals that exceed full-scale. Table 3 summarizes the ideal output codes for different input signals. Figure 18 shows code transitions versus input voltage.

Table 3. Input Signal Versus Ideal Output Code

INPUT SIGNAL $V_{IN} = (V_{AINP} - V_{AINN})$	IDEAL OUTPUT CODE ⁽¹⁾⁽¹⁾
$\geq +FS (2^{11} - 1)/2^{11}$	7FF0h
$+FS/2^{11}$	0010h
0	0000h
$-FS/2^{11}$	FFF0h
$\leq -FS$	8000h

(1) Excludes the effects of noise, INL, offset, and gain errors.

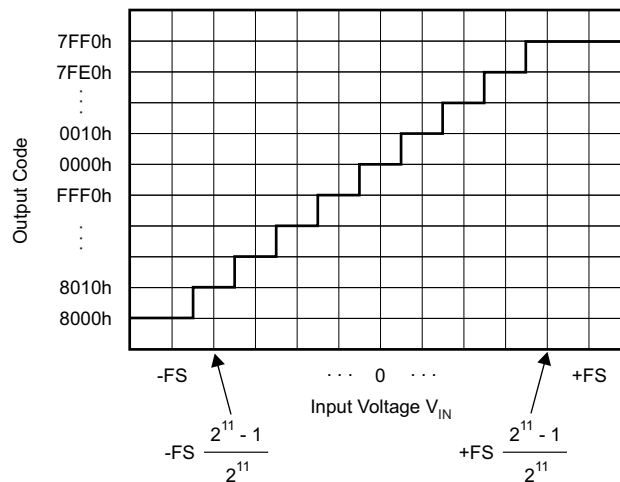

Figure 18. Code Transition Diagram

NOTE

Single-ended signal measurements, where $V_{AINN} = 0\text{ V}$ and $V_{AINP} = 0\text{ V}$ to $+FS$, only use the positive code range from 0000h to 7FF0h. However, because of device offset, the ADS101x can still output negative codes in case V_{AINP} is close to 0 V.

8.6 Register Map

The ADS101x have four registers that are accessible through the I²C interface using the [Address Pointer register](#). The [Conversion register](#) contains the result of the last conversion. The [Config register](#) is used to change the ADS101x operating modes and query the status of the device. The other two registers, Lo_thresh and Hi_thresh, set the threshold values used for the comparator function, and are not available in the ADS1013.

8.6.1 Address Pointer Register (address = N/A) [reset = N/A]

All four registers are accessed by writing to the Address Pointer register; see [Figure 15](#).

Figure 19. Address Pointer Register

7	6	5	4	3	2	1	0
0	0	0	0	0	0	P[1:0]	
W-0h	W-0h	W-0h	W-0h	W-0h	W-0h	W-0h	

LEGEND: R/W = Read/Write; R = Read only; W = Write only; -n = value after reset

Table 4. Address Pointer Register Field Descriptions

Bit	Field	Type	Reset	Description
7:2	Reserved	W	0h	Always write 0h
1:0	P[1:0]	W	0h	Register address pointer 00 : Conversion register 01 : Config register 10 : Lo_thresh register 11 : Hi_thresh register

8.6.2 Conversion Register (P[1:0] = 0h) [reset = 0000h]

The 16-bit Conversion register contains the result of the last conversion in binary two's complement format. Following power-up, the Conversion register is cleared to 0, and remains 0 until the first conversion is completed.

Figure 20. Conversion Register

15	14	13	12	11	10	9	8
D11	D10	D9	D8	D7	D6	D5	D4
R-0h	R-0h	R-0h	R-0h	R-0h	R-0h	R-0h	R-0h
7	6	5	4	3	2	1	0
D3	D2	D1	D0	Reserved			
R-0h	R-0h	R-0h	R-0h	R-0h	R-0h	R-0h	R-0h

LEGEND: R/W = Read/Write; R = Read only; -n = value after reset

Table 5. Conversion Register Field Descriptions

Bit	Field	Type	Reset	Description
15:4	D[11:0]	R	000h	12-bit conversion result
3:0	Reserved	R	0h	Always Reads back 0h

8.6.3 Config Register (P[1:0] = 1h) [reset = 8583h]

The 16-bit Config register is used to control the operating mode, input selection, data rate, full-scale range, and comparator modes.

Figure 21. Config Register

15	14	13	12	11	10	9	8
OS	MUX[2:0]			PGA[2:0]			MODE
R/W-1h		R/W-0h			R/W-2h		R/W-1h
7	6	5	4	3	2	1	0
DR[2:0]			COMP_MODE	COMP_POL	COMP_LAT	COMP_QUE[1:0]	
R/W-4h			R/W-0h	R/W-0h	R/W-0h	R/W-3h	

LEGEND: R/W = Read/Write; R = Read only; -n = value after reset

Table 6. Config Register Field Descriptions

Bit	Field	Type	Reset	Description
15	OS	R/W	1h	<p>Operational status or single-shot conversion start This bit determines the operational status of the device. OS can only be written when in power-down state and has no effect when a conversion is ongoing.</p> <p>When writing: 0 : No effect 1 : Start a single conversion (when in power-down state)</p> <p>When reading: 0 : Device is currently performing a conversion 1 : Device is not currently performing a conversion</p>
14:12	MUX[2:0]	R/W	0h	<p>Input multiplexer configuration (ADS1015 only) These bits configure the input multiplexer. These bits serve no function on the ADS1013 and ADS1014.</p> <p>000 : AIN_P = AIN0 and AIN_N = AIN1 (default) 001 : AIN_P = AIN0 and AIN_N = AIN3 010 : AIN_P = AIN1 and AIN_N = AIN3 011 : AIN_P = AIN2 and AIN_N = AIN3 100 : AIN_P = AIN0 and AIN_N = GND 101 : AIN_P = AIN1 and AIN_N = GND 110 : AIN_P = AIN2 and AIN_N = GND 111 : AIN_P = AIN3 and AIN_N = GND</p>
11:9	PGA[2:0]	R/W	2h	<p>Programmable gain amplifier configuration These bits set the FSR of the programmable gain amplifier. These bits serve no function on the ADS1013.</p> <p>000 : FSR = ±6.144 V⁽¹⁾ 001 : FSR = ±4.096 V⁽¹⁾ 010 : FSR = ±2.048 V (default) 011 : FSR = ±1.024 V 100 : FSR = ±0.512 V 101 : FSR = ±0.256 V 110 : FSR = ±0.256 V 111 : FSR = ±0.256 V</p>
8	MODE	R/W	1h	<p>Device operating mode This bit controls the operating mode.</p> <p>0 : Continuous-conversion mode 1 : Single-shot mode or power-down state (default)</p>
7:5	DR[2:0]	R/W	4h	<p>Data rate These bits control the data rate setting.</p> <p>000 : 128 SPS 001 : 250 SPS 010 : 490 SPS 011 : 920 SPS 100 : 1600 SPS (default) 101 : 2400 SPS 110 : 3300 SPS 111 : 3300 SPS</p>

(1) This parameter expresses the full-scale range of the ADC scaling. Do not apply more than VDD + 0.3 V to the analog inputs of the device.

Table 6. Config Register Field Descriptions (continued)

Bit	Field	Type	Reset	Description
4	COMP_MODE	R/W	0h	Comparator mode (ADS1014 and ADS1015 only) This bit configures the comparator operating mode. This bit serves no function on the ADS1013. 0 : Traditional comparator (default) 1 : Window comparator
3	COMP_POL	R/W	0h	Comparator polarity (ADS1014 and ADS1015 only) This bit controls the polarity of the ALERT/RDY pin. This bit serves no function on the ADS1013. 0 : Active low (default) 1 : Active high
2	COMP_LAT	R/W	0h	Latching comparator (ADS1014 and ADS1015 only) This bit controls whether the ALERT/RDY pin latches after being asserted or clears after conversions are within the margin of the upper and lower threshold values. This bit serves no function on the ADS1013. 0 : Nonlatching comparator . The ALERT/RDY pin does not latch when asserted (default). 1 : Latching comparator. The asserted ALERT/RDY pin remains latched until conversion data are read by the master or an appropriate SMBus alert response is sent by the master. The device responds with its address, and it is the lowest address currently asserting the ALERT/RDY bus line.
1:0	COMP_QUE[1:0]	R/W	3h	Comparator queue and disable (ADS1014 and ADS1015 only) These bits perform two functions. When set to 11, the comparator is disabled and the ALERT/RDY pin is set to a high-impedance state. When set to any other value, the ALERT/RDY pin and the comparator function are enabled, and the set value determines the number of successive conversions exceeding the upper or lower threshold required before asserting the ALERT/RDY pin. These bits serve no function on the ADS1013. 00 : Assert after one conversion 01 : Assert after two conversions 10 : Assert after four conversions 11 : Disable comparator and set ALERT/RDY pin to high-impedance (default)

8.6.4 Lo_thresh (P[1:0] = 2h) [reset = 8000h] and Hi_thresh (P[1:0] = 3h) [reset = 7FFFh] Registers

The upper and lower threshold values used by the comparator are stored in two 16-bit registers in two's complement format. The comparator is implemented as a digital comparator; therefore, the values in these registers must be updated whenever the PGA settings are changed.

The conversion-ready function of the ALERT/RDY pin is enabled by setting the Hi_thresh register MSB to 1 and the Lo_thresh register MSB to 0. To use the comparator function of the ALERT/RDY pin, the Hi_thresh register value must always be greater than the Lo_thresh register value. The threshold register formats are shown in Figure 22. When set to RDY mode, the ALERT/RDY pin outputs the OS bit when in single-shot mode, and provides a continuous-conversion ready pulse when in continuous-conversion mode.

Figure 22. Lo_thresh Register

15		14		13		12		11		10		9		8	
Lo_thresh11	Lo_thresh10	Lo_thresh9	Lo_thresh8	Lo_thresh7	Lo_thresh6	Lo_thresh5	Lo_thresh4								
R/W-1h	R/W-0h	R/W-0h	R/W-0h	R/W-0h	R/W-0h	R/W-0h	R/W-0h								
7		6		5		4		3		2		1		0	
Lo_thresh3	Lo_thresh2	Lo_thresh1	Lo_thresh0	0	0	0	0								
R/W-0h	R/W-0h	R/W-0h	R/W-0h	R-0h	R-0h	R-0h	R-0h								

LEGEND: R/W = Read/Write; R = Read only; -n = value after reset

Figure 23. Hi_thresh Register

15		14		13		12		11		10		9		8	
Hi_thresh11	Hi_thresh10	Hi_thresh9	Hi_thresh8	Hi_thresh7	Hi_thresh6	Hi_thresh5	Hi_thresh4								
R/W-0h	R/W-1h	R/W-1h	R/W-1h	R/W-1h	R/W-1h	R/W-1h	R/W-1h								
7		6		5		4		3		2		1		0	
Hi_thresh3	Hi_thresh2	Hi_thresh1	Hi_thresh0	1	1	1	1								
R/W-1h	R/W-1h	R/W-1h	R/W-1h	R-1h	R-1h	R-1h	R-1h								

LEGEND: R/W = Read/Write; R = Read only; -n = value after reset

Table 7. Lo_thresh and Hi_thresh Register Field Descriptions

Bit	Field	Type	Reset	Description
15:4	Lo_thresh[11:0]	R/W	800h	Low threshold value
15:4	Hi_thresh[11:0]	R/W	7FFFh	High threshold value

9 Application and Implementation

NOTE

Information in the following applications sections is not part of the TI component specification, and TI does not warrant its accuracy or completeness. TI's customers are responsible for determining suitability of components for their purposes. Customers should validate and test their design implementation to confirm system functionality.

9.1 Application Information

The following sections give example circuits and suggestions for using the ADS101x in various situations.

9.1.1 Basic Connections

The principle I²C connections for the ADS1015 are shown in Figure 24.

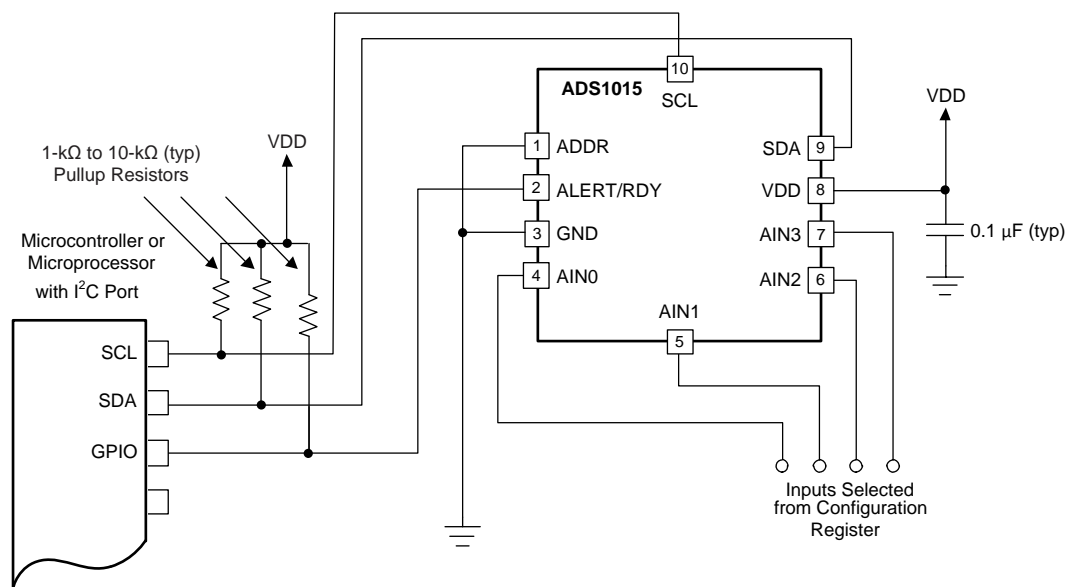

Copyright © 2016, Texas Instruments Incorporated

Figure 24. Typical Connections of the ADS1015

The fully-differential voltage input of the ADS101x is ideal for connection to differential sources with moderately low source impedance, such as thermocouples and thermistors. Although the ADS101x can read bipolar differential signals, these devices cannot accept negative voltages on either input.

The ADS101x draw transient currents during conversion. A 0.1-μF power-supply bypass capacitor supplies the momentary bursts of extra current required from the supply.

The ADS101x interface directly to standard mode, fast mode, and high-speed mode I²C controllers. Any microcontroller I²C peripheral, including master-only and single-master I²C peripherals, operates with the ADS101x. The ADS101x does not perform clock-stretching (that is, the device never pulls the clock line low), so it is not necessary to provide for this function unless other clock-stretching devices are on the same I²C bus.

Pullup resistors are required on both the SDA and SCL lines because I²C bus drivers are open drain. The size of these resistors depends on the bus operating speed and capacitance of the bus lines. Higher-value resistors consume less power, but increase the transition times on the bus, thus limiting the bus speed. Lower-value resistors allow higher speed, but at the expense of higher power consumption. Long bus lines have higher capacitance and require smaller pullup resistors to compensate. Do not use resistors that are too small because the bus drivers may not be able to pull the bus lines low.

Application Information (continued)

9.1.2 Single-Ended Inputs

The ADS1013 and ADS1014 can measure one, and the ADS1015 up to four, single-ended signals. The ADS1013 and ADS1014 can measure single-ended signals by connecting AIN1 to GND externally. The ADS1015 measures single-ended signals by appropriate configuration of the MUX[2:0] bits in the [Config register](#). [Figure 25](#) shows a single-ended connection scheme for ADS1015. The single-ended signal ranges from 0 V up to positive supply or +FS, whichever is lower. Negative voltages cannot be applied to these devices because the ADS101x can only accept positive voltages with respect to ground. The ADS101x do not lose linearity within the input range.

The ADS101x offer a differential input voltage range of \pm FSR. Single-ended configurations use only one-half of the full-scale input voltage range. Differential configurations maximize the dynamic range of the ADC, and provide better common-mode noise rejection than single-ended configurations.

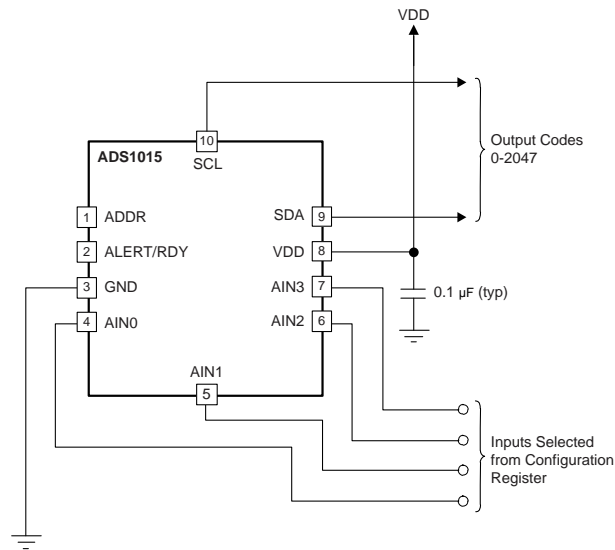

Copyright © 2016, Texas Instruments Incorporated

NOTE: Digital pin connections omitted for clarity.

Figure 25. Measuring Single-Ended Inputs

The ADS1015 also allows AIN3 to serve as a common point for measurements by appropriate setting of the MUX[2:0] bits. AIN0, AIN1, and AIN2 can all be measured with respect to AIN3. In this configuration, the ADS1015 operates with inputs, where AIN3 serves as the common point. This ability improves the usable range over the single-ended configuration because negative differential voltages are allowed when $GND < V_{(AIN3)} < VDD$; however, common-mode noise attenuation is not offered.

9.1.3 Input Protection

The ADS101x are fabricated in a small-geometry, low-voltage process. The analog inputs feature protection diodes to the supply rails. However, the current-handling ability of these diodes is limited, and the ADS101x can be permanently damaged by analog input voltages that exceed approximately 300 mV beyond the rails for extended periods. One way to protect against overvoltage is to place current-limiting resistors on the input lines. The ADS101x analog inputs can withstand continuous currents as large as 10 mA.

9.1.4 Unused Inputs and Outputs

Either float unused analog inputs, or tie the unused analog inputs to midsupply or VDD. Connecting unused analog inputs to GND is possible, but may yield higher leakage currents than the previous options.

Either float NC (not-connected) pins, or tie the NC pins to GND. If the ALERT/RDY output pin is not used, leave the pin unconnected or tie the pin to VDD using a weak pullup resistor.

Application Information (continued)

9.1.5 Analog Input Filtering

Analog input filtering serves two purposes:

1. Limits the effect of aliasing during the sampling process
2. Reduces external noise from being a part of the measurement

Aliasing occurs when frequency components are present in the input signal that are higher than half the sampling frequency of the ADC (also known as the *Nyquist frequency*). These frequency components fold back and show up in the actual frequency band of interest below half the sampling frequency. The filter response of the digital filter repeats at multiples of the sampling frequency, also known as the modulator frequency (f_{MOD}), as shown in Figure 26. Signals or noise up to a frequency where the filter response repeats are attenuated to a certain amount by the digital filter depending on the filter architecture. Any frequency components present in the input signal around the modulator frequency, or multiples thereof, are not attenuated and alias back into the band of interest, unless attenuated by an external analog filter.

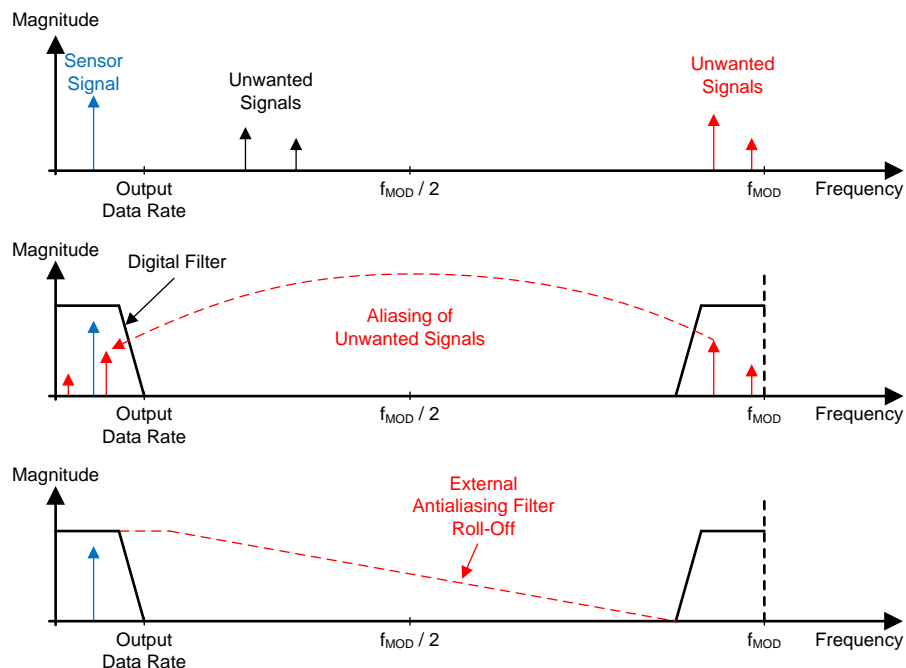

Figure 26. Effect of Aliasing

Many sensor signals are inherently band-limited; for example, the output of a thermocouple has a limited rate of change. In this case, the sensor signal does not alias back into the pass-band when using a $\Delta\Sigma$ ADC. However, any noise pick-up along the sensor wiring or the application circuitry can potentially alias into the pass-band. Power line-cycle frequency and harmonics are one common noise source. External noise can also be generated from electromagnetic interference (EMI) or radio frequency interference (RFI) sources, such as nearby motors and cellular phones. Another noise source typically exists on the printed-circuit-board (PCB) itself in the form of clocks and other digital signals. Analog input filtering helps remove unwanted signals from affecting the measurement result.

A first-order resistor-capacitor (RC) filter is (in most cases) sufficient to either totally eliminate aliasing, or to reduce the effect of aliasing to a level within the noise floor of the sensor. Ideally, any signal beyond $f_{MOD} / 2$ is attenuated to a level below the noise floor of the ADC. The digital filter of the ADS101x attenuate signals to a certain degree. In addition, noise components are usually smaller in magnitude than the actual sensor signal. Therefore, use a first-order RC filter with a cutoff frequency set at the output data rate or 10x higher as a generally good starting point for a system design.

Application Information (continued)

9.1.6 Connecting Multiple Devices

It is possible to connect up to four ADS101x devices to a single I²C bus using different address pin configurations for each device. Use the address pin to set the ADS101x to one of four different I²C addresses. Use the GND, VDD and SCL addresses first. If SDA is used as the device address, hold the SDA line low for at least 100 ns after the SCL line goes low to make sure the device decodes the address correctly during I²C communication. An example showing four ADS101x devices on the same I²C bus is shown in Figure 27. One set of pullup resistors is required per bus. The pullup resistor values may need to be lowered to compensate for the additional bus capacitance presented by multiple devices and increased line length.

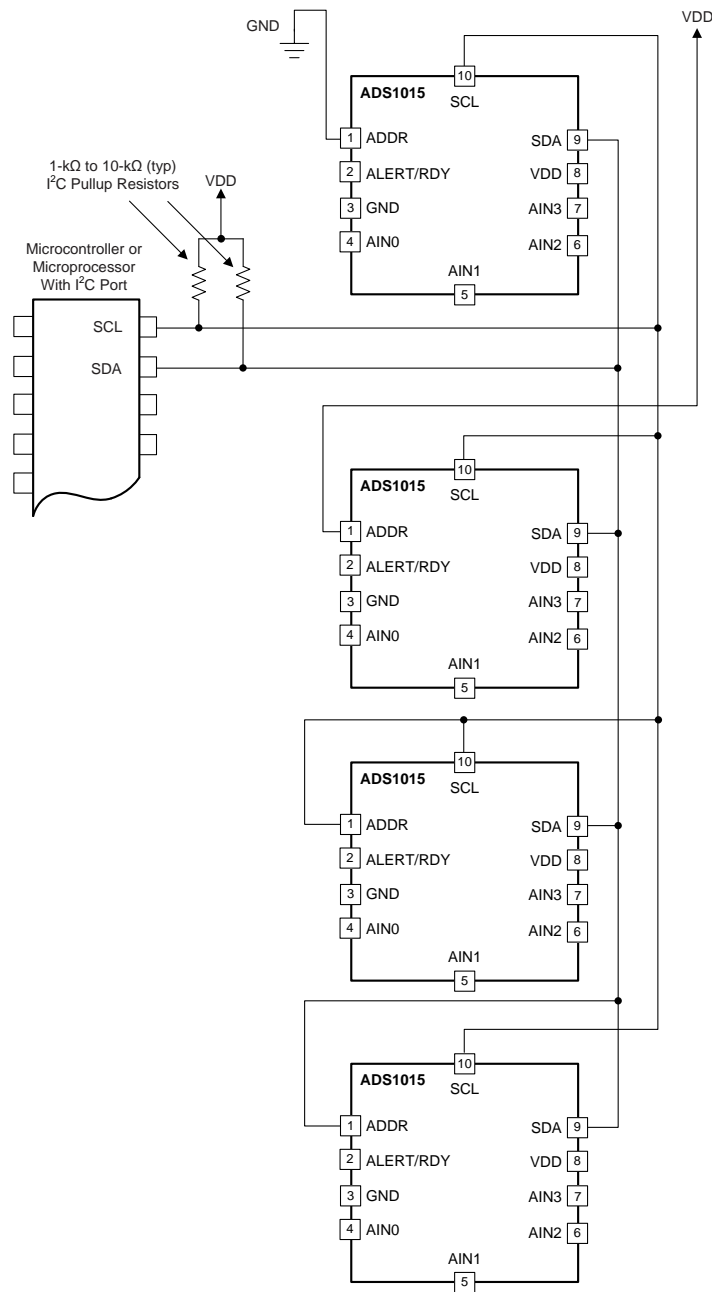

Copyright © 2016, Texas Instruments Incorporated

NOTE: ADS101x power and input connections omitted for clarity. The ADDR pin selects the I²C address.

Figure 27. Connecting Multiple ADS101x Devices

Application Information (continued)

9.1.7 Quickstart Guide

This section provides a brief example of ADS101x communications. See subsequent sections of this data sheet for more detailed explanations. Hardware for this design includes: one ADS101x configured with an I²C address of 1001000; a microcontroller with an I²C interface; discrete components such as resistors, capacitors, and serial connectors; and a 2 V to 5 V power supply. **Figure 28** shows the basic hardware configuration.

The ADS101x communicate with the master (microcontroller) through an I²C interface. The master provides a clock signal on the SCL pin and data are transferred using the SDA pin. The ADS101x never drive the SCL pin. For information on programming and debugging the microcontroller being used, see the device-specific product data sheet.

The first byte sent by the master is the ADS101x address, followed by the R/W bit that instructs the ADS101x to listen for a subsequent byte. The second byte is the **Address Pointer register** byte. The third and fourth bytes sent from the master are written to the register indicated in register address pointer bits P[1:0]. See **Figure 15** and **Figure 16** for read and write operation timing diagrams, respectively. All read and write transactions with the ADS101x must be preceded by a START condition, and followed by a STOP condition.

For example, to write to the configuration register to set the ADS101x to continuous-conversion mode and then read the conversion result, send the following bytes in this order:

1. **Write to Config register:**
 - First byte: 0b10010000 (first 7-bit I²C address followed by a low R/W bit)
 - Second byte: 0b00000001 (points to Config register)
 - Third byte: 0b10000100 (MSB of the Config register to be written)
 - Fourth byte: 0b10000011 (LSB of the Config register to be written)
2. **Write to Address Pointer register:**
 - First byte: 0b10010000 (first 7-bit I²C address followed by a low R/W bit)
 - Second byte: 0b00000000 (points to Conversion register)
3. **Read Conversion register:**
 - First byte: 0b10010001 (first 7-bit I²C address followed by a high R/W bit)
 - Second byte: the ADS101x response with the MSB of the Conversion register
 - Third byte: the ADS101x response with the LSB of the Conversion register

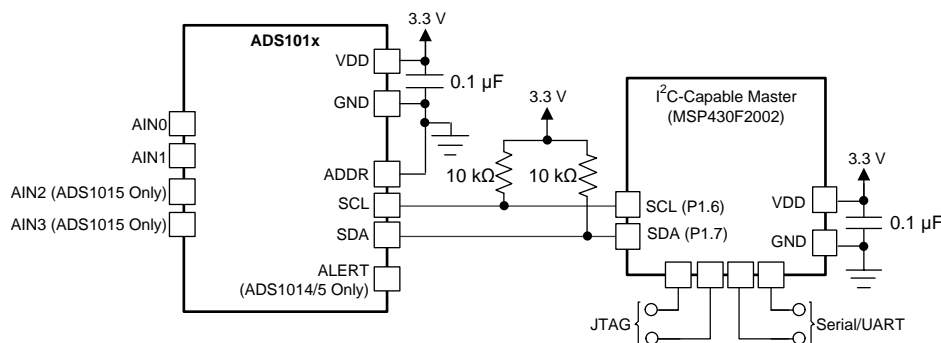

Copyright © 2016, Texas Instruments Incorporated

Figure 28. Basic Hardware Configuration

9.2 Typical Application

Shunt-based, current-measurement solutions are widely used to monitor load currents. Low-side, current-shunt measurements are independent of the bus voltage because the shunt common-mode voltage is near ground. [Figure 29](#) shows an example circuit for a bidirectional, low-side, current-shunt measurement system. The load current is determined by measuring the voltage across the shunt resistor that is amplified and level-shifted by a low-drift operational amplifier, [OPA333](#). The OPA333 output voltage is digitized with [ADS1015](#) and sent to the microcontroller using the I²C interface. This circuit is capable of measuring bidirectional currents flowing through the shunt resistor with great accuracy and precision.

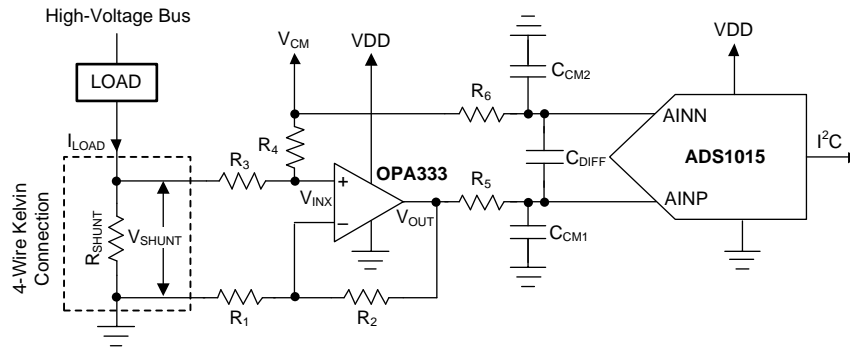

Figure 29. Low-Side Current Shunt Monitoring

9.2.1 Design Requirements

[Table 8](#) shows the design parameters for this application.

Table 8. Design Parameters

DESIGN PARAMETER	VALUE
Supply voltage (VDD)	5 V
Voltage across Shunt Resistor (V_{SHUNT})	± 50 mV
Output Data Rate (DR)	≥ 200 readings per second
Typical measurement accuracy at $T_A = 25^\circ\text{C}$ ⁽¹⁾	$\pm 0.25\%$

(1) Does not account for inaccuracy of shunt resistor and the precision resistors used in the application.

9.2.2 Detailed Design Procedure

The first stage of the application circuit consists of an OPA333 in a noninverting summing amplifier configuration and serves two purposes:

- To level-shift the ground-referenced signal to allow bidirectional current measurements while running off a unipolar supply. The voltage across the shunt resistor, V_{SHUNT} , is level-shifted by a common-mode voltage, V_{CM} , as shown in [Figure 29](#). The level-shifted voltage, V_{INX} , at the noninverting input is given by [Equation 3](#).

$$V_{INX} = (V_{CM} \cdot R_3 + V_{SHUNT} \cdot R_4) / (R_3 + R_4) \quad (3)$$

- To amplify the level-shifted voltage (V_{INX}). The OPA333 is configured in a noninverting gain configuration with the output voltage, V_{OUT} , given by [Equation 4](#).

$$V_{OUT} = V_{INX} \cdot (1 + R_2 / R_1) \quad (4)$$

Using [Equation 3](#) and [Equation 4](#), V_{OUT} is given as a function of V_{SHUNT} and V_{CM} by [Equation 5](#).

$$V_{OUT} = (V_{CM} \cdot R_3 + V_{SHUNT} \cdot R_4) / (R_3 + R_4) \cdot (1 + R_2 / R_1) \quad (5)$$

Using [Equation 5](#) the ADC differential input voltage, before the first-order RC filter, is given by [Equation 6](#).

$$V_{OUT} - V_{CM} = V_{SHUNT} \cdot (1 + R_2 / R_1) / (1 + R_4 / R_3) + V_{CM} \cdot (R_2 / R_1 - R_3 / R_4) / (1 + R_3 / R_4) \quad (6)$$

If $R_1 = R_3$ and $R_2 = R_4$, [Equation 6](#) is simplified to [Equation 7](#).

$$V_{OUT} - V_{CM} = V_{SHUNT} \cdot (1 + R_2 / R_1) / (1 + R_4 / R_3) \quad (7)$$

9.2.2.1 Shunt Resistor Considerations

A shunt resistor (R_{SHUNT}) is an accurate resistance inserted in series with the load as shown in [Figure 29](#). If the absolute voltage drop across the shunt, $|V_{SHUNT}|$, is a larger percentage of the bus voltage, the voltage drop may reduce the overall efficiency and system performance. If $|V_{SHUNT}|$ is too low, measuring the small voltage drop requires careful design attention and proper selection of the ADC, operation amplifier, and precision resistors. Make sure that the absolute voltage at the shunt terminals does not result in violation of the input common-mode voltage range requirements of the operational amplifier. The power dissipation on the shunt resistor increases the temperature because of the current flowing through it. To minimize the measurement errors due to variation in temperature, select a low-drift shunt resistor. To minimize the measurement gain error, select a shunt resistor with low tolerance value. To remove the errors due to stray ground resistance, use a four-wire Kelvin-connected shunt resistor, as shown in [Figure 29](#).

9.2.2.2 Operational Amplifier Considerations

The operational amplifier used for this design example requires the following features:

- Unipolar supply operation (5 V)
- Low input offset voltage ($< 10 \mu\text{V}$) and input offset voltage drift ($< 0.5 \mu\text{V}/^\circ\text{C}$)
- Rail-to-rail input and output capability
- Low thermal and flicker noise
- High common-mode rejection ($> 100 \text{ dB}$)

OPA333 offers all these benefits and is selected for this application.

9.2.2.3 ADC Input Common-Mode Considerations

V_{CM} sets the V_{OUT} common-mode voltage by appropriate selection of precision resistors R_1 , R_2 , R_3 , and R_4 .

If $R_1 = R_3$, $R_2 = R_4$, and $V_{SHUNT} = 0 \text{ V}$, V_{OUT} is given by [Equation 8](#).

$$V_{OUT} = V_{CM} \quad (8)$$

If V_{OUT} is connected to the ADC positive input (AINP) and V_{CM} is connected to the ADC negative input (AINN), V_{CM} appears as a common-mode voltage to the ADC. This configuration allows pseudo-differential measurements and uses the maximum dynamic range of the ADC if V_{CM} is set at midsupply ($V_{DD} / 2$). A resistor divider from V_{DD} to GND followed by a buffer amplifier can be used to generate V_{CM} .

9.2.2.4 Resistor (R_1 , R_2 , R_3 , R_4) Considerations

Proper selection of resistors R_1 , R_2 , R_3 and R_4 is critical for meeting the overall accuracy requirements.

Using [Equation 6](#), the offset term, V_{OUT-OS} , and the gain term, A_{OUT} , of the differential ADC input are represented by [Equation 9](#) and [Equation 10](#) respectively. The error contributions from the first-order RC filters are ignored.

$$V_{OUT-OS} = V_{CM} \cdot (R_2 / R_1 - R_3 / R_4) / (1 + R_3 / R_4) \quad (9)$$

$$A_{OUT} = (1 + R_2 / R_1) / (1 + R_4 / R_3) \quad (10)$$

The tolerance, drift and linearity performance of these resistors is critical to meeting the overall accuracy requirements. In [Equation 9](#), if $R_1 = R_3$ and $R_2 = R_4$, $V_{OUT-OS} = 0 \text{ V}$ and therefore, the common-mode voltage, V_{CM} , only contributes to level-shift V_{SHUNT} and does not introduce any error at the differential ADC inputs. High-precision resistors provide better common-mode rejection from V_{CM} .

9.2.2.5 Noise and Input Impedance Considerations

If $v_{n_{res}}$ represents the input-referred rms noise from all the resistors, $v_{n_{op}}$ represents the input-referred rms noise of OPA333, and $v_{n_{ADC}}$ represents the input-referred rms noise of ADS1015, the total input-referred noise of the entire system, v_N , can be approximated by [Equation 11](#).

$$v_N^2 = v_{n_{res}}^2 + v_{n_{op}}^2 + v_{n_{ADC}} / (1 + R_2 / R_1)^2 \quad (11)$$

It is important to note that the ADC noise contribution, $v_{n_{ADC}}$, is attenuated by the non-inverting gain stage.

If the gain of the noninverting gain stage is high (≥ 5), a good approximation for $v_{n_res}^2$ is given by Equation 12. The noise contribution from resistors R_2 , R_4 , R_5 , and R_6 when referred to the input is smaller in comparison to R_1 and R_3 and can be neglected for approximation purposes.

$$v_{n_res}^2 = 4 \cdot k \cdot T \cdot (R_1 + R_3) \cdot \Delta f$$

where

- k = Boltzmann constant
- T = temperature (in kelvins)
- Δf = noise bandwidth

(12)

An approximation for the input impedance, R_{IN} , of the application circuit is given by Equation 13. R_{IN} can be modeled as a resistor in parallel with the shunt resistor, and can contribute to additional gain error.

$$R_{IN} = R_3 + R_4 \quad (13)$$

From Equation 12 and Equation 13, a trade-off exists between v_N and R_{IN} . If R_3 increases, v_{n_res} increases, and therefore, the total input-referred rms system noise, v_N , increases. If R_3 decreases, the input impedance, R_{IN} , drops, and causes additional gain error.

9.2.2.6 First-order RC Filter Considerations

Although the device digital filter attenuates high-frequency noise, use a first order low-pass RC filter at the ADC inputs to further reject out-of-bandwidth noise and avoid aliasing. A differential low-pass RC filter formed by R_5 , R_6 , and the differential capacitor C_{DIFF} sets the -3 -dB cutoff frequency, f_C , given by Equation 14. These filter resistors produce a voltage drop because of the input currents flowing into and out of the ADC. This voltage drop could contribute to an additional gain error. Limit the filter resistor values to below 1 k Ω .

$$f_C = 1 / [2\pi \cdot (R_5 + R_6) \cdot C_{DIFF}] \quad (14)$$

Two common-mode filter capacitors (C_{CM1} and C_{CM2}) are also added to offer attenuation of high-frequency, common-mode noise components. Select a differential capacitor, C_{DIFF} , that is at least an order of magnitude (10x) larger than these common-mode capacitors because mismatches in these common-mode capacitors can convert common-mode noise into differential noise.

9.2.2.7 Circuit Implementation

Table 9 shows the chosen values for this design.

Table 9. Parameters

PARAMETER	VALUE
V_{CM}	2.5 V
FSR of ADC	± 0.256 V
Output Data Rate	250 SPS
R_1, R_3	1 k Ω ⁽¹⁾
R_2, R_4	5 k Ω ⁽¹⁾
R_5, R_6	100 Ω ⁽¹⁾
C_{DIFF}	0.22 μ F
C_{CM1}, C_{CM2}	0.022 μ F

(1) 1% precision resistors used

Using Equation 5, if V_{SHUNT} ranges from -50 mV to $+50$ mV, the application circuit produces a differential voltage ranging from -0.250 V to $+0.250$ V across the ADC inputs. The ADC is therefore configured at a FSR of ± 0.256 V to maximize the dynamic range of the ADC.

The -3 dB cutoff frequencies of the differential low-pass filter and the common-mode low-pass filters are set at 3.6 kHz and 0.36 kHz, respectively.

R_{SHUNT} typically ranges from 0.01 m Ω to 100 m Ω . Therefore, if $R_1 = R_3 = 1$ k Ω , a good trade-off exists between the circuit input impedance and input referred resistor noise as explained in the Noise and Input Impedance Considerations section.

A simple resistor divider followed by a buffer amplifier is used to generate V_{CM} of 2.5 V from a 5-V supply.

9.2.2.8 Results Summary

A precision voltage source is used to sweep V_{SHUNT} from -50 mV to $+50\text{ mV}$. The application circuit produces a differential voltage of -250 mV to $+250\text{ mV}$ across the ADC inputs. Figure 30 and Figure 31 show the measurement results. The measurements are taken at $T_A = 25^\circ\text{C}$. Although 1% tolerance resistors are used, the exact value of these resistors are measured with a Fluke 4.5 digit multimeter to exclude the errors due to inaccuracy of these resistors. In Figure 30, the x-axis represents V_{SHUNT} and the black line represents the measured digital output voltage in mV. In Figure 31, the x-axis represents V_{SHUNT} , the black line represents the total measurement error in %, the blue line represents the total measurement error in % after excluding the errors from precision resistors and the green line represents the total measurement error in % after excluding the errors from precision resistors and performing a system offset calibration with $V_{SHUNT} = 0\text{ V}$. Table 10 shows a results summary.

Table 10. Results Summary⁽¹⁾

PARAMETER	VALUE
Total error, including errors from 1% precision resistors	1.89%
Total error, excluding errors from 1% precision resistors	0.17%
Total error, after offset calibration, excluding errors from 1% precision resistors	0.11%

(1) $T_A = 25^\circ\text{C}$, not accounting for inaccuracy of shunt resistor.

9.2.3 Application Curves

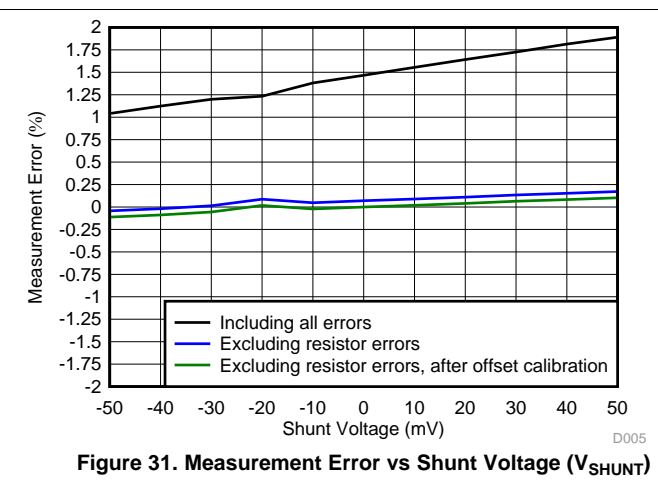
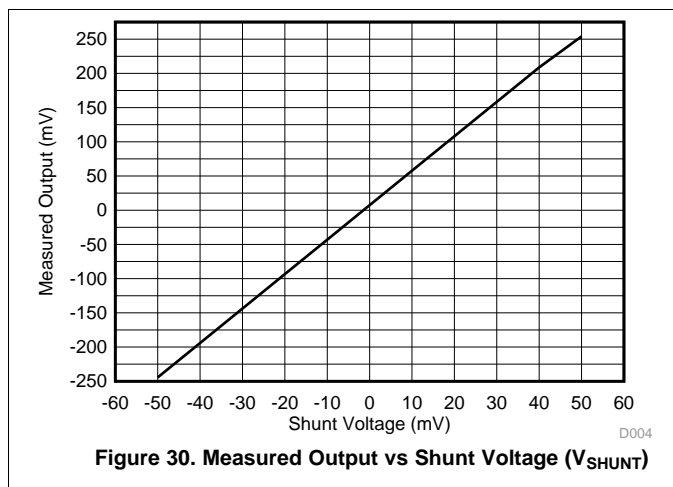

10 Power Supply Recommendations

The device requires a single unipolar supply, VDD, to power both the analog and digital circuitry of the device.

10.1 Power-Supply Sequencing

Wait approximately 50 μ s after VDD is stabilized before communicating with the device to allow the power-up reset process to complete.

10.2 Power-Supply Decoupling

Good power-supply decoupling is important to achieve optimum performance. VDD must be decoupled with at least a 0.1- μ F capacitor, as shown in Figure 32. The 0.1- μ F bypass capacitor supplies the momentary bursts of extra current required from the supply when the device is converting. Place the bypass capacitor as close to the power-supply pin of the device as possible using low-impedance connections. Use multilayer ceramic chip capacitors (MLCCs) that offer low equivalent series resistance (ESR) and inductance (ESL) characteristics for power-supply decoupling purposes. For very sensitive systems, or for systems in harsh noise environments, avoid the use of vias for connecting the capacitors to the device pins for better noise immunity. The use of multiple vias in parallel lowers the overall inductance, and is beneficial for connections to ground planes.

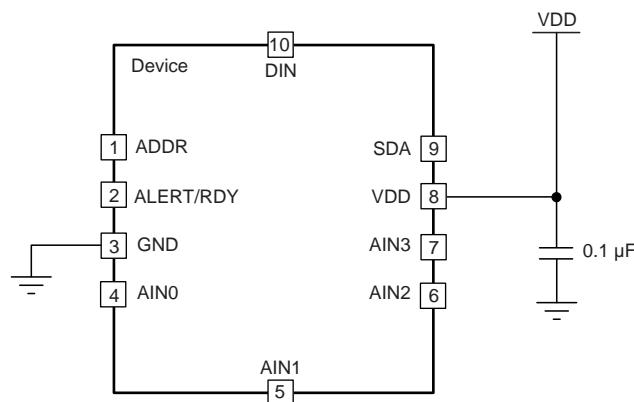

Figure 32. ADS1015 Power-Supply Decoupling

11 Layout

11.1 Layout Guidelines

Employ best design practices when laying out a printed-circuit board (PCB) for both analog and digital components. For optimal performance, separate the analog components [such as ADCs, amplifiers, references, digital-to-analog converters (DACs), and analog MUXs] from digital components [such as microcontrollers, complex programmable logic devices (CPLDs), field-programmable gate arrays (FPGAs), radio frequency (RF) transceivers, universal serial bus (USB) transceivers, and switching regulators]. An example of good component placement is shown in Figure 33. Although Figure 33 provides a good example of component placement, the best placement for each application is unique to the geometries, components, and PCB fabrication capabilities employed. That is, there is no single layout that is perfect for every design and careful consideration must always be used when designing with any analog component.

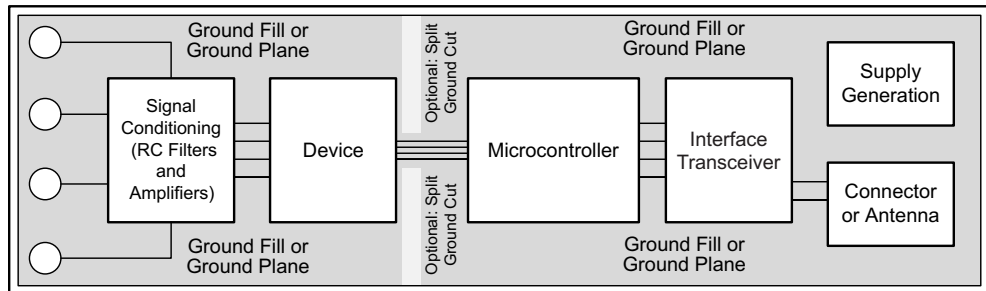

Figure 33. System Component Placement

The following outlines some basic recommendations for the layout of the ADS101x to get the best possible performance of the ADC. A good design can be ruined with a bad circuit layout.

- Separate analog and digital signals. To start, partition the board into analog and digital sections where the layout permits. Route digital lines away from analog lines. This prevents digital noise from coupling back into analog signals.
- Fill void areas on signal layers with ground fill.
- Provide good ground return paths. Signal return currents flow on the path of least impedance. If the ground plane is cut or has other traces that block the current from flowing right next to the signal trace, it has to find another path to return to the source and complete the circuit. If it is forced into a larger path, it increases the chance that the signal radiates. Sensitive signals are more susceptible to EMI interference.
- Use bypass capacitors on supplies to reduce high-frequency noise. Do not place vias between bypass capacitors and the active device. Placing the bypass capacitors on the same layer as close to the active device yields the best results.
- Consider the resistance and inductance of the routing. Often, traces for the inputs have resistances that react with the input bias current and cause an added error voltage. Reduce the loop area enclosed by the source signal and the return current in order to reduce the inductance in the path. Reduce the inductance to reduce the EMI pickup, and reduce the high frequency impedance seen by the device.
- Differential inputs must be matched for both the inputs going to the measurement source.
- Analog inputs with differential connections must have a capacitor placed differentially across the inputs. Best input combinations for differential measurements use adjacent analog input lines such as AIN0, AIN1 and AIN2, AIN3. The differential capacitors must be of high quality. The best ceramic chip capacitors are C0G (NPO), which have stable properties and low-noise characteristics.

11.2 Layout Example

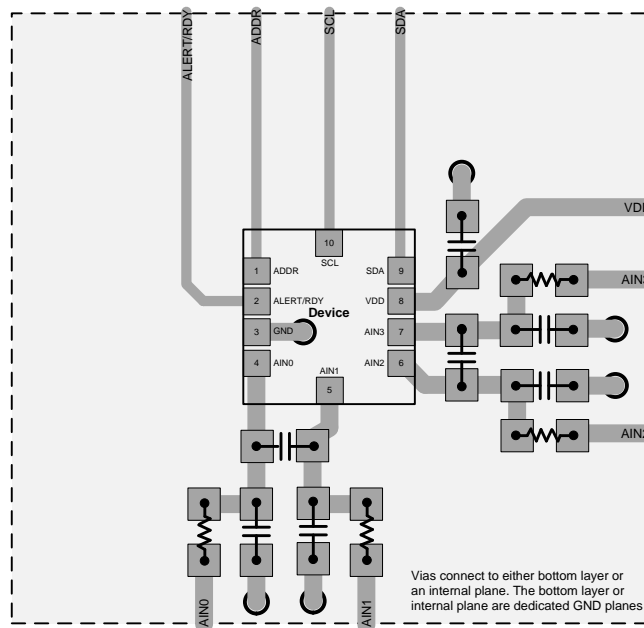

Figure 34. ADS1015 X2QFN Package

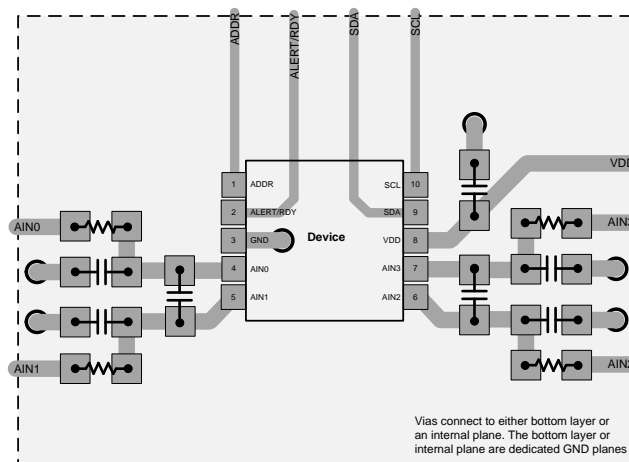

Figure 35. ADS1015 VSSOP Package

12 Device and Documentation Support

12.1 Documentation Support

12.1.1 Related Documentation

For related documentation see the following:

- [OPAx333 1.8-V, microPower, CMOS Operational Amplifiers, Zero-Drift Series](#) (SBOS351)
- [MSP430F20x1, MSP430F20x2, MSP430F20x3 Mixed Signal Microcontroller](#) (SLAS491)
- [TIDA-00824 Human Skin Temperature Sensing for Wearable Applications Reference Design](#) (TIDUAY7)

12.2 Related Links

The following table lists quick access links. Categories include technical documents, support and community resources, tools and software, and quick access to sample or buy.

Table 11. Related Links

PARTS	PRODUCT FOLDER	SAMPLE & BUY	TECHNICAL DOCUMENTS	TOOLS & SOFTWARE	SUPPORT & COMMUNITY
ADS1013	Click here	Click here	Click here	Click here	Click here
ADS1014	Click here	Click here	Click here	Click here	Click here
ADS1015	Click here	Click here	Click here	Click here	Click here

12.3 Receiving Notification of Documentation Updates

To receive notification of documentation updates, navigate to the device product folder on ti.com. In the upper right corner, click on *Alert me* to register and receive a weekly digest of any product information that has changed. For change details, review the revision history included in any revised document.

12.4 Community Resources

The following links connect to TI community resources. Linked contents are provided "AS IS" by the respective contributors. They do not constitute TI specifications and do not necessarily reflect TI's views; see TI's [Terms of Use](#).

TI E2E™ Online Community *TI's Engineer-to-Engineer (E2E) Community*. Created to foster collaboration among engineers. At e2e.ti.com, you can ask questions, share knowledge, explore ideas and help solve problems with fellow engineers.

Design Support *TI's Design Support* Quickly find helpful E2E forums along with design support tools and contact information for technical support.

12.5 Trademarks

E2E is a trademark of Texas Instruments.
All other trademarks are the property of their respective owners.

12.6 Electrostatic Discharge Caution



This integrated circuit can be damaged by ESD. Texas Instruments recommends that all integrated circuits be handled with appropriate precautions. Failure to observe proper handling and installation procedures can cause damage.

ESD damage can range from subtle performance degradation to complete device failure. Precision integrated circuits may be more susceptible to damage because very small parametric changes could cause the device not to meet its published specifications.

12.7 Glossary

SLYZ022 — *TI Glossary*.

This glossary lists and explains terms, acronyms, and definitions.

13 Mechanical, Packaging, and Orderable Information

The following pages include mechanical, packaging, and orderable information. This information is the most current data available for the designated devices. This data is subject to change without notice and revision of this document. For browser-based versions of this data sheet, refer to the left-hand navigation.

PACKAGING INFORMATION

Orderable Device	Status (1)	Package Type	Package Drawing	Pins	Package Qty	Eco Plan (2)	Lead finish/ Ball material (6)	MSL Peak Temp (3)	Op Temp (°C)	Device Marking (4/5)	Samples
ADS1013IDGSR	ACTIVE	VSSOP	DGS	10	2500	RoHS & Green	NIPDAU	Level-2-260C-1 YEAR	-40 to 125	BRMI	Samples
ADS1013IDGST	ACTIVE	VSSOP	DGS	10	250	RoHS & Green	NIPDAU	Level-2-260C-1 YEAR	-40 to 125	BRMI	Samples
ADS1013IRUGR	ACTIVE	X2QFN	RUG	10	3000	RoHS & Green	NIPDAU	Level-1-260C-UNLIM	-40 to 125	N9J	Samples
ADS1013IRUGT	ACTIVE	X2QFN	RUG	10	250	RoHS & Green	NIPDAU	Level-1-260C-UNLIM	-40 to 125	N9J	Samples
ADS1014IDGSR	ACTIVE	VSSOP	DGS	10	2500	RoHS & Green	NIPDAU	Level-2-260C-1 YEAR	-40 to 125	BRQI	Samples
ADS1014IDGST	ACTIVE	VSSOP	DGS	10	250	RoHS & Green	NIPDAU	Level-2-260C-1 YEAR	-40 to 125	BRQI	Samples
ADS1014IRUGR	ACTIVE	X2QFN	RUG	10	3000	RoHS & Green	NIPDAU	Level-1-260C-UNLIM	-40 to 125	N8J	Samples
ADS1014IRUGT	ACTIVE	X2QFN	RUG	10	250	RoHS & Green	NIPDAU	Level-1-260C-UNLIM	-40 to 125	N8J	Samples
ADS1015IDGSR	ACTIVE	VSSOP	DGS	10	2500	RoHS & Green	NIPDAU	Level-2-260C-1 YEAR	-40 to 125	BRPI	Samples
ADS1015IDGST	ACTIVE	VSSOP	DGS	10	250	RoHS & Green	NIPDAU	Level-2-260C-1 YEAR	-40 to 125	BRPI	Samples
ADS1015IRUGR	ACTIVE	X2QFN	RUG	10	3000	RoHS & Green	NIPDAU	Level-1-260C-UNLIM	-40 to 125	N7J	Samples
ADS1015IRUGT	ACTIVE	X2QFN	RUG	10	250	RoHS & Green	NIPDAU	Level-1-260C-UNLIM	-40 to 125	N7J	Samples

(1) The marketing status values are defined as follows:

ACTIVE: Product device recommended for new designs.

LIFEBUY: TI has announced that the device will be discontinued, and a lifetime-buy period is in effect.

NRND: Not recommended for new designs. Device is in production to support existing customers, but TI does not recommend using this part in a new design.

PREVIEW: Device has been announced but is not in production. Samples may or may not be available.

OBSOLETE: TI has discontinued the production of the device.

(2) **RoHS:** TI defines "RoHS" to mean semiconductor products that are compliant with the current EU RoHS requirements for all 10 RoHS substances, including the requirement that RoHS substance do not exceed 0.1% by weight in homogeneous materials. Where designed to be soldered at high temperatures, "RoHS" products are suitable for use in specified lead-free processes. TI may reference these types of products as "Pb-Free".

RoHS Exempt: TI defines "RoHS Exempt" to mean products that contain lead but are compliant with EU RoHS pursuant to a specific EU RoHS exemption.

Green: TI defines "Green" to mean the content of Chlorine (Cl) and Bromine (Br) based flame retardants meet JS709B low halogen requirements of <=1000ppm threshold. Antimony trioxide based flame retardants must also meet the <=1000ppm threshold requirement.

- (3) MSL, Peak Temp. - The Moisture Sensitivity Level rating according to the JEDEC industry standard classifications, and peak solder temperature.
- (4) There may be additional marking, which relates to the logo, the lot trace code information, or the environmental category on the device.
- (5) Multiple Device Markings will be inside parentheses. Only one Device Marking contained in parentheses and separated by a "-" will appear on a device. If a line is indented then it is a continuation of the previous line and the two combined represent the entire Device Marking for that device.
- (6) Lead finish/Ball material - Orderable Devices may have multiple material finish options. Finish options are separated by a vertical ruled line. Lead finish/Ball material values may wrap to two lines if the finish value exceeds the maximum column width.

Important Information and Disclaimer:The information provided on this page represents TI's knowledge and belief as of the date that it is provided. TI bases its knowledge and belief on information provided by third parties, and makes no representation or warranty as to the accuracy of such information. Efforts are underway to better integrate information from third parties. TI has taken and continues to take reasonable steps to provide representative and accurate information but may not have conducted destructive testing or chemical analysis on incoming materials and chemicals. TI and TI suppliers consider certain information to be proprietary, and thus CAS numbers and other limited information may not be available for release.

In no event shall TI's liability arising out of such information exceed the total purchase price of the TI part(s) at issue in this document sold by TI to Customer on an annual basis.

OTHER QUALIFIED VERSIONS OF ADS1013, ADS1014, ADS1015 :

- Automotive : [ADS1013-Q1](#), [ADS1014-Q1](#), [ADS1015-Q1](#)

NOTE: Qualified Version Definitions:

- Automotive - Q100 devices qualified for high-reliability automotive applications targeting zero defects

TAPE AND REEL INFORMATION

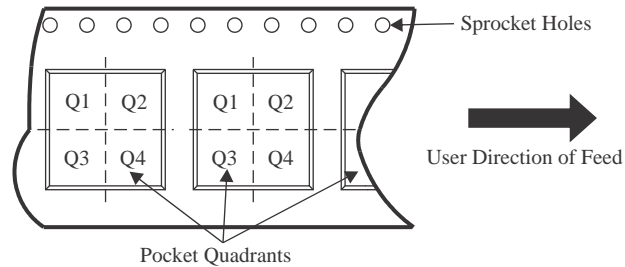
QUADRANT ASSIGNMENTS FOR PIN 1 ORIENTATION IN TAPE

*All dimensions are nominal

Device	Package Type	Package Drawing	Pins	SPQ	Reel Diameter (mm)	Reel Width W1 (mm)	A0 (mm)	B0 (mm)	K0 (mm)	P1 (mm)	W (mm)	Pin1 Quadrant
ADS1013IDGSR	VSSOP	DGS	10	2500	330.0	12.4	5.3	3.3	1.3	8.0	12.0	Q1
ADS1013IDGST	VSSOP	DGS	10	250	180.0	12.4	5.3	3.3	1.3	8.0	12.0	Q1
ADS1013IRUGR	X2QFN	RUG	10	3000	180.0	8.4	1.75	2.25	0.55	4.0	8.0	Q1
ADS1013IRUGT	X2QFN	RUG	10	250	180.0	8.4	1.75	2.25	0.55	4.0	8.0	Q1
ADS1014IDGSR	VSSOP	DGS	10	2500	330.0	12.4	5.3	3.3	1.3	8.0	12.0	Q1
ADS1014IDGST	VSSOP	DGS	10	250	180.0	12.4	5.3	3.3	1.3	8.0	12.0	Q1
ADS1014IRUGR	X2QFN	RUG	10	3000	180.0	8.4	1.75	2.25	0.55	4.0	8.0	Q1
ADS1014IRUGT	X2QFN	RUG	10	250	180.0	8.4	1.75	2.25	0.55	4.0	8.0	Q1
ADS1015IDGSR	VSSOP	DGS	10	2500	330.0	12.4	5.3	3.3	1.3	8.0	12.0	Q1
ADS1015IDGST	VSSOP	DGS	10	250	180.0	12.4	5.3	3.3	1.3	8.0	12.0	Q1
ADS1015IRUGR	X2QFN	RUG	10	3000	180.0	8.4	1.75	2.25	0.55	4.0	8.0	Q1
ADS1015IRUGT	X2QFN	RUG	10	250	180.0	8.4	1.75	2.25	0.55	4.0	8.0	Q1

TAPE AND REEL BOX DIMENSIONS

*All dimensions are nominal

Device	Package Type	Package Drawing	Pins	SPQ	Length (mm)	Width (mm)	Height (mm)
ADS1013IDGSR	VSSOP	DGS	10	2500	367.0	367.0	38.0
ADS1013IDGST	VSSOP	DGS	10	250	213.0	191.0	35.0
ADS1013IRUGR	X2QFN	RUG	10	3000	210.0	185.0	35.0
ADS1013IRUGT	X2QFN	RUG	10	250	210.0	185.0	35.0
ADS1014IDGSR	VSSOP	DGS	10	2500	367.0	367.0	38.0
ADS1014IDGST	VSSOP	DGS	10	250	213.0	191.0	35.0
ADS1014IRUGR	X2QFN	RUG	10	3000	210.0	185.0	35.0
ADS1014IRUGT	X2QFN	RUG	10	250	210.0	185.0	35.0
ADS1015IDGSR	VSSOP	DGS	10	2500	367.0	367.0	38.0
ADS1015IDGST	VSSOP	DGS	10	250	213.0	191.0	35.0
ADS1015IRUGR	X2QFN	RUG	10	3000	210.0	185.0	35.0
ADS1015IRUGT	X2QFN	RUG	10	250	210.0	185.0	35.0

DGS0010A



PACKAGE OUTLINE

VSSOP - 1.1 mm max height

SMALL OUTLINE PACKAGE



4221984/A 05/2015

NOTES:

1. All linear dimensions are in millimeters. Any dimensions in parenthesis are for reference only. Dimensioning and tolerancing per ASME Y14.5M.
2. This drawing is subject to change without notice.
3. This dimension does not include mold flash, protrusions, or gate burrs. Mold flash, protrusions, or gate burrs shall not exceed 0.15 mm per side.
4. This dimension does not include interlead flash. Interlead flash shall not exceed 0.25 mm per side.
5. Reference JEDEC registration MO-187, variation BA.

EXAMPLE BOARD LAYOUT

DGS0010A

VSSOP - 1.1 mm max height

SMALL OUTLINE PACKAGE



LAND PATTERN EXAMPLE
SCALE:10X



SOLDER MASK DETAILS
NOT TO SCALE

4221984/A 05/2015

NOTES: (continued)

- 6. Publication IPC-7351 may have alternate designs.
- 7. Solder mask tolerances between and around signal pads can vary based on board fabrication site.

EXAMPLE STENCIL DESIGN

DGS0010A

VSSOP - 1.1 mm max height

SMALL OUTLINE PACKAGE



SOLDER PASTE EXAMPLE
BASED ON 0.125 mm THICK STENCIL
SCALE:10X

4221984/A 05/2015

NOTES: (continued)

8. Laser cutting apertures with trapezoidal walls and rounded corners may offer better paste release. IPC-7525 may have alternate design recommendations.
9. Board assembly site may have different recommendations for stencil design.

RUG (R-PQFP-N10)

PLASTIC QUAD FLATPACK

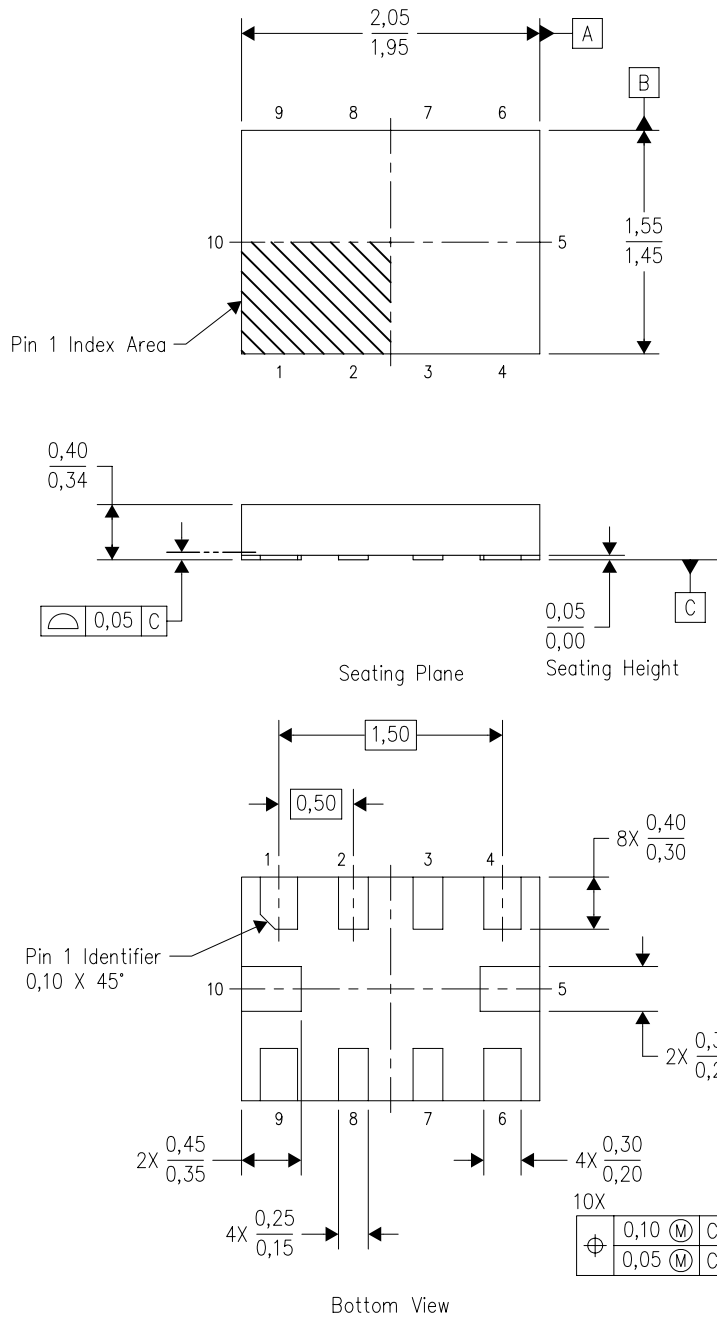

4208528-3/B 04/2008

- NOTES:
- A. All linear dimensions are in millimeters. Dimensioning and tolerancing per ASME Y14.5M-1994.
 - B. This drawing is subject to change without notice.
 - C. QFN (Quad Flatpack No-Lead) package configuration.
 - D. This package complies to JEDEC MO-288 variation X2EFD.

IMPORTANT NOTICE AND DISCLAIMER

TI PROVIDES TECHNICAL AND RELIABILITY DATA (INCLUDING DATA SHEETS), DESIGN RESOURCES (INCLUDING REFERENCE DESIGNS), APPLICATION OR OTHER DESIGN ADVICE, WEB TOOLS, SAFETY INFORMATION, AND OTHER RESOURCES "AS IS" AND WITH ALL FAULTS, AND DISCLAIMS ALL WARRANTIES, EXPRESS AND IMPLIED, INCLUDING WITHOUT LIMITATION ANY IMPLIED WARRANTIES OF MERCHANTABILITY, FITNESS FOR A PARTICULAR PURPOSE OR NON-INFRINGEMENT OF THIRD PARTY INTELLECTUAL PROPERTY RIGHTS.

These resources are intended for skilled developers designing with TI products. You are solely responsible for (1) selecting the appropriate TI products for your application, (2) designing, validating and testing your application, and (3) ensuring your application meets applicable standards, and any other safety, security, regulatory or other requirements.

These resources are subject to change without notice. TI grants you permission to use these resources only for development of an application that uses the TI products described in the resource. Other reproduction and display of these resources is prohibited. No license is granted to any other TI intellectual property right or to any third party intellectual property right. TI disclaims responsibility for, and you will fully indemnify TI and its representatives against, any claims, damages, costs, losses, and liabilities arising out of your use of these resources.

TI's products are provided subject to [TI's Terms of Sale](#) or other applicable terms available either on [ti.com](https://www.ti.com) or provided in conjunction with such TI products. TI's provision of these resources does not expand or otherwise alter TI's applicable warranties or warranty disclaimers for TI products.

TI objects to and rejects any additional or different terms you may have proposed.

Mailing Address: Texas Instruments, Post Office Box 655303, Dallas, Texas 75265
Copyright © 2024, Texas Instruments Incorporated

Looking for pricing, stock, or lifecycle information?

Click below to explore more details on WIN SOURCE:

 [View ADS1014IDGST](#) on WIN SOURCE

 [Texas Instruments](#) Information

Optimize Your Supply Chain with WIN SOURCE Solutions

-  Global Sourcing Solution
-  Obsolete Management
-  Cost Control Management
-  Shortage Management
-  Alternative Solution
-  Excess Inventory Management