



# THE DATASHEET OF CDCE421RGET



## Fully Integrated Wide-Range, Low-Jitter, Crystal-Oscillator Clock Generator

### FEATURES

- Single 3.3-V Supply
- High-Performance Clock Generator Incorporating Crystal-Oscillator Circuitry With Integrated Frequency Synthesizer
- Low-Output Jitter: As Low as 380 fs (rms Integrated Between 10 kHz–20 MHz)
- Low Phase Noise at High Frequency: at 708 MHz it is less than  $-109$  dBc/Hz at 10-kHz and  $-146$  dBc/Hz at 10-MHz Offset from the Carrier
- Supports Crystal Frequencies Between 27.35 MHz to 38.33 MHz
- Output Frequency Ranges from 10.9 MHz up to 766.7 MHz and from 875.2 MHz up to 1175 MHz
- Low-Voltage Differential Signaling (LVDS) Output, 100- $\Omega$  Differential Off-Chip Termination, 10.9-MHz to 400-MHz Frequency Range
- Differential Low-Voltage Positive Emitter-Coupled Logic (LVPECL) Output, 10.9-MHz to 1.175-GHz Frequency Range
- Two Fully Integrated Voltage-Controlled Oscillators (VCOs) Support Wide Output Frequency Range
- Fully Integrated Programmable Loop Filter
- Typical Power Consumption: 274 mW in LVDS Mode and 250 mW in LVPECL Mode
- Chip-Enable Control Pin
- Simple Serial Interface Allows Programming After Manufacturing
- Integrated On-Chip Nonvolatile Memory (EEPROM) to Store Settings Without the Need to Apply High Voltage to the Device
- QFN24 Package
- ESD Protection Exceeds 2 kV HBM
- Industrial Temperature Range:  $-40^{\circ}\text{C}$  to  $+85^{\circ}\text{C}$

### APPLICATIONS

- Low-Cost, High-Frequency Crystal Oscillator

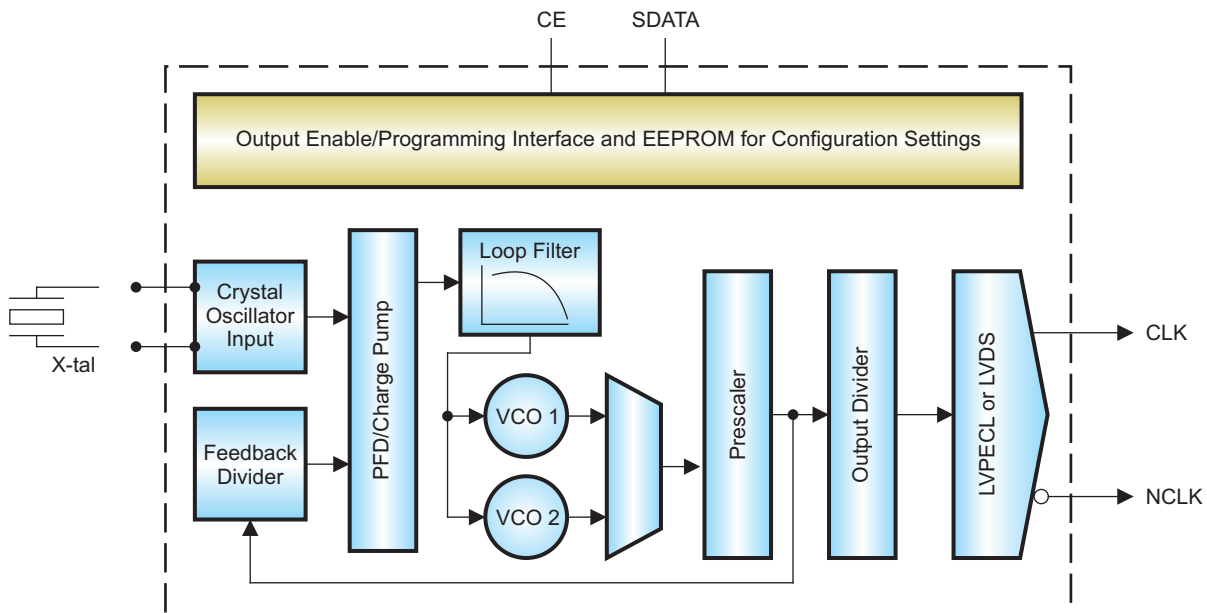

B0216-01



Please be aware that an important notice concerning availability, standard warranty, and use in critical applications of Texas Instruments semiconductor products and disclaimers thereto appears at the end of this data sheet.

All trademarks are the property of their respective owners.



These devices have limited built-in ESD protection. The leads should be shorted together or the device placed in conductive foam during storage or handling to prevent electrostatic damage to the MOS gates.

## DESCRIPTION

The CDCE421 is a high-performance, low-phase-noise clock generator. It has two fully integrated, low-noise, LC-based voltage controlled oscillators (VCOs) that operate in the 1.750-GHz to 2.350-GHz frequency range. It has an integrated crystal oscillator that operates in conjunction with an external AT-cut crystal to produce a stable frequency reference for the PLL-based frequency synthesizer.

The output frequency ( $f_{out}$ ) is proportional to the frequency of the input crystal ( $f_{xtal}$ ). The prescaler divider, feedback divider, output divider, and VCO selection are what set ( $f_{out}$ ) with respect to ( $f_{xtal}$ ). For a desired frequency ( $f_{out}$ ), look in [Table 1](#) and find the corresponding settings in the same row. Use [Equation 1](#) to calculate the exact crystal oscillator frequency needed for the desired output.

$$f_{xtal} = \left( \frac{\text{OutputDivider}}{\text{FeedbackDivider}} \right) \times f_{out} \quad (1)$$

Output divider<sup>(1)</sup> = 1, 2, 4, 8, 16, or 32

Feedback divider<sup>(2)</sup> = 12, 16, 20, or 32

<sup>(1)</sup>Output divider and feedback divider should be from the same row in [Table 1](#).

<sup>(2)</sup>Feedback divider is set automatically with respect to the prescaler setting in [Table 1](#).

A high-level block diagram of the CDCE421 is shown in [Figure 1](#).

The CDCE421 supports one differential LVDS clock output or one differential LVPECL output.

All device settings are programmable through a Texas Instruments proprietary simple serial interface.

The device operates in a 3.3-V supply environment and is characterized for operation from  $-40^{\circ}\text{C}$  to  $+85^{\circ}\text{C}$ .

The CDCE421 is available in a QFN-24 package.

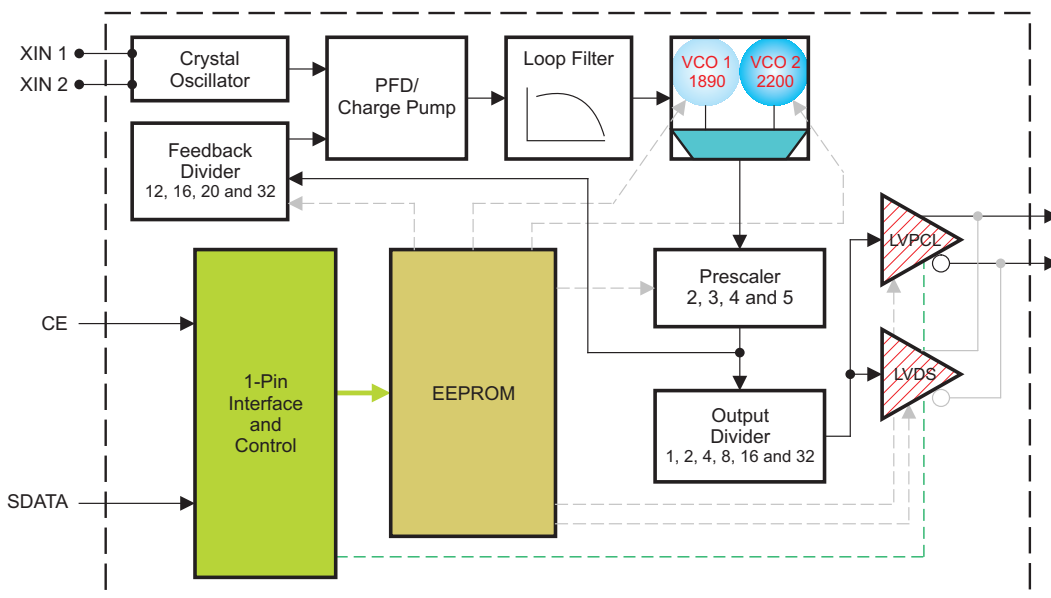

B0217-01

**Figure 1. High-Level Block Diagram of the CDCE421**

In the CDCE421, the feedback divider is set automatically with respect to the prescaler setting. The product of the prescaler and the feedback divider will be either 60 or 64, as shown in [Table 1](#), to keep the control loop stable.

**DEVICE SETUP AND CONFIGURATION**
**Table 1. Crystal Frequency Selection and Device Settings**

DESIRED OUTPUT FREQUENCY (MHz)		REQUIRED INPUT CRYSTAL FREQUENCY (MHz)		VCO SELECTION	OUTPUT DIVIDER	PRESCALER SETTING	FEEDBACK DIVIDER <sup>(1)</sup>
From	To	From	To				
1020.0	1175.0	31.875	36.719	VCO 2	1	2	32
<b>875.2</b> <sup>(2)</sup>	1020.0	27.351	31.875	VCO 1	1	2	32
650.0	<b>766.7</b> <sup>(2)</sup>	32.500	38.333	VCO 2	1	3	20
583.5	650.0	29.174	32.500	VCO 1	1	3	20
510.0	587.5	31.875	36.719	VCO 2	1	4	16
437.6	510.0	27.351	31.875	VCO 1	1	4	16
408.0	460.0	34.000	38.333	VCO 2	1	5	12
350.1	408.0	29.174	34.000	VCO 1	1	5	12
340.0	383.3	34.000	38.333	VCO 2	2	3	20
291.7	340.0	29.174	34.000	VCO 1	2	3	20
255.0	293.8	31.875	36.719	VCO 2	2	4	16
218.8	255.0	27.351	31.875	VCO 1	2	4	16
204.0	230.0	34.000	38.333	VCO 2	2	5	12
175.0	204.0	29.174	34.000	VCO 1	2	5	12
170.0	191.7	34.000	38.333	VCO 2	4	3	20
145.9	170.0	29.174	34.000	VCO 1	4	3	20
127.5	146.9	31.875	36.719	VCO 2	4	4	16
109.4	127.5	27.351	31.875	VCO 1	4	4	16
102.0	115.0	34.000	38.333	VCO 2	4	5	12
87.5	102.0	29.174	34.000	VCO 1	4	5	12
85.0	95.8	34.000	38.333	VCO 2	8	3	20
72.9	85.0	29.174	34.000	VCO 1	8	3	20
63.8	73.4	31.875	36.719	VCO 2	8	4	16
54.7	63.8	27.351	31.875	VCO 1	8	4	16
51.0	57.5	34.000	38.333	VCO 2	8	5	12
43.8	51.0	29.174	34.000	VCO 1	8	5	12
42.5	47.9	34.000	38.333	VCO 2	16	3	20
36.5	42.5	29.174	34.000	VCO 1	16	3	20
31.9	36.7	31.875	36.719	VCO 2	16	4	16
27.4	31.9	27.351	31.875	VCO 1	16	4	16
25.5	28.8	34.000	38.333	VCO 2	16	5	12
21.9	25.5	29.174	34.000	VCO 1	16	5	12
21.3	24.0	34.000	38.333	VCO 2	32	3	20
18.2	21.3	29.174	34.000	VCO 1	32	3	20
15.9	18.4	31.875	36.719	VCO 2	32	4	16
13.7	15.9	27.351	31.875	VCO 1	32	4	16
12.8	14.4	34.000	38.333	VCO 2	32	5	12
10.9	12.8	29.174	34.000	VCO 1	32	5	12

(1) The feedback divider is set automatically with respect to the prescaler setting.

(2) Discontinuity in frequency range.

## DEVICE SETUP EXAMPLE

The following example illustrates the procedure to calculate the required AT-cut crystal frequency needed to generate a desired output frequency.

Assuming the requirement to generate an output frequency of 622.08 MHz, [Table 1](#) shows that the desired output frequency lies between 583.5 MHz and 680 MHz.

DESIRED OUTPUT FREQUENCY (MHz)		REQUIRED INPUT CRYSTAL FREQUENCY (MHz)		VCO SELECTION	OUTPUT DIVIDER	PRESCALER SETTING	FEEDBACK DIVIDER <sup>(1)</sup>
From	To	From	To				
650.0	<b>766.7</b>	32.500	38.333	VCO 2	1	3	20
583.5	650.0	29.174	32.500	VCO 1	1	3	20
510.0	587.5	31.875	36.719	VCO 2	1	4	16

(1) The feedback divider is set automatically with respect to the prescaler setting.

So this means that the device must be configured with:

VCO = **VCO 1**

Output divider = **1**

Prescaler setting = **3**

To determine the correct crystal frequency needed to get 622.08 MHz with these settings, substitute values into [Equation 1](#).

$$f_{\text{xtal}} = \left( \frac{\text{OutputDivider}}{\text{FeedbackDivider}} \right) \times f_{\text{out}} \quad f_{\text{xtal}} = \left( \frac{1}{20} \right) \times 622.08 = 31.154 \text{ MHz} \quad (2)$$

The AT-cut frequency should be **31.154 MHz** (between 29.174 MHz and 32.500 MHz, as shown in [Table 1](#)).

## SERIAL INTERFACE AND CONTROL

The CDCE421 uses a unique Texas Instruments proprietary interface protocol that can be configured and programmed via a single input pin to the device. The architecture enables only writing to the device from this input pin. Reading the content of a register can be achieved by sending a read command on the input pin and monitoring the output pins (LVDS or LVPECL). In cases where the output pins cannot be used to read the content, the software controlling the interface must account for what is written to the EEPROM and when it is programmed. Monitoring the outputs verifies the programming modes, and cycling power on the device verifies that the EEPROM is holding the proper configuration.

The CDCE421 can be configured and programmed via the SDATA input pin. For this purpose, a square-wave programming sequence must be written to the device as described in the following section. During the EEPROM programming phase, the device requires a stable  $V_{CC}$  of 3 V to 3.6 V for secure writing of the EEPROM cells. After each *Write to WordX*, the written data are latched, made effective, and offer look-ahead before the actual data are stored into the EEPROM.

The following table summarizes all valid programming commands.

SDATA	FUNCTION
00 1100	Enter <b>Programming Mode</b> (State 1 → State 2); bits must be sent in the specified order with the specified timing. Otherwise, a <i>time-out</i> occurs.
11 1011	Enter <b>Register Read Back Mode</b> ; bits must be sent in the specified order with the specified timing. Otherwise, a <i>time-out</i> occurs.
000 xxxx xxxx	<b>Write to Word0</b> (State 2) <sup>(1)</sup> <sup>(2)</sup> <sup>(3)</sup>
100 xxxx xxxx	<b>Write to Word1</b> (State 2) <sup>(1)</sup> <sup>(2)</sup> <sup>(3)</sup>
010 xxxx xxxx	<b>Write to Word2</b> (State 2) <sup>(1)</sup> <sup>(2)</sup> <sup>(3)</sup>
110 xxxx xxxx	<b>Write to Word3</b> (State 2) <sup>(1)</sup> <sup>(2)</sup> <sup>(3)</sup>

(1) Each rising edge causes a bit to be latched.

(2) Between the bits, some longer time delays can occur, but this has no effect on the data.

(3) A *Write to WordX* is expected to be 10 bits long. After the 10th bit, the respective word is latched and its effect can be observed as *look-ahead* function.

SDATA	FUNCTION
001 xxxx xxxx	Write to Word4 (State 2) <sup>(1)</sup> (2) (3)
101 xxxx xxxx	Write to Word5 (State 2) <sup>(1)</sup> (2) (3)
111 xxxx xxxx	<b>State machine jump:</b> All other patterns not defined as follows cause an <i>exit to normal mode</i> .
111 1111 0000	Jump: <b>Enter EEPROM programming without EEPROM lock</b> (State 2 → State 3)
111 0101 0101	Jump: <b>Enter EEPROM programming with EEPROM lock</b> (State 2 → State 4)
111 0000 0000	Jump: <b>Exit EEPROM programming</b> (State 3 or State 4 → State 1)

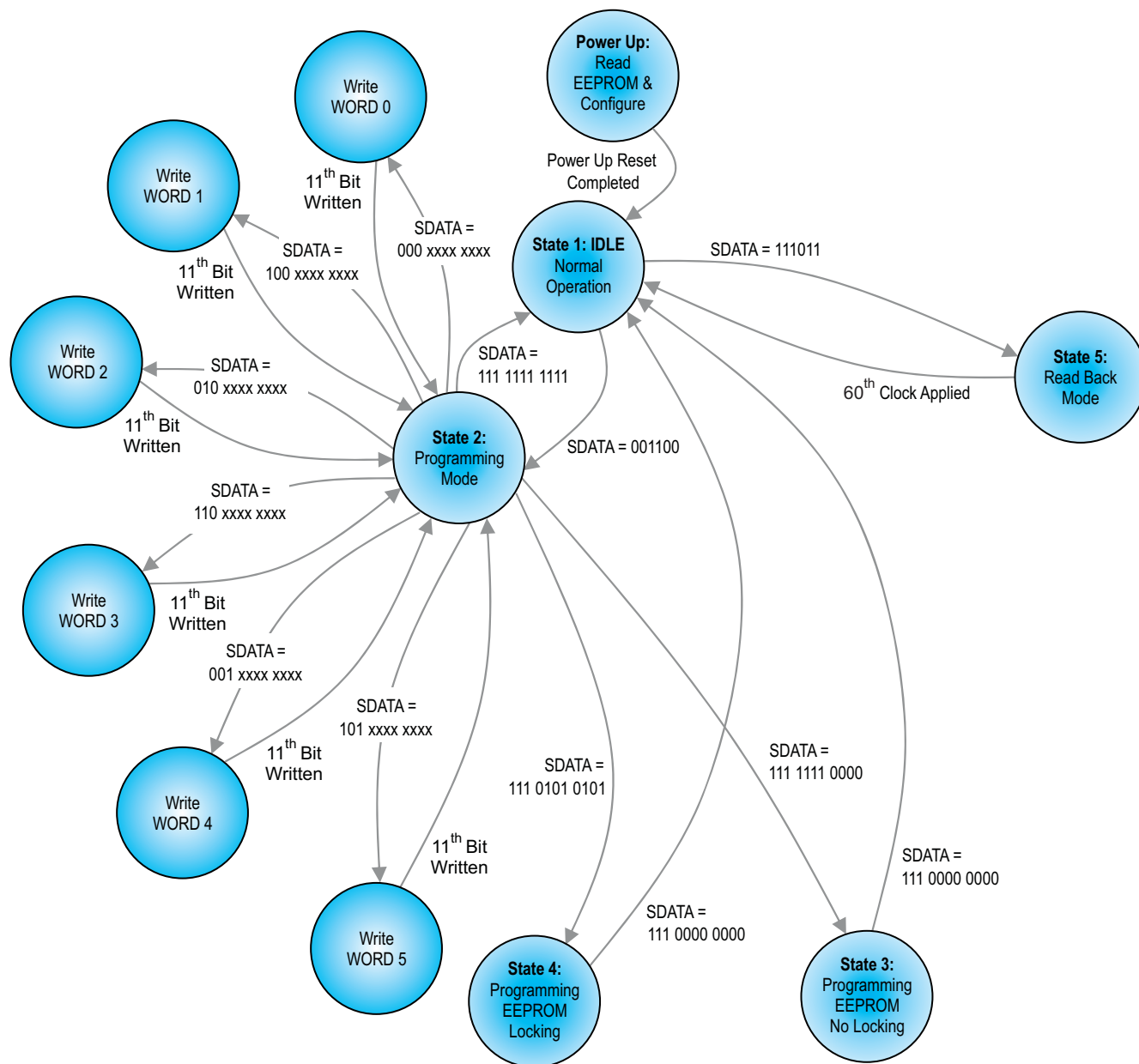

F0016-02

NOTE: In States 2, 3, 4, and 5, the signal pin CE is disregarded and has no influence on power down.

Figure 2. State Flow-Diagram of Single-Pin Interface

### Enter Programming Mode

Figure 3 shows the timing behavior of data to be written into SDATA. The sequence shown is 00 1100. If the high period is as short as  $t_1$ , this is interpreted as 0. If the high period is as long as  $t_3$ , this is interpreted as a 1. This behavior is achieved by shifting the incoming signal SDATA by time  $t_5$  into signal SDATA\_DELAYED. As can be seen in Figure 3, SDATA\_DELAYED can be used to latch (or strobe) SDATA. The timing specifications for  $t_1$ – $t_7$ ,  $t_r$ , and  $t_f$  are shown in Figure 3.

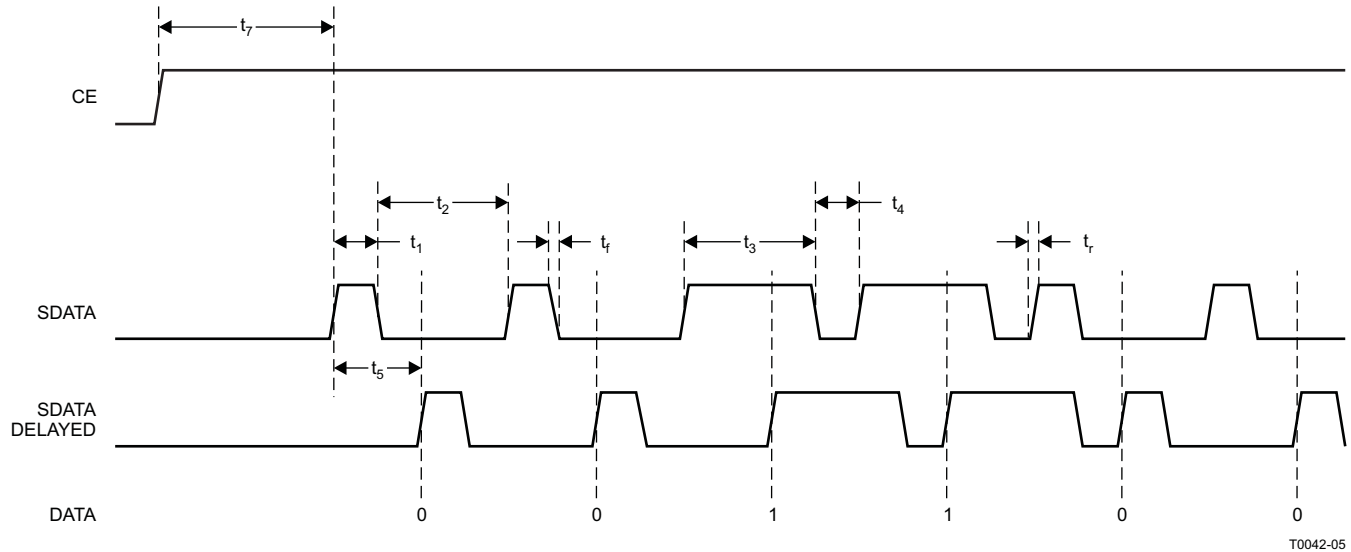

T0042-05

		MIN	TYP	MAX	UNIT
$f_{SDATACLK}$	Repeat frequency of programming	60	70	80	kHz
$t_1$	LOW signal: high-pulse duration		0.2 t		ms
$t_2$	LOW signal: low-pulse duration while entering programming sequence		0.8 t		ms
$t_2$	LOW signal: low-pulse duration while programming bits		0.8 t		ms
$t_3$	HIGH signal: high-pulse duration		0.8 t		ms
$t_4$	HIGH signal: low-pulse duration while entering programming sequence		0.2 t		ms
$t_4$	HIGH signal: low-pulse duration while programming bits		0.2 t		ms
$t_6$	Time-out during <i>Entering Programming Mode</i> and <i>Enter Read Back Mode</i> . High-pulse or low-pulse duration each must be less than this time; otherwise, time-out will result.	16			$\mu$ s
$t_7$	CE-high time before first SDATA can be clocked in	3 t			ms
$t_r$ and $t_f$	Rise Time and Fall Time		2		ns
$t = 1 / f_{SDATACLK}$					

Figure 3. SDATA/CE Timing

### EEPROM PROGRAMMING

Load all the registers in RAM by writing Word0 through Word5, and after going back to State 2, then going to State 3 (programming EEPROM, no locking) or State 4 (programming EEPROM with locking), the contents of Word0–Word5 are saved in the EEPROM. Wait 10 ms in State 3 or State 4 when programming the EEPROM before moving to State 2 (the idle state).

**NOTE:**

When writing to the device for functionality testing and verification via the serial bus, only the RAM is being accessed.

**EXAMPLE: Programming Cycle of Six Words and Programming Into EEPROM**

The following sequence shows how to *enter programming mode* and how the different words can be written. The addressing of Word0 ... Word5 is shown in bold. After the word address, the payload for the respective word is clocked in. In this example, this is followed by a jump from State 2 → State 3 into *enter EEPROM programming with EEPROM lock*. In the EEPROM-programming state, it is necessary to wait at least 10 ms for safe programming. The last command is a jump from State 3 into State 1 (normal operation). Cycle power and verify that the device functions as programmed.

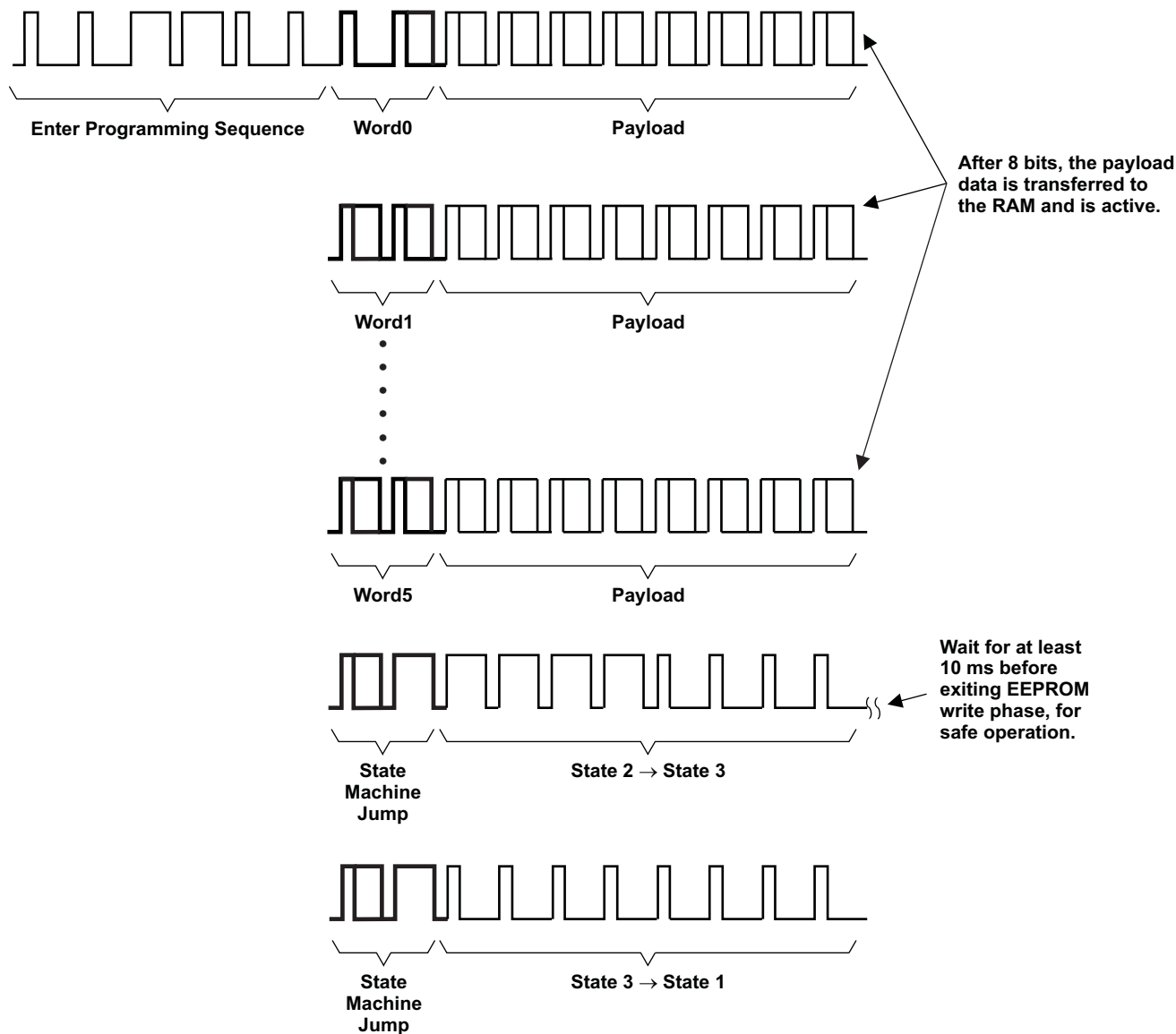
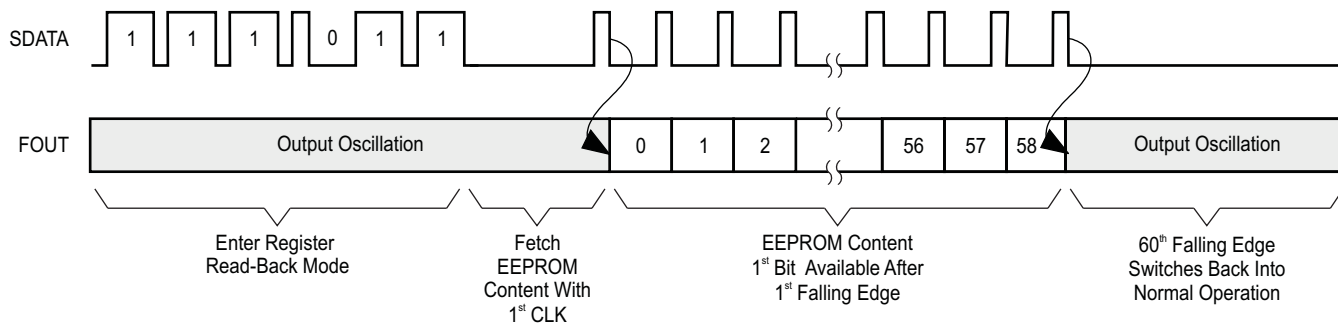

Figure 4. Programming Cycle of Six Words and Programming Into EEPROM

T0043-03

**Enter Register Readback Mode and Related Timing Diagram**

Similar to the *enter programming mode* sequence, the *enter register read back mode* is written into SDATA. After the command has been issued, the SDATA input is reconfigured as clock input. By applying one clock, the EEPROM content is read into shift registers. Now, by further applying clocks at SDATA, the EEPROM content can be clocked out and observed at OUP/OUTN. There are 59 bits to be clocked out. With the 61st rising clock edge, the OUP/OUTN pins are reconfigured back into normal operation.



T0044-03

In the following table, the content of the output bit stream is summarized. Important to notice: bit 0 is clocked out first. The default values in register 0 to register 5 are programmed in the EEPROM.

OUTPUT BIT STREAM	FUNCTION
Bits[0:2]	Revision identifier (MSB first)
Bits[3:8]	VCO calibration word
Bit[9]	EEPROM status: 0 = EEPROM has never been written 1 = EEPROM has been programmed before
Bit[10]	EEPROM lock: 0 = EEPROM can be rewritten 1 = EEPROM is locked, rewriting to the EEPROM is not possible any more
Bits[11:18]	Storage value, Word5 (MSB first)
Bits[19:26]	Storage value, Word4 (MSB first)
Bits[27:34]	Storage value, Word3 (MSB first)
Bits[35:42]	Storage value, Word2 (MSB first)
Bits[43:50]	Storage value, Word1 (MSB first)
Bits[51:58]	Storage value, Word0 (MSB first)

### REGISTER DESCRIPTIONS

Word 0:				
BIT	NAME	DESCRIPTION/FUNCTION	TYPE	DEFAULT VALUE
0	C0	Register selection	W	0
1	C1	Register selection	W	0
2	C2	Register selection	W	0
3	SELVCO	VCO select, 0 = VCO1, 1 = VCO2	W	0
4	SELPRESC	Prescaler setting, bit 0	W	0
5	SELPRESC	Prescaler setting, bit 1	W	1
6	OUTSEL	Output divider select, bit 0	W	1
7	OUTSEL	Output divider select, bit1	W	1
8	OUTSEL	Output divider select, bit 2	W	0
9	DRVSEL	Driver select, 0 = LVDS, 1 = PECL	W	1
10	TITEST0	Reserved	W	1
4	Divide by value (SELPRESC 1, SELPRESC 0)			
5	Divide by 5 = (00), 3 = (01), 4 = (10), 2 = (11)			
6	Output divider (OUTSEL2, OUTSEL1, OUTSEL0)			
7	Divide by 1 = (000), 2 = (001), 4 = (010), 8 = (011), 16 = (100), 32 = (101)			
8				

<b>Word 1:</b>				
<b>BIT</b>	<b>NAME</b>	<b>DESCRIPTION/FUNCTION</b>	<b>TYPE</b>	<b>DEFAULT VALUE</b>
0	C0	Register selection	W	1
1	C1	Register selection	W	0
2	C2	Register selection	W	0
3	LFRCSSEL	Loop filter control settings, bit 0	W	1
4	LFRCSSEL	Loop filter control settings, bit 1	W	1
5	LFRCSSEL	Loop filter control settings, bit 2	W	1
6	LFRCSSEL	Loop filter control settings, bit 3	W	1
7	LFRCSSEL	Loop filter control settings, bit 4	W	1
8	LFRCSSEL	Loop filter control settings, bit 5	W	0
9	LFRCSSEL	Loop filter control settings, bit 6	W	1
10	LFRCSSEL	Loop filter control settings, bit 7	W	0

<b>Word 2:</b>				
<b>BIT</b>	<b>NAME</b>	<b>DESCRIPTION/FUNCTION</b>	<b>TYPE</b>	<b>DEFAULT VALUE</b>
0	C0	Register selection	W	0
1	C1	Register selection	W	1
2	C2	Register selection	W	0
3	LFRCSSEL	Loop filter control settings, bit 8	W	1
4	LFRCSSEL	Loop filter control settings, bit 9	W	1
5	LFRCSSEL	Loop filter control settings, bit 10	W	0
6	LFRCSSEL	Loop filter control settings, bit 11	W	0
7	LFRCSSEL	Loop filter control settings, bit 12	W	0
8	LFRCSSEL	Loop filter control settings, bit 13	W	0
9	LFRCSSEL	Loop filter control settings, bit 14	W	0
10	LFRCSSEL	Loop filter control settings, bit 15	W	0

<b>Word 3:</b>				
<b>BIT</b>	<b>NAME</b>	<b>DESCRIPTION/FUNCTION</b>	<b>TYPE</b>	<b>DEFAULT VALUE</b>
0	C0	Register selection	W	1
1	C1	Register selection	W	1
2	C2	Register selection	W	0
3	LFRCSSEL	Loop filter control settings, bit 16	W	0
4	LFRCSSEL	Loop filter control settings, bit 17	W	0
5	LFRCSSEL	Loop filter control settings, bit 18	W	0
6	ICPSEL	Charge pump current sel, bit 0	W	1
7	ICPSEL	Charge pump current sel, bit 1	W	1
8	ICPSEL	Charge pump current sel, bit 2	W	1
9	ICPSEL	Charge pump current sel, bit 3	W	1
10	TITEST1	Reserved	W	0

<b>Word 4:</b>				
<b>BIT</b>	<b>NAME</b>	<b>DESCRIPTION/FUNCTION</b>	<b>TYPE</b>	<b>DEFAULT VALUE</b>
0	C0	Register selection	W	0
1	C1	Register selection	W	0
2	C2	Register selection	W	1
3	CALWRD	VCO calibration word, bit 0	W	0
4	CALWRD	VCO calibration word, bit 1	W	0
5	CALWRD	VCO calibration word, bit 2	W	0
6	CALWRD	VCO calibration word, bit 3	W	0
7	CALWRD	VCO calibration word, bit 4	W	0
8	CALWRD	VCO calibration word, bit 5	W	0
9	CALOVR	VCO calibration override	W	0
10	ENCAL	Enable VCO calibration	W	1

<b>Word 5:</b>				
<b>BIT</b>	<b>NAME</b>	<b>DESCRIPTION/FUNCTION</b>	<b>TYPE</b>	<b>DEFAULT VALUE</b>
0	C0	Register selection	W	1
1	C1	Register selection	W	0
2	C2	Register selection	W	1
3	TITSTCFG	TI test use, bit 0	W	0
4	TITSTCFG	TI test use, bit 1	W	0
5	TITSTCFG	TI test use, bit 2	W	0
6	TITSTCFG	TI test use, bit 3	W	0
7	Not used		W	0
8	Not used		W	0
9	Not used		W	0
10	Not used		W	0

### PACKAGE (QFN24)

The CDCE421 is available in a QFN 24-pin package. The QFN package footprint is illustrated in Figure 5, as well as the pad locations and numbers.

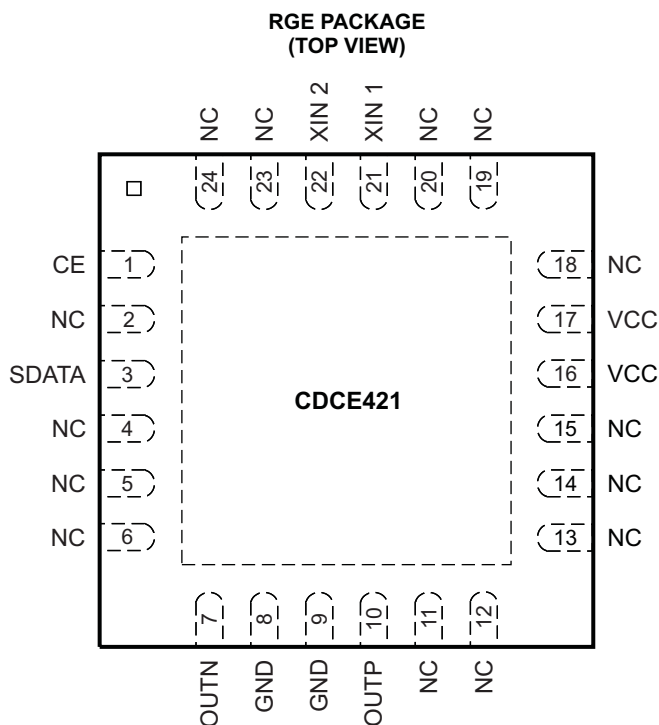

P0024-05

**Figure 5. Pinout of the CDCE421 QFN-24 Package**

### PIN DESCRIPTIONS

Table 2 shows the pin descriptions for the CDCE421 QFN-24 package.

**Table 2. CDCE421 Pin Descriptions**

TERMINAL NAME	TERMINAL NO.	TYPE	ESD PROTECTION	DESCRIPTION
CE	1	I	Y	Chip enable CE = 1: enable the device and the outputs. CE = 0: disable all current sources; in LVDS mode, LVDS <sub>P</sub> = LVDS <sub>N</sub> = Hi-Z; in LVPECL mode, LVPECL <sub>P</sub> = LVPECL <sub>N</sub> = Hi-Z.
GND	8, 9	GND	Y	Ground
No connect	2, 4–6, 11–15, 18–20, 23,24			Do not connect these pins. Leave them floating.
OUTN	7	O	Y	High-speed negative differential LVPECL or LVDS outputs. (Outputs are enabled by CE and selected by the EEPROM configuration registers.)
OUTP	10	O	Y	High-speed positive differential LVPECL or LVDS outputs. (Outputs are enabled by CE and selected by the EEPROM configuration registers.)
SDATA	3	I	Y	Programming pin using TI proprietary interface protocol
VCC	16, 17	Power	Y	3.3-V power supply
XIN 1 XIN 2	21 22	I GND/NC	Y N	In crystal input mode, connect XIN1 to one end of the crystal and XIN2 to the other end of the crystal. In LVCMOS input single-ended driven mode, XIN1 (pin 21) acts as an input reference, and XIN2 should connect to GND or it can be left unconnected.

## OUTPUTS (LVPECL OR LVDS)

The CDCE421 device has two sets of output drivers, LVPECL and LVDS, where the outputs are wire-ORed together. Only one output can be selected at a time; the other goes to the high-impedance state (Hi-Z).

If the device is configured for an LVPECL, the output buffers go to Hi-Z and the termination resistors determine the state of the output (LVPECLP = LVPECLN = Hi-Z) in the device disable mode (CE = L). If the device is configured in LVDS mode, the outputs go to Hi-Z if the device is disabled (CE = L).

## ABSOLUTE MAXIMUM RATINGS<sup>(1)</sup>

Over operating free-air temperature range (unless otherwise noted).

		VALUE	UNIT
V <sub>CC</sub>	Supply voltage <sup>(2)</sup>	–0.5 to 4.6	V
V <sub>I</sub>	Voltage range for all other input pins <sup>(2)</sup>	–0.5 to V <sub>CC</sub> + 0.5	V
I <sub>O</sub>	Output current for LVPECL	–50	mA
	Electrostatic discharge (HBM)	2	kV
T <sub>A</sub>	Characterized free-air temperature range (no airflow)	–40 to +85	°C
T <sub>J</sub>	Maximum junction temperature	+125	°C
T <sub>stg</sub>	Storage temperature range	–65 to +150	°C

- (1) Stresses beyond those listed under *absolute maximum ratings* may cause permanent damage to the device. These are stress ratings only, and functional operation of the device at these or any other conditions beyond those indicated under *recommended operating conditions* is not implied. Exposure to absolute-maximum-rated conditions for extended periods may affect device reliability.
- (2) All voltage values are with respect to network ground terminal.

## RECOMMENDED OPERATING CONDITIONS

Over operating free-air temperature range (unless otherwise noted).

		MIN	TYP	MAX	UNIT
V <sub>CC</sub>	Supply voltage	3	3.3	3.6	V
T <sub>A</sub>	Ambient temperature (no airflow, no heat sink)	–40		+85	°C

## ELECTRICAL CHARACTERISTICS

Using the recommended operating conditions for the CDCE421 device.

PARAMETER		TEST CONDITIONS	MIN	TYP	MAX	UNIT
$V_{CC}$	Supply voltage		3	3.3	3.6	V
$I_{VCC(LVDS)}$	Total current	LVDS mode		83	103	mA
$I_{VCC(LVPECL)}$	Total current	LVPECL mode		91	110	mA
<b>LVDS OUTPUT MODE (see Figure 8)</b>						
$f_{CLK}$	Output frequency		10.9		400	MHz
$ V_{OD} $	LDVS differential output voltage	$R_L = 100 \Omega$		247	454	mV
$\Delta V_{OD}$	LVDS VOD magnitude change				50	mV
$V_{OS}$	Offset voltage	$-40^\circ\text{C}$ to $85^\circ\text{C}$	1.1		1.3	V
$\Delta V_{OS}$	VOS magnitude change				50	mV
$t_r$	Output rise time	20% to 80% of $V_{OUTpp}$		230		ps
$t_f$	Output fall time	80% to 20% of $V_{OUTpp}$		230		ps
$I_{OS}$	Short-circuit output current	Short $V_{out+}$ to ground			-30	mA
		Short $V_{out-}$ to ground			30	mA
	Duty cycle of the output waveform		45%		55%	
$T_J$	Random jitter	10kHz to 20MHz			1	ps, rms
<b>LVPECL OUTPUT MODE (see Figure 9)</b>						
$f_{CLK}$	Output frequency		10.9		1175	MHz
$V_{OH}$	LVPECL high-level output voltage		$V_{CC} - 1.2$		$V_{CC} - 0.81$	V
$V_{OL}$	LVPECL low-level output voltage		$V_{CC} - 2.17$		$V_{CC} - 1.36$	V
$ V_{OD} $	LVPECL differential output voltage		407			mV
$t_r$	Output rise time	20% to 80% of $V_{OUTpp}$		230		ps
$t_f$	Output fall time	80% to 20% of $V_{OUTpp}$		230		ps
	Duty cycle of the output waveform		45%		55%	
$T_J$	Random jitter	10kHz to 20MHz			1	ps, rms
<b>LVC MOS INPUT</b>						
$V_{IL,CMOS}$	Low-level CMOS input voltage	$V_{CC} = 3.3 \text{ V}$			$0.3 V_{CC}$	V
$V_{IH,CMOS}$	High-level CMOS input voltage	$V_{CC} = 3.3 \text{ V}$	$0.7 V_{CC}$			V
$I_{L,CMOS}$	Low-level CMOS input current	$V_{CC} = V_{CC} \text{ max}$ , $V_{IL} = 0 \text{ V}$			-200	$\mu\text{A}$
$I_{H,CMOS}$	High-level CMOS input current	$V_{CC} = V_{CC} \text{ min}$ , $V_{IH} = 3.7 \text{ V}$			200	$\mu\text{A}$

## Jitter Characteristics in Input Clock Mode

If the CDCE421 is being referenced by an external and cleaner LVCMOS input of 35.42 MHz, [Figure 6](#) shows the SSB phase noise plot of the output at 708 MHz from 100 Hz to 40 MHz from the carrier. Note the dependence of output jitter on the input reference jitter. See [Figure 11](#) for test setup.

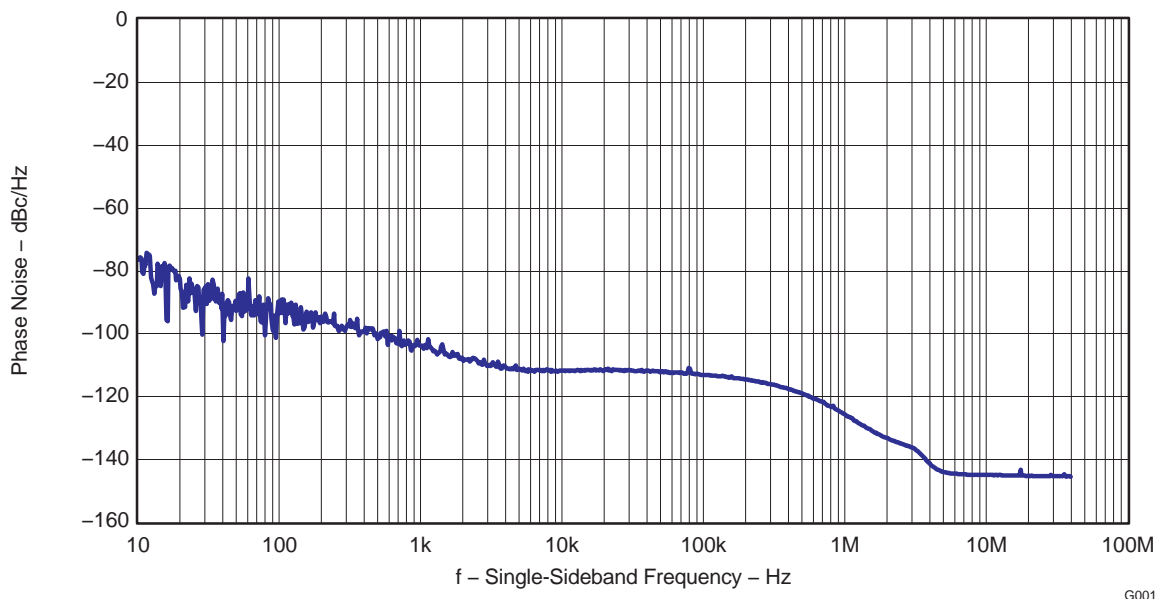

**Figure 6. Phase Noise Plot for LVPECL Output at 708 MHz**

**Table 3. Phase Noise Parameters With LVCMOS Input of 35.4 MHz and LVPECL Output at 708 MHz**

Phase noise specifications under following assumptions: input frequency $f = 35.42$ MHz (VCO = 2, prescaler = 3, output divider = 1), $f_{out} = 708$ MHz (driver mode = LVPECL)					
PARAMETER		MIN	TYP	MAX	UNIT
phn <sub>100</sub>	Phase noise at 100 Hz		-95		dBc/Hz
phn <sub>1k</sub>	Phase noise at 1 kHz		-105		dBc/Hz
phn <sub>10k</sub>	Phase noise at 10 kHz		-109		dBc/Hz
phn <sub>100k</sub>	Phase noise at 100 kHz		-114		dBc/Hz
phn <sub>1M</sub>	Phase noise at 1 MHz		-126		dBc/Hz
phn <sub>10M</sub>	Phase noise at 10 MHz		-146		dBc/Hz
phn <sub>20M</sub>	Phase noise at 20 MHz		-146		dBc/Hz
J <sub>RMS</sub>	RMS jitter integrated from 12 kHz to 20 MHz		438		fs

If the CDCE421 is being referenced by a clean external LVCMOS input of 33.33 MHz, Figure 7 shows the SSB phase noise plot of the output at 400 MHz from 100 Hz to 40 MHz from carrier. See Figure 10 for test setup.

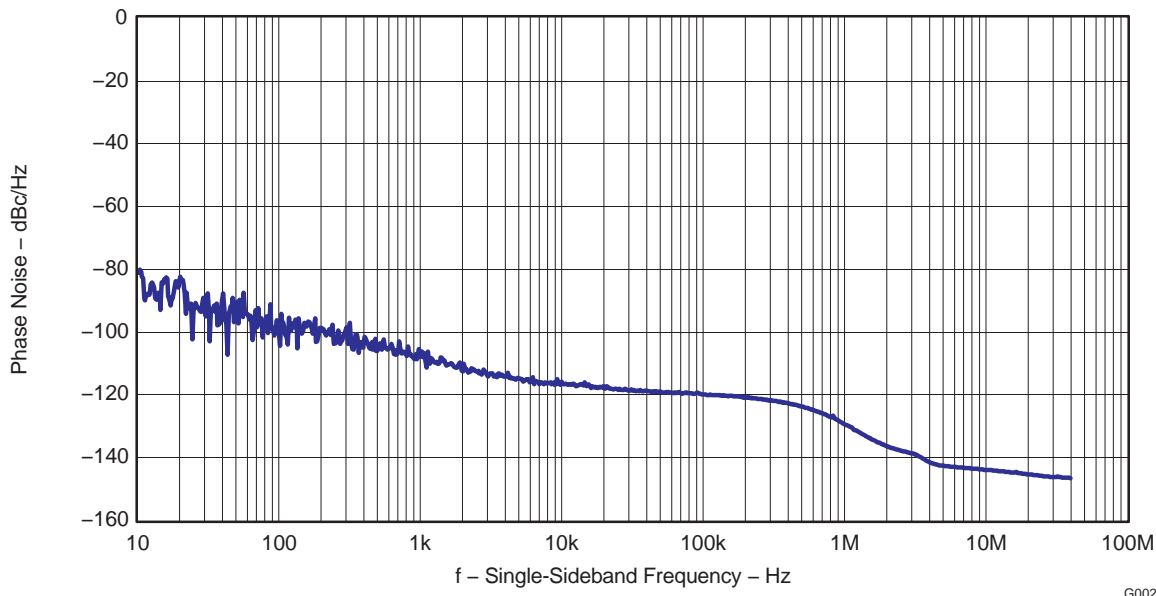

Figure 7. Phase Noise Plot for LVDS Output at 400 MHz

Table 4. Phase Noise Parameters With LVCMOS Input of 33.33 MHz and LVDS Output at 400 MHz

Phase noise specifications under following assumptions: input frequency  $f = 33.33$  MHz ( $VCO = 1$ , prescaler = 5, output divider = 1),  $f_{out} = 400$  MHz (driver mode = LVDS)

PARAMETER		MIN	TYP	MAX	UNIT
phn <sub>100</sub>	Phase noise at 100 Hz		-99		dBc/Hz
phn <sub>1k</sub>	Phase noise at 1 kHz		-109		dBc/Hz
phn <sub>10k</sub>	Phase noise at 10 kHz		-119		dBc/Hz
phn <sub>100k</sub>	Phase noise at 100 kHz		-121		dBc/Hz
phn <sub>1M</sub>	Phase noise at 1 MHz		-130		dBc/Hz
phn <sub>10M</sub>	Phase noise at 10 MHz		-147		dBc/Hz
phn <sub>20M</sub>	Phase noise at 20 MHz		-147		dBc/Hz
J <sub>RMS</sub>	RMS jitter integrated from 12 kHz to 20 MHz		409		fs

APPENDIX A: TEST CONFIGURATIONS

Test setups are used to characterize the CDCE421 device in ac and dc terminations. Figure 8 through Figure 11 illustrate all four setups used to terminate the clock signal driven by the device under test.

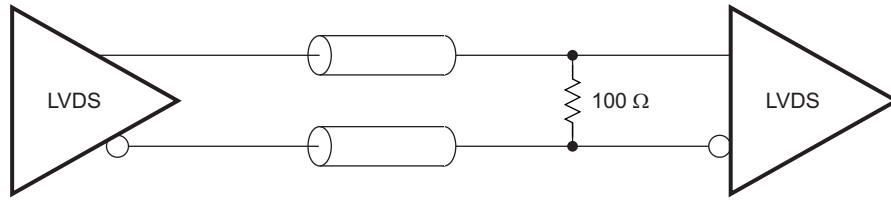

S0248-01

Figure 8. LVDS DC Termination Test Configuration

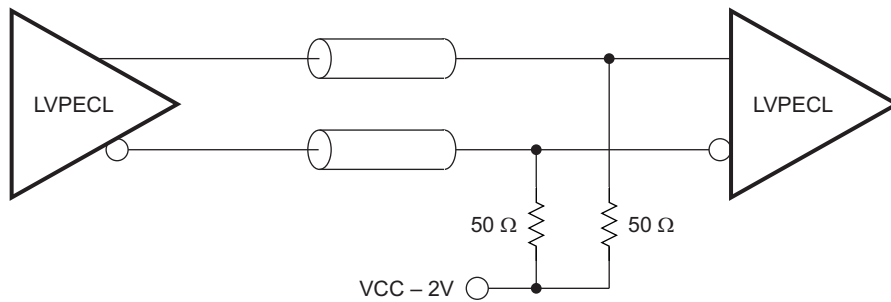

S0249-01

Figure 9. LVPECL DC Termination Test Configuration

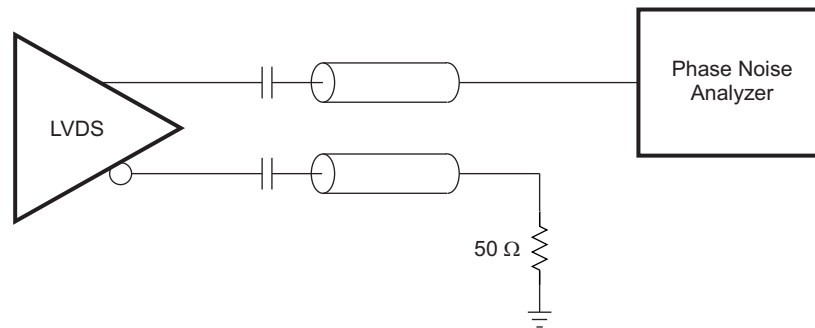

S0250-01

Figure 10. LVDS AC Termination Test Configuration

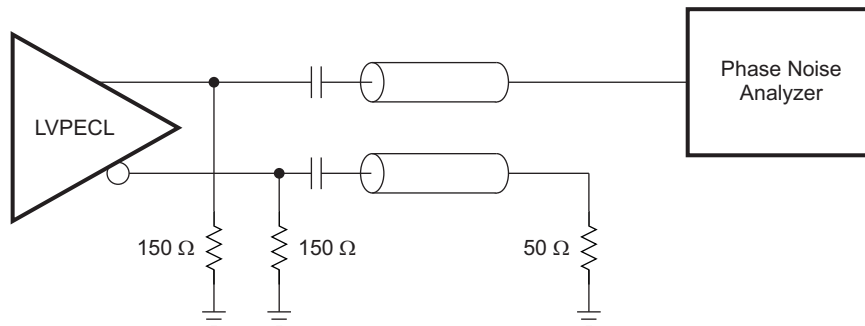

S0251-01

Figure 11. LVPECL AC Termination Test Configuration

**PACKAGING INFORMATION**

Orderable Device	Status (1)	Package Type	Package Drawing	Pins	Package Qty	Eco Plan (2)	Lead/Ball Finish (6)	MSL Peak Temp (3)	Op Temp (°C)	Device Marking (4/5)	Samples
CDCE421RGER	NRND	VQFN	RGE	24	3000	Green (RoHS & no Sb/Br)	CU NIPDAU	Level-2-260C-1 YEAR		CDCE 421	
CDCE421RGERG4	NRND	VQFN	RGE	24	3000	Green (RoHS & no Sb/Br)	CU NIPDAU	Level-2-260C-1 YEAR		CDCE 421	
CDCE421RGET	NRND	VQFN	RGE	24	250	Green (RoHS & no Sb/Br)	CU NIPDAU	Level-2-260C-1 YEAR		CDCE 421	
CDCE421RGETG4	NRND	VQFN	RGE	24	250	Green (RoHS & no Sb/Br)	CU NIPDAU	Level-2-260C-1 YEAR		CDCE 421	
CDCE421Y	NRND	DIESALE	Y	0		TBD	Call TI	Call TI			

(1) The marketing status values are defined as follows:

**ACTIVE:** Product device recommended for new designs.

**LIFEBUY:** TI has announced that the device will be discontinued, and a lifetime-buy period is in effect.

**NRND:** Not recommended for new designs. Device is in production to support existing customers, but TI does not recommend using this part in a new design.

**PREVIEW:** Device has been announced but is not in production. Samples may or may not be available.

**OBSELETE:** TI has discontinued the production of the device.

(2) Eco Plan - The planned eco-friendly classification: Pb-Free (RoHS), Pb-Free (RoHS Exempt), or Green (RoHS & no Sb/Br) - please check <http://www.ti.com/productcontent> for the latest availability information and additional product content details.

**TBD:** The Pb-Free/Green conversion plan has not been defined.

**Pb-Free (RoHS):** TI's terms "Lead-Free" or "Pb-Free" mean semiconductor products that are compatible with the current RoHS requirements for all 6 substances, including the requirement that lead not exceed 0.1% by weight in homogeneous materials. Where designed to be soldered at high temperatures, TI Pb-Free products are suitable for use in specified lead-free processes.

**Pb-Free (RoHS Exempt):** This component has a RoHS exemption for either 1) lead-based flip-chip solder bumps used between the die and package, or 2) lead-based die adhesive used between the die and leadframe. The component is otherwise considered Pb-Free (RoHS compatible) as defined above.

**Green (RoHS & no Sb/Br):** TI defines "Green" to mean Pb-Free (RoHS compatible), and free of Bromine (Br) and Antimony (Sb) based flame retardants (Br or Sb do not exceed 0.1% by weight in homogeneous material)

(3) MSL, Peak Temp. - The Moisture Sensitivity Level rating according to the JEDEC industry standard classifications, and peak solder temperature.

(4) There may be additional marking, which relates to the logo, the lot trace code information, or the environmental category on the device.

(5) Multiple Device Markings will be inside parentheses. Only one Device Marking contained in parentheses and separated by a "~" will appear on a device. If a line is indented then it is a continuation of the previous line and the two combined represent the entire Device Marking for that device.

(6) Lead/Ball Finish - Orderable Devices may have multiple material finish options. Finish options are separated by a vertical ruled line. Lead/Ball Finish values may wrap to two lines if the finish value exceeds the maximum column width.

**Important Information and Disclaimer:** The information provided on this page represents TI's knowledge and belief as of the date that it is provided. TI bases its knowledge and belief on information provided by third parties, and makes no representation or warranty as to the accuracy of such information. Efforts are underway to better integrate information from third parties. TI has taken and continues to take reasonable steps to provide representative and accurate information but may not have conducted destructive testing or chemical analysis on incoming materials and chemicals. TI and TI suppliers consider certain information to be proprietary, and thus CAS numbers and other limited information may not be available for release.

In no event shall TI's liability arising out of such information exceed the total purchase price of the TI part(s) at issue in this document sold by TI to Customer on an annual basis.

**TAPE AND REEL INFORMATION**

**REEL DIMENSIONS**

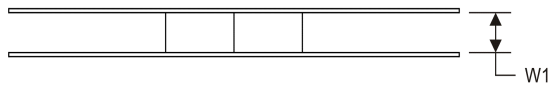
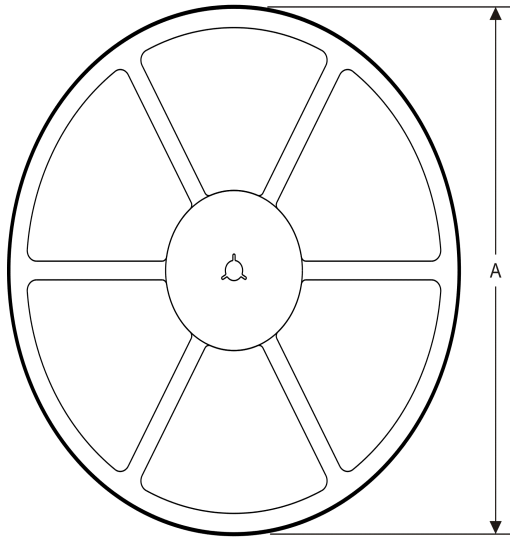

**TAPE DIMENSIONS**

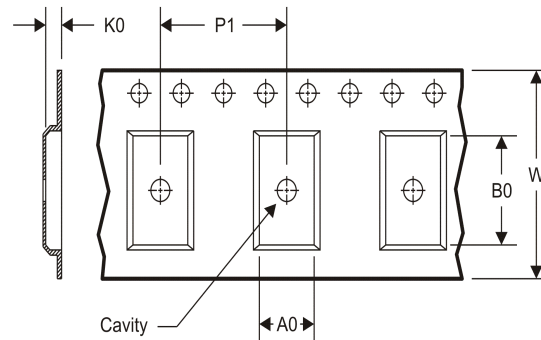

A0	Dimension designed to accommodate the component width
B0	Dimension designed to accommodate the component length
K0	Dimension designed to accommodate the component thickness
W	Overall width of the carrier tape
P1	Pitch between successive cavity centers

**TAPE AND REEL INFORMATION**

\*All dimensions are nominal

Device	Package Type	Package Drawing	Pins	SPQ	Reel Diameter (mm)	Reel Width W1 (mm)	A0 (mm)	B0 (mm)	K0 (mm)	P1 (mm)	W (mm)	Pin1 Quadrant
CDCE421RGER	VQFN	RGE	24	3000	330.0	12.4	4.25	4.25	1.15	8.0	12.0	Q2
CDCE421RGET	VQFN	RGE	24	250	180.0	12.4	4.25	4.25	1.15	8.0	12.0	Q2

**TAPE AND REEL BOX DIMENSIONS**

\*All dimensions are nominal

Device	Package Type	Package Drawing	Pins	SPQ	Length (mm)	Width (mm)	Height (mm)
CDCE421RGER	VQFN	RGE	24	3000	367.0	367.0	35.0
CDCE421RGET	VQFN	RGE	24	250	210.0	185.0	35.0

RGE (S-PVQFN-N24)

PLASTIC QUAD FLATPACK NO-LEAD

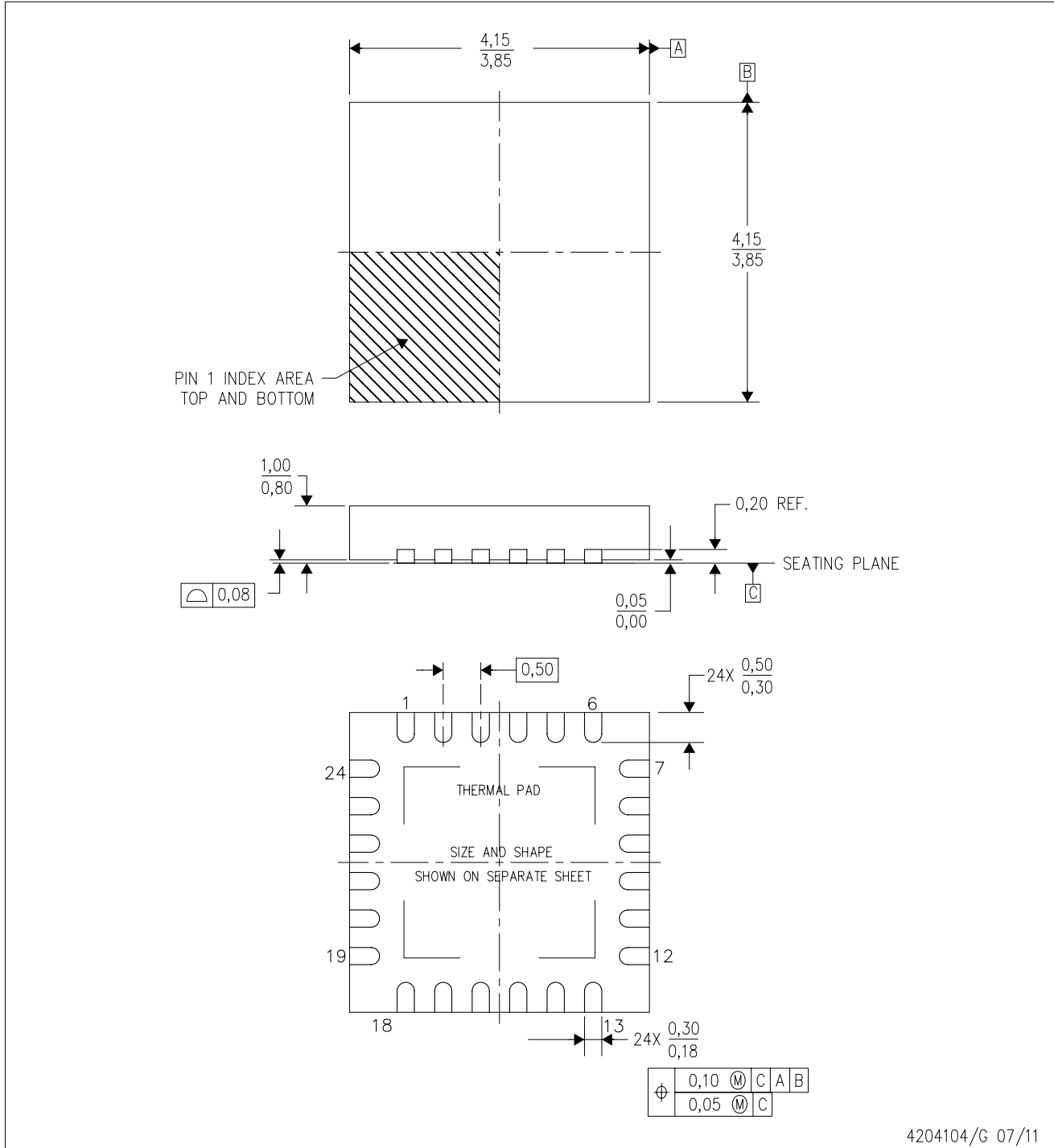

4204104/G 07/11

- NOTES:
- All linear dimensions are in millimeters. Dimensioning and tolerancing per ASME Y14.5M-1994.
  - This drawing is subject to change without notice.
  - Quad Flatpack, No-Leads (QFN) package configuration.
  - The package thermal pad must be soldered to the board for thermal and mechanical performance.
  - See the additional figure in the Product Data Sheet for details regarding the exposed thermal pad features and dimensions.
  - Falls within JEDEC MO-220.

## THERMAL PAD MECHANICAL DATA

RGE (S-PVQFN-N24)

PLASTIC QUAD FLATPACK NO-LEAD

### THERMAL INFORMATION

This package incorporates an exposed thermal pad that is designed to be attached directly to an external heatsink. The thermal pad must be soldered directly to the printed circuit board (PCB). After soldering, the PCB can be used as a heatsink. In addition, through the use of thermal vias, the thermal pad can be attached directly to the appropriate copper plane shown in the electrical schematic for the device, or alternatively, can be attached to a special heatsink structure designed into the PCB. This design optimizes the heat transfer from the integrated circuit (IC).

For information on the Quad Flatpack No-Lead (QFN) package and its advantages, refer to Application Report, QFN/SON PCB Attachment, Texas Instruments Literature No. SLUA271. This document is available at [www.ti.com](http://www.ti.com).

The exposed thermal pad dimensions for this package are shown in the following illustration.

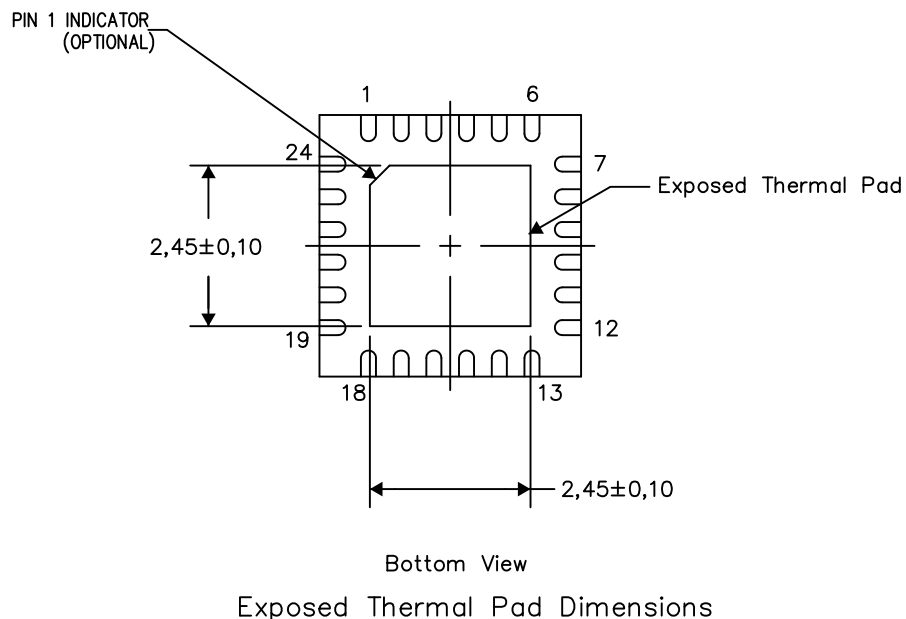

4206344-3/AK 08/15

NOTES: A. All linear dimensions are in millimeters

RGE (S-PVQFN-N24)

PLASTIC QUAD FLATPACK NO-LEAD

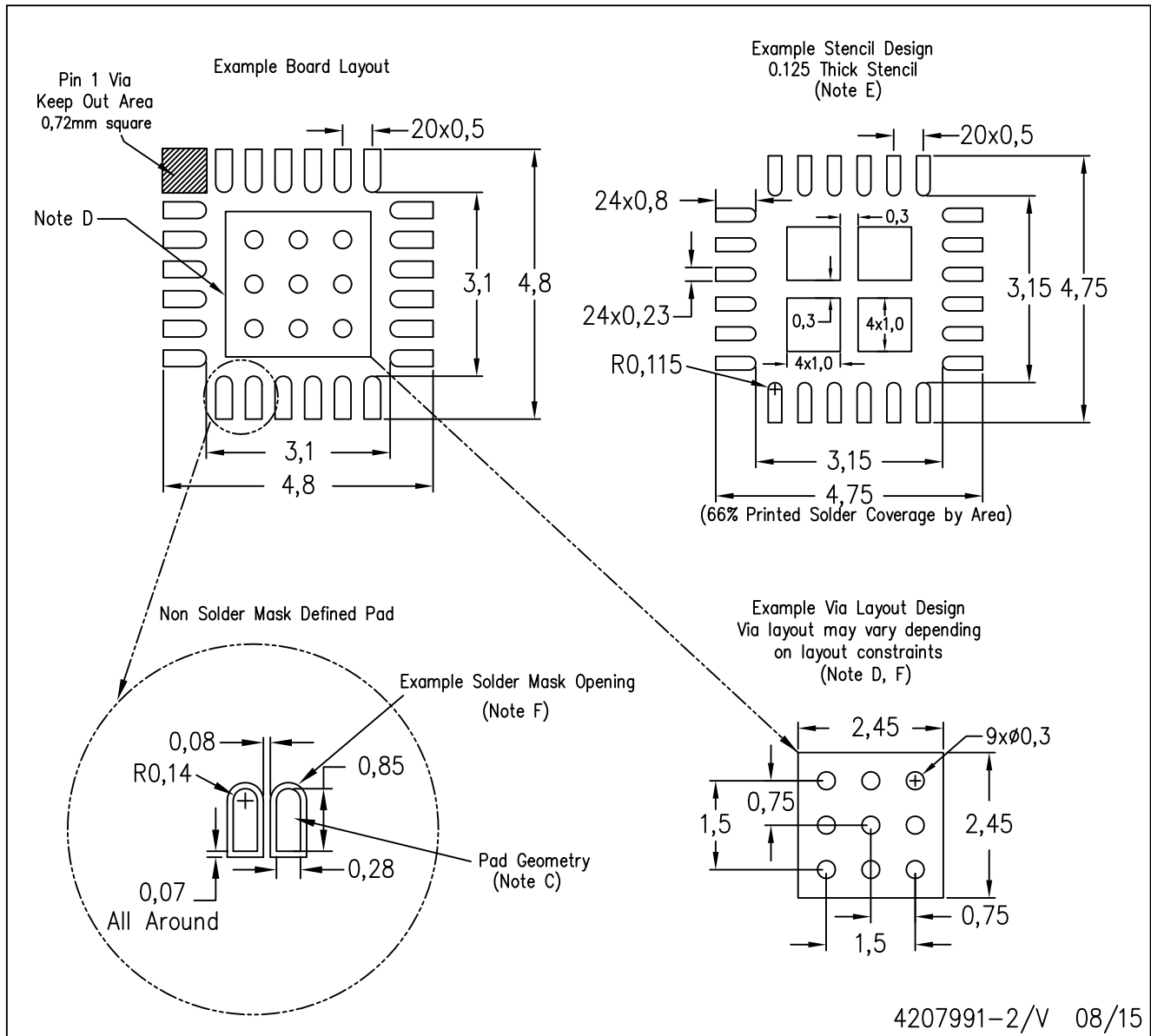

- NOTES:
- All linear dimensions are in millimeters.
  - This drawing is subject to change without notice.
  - Publication IPC-7351 is recommended for alternate designs.
  - This package is designed to be soldered to a thermal pad on the board. Refer to Application Note, Quad Flat-Pack Packages, Texas Instruments Literature No. SLUA271, and also the Product Data Sheets for specific thermal information, via requirements, and recommended board layout. These documents are available at [www.ti.com](http://www.ti.com) <<http://www.ti.com>>.
  - Laser cutting apertures with trapezoidal walls and also rounding corners will offer better paste release. Customers should contact their board assembly site for stencil design recommendations. Refer to IPC 7525 for stencil design considerations.
  - Customers should contact their board fabrication site for recommended solder mask tolerances and via tenting recommendations for vias placed in the thermal pad.

## IMPORTANT NOTICE

Texas Instruments Incorporated and its subsidiaries (TI) reserve the right to make corrections, enhancements, improvements and other changes to its semiconductor products and services per JESD46, latest issue, and to discontinue any product or service per JESD48, latest issue. Buyers should obtain the latest relevant information before placing orders and should verify that such information is current and complete. All semiconductor products (also referred to herein as "components") are sold subject to TI's terms and conditions of sale supplied at the time of order acknowledgment.

TI warrants performance of its components to the specifications applicable at the time of sale, in accordance with the warranty in TI's terms and conditions of sale of semiconductor products. Testing and other quality control techniques are used to the extent TI deems necessary to support this warranty. Except where mandated by applicable law, testing of all parameters of each component is not necessarily performed.

TI assumes no liability for applications assistance or the design of Buyers' products. Buyers are responsible for their products and applications using TI components. To minimize the risks associated with Buyers' products and applications, Buyers should provide adequate design and operating safeguards.

TI does not warrant or represent that any license, either express or implied, is granted under any patent right, copyright, mask work right, or other intellectual property right relating to any combination, machine, or process in which TI components or services are used. Information published by TI regarding third-party products or services does not constitute a license to use such products or services or a warranty or endorsement thereof. Use of such information may require a license from a third party under the patents or other intellectual property of the third party, or a license from TI under the patents or other intellectual property of TI.

Reproduction of significant portions of TI information in TI data books or data sheets is permissible only if reproduction is without alteration and is accompanied by all associated warranties, conditions, limitations, and notices. TI is not responsible or liable for such altered documentation. Information of third parties may be subject to additional restrictions.

Resale of TI components or services with statements different from or beyond the parameters stated by TI for that component or service voids all express and any implied warranties for the associated TI component or service and is an unfair and deceptive business practice. TI is not responsible or liable for any such statements.

Buyer acknowledges and agrees that it is solely responsible for compliance with all legal, regulatory and safety-related requirements concerning its products, and any use of TI components in its applications, notwithstanding any applications-related information or support that may be provided by TI. Buyer represents and agrees that it has all the necessary expertise to create and implement safeguards which anticipate dangerous consequences of failures, monitor failures and their consequences, lessen the likelihood of failures that might cause harm and take appropriate remedial actions. Buyer will fully indemnify TI and its representatives against any damages arising out of the use of any TI components in safety-critical applications.

In some cases, TI components may be promoted specifically to facilitate safety-related applications. With such components, TI's goal is to help enable customers to design and create their own end-product solutions that meet applicable functional safety standards and requirements. Nonetheless, such components are subject to these terms.

No TI components are authorized for use in FDA Class III (or similar life-critical medical equipment) unless authorized officers of the parties have executed a special agreement specifically governing such use.

Only those TI components which TI has specifically designated as military grade or "enhanced plastic" are designed and intended for use in military/aerospace applications or environments. Buyer acknowledges and agrees that any military or aerospace use of TI components which have **not** been so designated is solely at the Buyer's risk, and that Buyer is solely responsible for compliance with all legal and regulatory requirements in connection with such use.

TI has specifically designated certain components as meeting ISO/TS16949 requirements, mainly for automotive use. In any case of use of non-designated products, TI will not be responsible for any failure to meet ISO/TS16949.

### Products

Audio	<a href="http://www.ti.com/audio">www.ti.com/audio</a>
Amplifiers	<a href="http://amplifier.ti.com">amplifier.ti.com</a>
Data Converters	<a href="http://dataconverter.ti.com">dataconverter.ti.com</a>
DLP® Products	<a href="http://www.dlp.com">www.dlp.com</a>
DSP	<a href="http://dsp.ti.com">dsp.ti.com</a>
Clocks and Timers	<a href="http://www.ti.com/clocks">www.ti.com/clocks</a>
Interface	<a href="http://interface.ti.com">interface.ti.com</a>
Logic	<a href="http://logic.ti.com">logic.ti.com</a>
Power Mgmt	<a href="http://power.ti.com">power.ti.com</a>
Microcontrollers	<a href="http://microcontroller.ti.com">microcontroller.ti.com</a>
RFID	<a href="http://www.ti-rfid.com">www.ti-rfid.com</a>
OMAP Applications Processors	<a href="http://www.ti.com/omap">www.ti.com/omap</a>
Wireless Connectivity	<a href="http://www.ti.com/wirelessconnectivity">www.ti.com/wirelessconnectivity</a>

### Applications

Automotive and Transportation	<a href="http://www.ti.com/automotive">www.ti.com/automotive</a>
Communications and Telecom	<a href="http://www.ti.com/communications">www.ti.com/communications</a>
Computers and Peripherals	<a href="http://www.ti.com/computers">www.ti.com/computers</a>
Consumer Electronics	<a href="http://www.ti.com/consumer-apps">www.ti.com/consumer-apps</a>
Energy and Lighting	<a href="http://www.ti.com/energy">www.ti.com/energy</a>
Industrial	<a href="http://www.ti.com/industrial">www.ti.com/industrial</a>
Medical	<a href="http://www.ti.com/medical">www.ti.com/medical</a>
Security	<a href="http://www.ti.com/security">www.ti.com/security</a>
Space, Avionics and Defense	<a href="http://www.ti.com/space-avionics-defense">www.ti.com/space-avionics-defense</a>
Video and Imaging	<a href="http://www.ti.com/video">www.ti.com/video</a>

### TI E2E Community

[e2e.ti.com](http://e2e.ti.com)

## Looking for pricing, stock, or lifecycle information?

Click below to explore more details on WIN SOURCE:

 [View CDCE421RGET](#) on WIN SOURCE

 [Texas Instruments](#) Information

## Optimize Your Supply Chain with WIN SOURCE Solutions

-  Global Sourcing Solution
-  Obsolete Management
-  Cost Control Management
-  Shortage Management
-  Alternative Solution
-  Excess Inventory Management