



**THE DATASHEET OF
SN65HVD3083EDGSG4**



SN65HVD308xE Low-Power RS-485 Full-Duplex Drivers and Receivers

1 Features

- Low quiescent power
 - 375 μ A (Typical) Enabled mode
 - 2 nA (Typical) Shutdown mode
- Small MSOP package
- 1/8 Unit-Load—Up to 256 nodes per bus
- 16 kV Bus-pin ESD protection, 6 kV all pins
- Failsafe receiver (bus open, short, idle)
- TIA/EIA-485A Standard compliant
- RS-422 Compatible
- Power-up, power-down glitch-free operation

2 Applications

- Motion controllers
- Point-of-sale (POS) terminals
- Rack-to-rack communications
- Industrial networks
- Power inverters
- Battery-powered applications
- Building automation

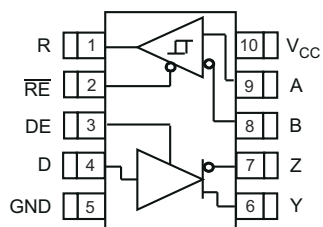
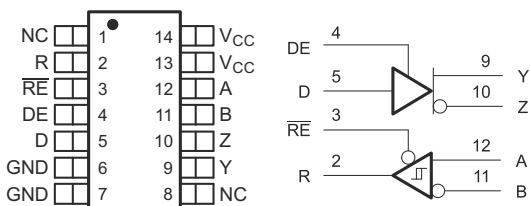

Figure 2-1. DGS Package (Top View)



NC - No internal connection
 Pins 6 and 7 are connected together internally
 Pins 13 and 14 are connected together internally

Figure 2-2. D Package (Top View)

3 Description

Each of these devices is a balanced driver and receiver designed for full-duplex RS-485 or RS-422 data bus networks. Powered by a 5-V supply, they are fully compliant with the TIA/EIA-485A standard.

With controlled bus output transition times, the devices are suitable for signaling rates from 200 kbps to 20 Mbps.

The devices are designed to operate with a low supply current, less than 1 mA (typical), exclusive of the load. When in the inactive shutdown mode, the supply current drops to a few nanoamps, making these devices ideal for power-sensitive applications.

The wide common-mode range and high ESD protection levels of these devices make them suitable for demanding applications such as motion controllers, electrical inverters, industrial networks, and cabled chassis interconnects where noise tolerance is essential.

These devices are characterized for operation over the temperature range -40°C to 85°C

Device Information

PART NUMBER	SIGNALING RATE	PACKAGE ⁽¹⁾
SN65HVD3080E	200 kbps	DGS, DGSR 10-pin MSOP ⁽²⁾
SN65HVD3083E	1 Mbps	
SN65HVD3086E	20 Mbps	D 14-pin SOIC

- (1) For the most current package and ordering information, see the Package Option Addendum at the end of this document, or see the TI website at www.ti.com.
- (2) The R suffix indicated tape and reel.

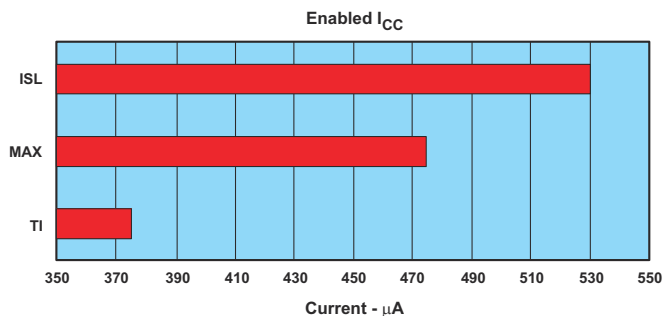

Table of Contents

1 Features	1	5.11 Typical Characteristics.....	7
2 Applications	1	6 Parameter Measurement Information	8
3 Description	1	7 Device Information	11
4 Revision History	2	7.1 Function Tables.....	11
5 Specifications	3	7.2 Equivalent Input and Output Schematic Diagrams...	12
5.1 Absolute Maximum Ratings.....	3	8 Application Information	13
5.2 Power Dissipation Ratings.....	3	8.1 Hot-Plugging.....	13
5.3 Electrostatic Discharge Protection.....	3	9 Device and Documentation Support	14
5.4 Supply Current.....	4	9.1 Receiving Notification of Documentation Updates...	14
5.5 Recommended Operating Conditions.....	4	9.2 Support Resources.....	14
5.6 Thermal Information.....	4	9.3 Trademarks.....	14
5.7 Driver Electrical Characteristics.....	5	9.4 Electrostatic Discharge Caution.....	14
5.8 Driver Switching Characteristics.....	5	9.5 Glossary.....	14
5.9 Receiver Electrical Characteristics.....	6	10 Mechanical, Packaging, and Orderable Information	14
5.10 Receiver Switching Characteristics.....	6		

4 Revision History

NOTE: Page numbers for previous revisions may differ from page numbers in the current version.

Changes from Revision E (November 2012) to Revision F (March 2023)	Page
• Deleted the Ordering Information table.....	1
• Added the Device Information table.....	1
• Added the <i>Thermal Information</i> table.....	4
• Changed the <i>Typical Characteristics</i>	7

Changes from Revision D (January 2011) to Revision E (November 2012)	Page
• Added Power-Up, Power-Down Glitch-Free Operation to <i>Features</i>	1
• Changed ENABLE in DRIVER FUNCTION TABLE from L to L or OPEN.....	11
• Changed ENABLE in RECEIVER FUNCTION TABLE from H to H or OPEN.....	11
• Added <i>Application Information</i> section.....	13

Changes from Revision C (December 2009) to Revision D (January 2011)	Page
• Added Differential input voltage dynamic to RECOMMENDED OPERATING CONDITIONS.....	4
• Added Figure 7-1	11

Changes from Revision B (March 2007) to Revision C ()	Page
• Added D package.....	1
• Added D package information to Power Dissipation Ratings.....	3
• Changed Electrostatic Discharge Protection.....	3
• Changed Supply Current information.....	4
• Changed Receiver Switching Characteristics.....	6
• Changed Figure 6-5	8
• Changed Figure 6-6	8

5 Specifications

5.1 Absolute Maximum Ratings

over operating free-air temperature range unless otherwise noted⁽¹⁾

		UNIT
V_{CC}	Supply voltage range ⁽²⁾	-0.3 V to 7 V
$V_{(A)}, V_{(B)}, V_{(Y)}, V_{(Z)}$	Voltage range at any bus terminal (A, B, Y, Z)	-9 V to 14 V
$V_{(TRANS)}$	Voltage input, transient pulse through 100 Ω . See Figure 6-10 (A, B, Y, Z)	-50 to 50 V
V_I	Input voltage range (D, DE, \overline{RE})	-0.3 V to $V_{CC}+0.3$ V
P_D	Continuous total power dissipation	See the dissipation rating table
T_J	Junction temperature	170°C

- (1) Stresses beyond those listed under absolute maximum ratings may cause permanent damage to the device. These are stress ratings only, and functional operation of the device at these or any other conditions beyond those indicated under recommended operating conditions is not implied. Exposure to absolute-maximum-rated conditions for extended periods may affect device reliability.
- (2) All voltage values, except differential I/O bus voltages, are with respect to network ground terminal.

5.2 Power Dissipation Ratings

PACKAGE	$T_A < 25^\circ\text{C}$	DERATING FACTOR ⁽¹⁾ ABOVE $T_A < 25^\circ\text{C}$	$T_A = 85^\circ\text{C}$
10-pin MSOP (DGS)	463 mW	3.71 mW/°C	241 mW
14-pin SOIC (D)	765 mW	6.1 mW/°C	400 mW

- (1) This is the inverse of the junction-to-ambient thermal resistance when board-mounted and with no air flow.

5.3 Electrostatic Discharge Protection

PARAMETER	TEST CONDITIONS	MIN	TYP	MAX	UNIT
Human Body Model ⁽¹⁾	A,B,Y,Z, and GND		16		kV
	All pins		6		kV
Charged Device Mode ⁽²⁾	All pins		1.5		kV
Machine Model ⁽³⁾	All pins		400		V

- (1) Tested in accordance JEDEC Standard 22, Test Method A114-A. Bus pin stressed with respect to a common connection of GND and V_{CC} .
- (2) Tested in accordance JEDEC Standard 22, Test Method C101.
- (3) Tested in accordance JEDEC Standard 22, Test Method A115.

5.4 Supply Current

over recommended operating conditions unless otherwise noted

PARAMETER		TEST CONDITIONS	MIN	TYP	MAX	UNIT	
I _{CC}	Supply current	\overline{RE} at 0 V, D and DE at V _{CC} , No load		375	750	μA	
		\overline{RE} at 0 V, D and DE at 0 V, No load		300	680	μA	
		\overline{RE} at V _{CC} , D and DE at V _{CC} , No load	Receiver disabled, Driver enabled		240	600	μA
		\overline{RE} and D at V _{CC} , DE at 0 V, No load	Receiver disabled, Driver disabled		2	1000	nA

5.5 Recommended Operating Conditions

over operating free-air temperature range unless otherwise noted

		MIN	NOM	MAX	UNIT
V _{CC}	Supply voltage	4.5	5	5.5	V
V _I or V _{IC}	Voltage at any bus terminal (separately or common mode)	-7 ⁽¹⁾		12	
V _{IH}	High-level input voltage	D, DE, \overline{RE}		V _{CC}	V
V _{IL}	Low-level input voltage	D, DE, \overline{RE}		0.8	
V _{ID}	Differential input voltage			-12	V
		Dynamic, See Figure 7-1		12	V
I _{OH}	High-level output current	Driver		-60	mA
		Receiver		-10	
I _{OL}	Low-level output current	Driver		60	mA
		Receiver		10	
T _J	Junction temperature			150	°C
T _A	Ambient still-air temperature	-40		85	

(1) The algebraic convention, in which the least positive (most negative) limit is designated as minimum is used in this data sheet.

5.6 Thermal Information

THERMAL METRIC ⁽¹⁾		D (SOIC)	DGS (VSSOP)	UNIT
		14 PINS	10 PINS	
R _{θJA}	Junction-to-ambient thermal resistance	93.2	75.8	°C/W
R _{θJC(top)}	Junction-to-case (top) thermal resistance	47.5	22.0	°C/W
R _{θJB}	Junction-to-board thermal resistance	49.4	44.9	°C/W
ψ _{JT}	Junction-to-top characterization parameter	11.2	1.0	°C/W
ψ _{JB}	Junction-to-board characterization parameter	48.9	44.3	°C/W

(1) For more information about traditional and new thermal metrics, see the *Semiconductor and IC Package Thermal Metrics* application report, [SPRA953](#).

5.7 Driver Electrical Characteristics

over recommended operating conditions unless otherwise noted

PARAMETER		TEST CONDITIONS	MIN	TYP	MAX	UNIT
V _{OD}	Differential output voltage	No load, I _O = 0	3	4.3	V _{CC}	V
		R _L = 54 Ω, See Figure 6-1	1.5	2.3		
		V _{test} = -7 V to 12 V, See Figure 6-2	1.5			
		R _L = 100 Ω, See Figure 6-1	2			
Δ V _{OD}	Change in magnitude of differential output voltage	R _L = 54 Ω, See Figure 6-1 and Figure 6-2	-0.2	0	0.2	V
V _{OC(SS)}	Steady-state common-mode output voltage	See Figure 6-3	1	2.6	3	V
ΔV _{OC(SS)}	Common-mode output voltage (Dominant)		-0.1	0	0.1	
V _{OC(PP)}	Peak-to-peak common-mode output voltage		0.5			
I _{Z(Y)} or I _{Z(Z)}	High-impedance state output current	V _{CC} = 0 V, V _(Z) or V _(Y) = 12 V Other input at 0 V			1	μA
		V _{CC} = 0 V, V _(Z) or V _(Y) = -7 V Other input at 0 V	-1			
		V _{CC} = 5 V, V _(Z) or V _(Y) = 12 V Other input at 0 V			1	
		V _{CC} = 5 V, V _(Z) or V _(Y) = -7 V Other input at 0 V	-1			
I _I	Input current	D, DE	-100		100	μA
I _{OS}	Short-circuit output current	-7 V ≤ V _O ≤ 12 V	-250		250	mA

5.8 Driver Switching Characteristics

over recommended operating conditions unless otherwise noted

PARAMETER		TEST CONDITIONS	MIN	TYP	MAX	UNIT	
t _{PLH} , t _{PHL}	Propagation delay time, low-to-high-level output Propagation delay time, high-to-low-level output	HVD3080E HVD3083E HVD3086E		0.7	1.3	μs	
				150	500	ns	
				12	20	ns	
t _r , t _f	Differential output signal rise time Differential output signal fall time	HVD3080E HVD3083E HVD3086E	R _L = 54 Ω, C _L = 50 pF, See Figure 6-4	0.5	0.9	1.5	μs
				200	300	ns	
				7	15	ns	
t _{sk(p)}	Pulse skew (t _{PHL} - t _{PLH})	HVD3080E HVD3083E HVD3086E		20	200	ns	
				5	50	ns	
				1.4	5	ns	
t _{PZH}	Propagation delay time, high-impedance-to-high-level output	HVD3080E HVD3083E HVD3086E	R _L = 110 Ω, RE at 0 V, See Figure 6-5	2.5	7	μs	
				1	2.5	μs	
				13	30	ns	
t _{PHZ}	Propagation delay time, high-level-to-high-impedance output	HVD3080E HVD3083E HVD3086E	R _L = 110 Ω, RE at 0 V, See Figure 6-5	80	200	ns	
				60	100	ns	
				12	30	ns	
t _{PZL}	Propagation delay time, high-impedance-to-low-level output	HVD3080E HVD3083E HVD3086E	R _L = 110 Ω, RE at 0 V, See Figure 6-6	2.5	7	μs	
				1	2.5	μs	
				13	30	ns	
t _{PLZ}	Propagation delay time, low-level-to-high-impedance output	HVD3080E HVD3083E HVD3086E	R _L = 110 Ω, RE at 0 V, See Figure 6-6	80	200	ns	
				60	100	ns	
				12	30	ns	
t _{PZH} , t _{PZL}	Propagation delay time, standby-to-high-level output (See Figure 6-5) Propagation delay time, standby-to-low-level output (See Figure 6-6)	R _L = 110 Ω, RE at 3 V		3.5	7	μs	

5.9 Receiver Electrical Characteristics

over recommended operating conditions unless otherwise noted

PARAMETER		TEST CONDITIONS	MIN	TYP ⁽¹⁾	MAX	UNIT	
V _{IT+}	Positive-going differential input threshold voltage	I _O = -10 mA	-0.08	-0.01		V	
V _{IT-}	Negative-going differential input threshold voltage	I _O = 10 mA	-0.2	-0.1			
V _{hys}	Hysteresis voltage (V _{IT+} - V _{IT-})			30		mV	
V _{OH}	High-level output voltage	V _{ID} = 200 mV, I _{OH} = -10 mA, See Figure 6-7 and Figure 6-8	4	4.6		V	
V _{OL}	Low-level output voltage	V _{ID} = -200 mV, I _{OH} = 10 mA, See Figure 6-7 and Figure 6-8	0.15		0.4	V	
I _{OZ}	High-impedance-state output current	V _O = 0 or V _{CC}	-1		1	μA	
I _I	Bus input current	Other input at 0V	V _A or V _B = 12 V		0.04	0.11	mA
			V _A or V _B = 12 V, V _{CC} = 0 V		0.06	0.13	
			V _A or V _B = -7 V		-0.1	-0.04	
			V _A or V _B = -7 V, V _{CC} = 0 V		-0.05	-0.03	
I _{IH}	High-level input current	V _{IH} = 2 V	-60	-30		μA	
I _{IL}	Low-level input current	V _{IL} = 0.8 V	-60	-30		μA	
C _{ID}	Differential input capacitance	V _I = 0.4 sin(4E6πt) + 0.5 V		7		pF	

(1) All typical values are at 25°C and with a 3.3-V supply.

5.10 Receiver Switching Characteristics

over recommended operating conditions unless otherwise noted

PARAMETER		TEST CONDITIONS	MIN	TYP	MAX	UNIT
t _{PLH}	Propagation delay time, low-to-high-level output	V _{ID} = -1.5 V to 1.5 V, C _L = 15 pF, See Figure 6-8		75	100	ns
t _{PHL}	Propagation delay time, high-to-low-level output			79	100	
t _{sk(p)}	Pulse skew ((t _{PHL} - t _{PLH}))			4	10	
t _r	Output signal rise time			1.5	3	
t _f	Output signal fall time			1.8	3	
t _{PZH} , t _{PZL}	Output enable time	DE at V _{CC} , See Figure 6-9		10	50	ns
		From standby DE at GND, See Figure 6-9		1.7	3.5	μs
t _{PHZ} , t _{PLZ}	Output disable time	DE at GND or V _{CC} , See Figure 6-9		7	50	ns

5.11 Typical Characteristics

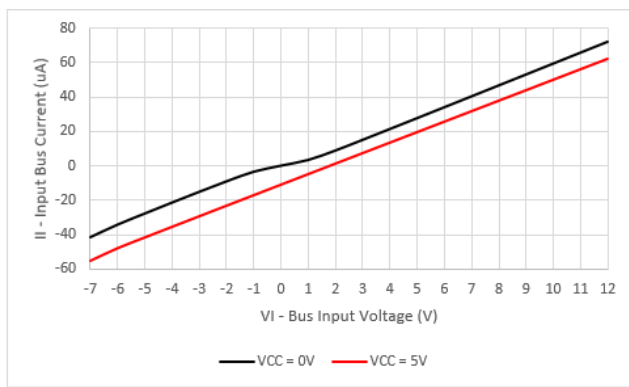

Figure 5-1. Input Bias Current vs BUS Input Voltage

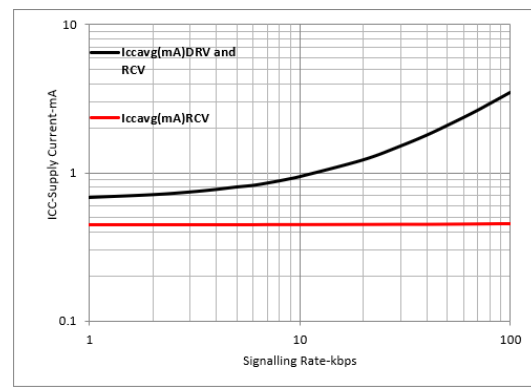

Figure 5-2. HVD3080E Supply Current vs Signaling Rate

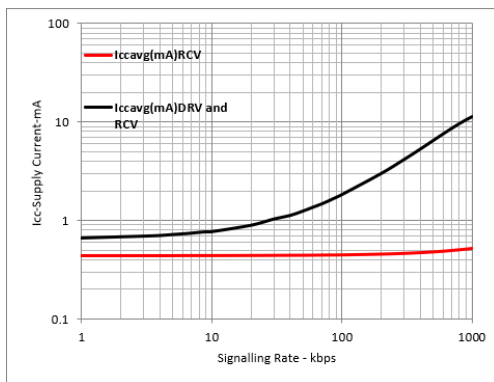

Figure 5-3. HVD3083E Supply Current vs Signaling Rate

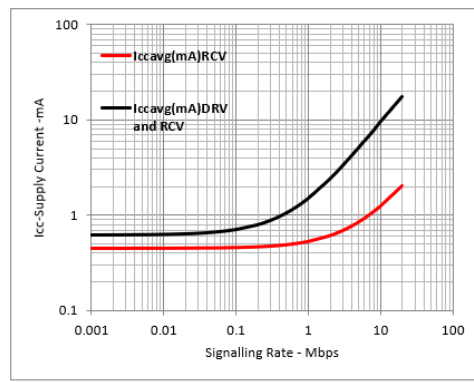

Figure 5-4. HVD3086E Supply Current vs Signaling Rate

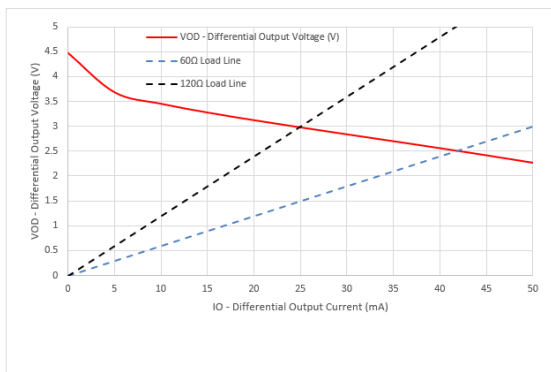

Figure 5-5. Differential Output Voltage vs Differential Output Current

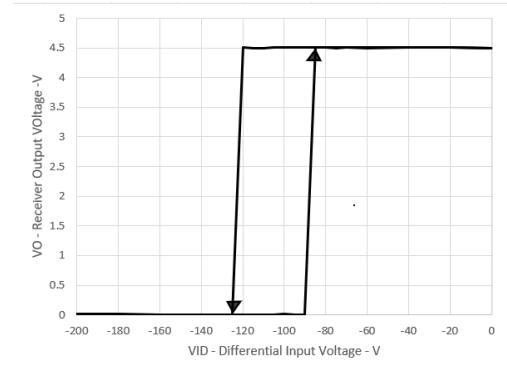

Figure 5-6. Receiver Output Voltage vs Differential Input Voltage

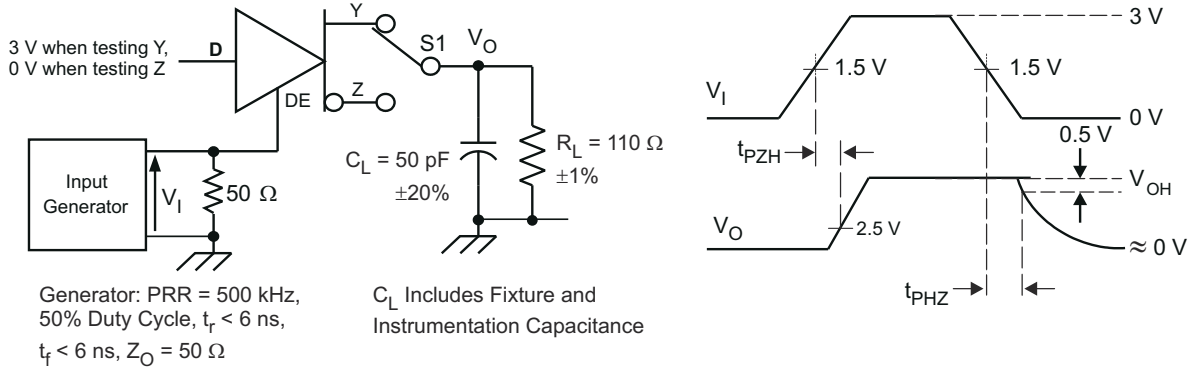

Figure 6-5. Driver High-Level Output Enable and Disable Time Test Circuit and Voltage Waveforms

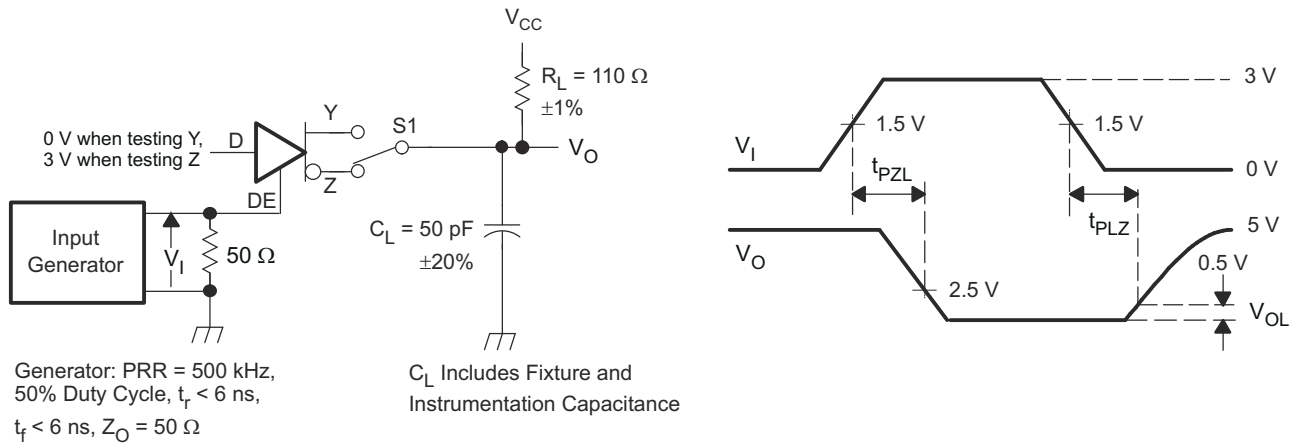

Figure 6-6. Driver Low-Level Output Enable and Disable Time Test Circuit and Voltage Waveforms

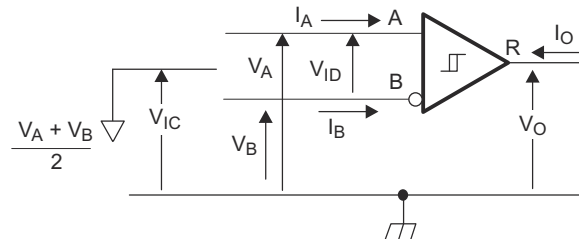

Figure 6-7. Receiver Voltage and Current Definitions

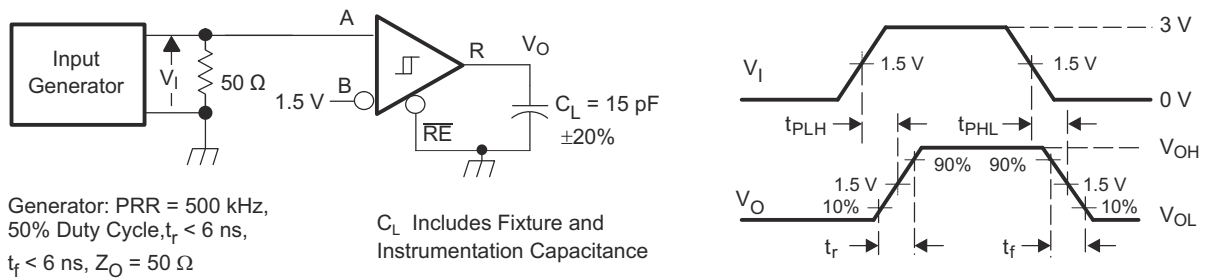

Figure 6-8. Receiver Switching Test Circuit and Voltage Waveforms

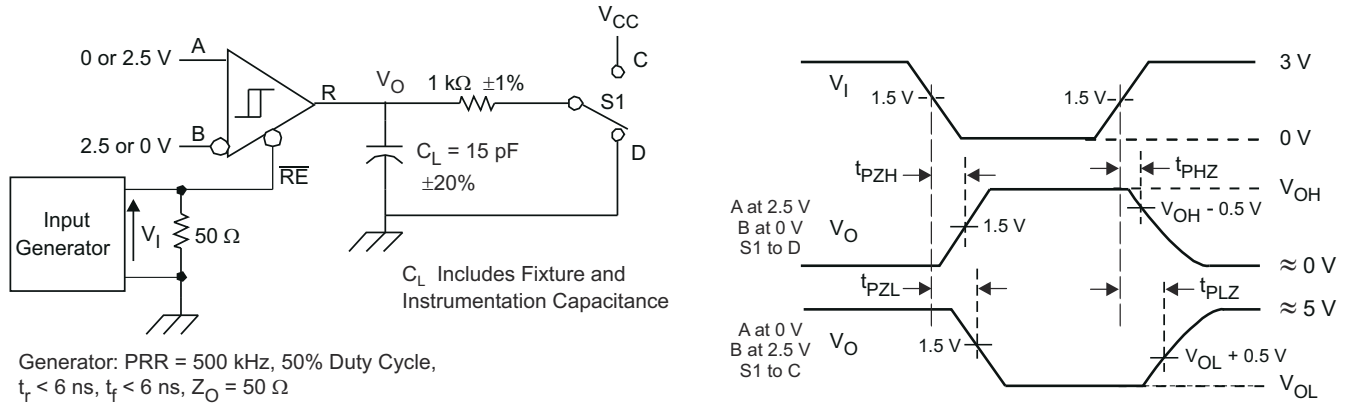
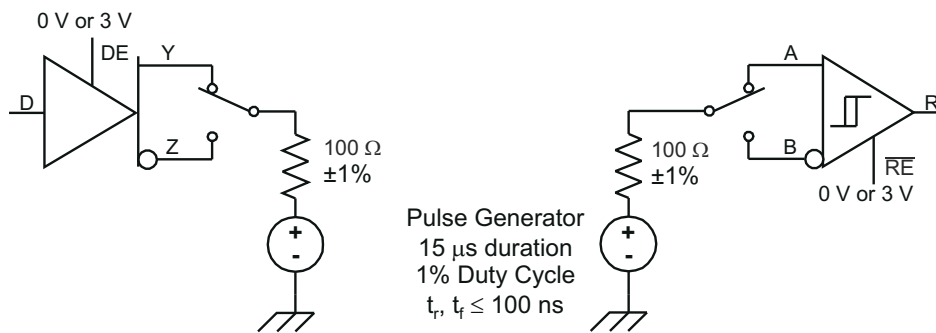

Figure 6-9. Receiver Enable and Disable Test Circuit and Voltage Waveforms



A. This test is conducted to test survivability only. Data stability at the R output is not specified.

Figure 6-10. Transient Overvoltage Test Circuit

7 Device Information

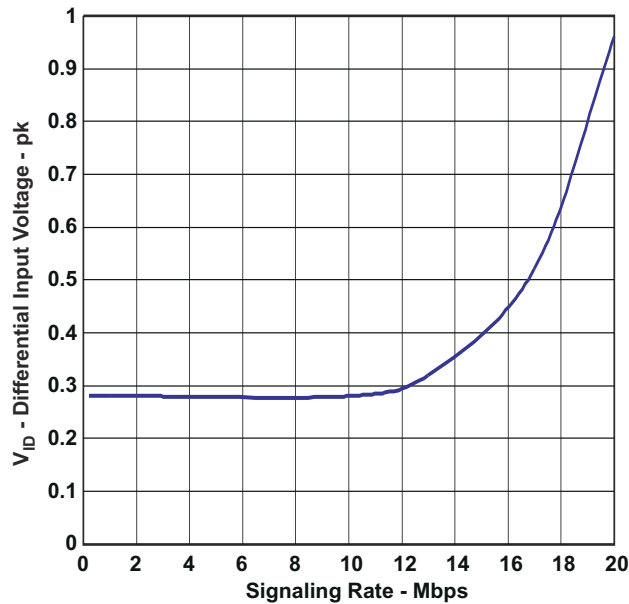

Figure 7-1. Recommended Minimum Differential Input Voltage vs Signaling Rate

7.1 Function Tables

DRIVER

INPUT ⁽¹⁾	ENABLE	OUTPUTS	
D	DE	Y	Z
H	H	H	L
L	H	L	H
X	L or OPEN	Z	Z
Open	H	H	L

(1) H = high level, L = low level, Z = high impedance, X = irrelevant, ? = indeterminate

RECEIVER

DIFFERENTIAL INPUTS ⁽¹⁾ V _{ID} = V _(A) - V _(B)	ENABLE RE	OUTPUT R
V _{ID} ≤ -0.2 V	L	L
-0.2 V < V _{ID} < -0.01 V	L	?
-0.01 V ≤ V _{ID}	L	H
X	H or OPEN	Z
Open Circuit	L	H
BUS Idle	L	H
Short Circuit	L	H

(1) H = high level, L = low level, Z = high impedance, X = irrelevant, ? = indeterminate

7.2 Equivalent Input and Output Schematic Diagrams

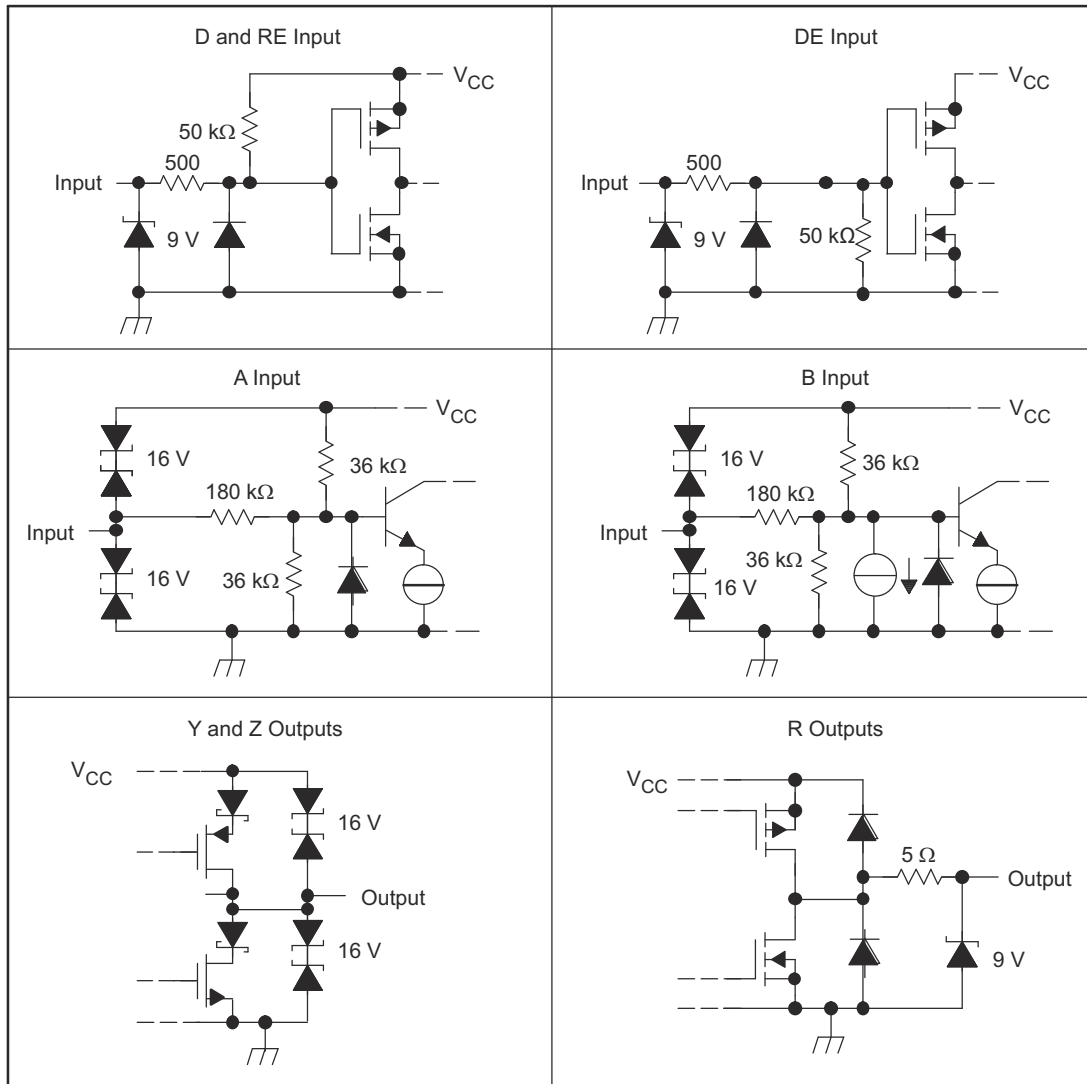

8 Application Information

Note

Information in the following applications sections is not part of the TI component specification, and TI does not warrant its accuracy or completeness. TI's customers are responsible for determining suitability of components for their purposes, as well as validating and testing their design implementation to confirm system functionality.

8.1 Hot-Plugging

These devices are designed to operate in “hot swap” or “hot pluggable” applications. Key features for hot-pluggable applications are power-up, power-down glitch free operation, default disabled input/output pins, and receiver failsafe. An internal Power-On Reset circuit keeps the outputs in a high-impedance state until the supply voltage has reached a level at which the device will reliably operate. This ensures that no spurious transitions (glitches) will occur on the bus pin outputs as the power supply turns on or turns off.

As shown in the device FUNCTION TABLES, the ENABLE inputs have the feature of default disable on both the driver enable and receiver enable. This ensures that the device will neither drive the bus nor report data on the R pin until the associated controller actively drives the enable pins.

9 Device and Documentation Support

9.1 Receiving Notification of Documentation Updates

To receive notification of documentation updates, navigate to the device product folder on ti.com. Click on *Subscribe to updates* to register and receive a weekly digest of any product information that has changed. For change details, review the revision history included in any revised document.

9.2 Support Resources

TI E2E™ [support forums](#) are an engineer's go-to source for fast, verified answers and design help — straight from the experts. Search existing answers or ask your own question to get the quick design help you need.

Linked content is provided "AS IS" by the respective contributors. They do not constitute TI specifications and do not necessarily reflect TI's views; see TI's [Terms of Use](#).

9.3 Trademarks

TI E2E™ is a trademark of Texas Instruments.
All trademarks are the property of their respective owners.

9.4 Electrostatic Discharge Caution



This integrated circuit can be damaged by ESD. Texas Instruments recommends that all integrated circuits be handled with appropriate precautions. Failure to observe proper handling and installation procedures can cause damage.

ESD damage can range from subtle performance degradation to complete device failure. Precision integrated circuits may be more susceptible to damage because very small parametric changes could cause the device not to meet its published specifications.

9.5 Glossary

[TI Glossary](#) This glossary lists and explains terms, acronyms, and definitions.

10 Mechanical, Packaging, and Orderable Information

The following pages include mechanical, packaging, and orderable information. This information is the most current data available for the designated devices. This data is subject to change without notice and revision of this document. For browser-based versions of this data sheet, refer to the left-hand navigation.

PACKAGING INFORMATION

Orderable Device	Status (1)	Package Type	Package Drawing	Pins	Package Qty	Eco Plan (2)	Lead finish/ Ball material (6)	MSL Peak Temp (3)	Op Temp (°C)	Device Marking (4/5)	Samples
SN65HVD3080EDGSR	ACTIVE	VSSOP	DGS	10	2500	RoHS & Green	SN	Level-2-260C-1 YEAR	-40 to 85	BTT	Samples
SN65HVD3083EDGSR	ACTIVE	VSSOP	DGS	10	2500	RoHS & Green	SN	Level-2-260C-1 YEAR	-40 to 85	BTU	Samples
SN65HVD3086EDGSR	ACTIVE	VSSOP	DGS	10	2500	RoHS & Green	SN	Level-2-260C-1 YEAR	-40 to 85	BTF	Samples
SN65HVD3086EDR	ACTIVE	SOIC	D	14	2500	RoHS & Green	NIPDAU	Level-1-260C-UNLIM	-40 to 85	HVD3086E	Samples

(1) The marketing status values are defined as follows:

ACTIVE: Product device recommended for new designs.

LIFEBUY: TI has announced that the device will be discontinued, and a lifetime-buy period is in effect.

NRND: Not recommended for new designs. Device is in production to support existing customers, but TI does not recommend using this part in a new design.

PREVIEW: Device has been announced but is not in production. Samples may or may not be available.

OBSELETE: TI has discontinued the production of the device.

(2) **RoHS:** TI defines "RoHS" to mean semiconductor products that are compliant with the current EU RoHS requirements for all 10 RoHS substances, including the requirement that RoHS substance do not exceed 0.1% by weight in homogeneous materials. Where designed to be soldered at high temperatures, "RoHS" products are suitable for use in specified lead-free processes. TI may reference these types of products as "Pb-Free".

RoHS Exempt: TI defines "RoHS Exempt" to mean products that contain lead but are compliant with EU RoHS pursuant to a specific EU RoHS exemption.

Green: TI defines "Green" to mean the content of Chlorine (Cl) and Bromine (Br) based flame retardants meet JS709B low halogen requirements of <=1000ppm threshold. Antimony trioxide based flame retardants must also meet the <=1000ppm threshold requirement.

(3) MSL, Peak Temp. - The Moisture Sensitivity Level rating according to the JEDEC industry standard classifications, and peak solder temperature.

(4) There may be additional marking, which relates to the logo, the lot trace code information, or the environmental category on the device.

(5) Multiple Device Markings will be inside parentheses. Only one Device Marking contained in parentheses and separated by a "-" will appear on a device. If a line is indented then it is a continuation of the previous line and the two combined represent the entire Device Marking for that device.

(6) Lead finish/Ball material - Orderable Devices may have multiple material finish options. Finish options are separated by a vertical ruled line. Lead finish/Ball material values may wrap to two lines if the finish value exceeds the maximum column width.

Important Information and Disclaimer:The information provided on this page represents TI's knowledge and belief as of the date that it is provided. TI bases its knowledge and belief on information provided by third parties, and makes no representation or warranty as to the accuracy of such information. Efforts are underway to better integrate information from third parties. TI has taken and

continues to take reasonable steps to provide representative and accurate information but may not have conducted destructive testing or chemical analysis on incoming materials and chemicals. TI and TI suppliers consider certain information to be proprietary, and thus CAS numbers and other limited information may not be available for release.

In no event shall TI's liability arising out of such information exceed the total purchase price of the TI part(s) at issue in this document sold by TI to Customer on an annual basis.

TAPE AND REEL INFORMATION

QUADRANT ASSIGNMENTS FOR PIN 1 ORIENTATION IN TAPE

*All dimensions are nominal

Device	Package Type	Package Drawing	Pins	SPQ	Reel Diameter (mm)	Reel Width W1 (mm)	A0 (mm)	B0 (mm)	K0 (mm)	P1 (mm)	W (mm)	Pin1 Quadrant
SN65HVD3080EDGSR	VSSOP	DGS	10	2500	330.0	12.4	5.3	3.4	1.4	8.0	12.0	Q1
SN65HVD3083EDGSR	VSSOP	DGS	10	2500	330.0	12.4	5.3	3.4	1.4	8.0	12.0	Q1
SN65HVD3086EDGSR	VSSOP	DGS	10	2500	330.0	12.4	5.3	3.4	1.4	8.0	12.0	Q1
SN65HVD3086EDR	SOIC	D	14	2500	330.0	16.4	6.5	9.0	2.1	8.0	16.0	Q1

TAPE AND REEL BOX DIMENSIONS



*All dimensions are nominal

Device	Package Type	Package Drawing	Pins	SPQ	Length (mm)	Width (mm)	Height (mm)
SN65HVD3080EDGSR	VSSOP	DGS	10	2500	366.0	364.0	50.0
SN65HVD3083EDGSR	VSSOP	DGS	10	2500	366.0	364.0	50.0
SN65HVD3086EDGSR	VSSOP	DGS	10	2500	366.0	364.0	50.0
SN65HVD3086EDR	SOIC	D	14	2500	356.0	356.0	35.0

DGS0010A



PACKAGE OUTLINE

VSSOP - 1.1 mm max height

SMALL OUTLINE PACKAGE



4221984/A 05/2015

NOTES:

1. All linear dimensions are in millimeters. Any dimensions in parenthesis are for reference only. Dimensioning and tolerancing per ASME Y14.5M.
2. This drawing is subject to change without notice.
3. This dimension does not include mold flash, protrusions, or gate burrs. Mold flash, protrusions, or gate burrs shall not exceed 0.15 mm per side.
4. This dimension does not include interlead flash. Interlead flash shall not exceed 0.25 mm per side.
5. Reference JEDEC registration MO-187, variation BA.

EXAMPLE BOARD LAYOUT

DGS0010A

VSSOP - 1.1 mm max height

SMALL OUTLINE PACKAGE



LAND PATTERN EXAMPLE
SCALE:10X



SOLDER MASK DETAILS
NOT TO SCALE

4221984/A 05/2015

NOTES: (continued)

- 6. Publication IPC-7351 may have alternate designs.
- 7. Solder mask tolerances between and around signal pads can vary based on board fabrication site.

EXAMPLE STENCIL DESIGN

DGS0010A

VSSOP - 1.1 mm max height

SMALL OUTLINE PACKAGE



SOLDER PASTE EXAMPLE
BASED ON 0.125 mm THICK STENCIL
SCALE:10X

4221984/A 05/2015

NOTES: (continued)

8. Laser cutting apertures with trapezoidal walls and rounded corners may offer better paste release. IPC-7525 may have alternate design recommendations.
9. Board assembly site may have different recommendations for stencil design.

D (R-PDSO-G14)

PLASTIC SMALL OUTLINE



- NOTES:
- All linear dimensions are in millimeters.
 - This drawing is subject to change without notice.
 - Publication IPC-7351 is recommended for alternate designs.
 - Laser cutting apertures with trapezoidal walls and also rounding corners will offer better paste release. Customers should contact their board assembly site for stencil design recommendations. Refer to IPC-7525 for other stencil recommendations.
 - Customers should contact their board fabrication site for solder mask tolerances between and around signal pads.

IMPORTANT NOTICE AND DISCLAIMER

TI PROVIDES TECHNICAL AND RELIABILITY DATA (INCLUDING DATA SHEETS), DESIGN RESOURCES (INCLUDING REFERENCE DESIGNS), APPLICATION OR OTHER DESIGN ADVICE, WEB TOOLS, SAFETY INFORMATION, AND OTHER RESOURCES "AS IS" AND WITH ALL FAULTS, AND DISCLAIMS ALL WARRANTIES, EXPRESS AND IMPLIED, INCLUDING WITHOUT LIMITATION ANY IMPLIED WARRANTIES OF MERCHANTABILITY, FITNESS FOR A PARTICULAR PURPOSE OR NON-INFRINGEMENT OF THIRD PARTY INTELLECTUAL PROPERTY RIGHTS.

These resources are intended for skilled developers designing with TI products. You are solely responsible for (1) selecting the appropriate TI products for your application, (2) designing, validating and testing your application, and (3) ensuring your application meets applicable standards, and any other safety, security, regulatory or other requirements.

These resources are subject to change without notice. TI grants you permission to use these resources only for development of an application that uses the TI products described in the resource. Other reproduction and display of these resources is prohibited. No license is granted to any other TI intellectual property right or to any third party intellectual property right. TI disclaims responsibility for, and you will fully indemnify TI and its representatives against, any claims, damages, costs, losses, and liabilities arising out of your use of these resources.

TI's products are provided subject to [TI's Terms of Sale](#) or other applicable terms available either on [ti.com](https://www.ti.com) or provided in conjunction with such TI products. TI's provision of these resources does not expand or otherwise alter TI's applicable warranties or warranty disclaimers for TI products.

TI objects to and rejects any additional or different terms you may have proposed.

Mailing Address: Texas Instruments, Post Office Box 655303, Dallas, Texas 75265
Copyright © 2024, Texas Instruments Incorporated

Looking for pricing, stock, or lifecycle information?

Click below to explore more details on WIN SOURCE:

 [View SN65HVD3083EDGSG4 on WIN SOURCE](#)

 [Texas Instruments](#) Information

Optimize Your Supply Chain with WIN SOURCE Solutions

-  Global Sourcing Solution
-  Obsolete Management
-  Cost Control Management
-  Shortage Management
-  Alternative Solution
-  Excess Inventory Management