



**THE DATASHEET OF
CD74ACT164M**



CDx4AC164, CDx4ACT164 8-Bit Serial-In/Parallel-Out Shift Register

1 Features

- Buffered Inputs
- Typical Propagation Delay
 - 6ns at $V_{CC} = 5V$, $T_A = 25^\circ C$, $C_L = 50pF$
- SCR-Latchup-Resistant CMOS Process and Circuit Design
- Speed of Bipolar FAST™/AS/S with Significantly Reduced Power Consumption
- Balanced Propagation Delays
- AC Types Feature 1.5V to 5.5V Operation and Balanced Noise Immunity at 30% of the Supply
- $\pm 24mA$ Output Drive Current
 - Fanout to 15 FAST™ ICs
 - Drives 50 Ω Transmission Lines

2 Description

The 'AC164 and 'ACT164 are 8-bit serial-in/parallel-out shift registers with asynchronous reset that utilize Advanced CMOS Logic technology.

Device Information

| PART NUMBER | PACKAGE ⁽¹⁾ | PACKAGE SIZE ⁽²⁾ | BODY SIZE ⁽³⁾ |
|--------------|------------------------|-----------------------------|--------------------------|
| CDx4AC(T)164 | D (SOIC, 14) | 8.65mm × 6mm | 8.65mm × 3.9mm |
| | N (PDIP, 14) | 19.3mm × 9.4mm | 19.3mm × 6.35mm |

- (1) For more information, see [Section 10](#).
- (2) The package size (length × width) is a nominal value and includes pins, where applicable.
- (3) The body size (length × width) is a nominal value and does not include pins.

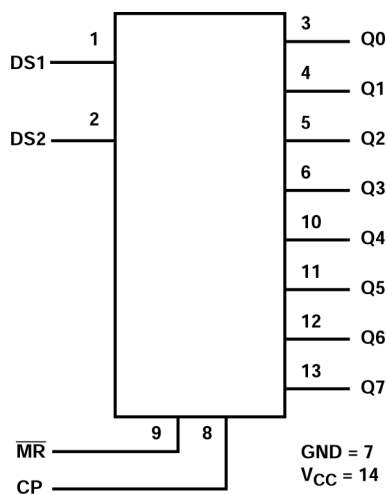

Functional Diagram



Table of Contents

| | | | |
|--|---|--|----|
| 1 Features | 1 | 6.3 Device Functional Modes..... | 9 |
| 2 Description | 1 | 7 Application and Implementation | 10 |
| 3 Pin Configuration and Functions | 3 | 7.1 Power Supply Recommendations..... | 10 |
| 4 Specifications | 4 | 7.2 Layout..... | 10 |
| 4.1 Absolute Maximum Ratings..... | 4 | 8 Device and Documentation Support | 11 |
| 4.2 ESD Ratings..... | 4 | 8.1 Documentation Support (Analog)..... | 11 |
| 4.3 Recommended Operating Conditions..... | 4 | 8.2 Receiving Notification of Documentation Updates... | 11 |
| 4.4 Thermal Information..... | 4 | 8.3 Support Resources..... | 11 |
| 4.5 DC Electrical Specifications..... | 5 | 8.4 Trademarks..... | 11 |
| 4.6 Prerequisite for Switching Function..... | 6 | 8.5 Electrostatic Discharge Caution..... | 11 |
| 4.7 Switching Specifications..... | 7 | 8.6 Glossary..... | 11 |
| 5 Parameter Measurement Information | 8 | 9 Revision History | 11 |
| 6 Detailed Description | 9 | 10 Mechanical, Packaging, and Orderable Information | 12 |
| 6.1 Overview..... | 9 | | |
| 6.2 Functional Block Diagram..... | 9 | | |

3 Pin Configuration and Functions

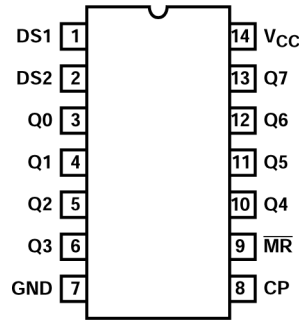

Figure 3-1. CD54AC164, CD54ACT164 J Package, 14-Pin Cerdip; CD74AC164, CD74ACT164 D or N Package, 14-Pin SOIC or PDIP (Top View)

Table 3-1. Pin Functions

| NAME | PIN | TYPE | DESCRIPTION |
|-----------------|-----|------|----------------|
| DS1 | 1 | I | Serial input 1 |
| DS2 | 2 | I | Serial input 2 |
| Q0 | 3 | O | Output 0 |
| Q1 | 4 | O | Output 1 |
| Q2 | 5 | O | Output 2 |
| Q3 | 6 | O | Output 3 |
| GND | 7 | G | Ground |
| CP | 8 | I | Clock signal |
| MR | 9 | I | Master reset |
| Q4 | 10 | O | Output 4 |
| Q5 | 11 | O | Output 5 |
| Q6 | 12 | O | Output 6 |
| Q7 | 13 | O | Output 7 |
| V _{CC} | 14 | P | Power |

4 Specifications

4.1 Absolute Maximum Ratings

over operating free-air temperature range (unless otherwise noted)⁽¹⁾

| | | MIN | MAX | UNIT |
|--|---|---|------|------|
| V _{CC} | DC Supply Voltage | -0.5 | 6 | V |
| I _{IK} | DC Input Diode Current | (V _I < -0.5V or V _I > V _{CC} + 0.5V) | ± 20 | mA |
| I _{OK} | DC Output Diode Current | (V _O < -0.5V or V _O > V _{CC} + 0.5V) | ±50 | mA |
| I _O | DC Output Source or Sink Current per Output Pin | (V _O > -0.5V or V _O < V _{CC} + 0.5V) | ±50 | mA |
| I _{CC} or I _{GND} ⁽²⁾ | DC V _{CC} or Ground Current | | ±100 | mA |

- (1) Stresses above those listed in “Absolute Maximum Ratings” may cause permanent damage to the device. This is a stress only rating and operation of the device at these or any other conditions above those indicated in the operational sections of this specification is not implied.
- (2) For up to 4 outputs per device, add ±25mA for each additional output.

4.2 ESD Ratings

| | | VALUE | UNIT |
|--------------------|-------------------------|---|------------|
| V _(ESD) | Electrostatic discharge | Human-body model (HBM), per ANSI/ESDA/JEDEC JS-001 ⁽¹⁾ | ±2000 V |

- (1) JEDEC document JEP155 states that 500-V HBM allows safe manufacturing with a standard ESD control process.

4.3 Recommended Operating Conditions

over operating free-air temperature range (unless otherwise noted)

| | | MIN | MAX | UNIT |
|---------------------------------|----------------------------|--------------|-----------------|------|
| T _A | Temperature Range | -55 | 125 | °C |
| Supply Voltage Range | | | | |
| V _{CC} ⁽¹⁾ | AC Types | 1.5 | 5.5 | V |
| | ACT Types | 4.5 | 5.5 | V |
| V _I , V _O | DC Input or Output Voltage | 0 | V _{CC} | V |
| Input Rise and Fall Slew Rate | | | | |
| dt/dv | AC Types | 1.5V to 3V | 50 | ns |
| | AC Types | 3.6V to 5.5V | 20 | ns |
| | ACT Types | 4.5V to 5.5V | 10 | ns |

- (1) Unless otherwise specified, all voltages are referenced to ground.

4.4 Thermal Information

| THERMAL METRIC ⁽¹⁾ | | CDx4AC(T)164 | | UNIT |
|-------------------------------|--|--------------|----------|------|
| | | N (PDIP) | D (SOIC) | |
| | | 14 PINS | 14 PINS | |
| R _{θJA} | Junction-to-ambient thermal resistance | 90 | 106.6 | °C/W |

- (1) θ_{JA} is measured with the component mounted on an evaluation PC board in free air.

4.5 DC Electrical Specifications

| PARAMETER | | TEST CONDITIONS | | V _{CC} (V) | 25°C | | -40°C TO 85 °C | | -55°C TO 125°C | | UNITS |
|-----------------|------------------------------|------------------------------------|---------------------|---------------------|------|------|----------------|------|----------------|------|-------|
| | | V _I (V) | I _O (mA) | | MIN | MAX | MIN | MAX | MIN | MAX | |
| AC TYPES | | | | | | | | | | | |
| V _{IH} | High Level Input Voltage | - | - | 1.5 | 1.2 | - | 1.2 | - | 1.2 | - | V |
| | | | | 3 | 2.1 | - | 2.1 | - | 2.1 | - | V |
| | | | | 5.5 | 3.85 | - | 3.85 | - | 3.85 | - | V |
| V _{IL} | Low Level Input Voltage | - | - | 1.5 | - | 0.3 | - | 0.3 | - | 0.3 | V |
| | | | | 3 | - | 0.9 | - | 0.9 | - | 0.9 | V |
| | | | | 5.5 | - | 1.65 | - | 1.65 | - | 1.65 | V |
| V _{OH} | High Level Output Voltage | V _{IH} or V _{IL} | -0.05 | 1.5 | 1.4 | - | 1.4 | - | 1.4 | - | V |
| | | | -0.05 | 3 | 2.9 | - | 2.9 | - | 2.9 | - | V |
| | | | -0.05 | 4.5 | 4.4 | - | 4.4 | - | 4.4 | - | V |
| | | | -4 | 3 | 2.58 | - | 2.48 | - | 2.4 | - | V |
| | | | -24 | 4.5 | 3.94 | - | 3.8 | - | 3.7 | - | V |
| | | | -75 (1) (2) | 5.5 | - | - | 3.85 | - | - | - | V |
| | | | -50 (1) (2) | 5.5 | - | - | - | - | 3.85 | - | V |
| V _{OL} | Low Level Output Voltage | V _{IH} or V _{IL} | 0.05 | 1.5 | - | 0.1 | - | 0.1 | - | 0.1 | V |
| | | | 0.05 | 3 | - | 0.1 | - | 0.1 | - | 0.1 | V |
| | | | 0.05 | 4.5 | - | 0.1 | - | 0.1 | - | 0.1 | V |
| | | | 12 | 3 | - | 0.36 | - | 0.44 | - | 0.5 | V |
| | | | 24 | 4.5 | - | 0.36 | - | 0.44 | - | 0.5 | V |
| | | | 75 (1) (2) | 5.5 | - | - | - | 1.65 | - | - | V |
| | | | 50 (1) (2) | 5.5 | - | - | - | - | - | 1.65 | V |
| I _I | Input Leakage Current | V _{CC} or GND | - | 5.5 | - | ±0.1 | - | ±1 | - | ±1 | µA |
| I _{CC} | Quiescent Supply Current MSI | V _{CC} or GND | 0 | 5.5 | - | 8 | - | 80 | - | 160 | µA |
| ACT TYPES | | | | | | | | | | | |
| V _{IH} | High Level Input Voltage | - | - | 4.5 to 5.5 | 2 | - | 2 | - | 2 | - | V |
| V _{IL} | Low Level Input Voltage | - | - | 4.5 to 5.5 | - | 0.8 | - | 0.8 | - | 0.8 | V |
| V _{OH} | High Level Output Voltage | V _{IH} or V _{IL} | -0.05 | 4.5 | 4.4 | - | 4.4 | - | 4.4 | - | V |
| | | | -24 | 4.5 | 3.94 | - | 3.8 | - | 3.7 | - | V |
| | | | -75 (1) (2) | 5.5 | - | - | 3.85 | - | - | - | V |
| | | | -50 (1) (2) | 5.5 | - | - | - | - | 3.85 | - | V |
| V _{OL} | Low Level Output Voltage | V _{IH} or V _{IL} | 0.05 | 4.5 | - | 0.1 | - | 0.1 | - | 0.1 | V |
| | | | 24 | 4.5 | - | 0.36 | - | 0.44 | - | 0.5 | V |
| | | | 75 (1) (2) | 5.5 | - | - | - | 1.65 | - | - | V |
| | | | 50 (1) (2) | 5.5 | - | - | - | - | - | 1.65 | V |
| I _I | Input Leakage Current | V _{CC} or GND | - | 5.5 | - | ±0.1 | - | ±1 | - | ±1 | µA |
| I _{CC} | Quiescent Supply Current MSI | V _{CC} or GND | 0 | 5.5 | - | 8 | - | 80 | - | 160 | µA |

| PARAMETER | | TEST CONDITIONS | | V _{CC} (V) | 25°C | | -40°C TO 85°C | | -55°C TO 125°C | | UNITS |
|------------------|---|----------------------|---------------------|---------------------|------|-----|---------------|-----|----------------|-----|-------|
| | | V _I (V) | I _O (mA) | | MIN | MAX | MIN | MAX | MIN | MAX | |
| ΔI _{CC} | Additional Supply Current per Input Pin TTL Inputs High 1 Unit Load | V _{CC} -2.1 | - | 4.5 to 5.5 | - | 2.4 | - | 2.8 | - | 3 | mA |

- (1) Test one output at a time for a 1-second maximum duration. Measurement is made by forcing current and measuring voltage to minimize power dissipation.
- (2) Test verifies a minimum 50Ω transmission-line-drive capability at 85°C, 75Ω at 125°C.

Table 4-1. ACT Input Load Table

| INPUT | UNIT LOAD |
|----------|-----------|
| DS1, DS2 | 0.5 |
| MR | 0.74 |
| CP | 0.71 |

Unit load is ΔI_{CC} limit specified in DC Electrical Specifications Table, e.g., 2.4mA max at 25°C.

4.6 Prerequisite for Switching Function

| PARAMETER | | V _{CC} (V) | -40°C TO 85°C | | -55°C TO 125°C | | UNITS |
|------------------|-----------------------|---------------------|---------------|-----|----------------|-----|-------|
| | | | MIN | MAX | MIN | MAX | |
| AC TYPES | | | | | | | |
| f _{MAX} | Max. Clock Frequency | 1.5 | 7 | - | 6 | - | MHz |
| | | 3.3 ⁽¹⁾ | 62 | - | 54 | - | MHz |
| | | 5 ⁽²⁾ | 86 | - | 75 | - | MHz |
| t _W | MR Pulse Width | 1.5 | 49 | - | 56 | - | ns |
| | | 3.3 | 5.5 | - | 6.3 | - | ns |
| | | 5 | 3.9 | - | 4.5 | - | ns |
| t _W | CP Pulse Width | 1.5 | 73 | - | 84 | - | ns |
| | | 3.3 | 8.2 | - | 9.4 | - | ns |
| | | 5 | 5.9 | - | 6.7 | - | ns |
| t _{SU} | Set-up Time | 1.5 | 27 | - | 31 | - | ns |
| | | 3.3 | 3.1 | - | 3.5 | - | ns |
| | | 5 | 2.2 | - | 2.5 | - | ns |
| t _H | Hold Time | 1.5 | 27 | - | 31 | - | ns |
| | | 3.3 | 3.1 | - | 3.5 | - | ns |
| | | 5 | 2.2 | - | 2.5 | - | ns |
| t _{REM} | MR to CP Removal Time | 1.5 | 1 | - | 1 | - | ns |
| | | 3.3 | 1 | - | 1 | - | ns |
| | | 5 | 1 | - | 1 | - | ns |
| ACT TYPES | | | | | | | |
| f _{MAX} | Max. Clock Frequency | 5 ⁽²⁾ | 80 | - | 70 | - | MHz |
| t _W | MR Pulse Width | 5 | 3.9 | - | 4.5 | - | ns |
| t _W | CP Pulse Width | 5 | 6.2 | - | 7.1 | - | ns |
| t _{SU} | Set-up Time | 5 | 2.2 | - | 2.5 | - | ns |
| t _H | Hold Time | 5 | 2.6 | - | 3 | - | ns |
| t _{REM} | MR to CP Removal Time | 5 | 0 | - | 0 | - | ns |

- (1) 9. 3.3V Min at 3.6V, Max at 3V.
- (2) 10. 5V Min at 5.5V, Max at 4.5V.

4.7 Switching Specifications

Input t_r , $t_f = 3\text{ns}$, $C_L = 50\text{pF}$ (Worst Case)

| PARAMETER | V_{CC} (V) | -40°C TO 85°C | | | -55°C TO 125°C | | | UNIT |
|---|--------------------|---------------|-----|------|----------------|-----|------|------|
| | | MIN | TYP | MAX | MIN | TYP | MAX | |
| AC TYPES | | | | | | | | |
| t_{PLH} , t_{PHL} Propagation Delay, CP to Qn | 1.5 | - | - | 143 | - | - | 157 | ns |
| | 3.3 ⁽¹⁾ | 4.5 | - | 15.9 | 4.4 | - | 17.5 | ns |
| | 5 ⁽²⁾ | 3.2 | - | 11.4 | 3.1 | - | 12.5 | ns |
| t_{PLH} , t_{PHL} Propagation Delay, \overline{MR} to Qn | 1.5 | - | - | 158 | - | - | 174 | ns |
| | 3.3 | 5 | - | 17.7 | 4.9 | - | 19.5 | ns |
| | 5 | 3.6 | - | 12.6 | 3.5 | - | 13.9 | ns |
| C_I Input Capacitance | - | - | - | 10 | - | - | 10 | pF |
| C_{PD} ⁽³⁾ Power Dissipation Capacitance | - | - | 150 | - | - | 150 | - | pF |
| ACT TYPES | | | | | | | | |
| t_{PLH} , t_{PHL} Propagation Delay, CP to Qn | 5 ⁽²⁾ | 3.8 | - | 13.5 | 3.7 | - | 14.9 | ns |
| t_{PLH} , t_{PHL} Propagation Delay, \overline{MR} to Qn | 5 | 4.1 | - | 14.4 | 4 | - | 15.8 | ns |
| C_I Input Capacitance | - | - | - | 10 | - | - | 10 | pF |
| C_{PD} ⁽³⁾ Power Dissipation Capacitance | - | - | 150 | - | - | 150 | - | pF |

- (1) 3.3V Min at 3.6V, Max at 3V.
 (2) 5V Min at 5.5V, Max at 4.5V.
 (3) C_{PD} is used to determine the dynamic power consumption per device.

5 Parameter Measurement Information

Load Circuit And Voltage Waveforms

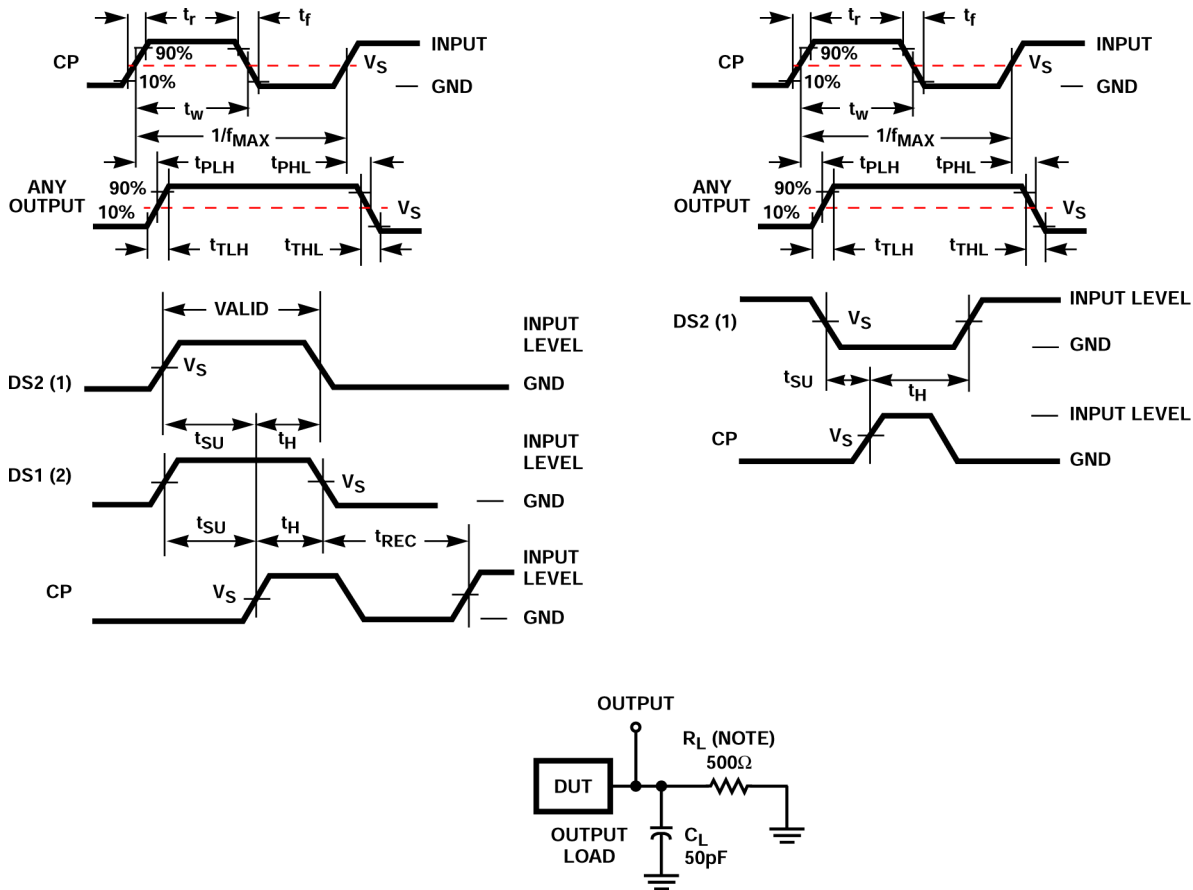

For AC Series Only: When VCC = 1.5V, RL = 1kΩ. For AC Series Only: When VCC = 1.5V, RL = 1kΩ. For AC Series Only: When VCC = 1.5V, RL = 1kΩ.

Figure 5-1. Propagation Delay Times

Table 5-1. Propagation Delay Times

| | AC | ACT |
|--|---------------------|---------------------|
| Input Level | V _{CC} | 3V |
| Input Switching Voltage, V _S | 0.5 V _{CC} | 1.5V |
| Output Switching Voltage, V _S | 0.5 V _{CC} | 0.5 V _{CC} |

6 Detailed Description

6.1 Overview

The 'AC164 and 'ACT164 are 8-bit serial-in/parallel-out shift registers with asynchronous reset that utilize Advanced CMOS Logic technology. Data is shifted on the positive edge of the clock (CP). A LOW on the Master Reset ($\overline{\text{MR}}$) pin resets the shift register and all outputs go to the LOW state regardless of the input conditions. Two Serial Data inputs (DS1 and DS2) are provided; either one can be used as a Data Enable control.

6.2 Functional Block Diagram

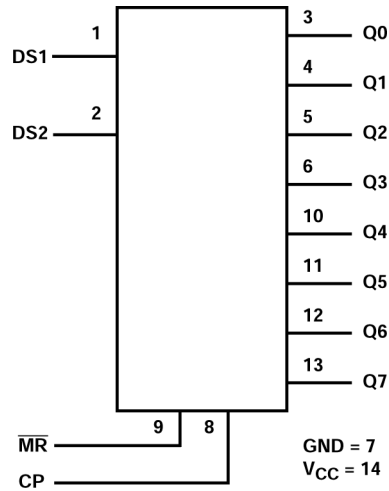

6.3 Device Functional Modes

Table 6-1. Mode Select - Truth Table

| OPERATING MODE | INPUTS | | | | OUTPUTS | |
|----------------|--------|----|-----|-----|---------|---------|
| | MR | CP | DS1 | DS2 | Q0 | Q1 - Q7 |
| RESET (CLEAR) | L | X | X | X | L | L - L |
| SHIFT | H | ↑ | l | l | L | q0 - q6 |
| | H | ↑ | l | h | L | q0 - q6 |
| | H | ↑ | h | l | L | q0 - q6 |
| | H | ↑ | h | h | H | q0 - q6 |

7 Application and Implementation

Note

Information in the following applications sections is not part of the TI component specification, and TI does not warrant its accuracy or completeness. TI's customers are responsible for determining suitability of components for their purposes, as well as validating and testing their design implementation to confirm system functionality.

7.1 Power Supply Recommendations

The power supply can be any voltage between the minimum and maximum supply voltage rating located in the *Recommended Operating Conditions*. Each V_{CC} terminal should have a good bypass capacitor to prevent power disturbance. A 0.1- μF capacitor is recommended for this device. It is acceptable to parallel multiple bypass capacitors to reject different frequencies of noise. The 0.1- μF and 1- μF capacitors are commonly used in parallel. The bypass capacitor should be installed as close to the power terminal as possible for best results, as shown in the following layout example.

7.2 Layout

7.2.1 Layout Guidelines

When using multiple-input and multiple-channel logic devices, inputs must never be left floating. In many cases, functions or parts of functions of digital logic devices are unused (for example, when only two inputs of a triple-input AND gate are used or only 3 of the 4 buffer gates are used). Such unused input pins must not be left unconnected because the undefined voltages at the outside connections result in undefined operational states. All unused inputs of digital logic devices must be connected to a logic high or logic low voltage, as defined by the input voltage specifications, to prevent them from floating. The logic level that must be applied to any particular unused input depends on the function of the device. Generally, the inputs are tied to GND or V_{CC} , whichever makes more sense for the logic function or is more convenient.

8 Device and Documentation Support

TI offers an extensive line of development tools. Tools and software to evaluate the performance of the device, generate code, and develop solutions are listed below.

8.1 Documentation Support (Analog)

8.1.1 Related Documentation

The table below lists quick access links. Categories include technical documents, support and community resources, tools and software, and quick access to sample or buy.

Table 8-1. Related Links

| PARTS | PRODUCT FOLDER | SAMPLE & BUY | TECHNICAL DOCUMENTS | TOOLS & SOFTWARE | SUPPORT & COMMUNITY |
|------------|----------------------------|----------------------------|----------------------------|----------------------------|----------------------------|
| CD54AC164 | Click here | Click here | Click here | Click here | Click here |
| CD74AC164 | Click here | Click here | Click here | Click here | Click here |
| CD54ACT164 | Click here | Click here | Click here | Click here | Click here |
| CD74ACT164 | Click here | Click here | Click here | Click here | Click here |

8.2 Receiving Notification of Documentation Updates

To receive notification of documentation updates, navigate to the device product folder on [ti.com](#). Click on *Notifications* to register and receive a weekly digest of any product information that has changed. For change details, review the revision history included in any revised document.

8.3 Support Resources

[TI E2E™ support forums](#) are an engineer's go-to source for fast, verified answers and design help — straight from the experts. Search existing answers or ask your own question to get the quick design help you need.

Linked content is provided "AS IS" by the respective contributors. They do not constitute TI specifications and do not necessarily reflect TI's views; see TI's [Terms of Use](#).

8.4 Trademarks

TI E2E™ is a trademark of Texas Instruments.
All trademarks are the property of their respective owners.

8.5 Electrostatic Discharge Caution



This integrated circuit can be damaged by ESD. Texas Instruments recommends that all integrated circuits be handled with appropriate precautions. Failure to observe proper handling and installation procedures can cause damage.

ESD damage can range from subtle performance degradation to complete device failure. Precision integrated circuits may be more susceptible to damage because very small parametric changes could cause the device not to meet its published specifications.

8.6 Glossary

[TI Glossary](#) This glossary lists and explains terms, acronyms, and definitions.

9 Revision History

NOTE: Page numbers for previous revisions may differ from page numbers in the current version.

| Changes from Revision B (November 2023) to Revision C (April 2024) | Page |
|--|------|
| • Updated RθJA values: D = 175 to 106.6, all values in °C/W | 4 |

Changes from Revision A (November 1998) to Revision B (November 2023) **Page**

- Added *Features* section; *Device Information* table, *Pin Functions* table, *ESD Ratings* table, *Thermal Information* table, *Device Functional Modes*, *Application and Implementation* section, *Device and Documentation Support* section, and *Mechanical, Packaging, and Orderable Information* section 1
-

10 Mechanical, Packaging, and Orderable Information

The following pages include mechanical, packaging, and orderable information. This information is the most current data available for the designated devices. This data is subject to change without notice and revision of this document. For browser-based versions of this data sheet, refer to the left-hand navigation.

IMPORTANT NOTICE AND DISCLAIMER

TI PROVIDES TECHNICAL AND RELIABILITY DATA (INCLUDING DATA SHEETS), DESIGN RESOURCES (INCLUDING REFERENCE DESIGNS), APPLICATION OR OTHER DESIGN ADVICE, WEB TOOLS, SAFETY INFORMATION, AND OTHER RESOURCES "AS IS" AND WITH ALL FAULTS, AND DISCLAIMS ALL WARRANTIES, EXPRESS AND IMPLIED, INCLUDING WITHOUT LIMITATION ANY IMPLIED WARRANTIES OF MERCHANTABILITY, FITNESS FOR A PARTICULAR PURPOSE OR NON-INFRINGEMENT OF THIRD PARTY INTELLECTUAL PROPERTY RIGHTS.

These resources are intended for skilled developers designing with TI products. You are solely responsible for (1) selecting the appropriate TI products for your application, (2) designing, validating and testing your application, and (3) ensuring your application meets applicable standards, and any other safety, security, regulatory or other requirements.

These resources are subject to change without notice. TI grants you permission to use these resources only for development of an application that uses the TI products described in the resource. Other reproduction and display of these resources is prohibited. No license is granted to any other TI intellectual property right or to any third party intellectual property right. TI disclaims responsibility for, and you will fully indemnify TI and its representatives against, any claims, damages, costs, losses, and liabilities arising out of your use of these resources.

TI's products are provided subject to [TI's Terms of Sale](#) or other applicable terms available either on [ti.com](https://www.ti.com) or provided in conjunction with such TI products. TI's provision of these resources does not expand or otherwise alter TI's applicable warranties or warranty disclaimers for TI products.

TI objects to and rejects any additional or different terms you may have proposed.

Mailing Address: Texas Instruments, Post Office Box 655303, Dallas, Texas 75265
Copyright © 2024, Texas Instruments Incorporated

Looking for pricing, stock, or lifecycle information?

Click below to explore more details on WIN SOURCE:

 [View CD74ACT164M on WIN SOURCE](#)

 [Texas Instruments](#) Information

Optimize Your Supply Chain with WIN SOURCE Solutions

-  Global Sourcing Solution
-  Obsolete Management
-  Cost Control Management
-  Shortage Management
-  Alternative Solution
-  Excess Inventory Management