



THE DATASHEET OF HMC1023



3-AXIS MAGNETIC SENSOR

Features

- Ball Grid Array (BGA) Surface-Mount Package
- Three Orthogonal Magneto-Resistive Sensors
- Wide Field Range of ± 6 Gauss
- 1.0 mV/V/gauss Sensitivity
- Minimum Detectable Field to $85\mu\text{gauss}$
- Patented On-Chip Set/Reset and Offset Straps

Product Description

The Honeywell HMC1023 is a high performance three-axis magneto-resistive sensor design in a single package. The advantages of the HMC1023 include orthogonal three-axis sensing, small size and a 16-contact BGA surface mount package.

Each of the magneto-resistive sensors are configured as 4-element Wheatstone bridges to convert magnetic fields to differential output voltages. Capable of sensing fields down to 85 micro-gauss, these sensors offer a compact, high sensitivity and highly reliable solution for low field magnetic sensing.

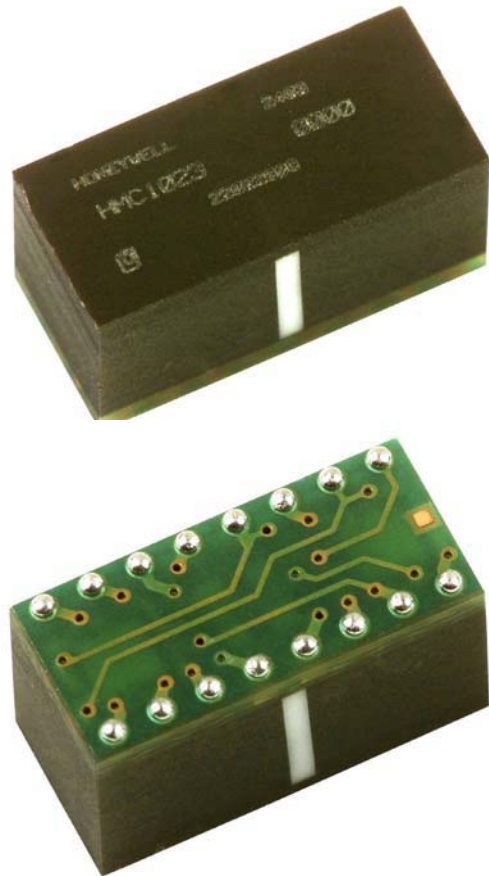

APPLICATIONS

- **Compassing**
- **Navigation Systems**
- **Attitude Reference**
- **Traffic Detection**
- **Medical Devices**

HMC1023 Circuit Diagram

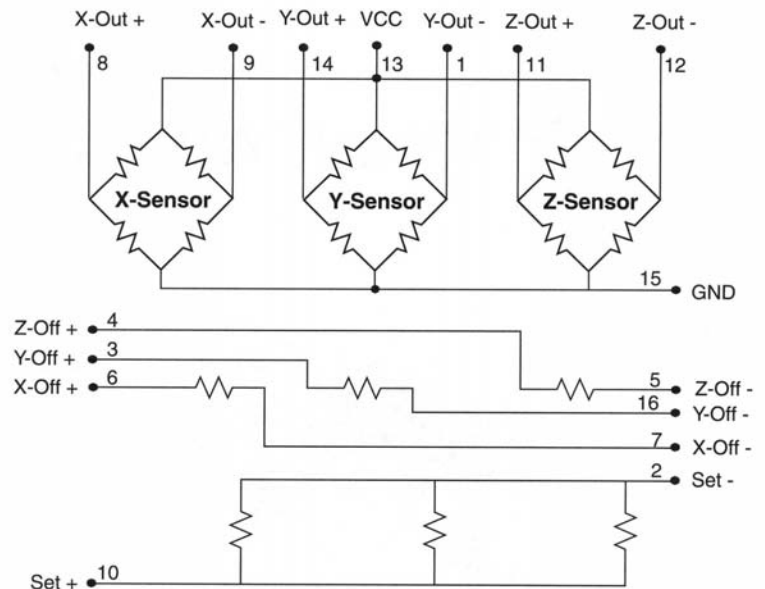

SPECIFICATIONS

Characteristics	Conditions*	Min	Typ	Max	Units
Bridge Elements					
Supply	V _{bridge} referenced to GND	1.8	5.0	12	Volts
Resistance	Bridge current = 5mA, VCC to GND	250	350	450	ohms
Operating Temperature	Ambient	-40		125	°C
Storage Temperature	Ambient, unbiased	-55		125	°C
Humidity	Tested at 121°C			100	%
Field Range	Full scale (FS) – total applied field	-6		+6	gauss
Linearity Error	Best fit straight line ± 1 gauss ± 3 gauss ± 6 gauss		0.05 0.4 1.6		%FS
Hysteresis Error	3 sweeps across ±3 gauss		0.08		%FS
Repeatability Error	3 sweeps across ±3 gauss		0.08		%FS
Bridge Offset	Offset = (OUT+) – (OUT-) Field = 0 gauss after Set pulse, VCC = 5V	-10	±2.5	+10	mV
Sensitivity	Set/Reset Current = 2.0A	0.8	1.0	1.2	mV/V/gauss
Noise Density	@ 1kHz, VCC=5V		48		nV/sqrt Hz
Resolution	50Hz Bandwidth, VCC=5V		85		μgauss
Bandwidth	Magnetic signal (lower limit = DC)		5		MHz
Disturbing Field	Sensitivity starts to degrade. Use S/R pulse to restore sensitivity.	20			gauss
Sensitivity Tempco	T _A = -40 to 125°C, VCC=5V T _A = -40 to 125°C, ICC=5mA	-2800	-3000 -600	-3200	ppm/°C
Bridge Offset Tempco	T _A = -40 to 125°C, No Set/Reset T _A = -40 to 125°C, With Set/Reset		±500 ±10		ppm/°C
Bridge Ohmic Tempco	VCC=5V, T _A = -40 to 125°C	2100	2500	2900	ppm/°C
Cross-Axis Effect	Cross field = 1 gauss, H _{applied} = ±1 gauss		+0.3		%FS
Max. Exposed Field	No perming effect on zero reading			200	gauss
Sensitivity Ratio of X,Y,Z Sensors	T _A = -40 to 125°C		100±5		%
X,Y, Z sensor Orthogonality	Sensitive direction in X, Y and Z sensors			1.0	degree

* Tested at 25°C except stated otherwise.

SPECIFICATIONS

Characteristics	Conditions*	Min	Typ	Max	Units
Set/Reset Strap					
Resistance	Measured from S/R+ to S/R-	2.0	3.0	4.0	ohms
Current	0.1% duty cycle, or less, 2μsec current pulse	1.5	2.0	4.0	Amp
Resistance Tempco	T _A = -40 to 125°C	3300	3700	4100	ppm/°C

Offset Straps

Resistance	Measured from OFFSET+ to OFFSET-	40	50	60	ohms
Offset Constant	DC Current Field applied in sensitive direction	4.0	4.6	6.0	mA/gauss
Resistance Tempco	T _A = -40 to 125°C	3500	3900	4300	ppm/°C

* Tested at 25°C except stated otherwise.

Pin Configuration

(Arrows indicate direction of applied field that generates a positive output voltage after a SET pulse.)

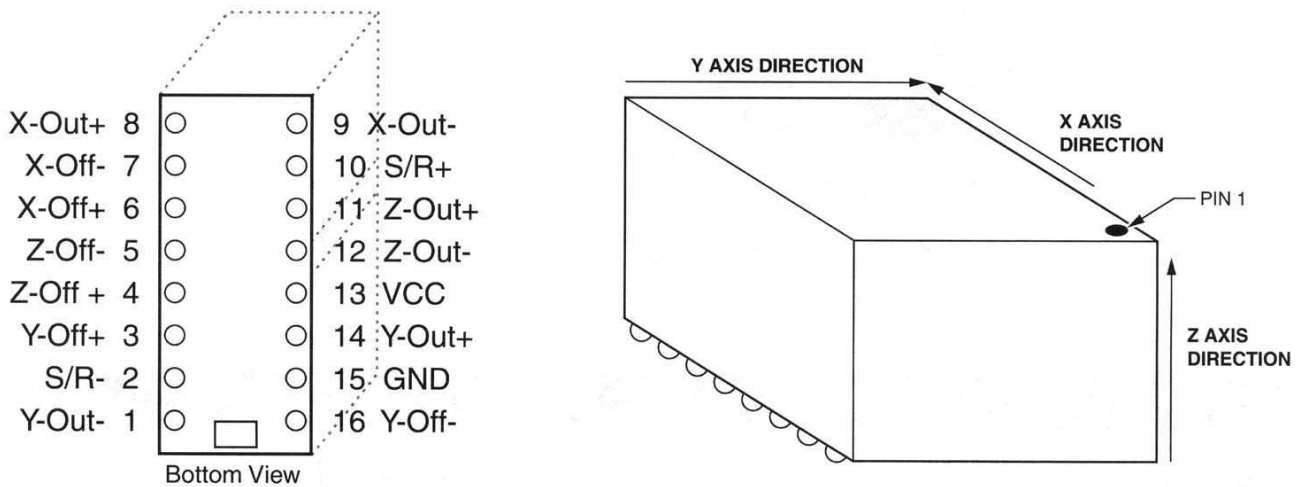

Package Outline

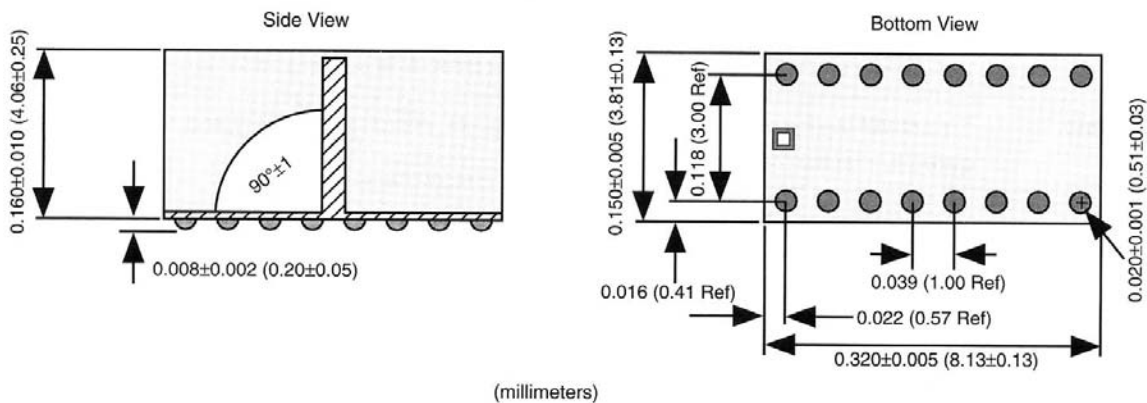

Mounting Considerations

When mounting the Honeywell HMC1023 on a circuit board, please consider the following advice for ball grid array component attachment.

Ball Grid Array attachment/removal to printed circuit boards is precisely controlled thermal solder reflow process. To prevent internal electrical damage and package cracking, do not use conventional soldering iron/solder station tools. If you do not have experience and the reflow oven, please have a qualified BGA rework technician do the work for you.

The reflow profile show below is the recommended profile for HMC1023 package attachment.

Kester Reflow Profile Alloy: Sn63Pb37 or Sn62Pb36Ag02

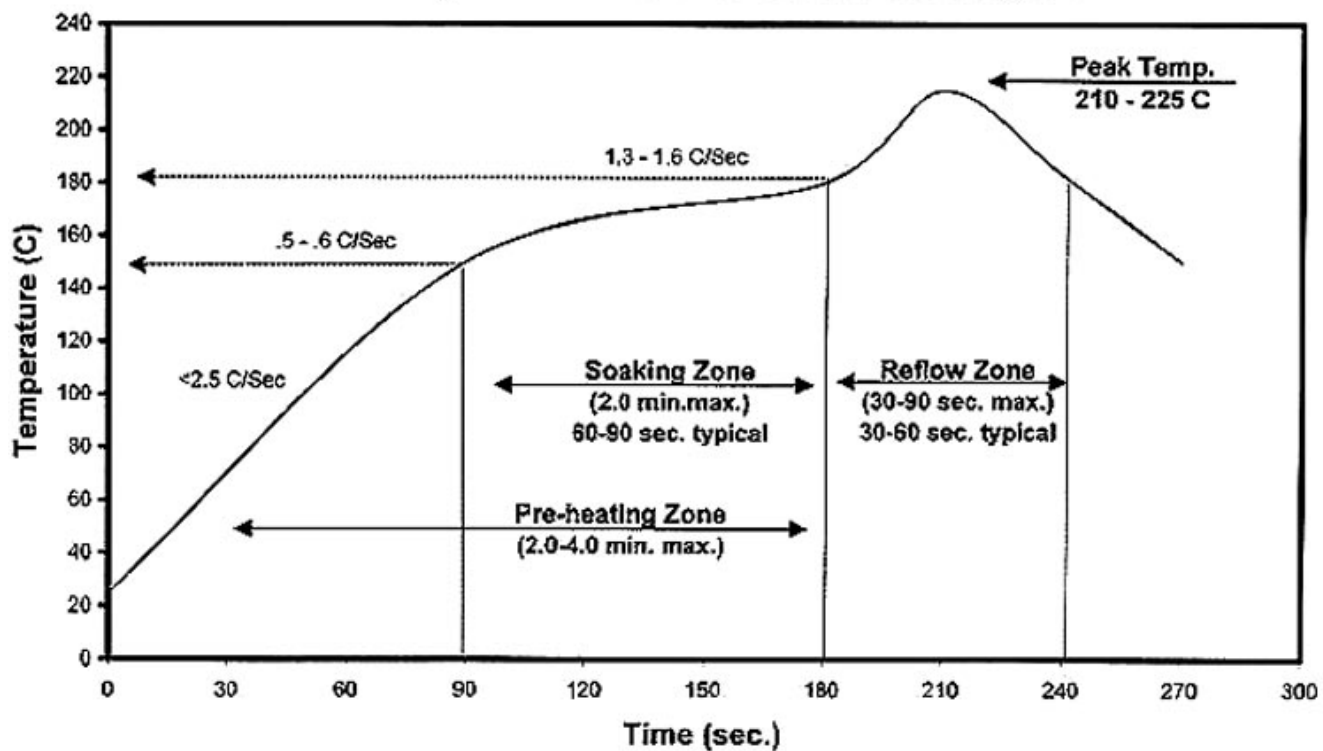

Melting temperature for the HMC1023 balls is at 180°C. The recommended rise and fall temperatures should be no greater than 3°C/sec to prevent mechanical stresses or “popcorning”. Peak external temperature the part should be exposed to is between 200 to 210°C. When exposed a high temperature, such as the solder reflow process, the internal connections in the package could sustain permanent damage, leaving open connections. 225°C is the melting point of solder inside the HMC1023 Ball Grid Array package. Do not expose the part to this level of temperature.

If using solder paste, we recommend Kester SN62 solder paste with water soluble flux R560. This has a melting point around 180°C. Kester recommends a pre-heating zone from ambient temperature to 180°C for 2 to 4 minutes maximum. The first part of this pre-heating zone ramps up from ambient to 150°C in 90 seconds with a ramp rate of less than 2.5 degrees C per second. The soak zone should last from 60 to 90 seconds (2 minutes maximum) and ramp up in temperature from 150 to 180°C at 0.5 to 0.6 °C/ sec. The reflow zone should last for 30 to 90 seconds maximum (40 to 60 seconds is ideal) and peak in temperature between 200 and 210°C with a ramp of 1.3 to 1.6°C/sec.

The reflow parameters can vary significantly and excellent reflow results can still be achieved. A thin layer of paste flux or a 2 to 3 mil layer of solder paste applied to the mother-board prior to placing the HMC1023 is helpful. The profile can be verified by placing a thermocouple between the HMC1023 and motherboard.

Basic Device Operation

The Honeywell HMC1023 magneto-resistive sensor is composed of three Wheatstone bridge elements to measure magnetic fields for both field strength and direction. With power applied to the bridges, the sensors elements convert any incident magnetic field in each element's sensitive axis direction to a differential voltage output. In addition to the bridge elements, these sensors have two types of on-chip magnetically coupled straps; the offset straps and the set/reset strap. These straps are Honeywell patented features for incident field adjustment and magnetic domain alignment; and eliminate the need for external coils positioned around the sensors.

The magnetoresistive sensors are made of a nickel-iron (Permalloy) thin-film deposited on a silicon wafer and patterned as a resistive strip element. In the presence of a magnetic field, a change in the bridge resistive elements causes a corresponding change in voltage across the bridge outputs.

These resistive elements are aligned together to have a common sensitive axis (indicated by arrows on the pinouts) that will provide positive voltage change with magnetic fields increasing in the sensitive direction. Because the output only is in proportion to the one-dimensional axis (the principle of anisotropy) and its magnitude, additional sensor bridges placed at orthogonal directions permit accurate measurement of arbitrary field direction. The combination of sensor bridges in this three orthogonal axis configuration permit applications such as compassing and magnetometry.

The individual sensor offset straps allow for several modes of operation when a direct current is driven through it. These modes are: 1) Subtraction (bucking) of an unwanted external magnetic field, 2) null-ing of the bridge offset voltage, 3) Closed loop field cancellation, and 4) Auto-calibration of bridge gain.

The set/reset strap can be pulsed with high currents for the following benefits: 1) Enable the sensor to perform high sensitivity measurements, 2) Flip the polarity of the bridge output voltage, and 3) Periodically used to improve linearity, lower cross-axis effects, and temperature effects.

Noise Characteristics

The noise density for the HMR1023 series is around 50nV/sqrt Hz at the 1 Hz corner, and drops below 10nV/sqrt Hz at 20Hz and begins to fit the Johnson Noise value at around 5nV/sqrt Hz beyond 100Hz. The 10Hz noise voltage averages around 0.58 micro-volts with a 0.16 micro-volts standard deviation. These values are provided with a 5-volt supply.

Offset Strap

The offset strap is a spiral of metalization that couples in the sensor element's sensitive axis. In the HMC1023 design, there is one strap per bridge with both ends brought out externally. Each offset strap measures nominally 50 ohms, and requires about 4.6mA for each gauss of induced field. The straps will easily handle currents to buck or boost fields through the ± 6 gauss linear measurement range, but designers should note the extreme thermal heating on the sensor die when doing so.

With most applications, the offset strap is not utilized and can be ignored. Designers can leave one or both strap connections (Off- and Off+) open circuited, or ground one connection node. Do not tie positive and negative strap connections together of the same strap to avoid shorted turn magnetic circuits.

Set/Reset Strap

The set/reset strap is another spiral of metalization that couples to the sensor elements easy axis (perpendicular to the sensitive axis on the sensor die). The HMC1023 set/reset strap circuit has three straps (one per sensor) paralleled together for operation at low voltages. The set/reset strap connections have a nominal resistance of 3.0 ohms with a minimum required peak current of 1.5A for reset or set pulses. With rare exception, the set/reset strap must be used to periodically condition the magnetic domains of the magneto-resistive elements for best and reliable performance.

A set pulse is defined as a positive pulse current entering the S/R+ strap connection. The successful result would be the magnetic domains aligned in a forward easy-axis direction so that the sensor bridge's polarity is a positive slope with positive fields on the sensitive axis result in positive voltages across the bridge output connections.

A reset pulse is defined as a negative pulse current entering the S/R+ strap connection. The successful result would be the magnetic domains aligned in a reverse easy-axis direction so that sensor bridge's polarity is a negative slope with positive fields on the sensitive axis result in negative voltages across the bridge output connections.

Typically a reset pulse is sent first, followed by a set pulse a few milliseconds later. By showing the magnetic domains in completely opposite directions, any prior magnetic disturbances are likely to be completely erased by the duet of pulses. For simpler circuits with less critical requirements for noise and accuracy, a single polarity pulse circuit may be employed (all sets or all resets). With these uni-polar pulses, several pulses together become close in performance to a set/reset pulse circuit. Figure 1 shows a quick and dirty manual pulse circuit for uni-polar application of pulses to the set/reset strap.

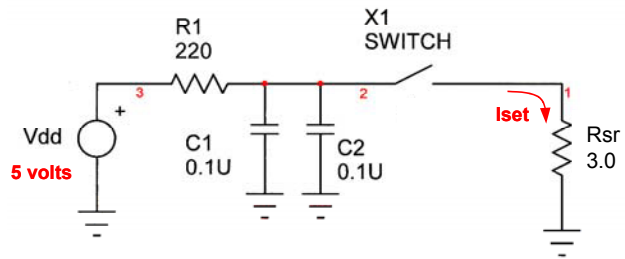

Figure 1
Set Pulse Circuit

Application Notes

Three Axis Compassing with Tilt Compensation

For full three-axis compassing, the circuit depicted in Figure 2 shows HMC1023 used for sensing the magnetic field in three axes. A two-axis accelerometer with digital (PWM) outputs is also shown to provide pitch and roll (tilt) sensing, to correct the three-axis magnetic sensors outputs into to the tilt-compensated two-axis heading. The accelerometer can be substituted with a fluidic 2-axis tilt sensor if desired. For lower voltage operation with Lithium battery supplies (2.5 to 3.6Vdc), the Set/Reset circuit should be upgraded from a single IRF7509 to the dual IRF7509 implementation (H-bridge) to permit a minimum 1.5-ampere pulse (500mA per set/reset strap resistance) to the sensors.

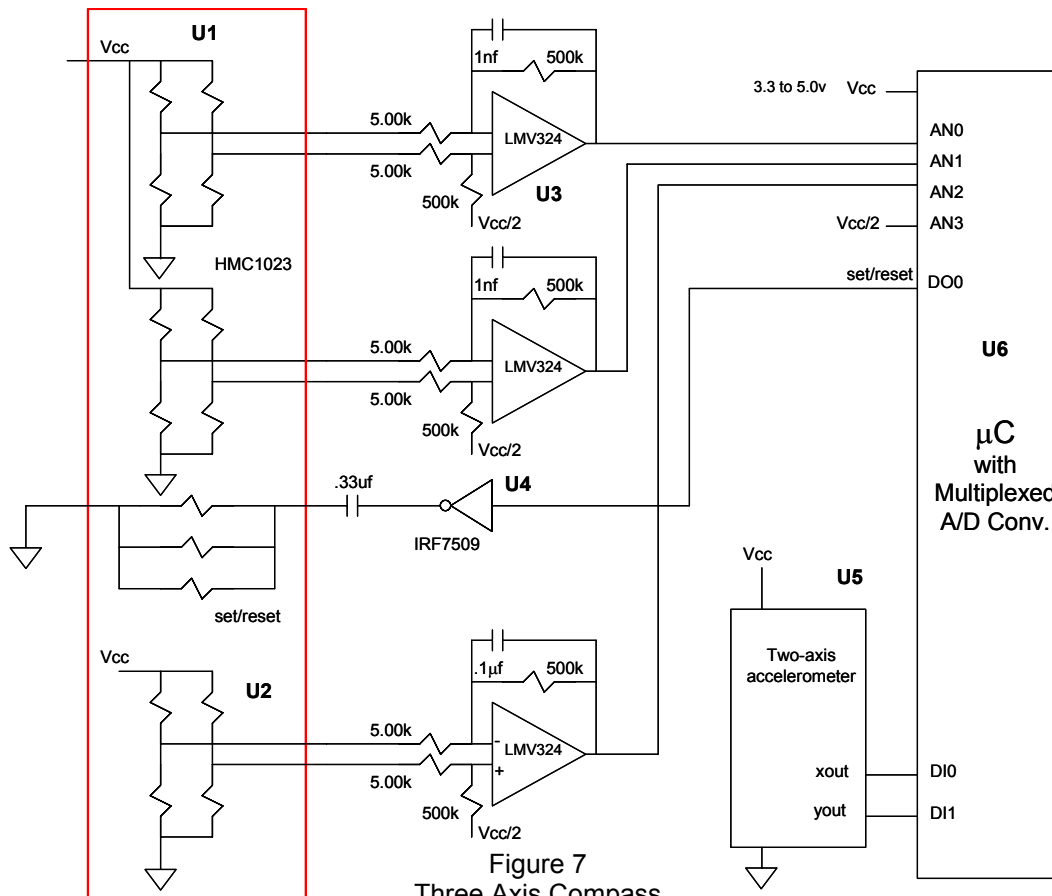

Figure 7
Three Axis Compass

Duty Cycling for Lower Energy Consumption

For battery powered and other applications needing limited energy consumption, the sensor bridge and support electronics can be switched “off” between magnetic field measurements. The HMC1023 sensors are very low capacitance (Bandwidth > 5MHz) sensor bridges and can stabilize quickly, typically before the support electronics can. Other energy saving ideas would be to minimize the quantity of set/reset pulses which saves energy over the battery life. Figure 3 shows a simple supply switching circuit that can be microprocessor controlled to duty cycle (toggle) the electronics in moderate current (<25mA) applications.

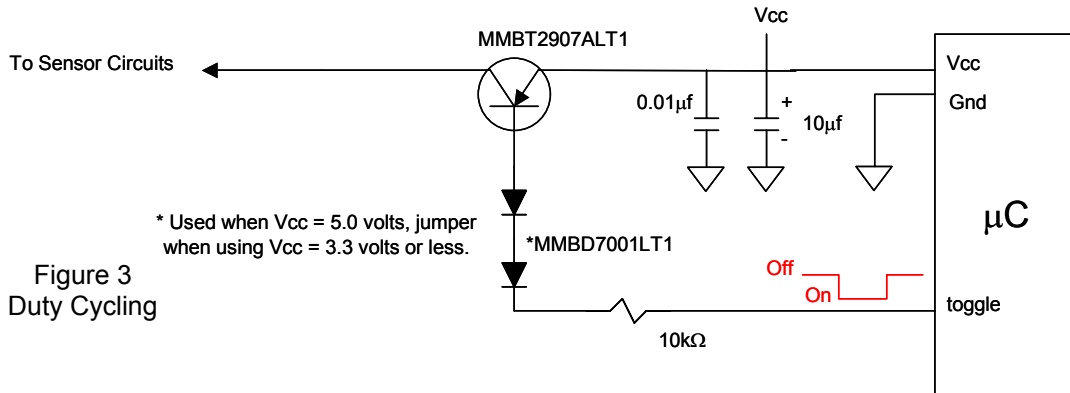

Figure 3
Duty Cycling

ORDERING INFORMATION

Part Number	Package Style
HMC1023	Three Axis Magnetic Sensor
HMC1023PCB	Three Axis Magnetic Sensor – 16-Pin DIP Demo

The application circuits herein constitute typical usage and interface of Honeywell product. Honeywell does not warrant or assume liability for customer-designed circuits derived from this description or depiction.

Honeywell reserves the right to make changes to improve reliability, function or design. Honeywell does not assume any liability arising out of the application or use of any product or circuit described herein; neither does it convey any license under its patent rights nor the rights of others.

This product may be covered by one or more of the following U.S. Patents: 4569742 4681812 4847584 4857418 4945397 5019461 5247278 5820924 5952825 and 6529114.

900252 10-03 Rev. B

Looking for pricing, stock, or lifecycle information?

Click below to explore more details on WIN SOURCE:

 [View HMC1023 on WIN SOURCE](#)

 [Honeywell Information](#)

Optimize Your Supply Chain with WIN SOURCE Solutions

-  Global Sourcing Solution
-  Obsolete Management
-  Cost Control Management
-  Shortage Management
-  Alternative Solution
-  Excess Inventory Management