



**THE DATASHEET OF  
AP34063N8L-U**



**Features**

- Operation from 3.0V to 40V Input
- Low Standby Current
- Current Limiting
- Output Switch Current to 1.6A
- Output Voltage Adjustable
- Frequency Operation to 100 kHz
- Precision 2% Reference
- Lead Free packages: SOP-8L and PDIP-8L (Note 1)
- SOP-8L: Available in "Green" Molding Compound (No Br, Sb)
- Lead Free Finish/RoHS Compliant (Note 2)

**Description**

The AP34063 Series is a monolithic control circuit containing the primary functions required for DC-to-DC converters. These devices consist of an internal temperature compensated reference, comparator, controlled duty cycle oscillator with an active current limit circuit, driver and high current output switch. This series is specifically designed for incorporating in Step-Down and Step-Up and Voltage-Inverting applications with a minimum number of external components.

**Application Circuit**

**(1) Step-Up Converter**

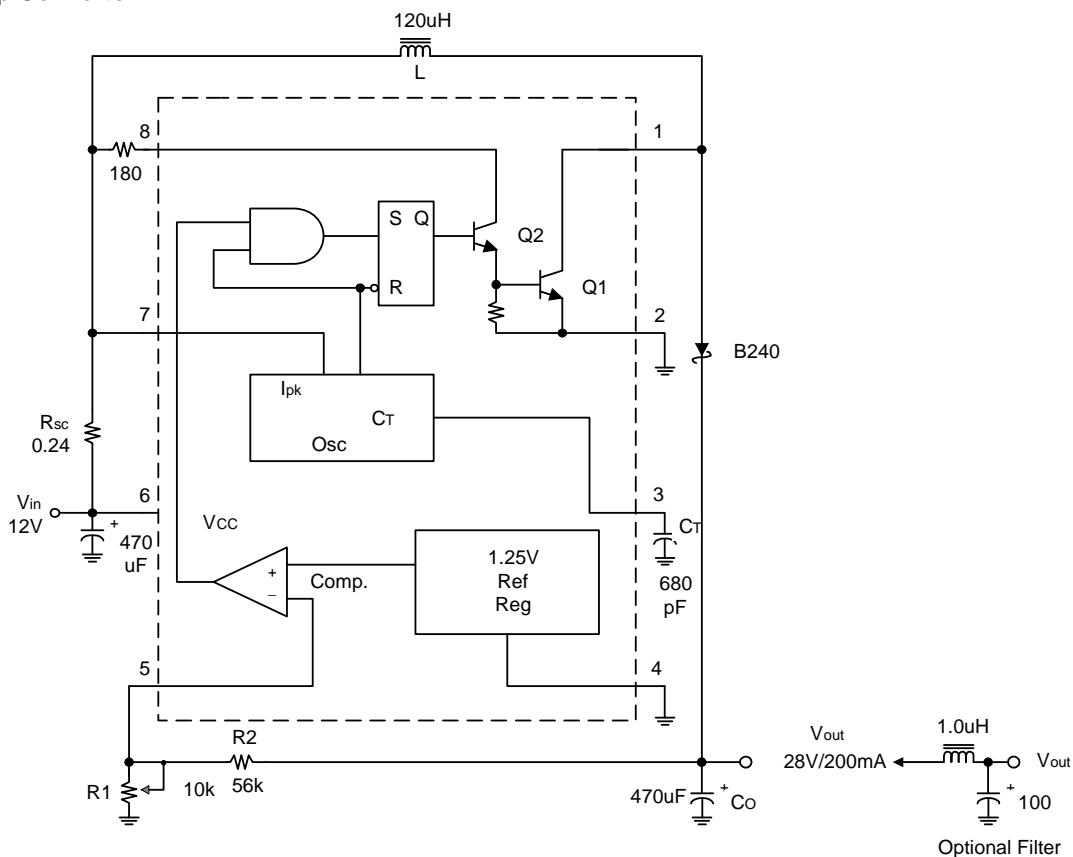

Test	Conditions	Results
Line Regulation	$V_{in} = 9V \text{ to } 12V, I_o = 200mA$	$20mV = \pm 0.035\%$
Load Regulation	$V_{in} = 12V, I_o = 50mA \text{ to } 200mA$	$15mV = \pm 0.035\%$
Output Ripple	$V_{in} = 12V, I_o = 200mA$	$500mV_{PP}$
Efficiency	$V_{in} = 12V, I_o = 200mA$	80%

**Application Circuit (Continued)**

**(2) Step-Down Converter**

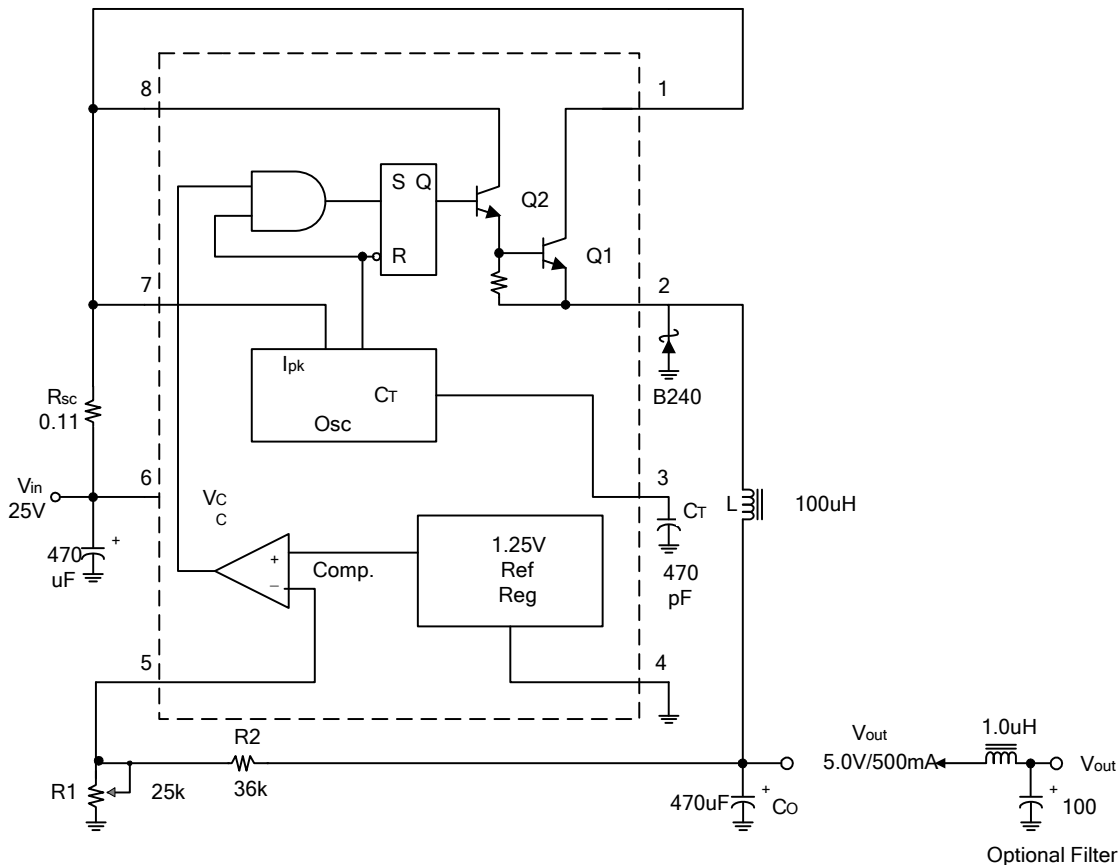

Test	Conditions	Results
Line Regulation	$V_{in} = 12V \text{ to } 24V, I_o = 500mA$	$20mV = \pm 0.2\%$
Load Regulation	$V_{in} = 24V, I_o = 50mA \text{ to } 500mA$	$5mV = \pm 0.05\%$
Output Ripple	$V_{in} = 24V, I_o = 500mA$	$160mV_{PP}$
Efficiency	$V_{in} = 24V, I_o = 500mA$	82%

**Application Circuit (Continued)**

**(3) Voltage Inverting Converter**

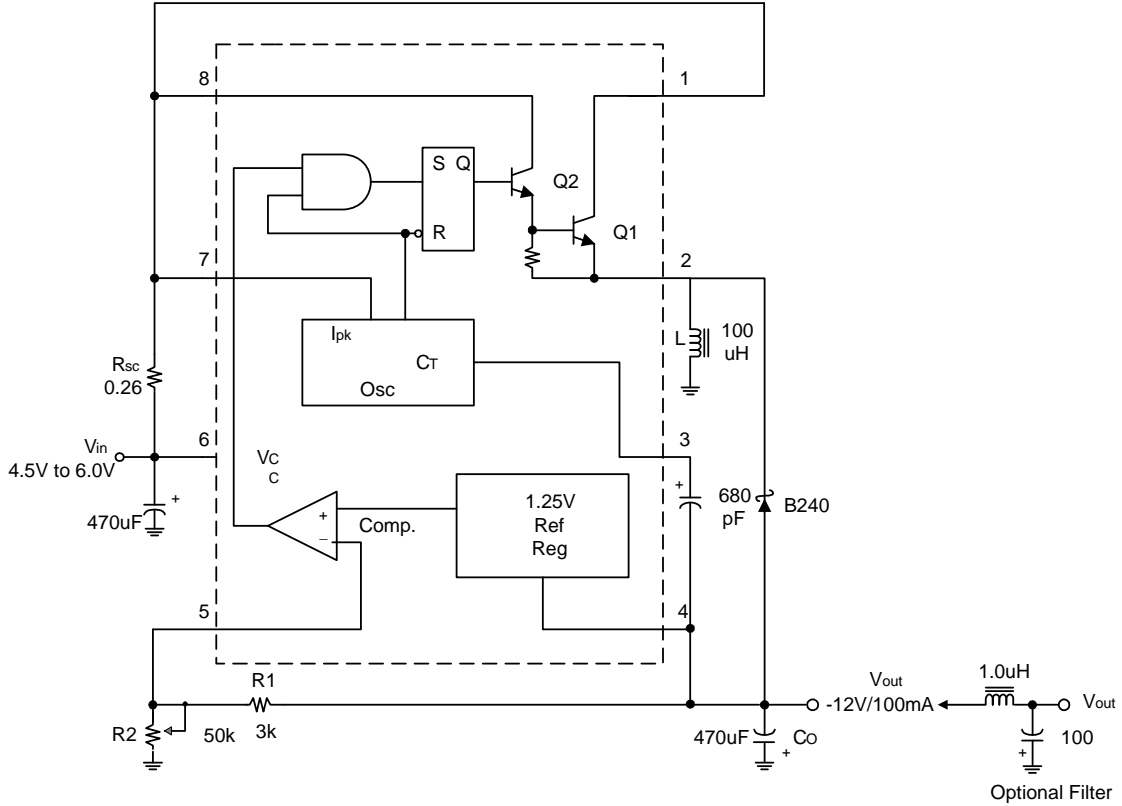

Test	Conditions	Results
Line Regulation	$V_{in} = 4.5V \text{ to } 6.0V, I_o = 100mA$	$20mV = \pm 0.08\%$
Load Regulation	$V_{in} = 5.0V, I_o = 20mA \text{ to } 100mA$	$30mV = \pm 0.12\%$
Output Ripple	$V_{in} = 5.0V, I_o = 100mA$	$500mV_{PP}$
Efficiency	$V_{in} = 5.0V, I_o = 100mA$	60%

### Ordering Information

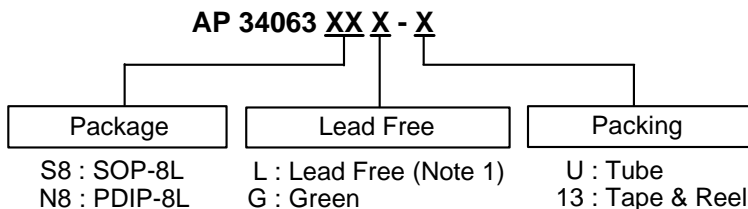

Device	Package Code	Packaging (Note 3)	Tube		13" Tape and Reel	
			Quantity	Part Number Suffix	Quantity	Part Number Suffix
AP34063S8L-13	S8	SOP-8L	NA	NA	2500/Tape & Reel	-13
AP34063S8G-13	S8	SOP-8L	NA	NA	2500/Tape & Reel	-13
AP34063N8L-U	N8	PDIP-8L	60	- U	NA	NA



Notes: 1. PDIP-8L is available in "Lead Free" product only.  
 2. EU Directive 2002/95/EC (RoHS). All applicable RoHS exemptions applied. Please visit our website at [http://www.diodes.com/products/lead\\_free.html](http://www.diodes.com/products/lead_free.html).  
 3. Pad layout as shown on Diodes Inc. suggested pad layout document AP02001, which can be found on our website at <http://www.diodes.com/datasheets/ap02001.pdf>.

### Pin Assignment

(1) SOP-8L

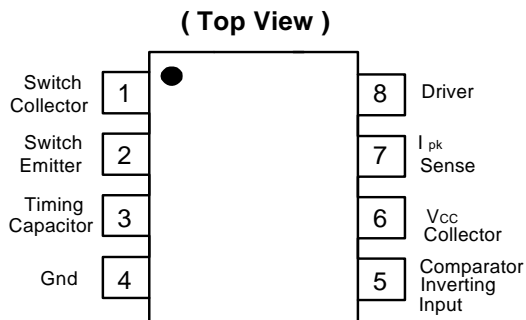

(2) PDIP-8L

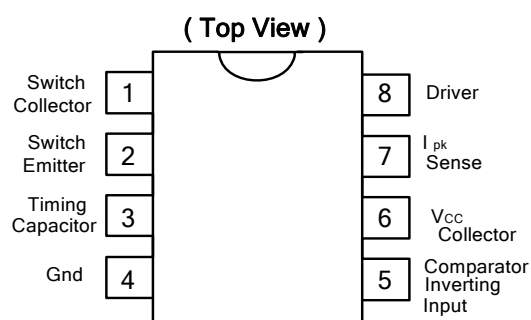

## Maximum Ratings

Symbol	Parameter	Value	Unit	
$V_{CC}$	Power Supply Voltage	40	V	
$V_{IR}$	Comparator Input Voltage Range	-0.3 ~ +40	V	
$V_C$ (switch)	Switch Collector Voltage	40	V	
$V_E$ (switch)	Switch Emitter Voltage ( $V_{Pin\ 1} = 40V$ )	40	V	
$V_{CE}$ (switch)	Switch Collector to Emitter Voltage	40	V	
$V_C$ (driver)	Driver Collector Voltage	40	V	
$I_C$ (driver)	Driver Collector Current	100	mA	
$I_{SW}$	Switch Current	1.6	A	
$P_D$	Power Dissipation and Thermal Characteristics	SOP: $T_A = 25^\circ C$	600	mW
		PDIP: $T_A = 25^\circ C$	1.25	W
		Thermal Resistance	160	$^\circ C/W$
$\theta_{JA}$				
$T_{MJ}$	Maximum Junction Temperature	+150	$^\circ C$	
$T_{OP}$	Operating Junction Temperature Range	0 ~ +105	$^\circ C$	
$T_{stg}$	Storage Temperature Range	-65 ~ +150	$^\circ C$	

Notes: 4. Maximum package power dissipation limits must be observed.  
5. Low duty cycle pulse techniques are used during test to maintain junction temperature as close to ambient temperature as possible.

## Electrical Characteristics ( $V_{CC} = 5.0V$ , unless otherwise specified)

Symbol	Characteristics	Min	Typ.	Max	Unit
<b>OSCILLATOR</b>					
$f_{osc}$	Frequency ( $V_{Pin\ 5} = 0V$ , $C_T = 1.0nF$ , $T_A = 25^\circ C$ )	24	33	42	kHz
$I_{chg}$	Charge Current ( $V_{CC} = 5.0V$ to $40V$ , $T_A = 25^\circ C$ )	24	30	42	$\mu A$
$I_{dischg}$	Discharge Current ( $V_{CC} = 5.0V$ to $40V$ , $T_A = 25^\circ C$ )	140	200	260	$\mu A$
$I_{dischg} / I_{chg}$	Discharge to Charge Current Ratio (Pin 7 to $V_{CC}$ , $T_A = 25^\circ C$ )	5.2	6.5	7.5	-
$V_{ipk}$ (sense)	Current Limit Sense Voltage ( $I_{chg} = I_{dischg}$ , $T_A = 25^\circ C$ )	300	400	450	mV
<b>OUTPUT SWITCH (Note 3)</b>					
$V_{CE}$ (sat)	Saturation Voltage, Darlington Connection ( $I_{SW} = 1.0A$ , Pins 1,8 connected)	-	1.0	1.3	V
$V_{CE}$ (sat)	Saturation Voltage, Darlington Connection ( $I_{SW} = 1.0A$ , $I_D = 50mA$ , Forced $\beta \approx 20$ )	-	0.45	0.7	V
$h_{FE}$	DC Current Gain ( $I_{SW} = 1.0A$ , $V_{CE} = 5.0V$ , $T_A = 25^\circ C$ )	50	75	-	-
$I_C$ (off)	Collector Off-State Current ( $V_{CE} = 40V$ )	-	0.01	100	$\mu A$
<b>COMPARATOR</b>					
$V_{th}$	Threshold Voltage	-	-	-	V
-	$T_A = 25^\circ C$	1.225	1.25	1.275	-
-	$T_A = 0^\circ C \sim 70^\circ C$	1.21	-	1.29	-
$Reg_{line}$	Threshold Voltage Line Regulation ( $V_{CC} = 3.0V$ to $40V$ )	-	1.4	6.0	mV
<b>TOTAL DEVICE</b>					
$I_{CC}$	Supply Current ( $V_{CC} = 5.0V$ to $40V$ , $C_T = 1.0nF$ , Pin 7 = $V_{CC}$ , $V_{Pin\ 5} > V_{th}$ Pin 2 = Gnd, remaining pins open)	-	-	3.5	mA

**Representative Schematic Diagram**

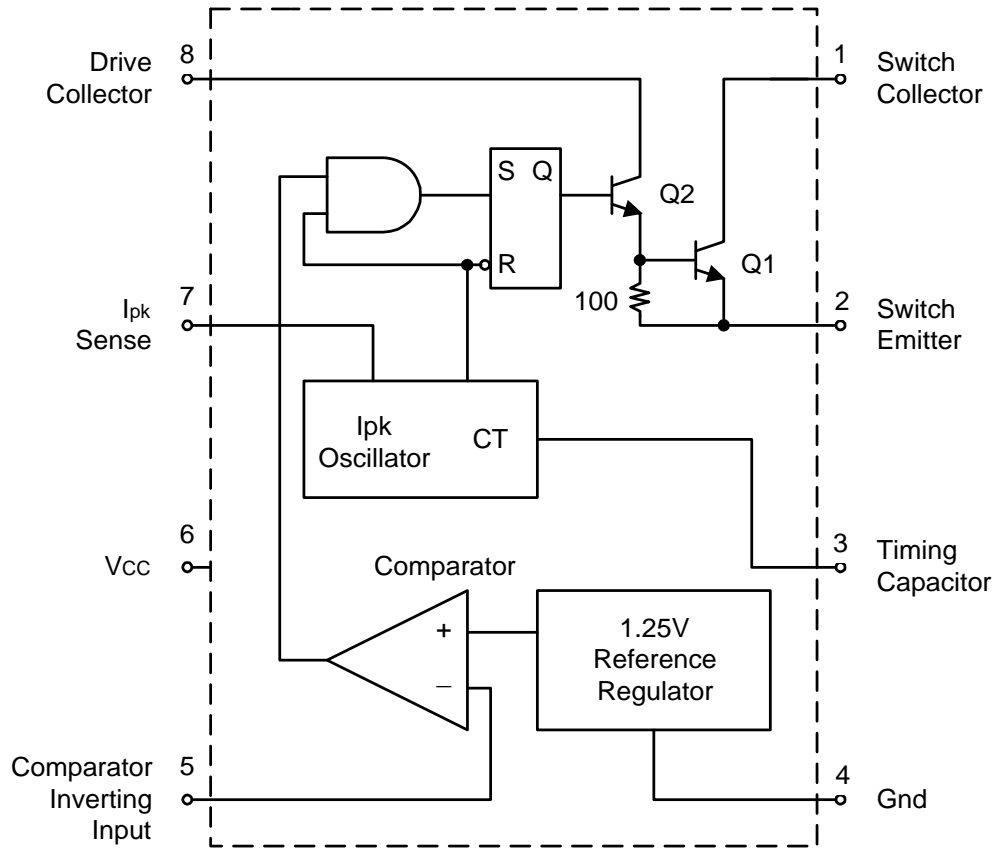

(Bottom View)

**Typical Performance Characteristics**

Figure 1. Vce(sat) versus Ie

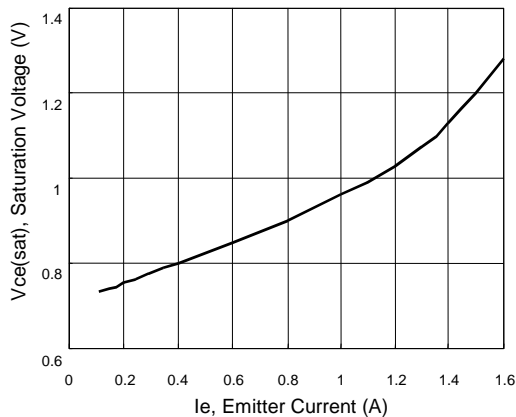

Figure 2. Reference Voltage versus Temp.

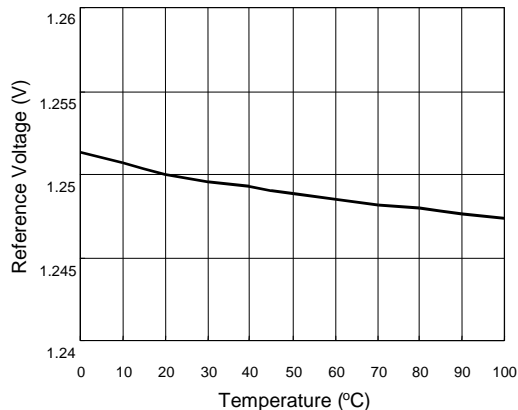

Figure 3. Current Limit Sense Voltage versus Temperature

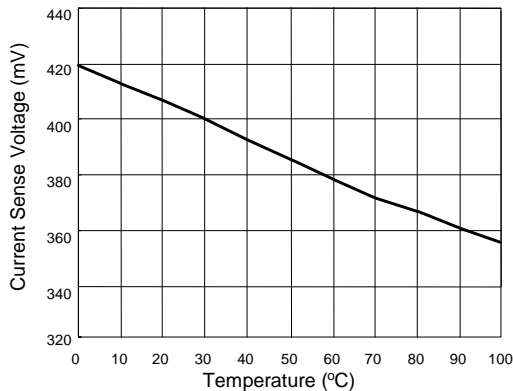

Figure 4. Standby Supply Current versus Supply Voltage

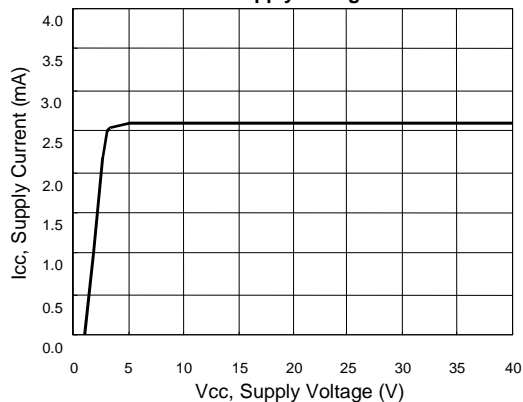

Figure 5. Emitter Follower Configuration Output Saturation Voltage vs. Emitter Current

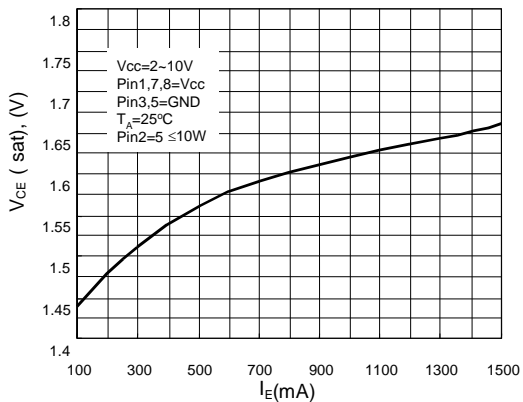
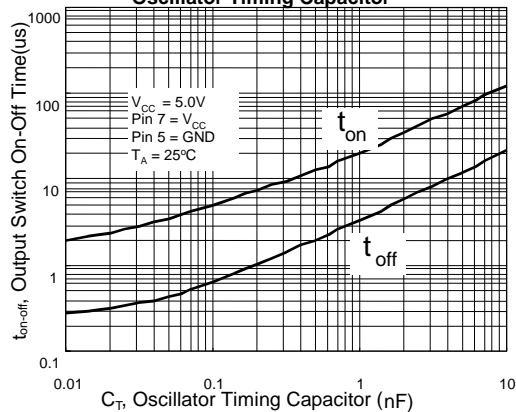

Figure 6. Output Switch On-Off Time versus Oscillator Timing Capacitor



**Design Formula Table**

Calculation	Step-Up			Step-Down			Voltage-Inverting		
$t_{on} / t_{off}$	$V_{out} + V_F - V_{in (min)}$			$V_{out} + V_F$			$ V_{out}  + V_F$		
	$V_{in (min)} - V_{sat}$			$V_{in(min)} - V_{sat} - V_{out}$			$V_{in} - V_{sat}$		
$(t_{on} + t_{off})$	$1/f$			$1/f$			$1/f$		
$t_{off}$	$t_{on} + t_{off}$			$t_{on} + t_{off}$			$t_{on} + t_{off}$		
	$t_{on}$	+1		$t_{on}$	+1		$t_{on}$	+1	
$t_{off}$	$t_{off}$			$t_{off}$					
$t_{on}$	$(t_{on} + t_{off}) - t_{off}$			$(t_{on} + t_{off}) - t_{off}$			$(t_{on} + t_{off}) - t_{off}$		
$C_T$	$4.0 \times 10^{-5} t_{on}$			$4.0 \times 10^{-5} t_{on}$			$4.0 \times 10^{-5} t_{on}$		
$I_{pk} (switch)$	$2I_{out (max)} (t_{on} / t_{off} + 1)$			$2I_{out (max)}$			$2I_{out (max)} (t_{on} / t_{off} + 1)$		
$R_{sc}$	$0.3 / I_{pk} (switch)$			$0.3 / I_{pk} (switch)$			$0.3 / I_{pk} (switch)$		
$L (min)$	$(V_{in (min)} - V_{sat})$	$t_{on (max)}$		$(V_{in (min)} - V_{sat} - V_{out})$	$t_{on (max)}$		$(V_{in (min)} - V_{sat})$	$t_{on (max)}$	
	$I_{pk} (switch)$			$I_{pk} (switch)$			$I_{pk} (switch)$		
$C_O$	9	$I_{out} t_{on}$		$I_{pk} (switch) (t_{off} + t_{on})$			$I_{out} t_{on}$		
		$V_{ripple (pp)}$		$8V_{ripple (pp)}$			$V_{ripple (pp)}$		

$V_{sat}$  = Saturation voltage of the output switch.

$V_F$  = Forward voltage drop of the output rectifier.

**The following power supply characteristics must be chosen:**

$V_{in}$  - Nominal input voltage.

$V_{out}$  - Desired output voltage,  $|V_{out}| = 1.25 (1+R2/R1)$

$I_{out}$  - Desired output current.

$f_{min}$  - Minimum desired output switching frequency at the selected values of  $V_{in}$  and  $I_o$ .

$V_{ripple(pp)}$  - Desired peak-to-peak output ripple voltage. In practice, the calculated capacitor value will need to be increased due to its equivalent series resistance and board layout. The ripple voltage should be kept to a low value since it will directly affect the line and load regulation.

**Marking Information**

(1) SOP-8L

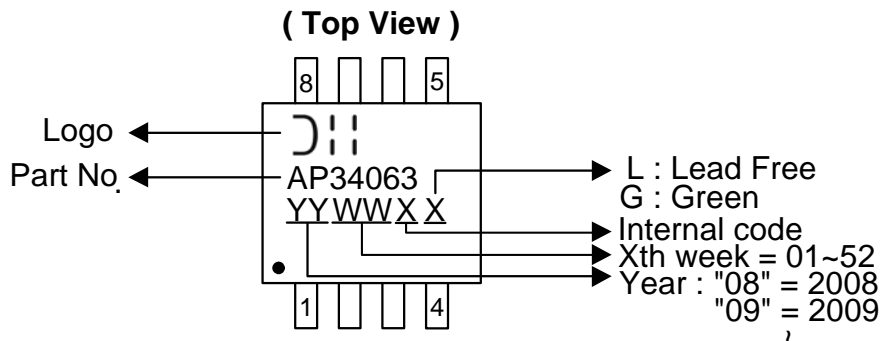

(2) PDIP-8L

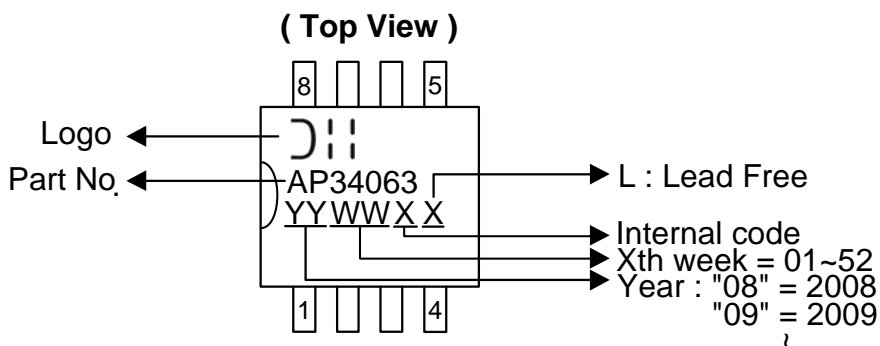

**Package Information (All Dimensions in mm)**

**(1) SOP-8L**

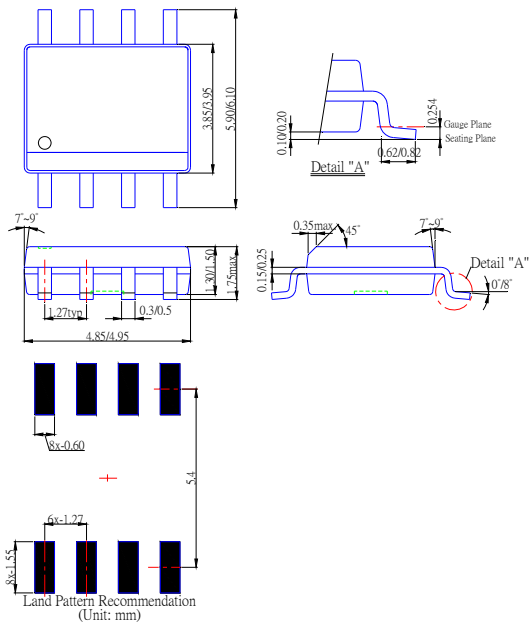

**(2) PDIP-8L**

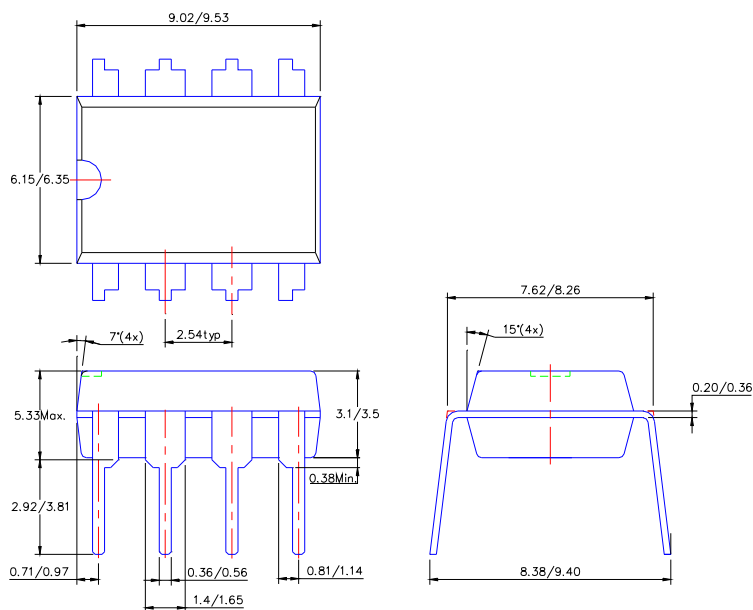

**IMPORTANT NOTICE**

DIODES INCORPORATED MAKES NO WARRANTY OF ANY KIND, EXPRESS OR IMPLIED, WITH REGARDS TO THIS DOCUMENT, INCLUDING, BUT NOT LIMITED TO, THE IMPLIED WARRANTIES OF MERCHANTABILITY AND FITNESS FOR A PARTICULAR PURPOSE (AND THEIR EQUIVALENTS UNDER THE LAWS OF ANY JURISDICTION).

Diodes Incorporated and its subsidiaries reserve the right to make modifications, enhancements, improvements, corrections or other changes without further notice to this document and any product described herein. Diodes Incorporated does not assume any liability arising out of the application or use of this document or any product described herein; neither does Diodes Incorporated convey any license under its patent or trademark rights, nor the rights of others. Any Customer or user of this document or products described herein in such applications shall assume all risks of such use and will agree to hold Diodes Incorporated and all the companies whose products are represented on Diodes Incorporated website, harmless against all damages.

Diodes Incorporated does not warrant or accept any liability whatsoever in respect of any products purchased through unauthorized sales channel.

Should Customers purchase or use Diodes Incorporated products for any unintended or unauthorized application, Customers shall indemnify and hold Diodes Incorporated and its representatives harmless against all claims, damages, expenses, and attorney fees arising out of, directly or indirectly, any claim of personal injury or death associated with such unintended or unauthorized application.

Products described herein may be covered by one or more United States, international or foreign patents pending. Product names and markings noted herein may also be covered by one or more United States, international or foreign trademarks.

**LIFE SUPPORT**

Diodes Incorporated products are specifically not authorized for use as critical components in life support devices or systems without the express written approval of the Chief Executive Officer of Diodes Incorporated. As used herein:

- A. Life support devices or systems are devices or systems which:
1. are intended to implant into the body, or
  2. support or sustain life and whose failure to perform when properly used in accordance with instructions for use provided in the labeling can be reasonably expected to result in significant injury to the user.
- B. A critical component is any component in a life support device or system whose failure to perform can be reasonably expected to cause the failure of the life support device or to affect its safety or effectiveness.

Customers represent that they have all necessary expertise in the safety and regulatory ramifications of their life support devices or systems, and acknowledge and agree that they are solely responsible for all legal, regulatory and safety-related requirements concerning their products and any use of Diodes Incorporated products in such safety-critical, life support devices or systems, notwithstanding any devices- or systems-related information or support that may be provided by Diodes Incorporated. Further, Customers must fully indemnify Diodes Incorporated and its representatives against any damages arising out of the use of Diodes Incorporated products in such safety-critical, life support devices or systems.

Copyright © 2009, Diodes Incorporated

[www.diodes.com](http://www.diodes.com)

## Looking for pricing, stock, or lifecycle information?

Click below to explore more details on WIN SOURCE:

- ⊖ [View AP34063N8L-U on WIN SOURCE](#)
- ⊖ [Diodes Incorporated Information](#)

## Optimize Your Supply Chain with WIN SOURCE Solutions

- ✓ Global Sourcing Solution
- ✓ Obsolete Management
- ✓ Cost Control Management
- ✓ Shortage Management
- ✓ Alternative Solution
- ✓ Excess Inventory Management