



# THE DATASHEET OF LF412CDRG4



# LF412C DUAL JFET-INPUT OPERATIONAL AMPLIFIER

SLOS010B – MARCH 1987 – REVISED AUGUST 1994

- Low Input Bias Current . . . 50 pA Typ
- Low Input Noise Current  
0.01 pA/√Hz Typ
- Low Supply Current . . . 4.5 mA Typ
- High Input impedance . . . 10<sup>12</sup> Ω Typ
- Internally Trimmed Offset Voltage
- Wide Gain Bandwidth . . . 3 MHz Typ
- High Slew Rate . . . 13 V/μs Typ

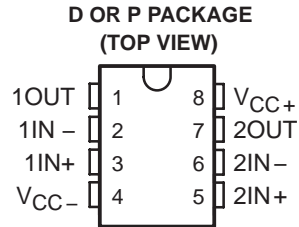

## description

This device is a low-cost, high-speed, JFET-input operational amplifier with very low input offset voltage and a specified maximum input offset voltage drift. It requires low supply current yet maintains a large gain bandwidth product and a fast slew rate. In addition, the matched high-voltage JFET input provides very low input bias and offset currents.

The LF412C can be used in applications such as high-speed integrators, digital-to-analog converters, sample-and-hold circuits, and many other circuits.

The LF412C is characterized for operation from 0°C to 70°C.

## symbol (each amplifier)

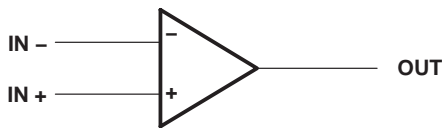

### AVAILABLE OPTIONS

T <sub>A</sub>	V <sub>IO</sub> max AT 25°C	PACKAGE	
		SMALL OUTLINE (D)	PLASTIC DIP (P)
0°C to 70°C	3 mV	LF412CD	LF412CP

The D packages are available taped and reeled. Add the suffix R to the device type (ie., LF412CDR).

## absolute maximum ratings over operating free-air temperature range (unless otherwise noted)

Supply voltage, V <sub>CC+</sub>	18 V
Supply voltage, V <sub>CC-</sub>	-18 V
Differential input voltage, V <sub>ID</sub>	±30 V
Input voltage, V <sub>I</sub> (see Note 1)	±15 V
Duration of output short circuit	unlimited
Continuous total power dissipation	500 mW
Operating temperature range	0°C to 70°C
Storage temperature range	-65°C to 150°C
Lead temperature 1,6 mm (1/16 inch) from case for 10 seconds	260°C

NOTE 1: Unless otherwise specified, the absolute maximum negative input voltage is equal to the negative power supply voltage.

PRODUCTION DATA information is current as of publication date. Products conform to specifications per the terms of Texas Instruments standard warranty. Production processing does not necessarily include testing of all parameters.



POST OFFICE BOX 655303 • DALLAS, TEXAS 75265  
POST OFFICE BOX 1443 • HOUSTON, TEXAS 77251-1443

Copyright © 1994, Texas Instruments Incorporated

# LF412C

## DUAL JFET-INPUT OPERATIONAL AMPLIFIER

SLOS010B – MARCH 1987 – REVISED AUGUST 1994

### recommended operating conditions

	MIN	MAX	UNIT
Supply voltage, $V_{CC+}$	3.5	18	V
Supply voltage, $V_{CC-}$	-3.5	-18	V

### electrical characteristics over operating free-air temperature range, $V_{CC\pm} = \pm 15$ V (unless otherwise specified)

PARAMETER	TEST CONDITIONS	$T_A$ †	MIN	TYP	MAX	UNIT
$V_{IO}$ Input offset voltage	$V_{IC} = 0, R_S = 10\text{ k}\Omega$	25°C		1	3	mV
$\alpha_{VIO}$ Average temperature coefficient of input offset voltage	$V_{IC} = 0, R_S = 10\text{ k}\Omega$			10	20‡	$\mu\text{V}/^\circ\text{C}$
$I_{IO}$ Input offset current§	$V_{IC} = 0$	25°C		25	100	pA
		70°C			4	nA
$I_{IB}$ Input bias current§	$V_{IC} = 0$	25°C		50	200	pA
		70°C			8	nA
$V_{ICR}$ Common-mode input voltage range			$\pm 11$	-11.5 to 14.5		V
$V_{OM}$ Maximum peak output voltage swing	$R_L = 10\text{ k}\Omega$		$\pm 12$	$\pm 13.5$		V
$A_{VD}$ Large-signal differential voltage	$V_O = \pm 10\text{ V}, R_L = 2\text{ k}\Omega$	25°C	25	200		V/mV
		Full range	15	200		
$r_i$ Input resistance	$T_A = 25^\circ\text{C}$			$10^{12}$		$\Omega$
CMRR Common-mode rejection ratio	$R_S \leq 10\text{ k}\Omega$		70	100		dB
$k_{SVR}$ Supply-voltage rejection ratio	See Note 2		70	100		dB
$I_{CC}$ Supply current				4.5	6.8	mA

† Full range is 0°C to 70°C.

‡ At least 90% of the devices meet this limit for  $\alpha_{VIO}$ .

§ Input bias currents of a FET-input operational amplifier are normal junction reverse currents, which are temperature sensitive. Pulse techniques must be used that will maintain the junction temperatures as close to the ambient temperature as possible.

NOTE 2: Supply-voltage rejection ratio is measured for both supply magnitudes increasing or decreasing simultaneously.

### operating characteristics, $V_{CC\pm} = \pm 15$ V, $T_A = 25^\circ\text{C}$

PARAMETER	TEST CONDITIONS	MIN	TYP	MAX	UNIT
$V_{O1}/V_{O2}$ Crosstalk attenuation	$f = 1\text{ kHz}$		120		dB
SR Slew rate		8	13		V/ $\mu\text{s}$
$B_1$ Unity-gain bandwidth		2.7	3		MHz
$V_n$ Equivalent input noise voltage	$f = 1\text{ kHz}, R_S = 20\text{ }\Omega$		18		$\text{nV}/\sqrt{\text{Hz}}$
$I_n$ Equivalent input noise current	$f = 1\text{ kHz}$		0.01		$\text{pA}/\sqrt{\text{Hz}}$



**PACKAGING INFORMATION**

Orderable Device	Status (1)	Package Type	Package Drawing	Pins	Package Qty	Eco Plan (2)	Lead finish/ Ball material (6)	MSL Peak Temp (3)	Op Temp (°C)	Device Marking (4/5)	Samples
LF412 MWC	ACTIVE	WAFERSALE	YS	0	1	RoHS & Green	Call TI	Level-1-NA-UNLIM	-40 to 85		Samples
LF412CDR	ACTIVE	SOIC	D	8	2500	RoHS & Green	NIPDAU	Level-1-260C-UNLIM	0 to 70	LF412C	Samples
LF412CDRE4	ACTIVE	SOIC	D	8	2500	TBD	Call TI	Call TI	0 to 70		Samples
LF412CDRG4	ACTIVE	SOIC	D	8	2500	TBD	Call TI	Call TI	0 to 70		Samples
LF412CP	ACTIVE	PDIP	P	8	50	RoHS & Green	NIPDAU	N / A for Pkg Type	0 to 70	LF412CP	Samples

(1) The marketing status values are defined as follows:

**ACTIVE:** Product device recommended for new designs.

**LIFEBUY:** TI has announced that the device will be discontinued, and a lifetime-buy period is in effect.

**NRND:** Not recommended for new designs. Device is in production to support existing customers, but TI does not recommend using this part in a new design.

**PREVIEW:** Device has been announced but is not in production. Samples may or may not be available.

**OBSELETE:** TI has discontinued the production of the device.

(2) **RoHS:** TI defines "RoHS" to mean semiconductor products that are compliant with the current EU RoHS requirements for all 10 RoHS substances, including the requirement that RoHS substance do not exceed 0.1% by weight in homogeneous materials. Where designed to be soldered at high temperatures, "RoHS" products are suitable for use in specified lead-free processes. TI may reference these types of products as "Pb-Free".

**RoHS Exempt:** TI defines "RoHS Exempt" to mean products that contain lead but are compliant with EU RoHS pursuant to a specific EU RoHS exemption.

**Green:** TI defines "Green" to mean the content of Chlorine (Cl) and Bromine (Br) based flame retardants meet JS709B low halogen requirements of <=1000ppm threshold. Antimony trioxide based flame retardants must also meet the <=1000ppm threshold requirement.

(3) MSL, Peak Temp. - The Moisture Sensitivity Level rating according to the JEDEC industry standard classifications, and peak solder temperature.

(4) There may be additional marking, which relates to the logo, the lot trace code information, or the environmental category on the device.

(5) Multiple Device Markings will be inside parentheses. Only one Device Marking contained in parentheses and separated by a "~" will appear on a device. If a line is indented then it is a continuation of the previous line and the two combined represent the entire Device Marking for that device.

(6) Lead finish/Ball material - Orderable Devices may have multiple material finish options. Finish options are separated by a vertical ruled line. Lead finish/Ball material values may wrap to two lines if the finish value exceeds the maximum column width.

**Important Information and Disclaimer:** The information provided on this page represents TI's knowledge and belief as of the date that it is provided. TI bases its knowledge and belief on information provided by third parties, and makes no representation or warranty as to the accuracy of such information. Efforts are underway to better integrate information from third parties. TI has taken and continues to take reasonable steps to provide representative and accurate information but may not have conducted destructive testing or chemical analysis on incoming materials and chemicals. TI and TI suppliers consider certain information to be proprietary, and thus CAS numbers and other limited information may not be available for release.

In no event shall TI's liability arising out of such information exceed the total purchase price of the TI part(s) at issue in this document sold by TI to Customer on an annual basis.

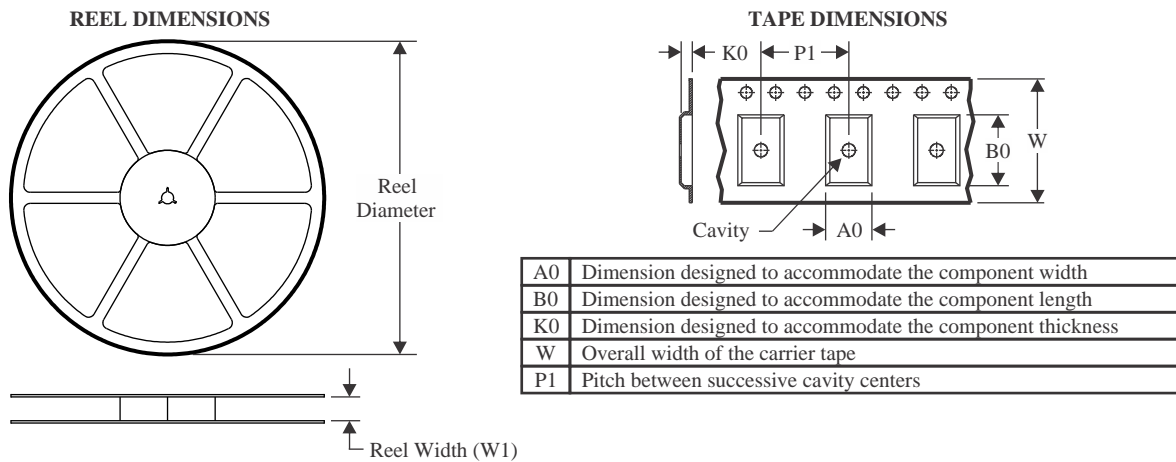
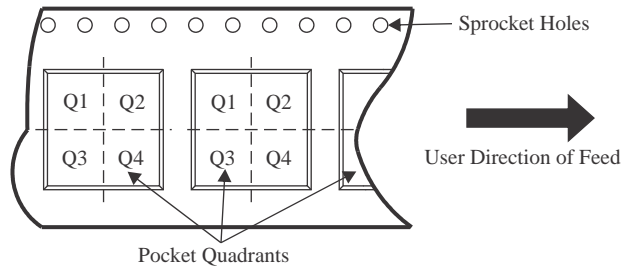
**TAPE AND REEL INFORMATION**

**QUADRANT ASSIGNMENTS FOR PIN 1 ORIENTATION IN TAPE**

\*All dimensions are nominal

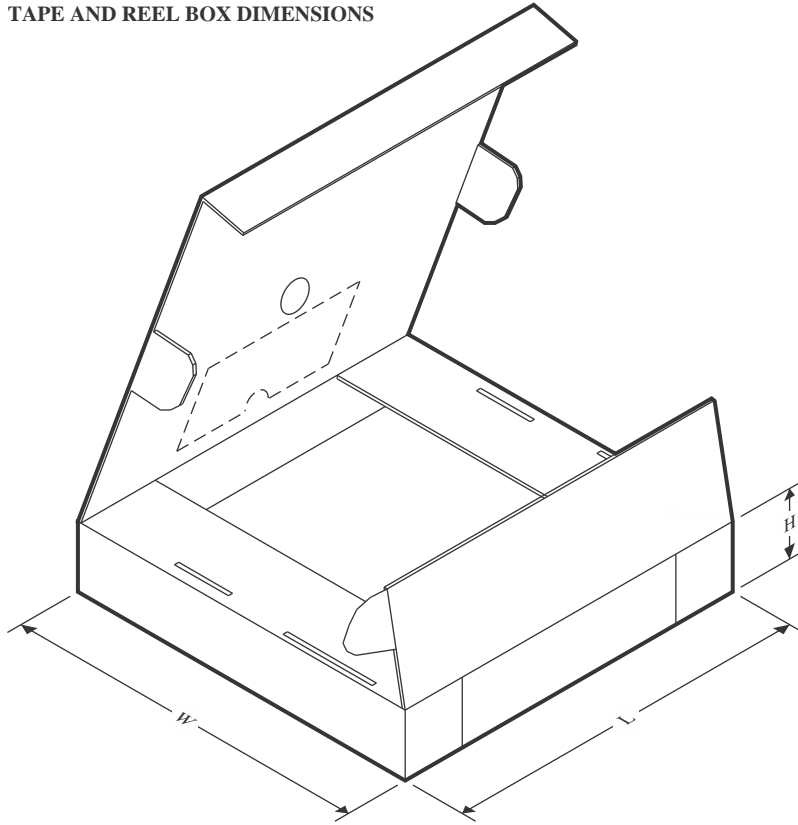
Device	Package Type	Package Drawing	Pins	SPQ	Reel Diameter (mm)	Reel Width W1 (mm)	A0 (mm)	B0 (mm)	K0 (mm)	P1 (mm)	W (mm)	Pin1 Quadrant
LF412CDR	SOIC	D	8	2500	330.0	12.4	6.4	5.2	2.1	8.0	12.0	Q1
LF412CDR	SOIC	D	8	2500	330.0	12.4	6.4	5.2	2.1	8.0	12.0	Q1

**TAPE AND REEL BOX DIMENSIONS**

\*All dimensions are nominal

Device	Package Type	Package Drawing	Pins	SPQ	Length (mm)	Width (mm)	Height (mm)
LF412CDR	SOIC	D	8	2500	356.0	356.0	35.0
LF412CDR	SOIC	D	8	2500	340.5	338.1	20.6

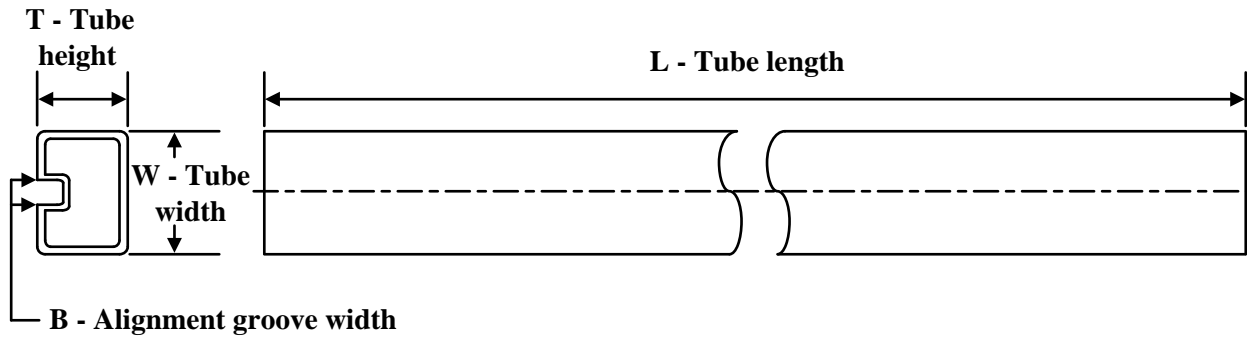
**TUBE**

\*All dimensions are nominal

Device	Package Name	Package Type	Pins	SPQ	L (mm)	W (mm)	T (μm)	B (mm)
LF412CP	P	PDIP	8	50	506	13.97	11230	4.32

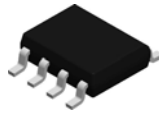

D0008A

# PACKAGE OUTLINE

SOIC - 1.75 mm max height

SMALL OUTLINE INTEGRATED CIRCUIT

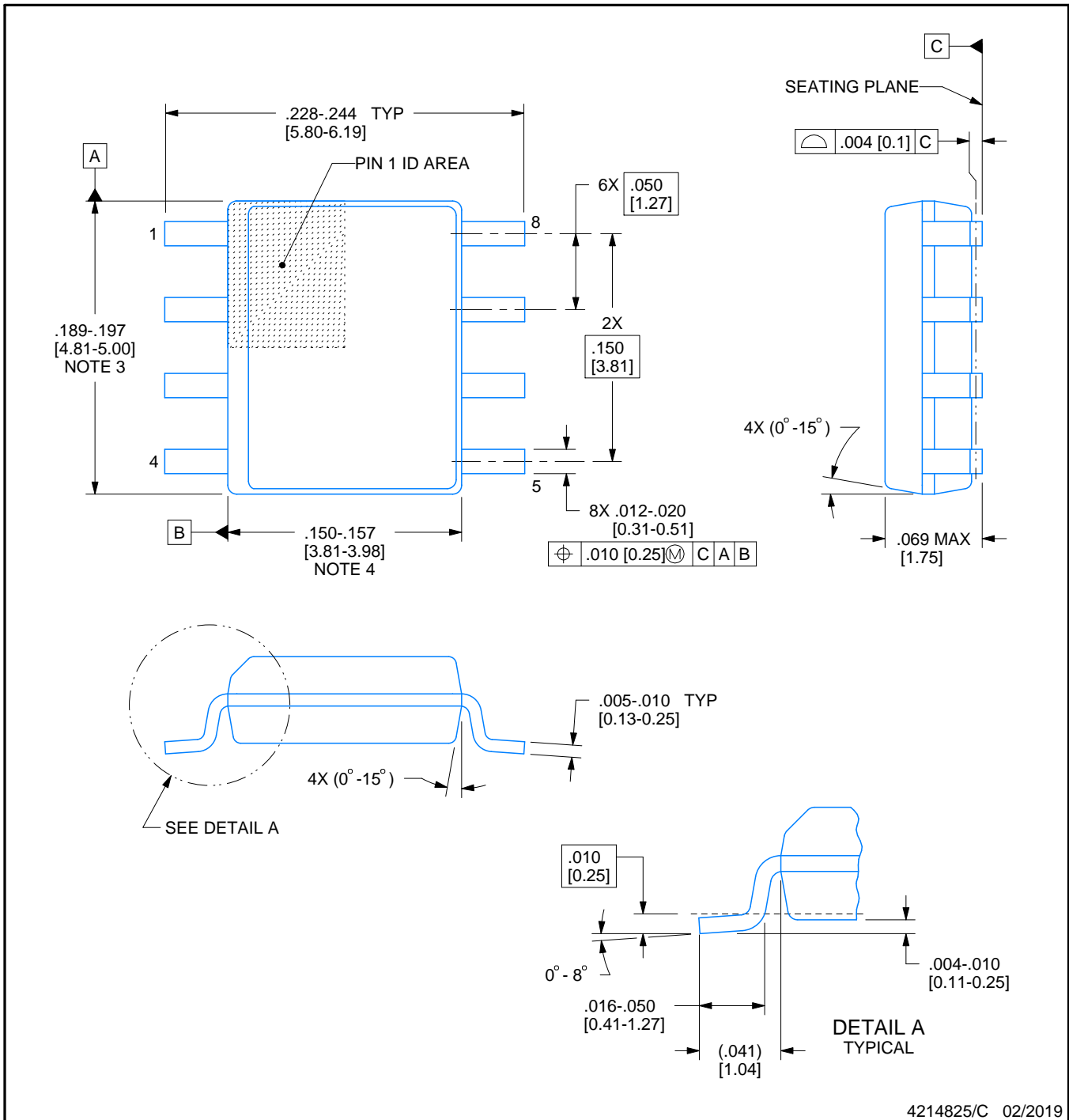

4214825/C 02/2019

## NOTES:

- Linear dimensions are in inches [millimeters]. Dimensions in parenthesis are for reference only. Controlling dimensions are in inches. Dimensioning and tolerancing per ASME Y14.5M.
- This drawing is subject to change without notice.
- This dimension does not include mold flash, protrusions, or gate burrs. Mold flash, protrusions, or gate burrs shall not exceed  $.006$  [0.15] per side.
- This dimension does not include interlead flash.
- Reference JEDEC registration MS-012, variation AA.

# EXAMPLE BOARD LAYOUT

D0008A

SOIC - 1.75 mm max height

SMALL OUTLINE INTEGRATED CIRCUIT

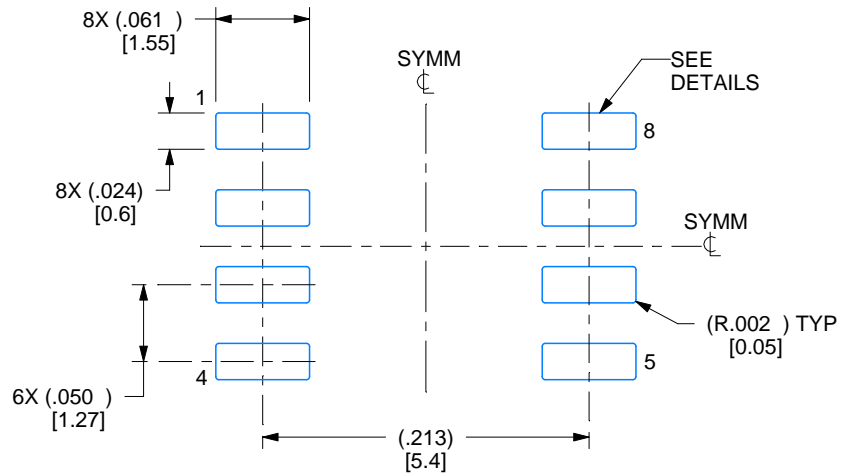

LAND PATTERN EXAMPLE  
EXPOSED METAL SHOWN  
SCALE:8X

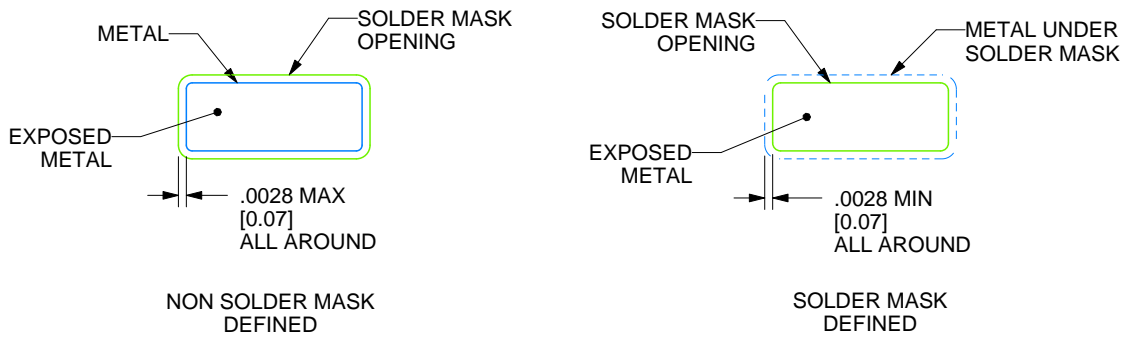

SOLDER MASK DETAILS

4214825/C 02/2019

NOTES: (continued)

6. Publication IPC-7351 may have alternate designs.

7. Solder mask tolerances between and around signal pads can vary based on board fabrication site.

# EXAMPLE STENCIL DESIGN

D0008A

SOIC - 1.75 mm max height

SMALL OUTLINE INTEGRATED CIRCUIT

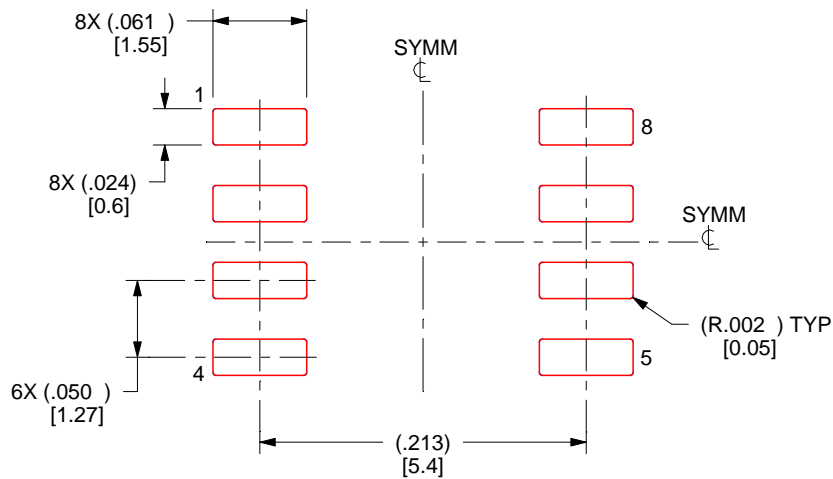

SOLDER PASTE EXAMPLE  
BASED ON .005 INCH [0.125 MM] THICK STENCIL  
SCALE:8X

4214825/C 02/2019

NOTES: (continued)

8. Laser cutting apertures with trapezoidal walls and rounded corners may offer better paste release. IPC-7525 may have alternate design recommendations.
9. Board assembly site may have different recommendations for stencil design.

P (R-PDIP-T8)

PLASTIC DUAL-IN-LINE PACKAGE



- NOTES:
- A. All linear dimensions are in inches (millimeters).
  - B. This drawing is subject to change without notice.
  - C. Falls within JEDEC MS-001 variation BA.

## IMPORTANT NOTICE AND DISCLAIMER

TI PROVIDES TECHNICAL AND RELIABILITY DATA (INCLUDING DATA SHEETS), DESIGN RESOURCES (INCLUDING REFERENCE DESIGNS), APPLICATION OR OTHER DESIGN ADVICE, WEB TOOLS, SAFETY INFORMATION, AND OTHER RESOURCES "AS IS" AND WITH ALL FAULTS, AND DISCLAIMS ALL WARRANTIES, EXPRESS AND IMPLIED, INCLUDING WITHOUT LIMITATION ANY IMPLIED WARRANTIES OF MERCHANTABILITY, FITNESS FOR A PARTICULAR PURPOSE OR NON-INFRINGEMENT OF THIRD PARTY INTELLECTUAL PROPERTY RIGHTS.

These resources are intended for skilled developers designing with TI products. You are solely responsible for (1) selecting the appropriate TI products for your application, (2) designing, validating and testing your application, and (3) ensuring your application meets applicable standards, and any other safety, security, regulatory or other requirements.

These resources are subject to change without notice. TI grants you permission to use these resources only for development of an application that uses the TI products described in the resource. Other reproduction and display of these resources is prohibited. No license is granted to any other TI intellectual property right or to any third party intellectual property right. TI disclaims responsibility for, and you will fully indemnify TI and its representatives against, any claims, damages, costs, losses, and liabilities arising out of your use of these resources.

TI's products are provided subject to [TI's Terms of Sale](#) or other applicable terms available either on [ti.com](https://www.ti.com) or provided in conjunction with such TI products. TI's provision of these resources does not expand or otherwise alter TI's applicable warranties or warranty disclaimers for TI products.

TI objects to and rejects any additional or different terms you may have proposed.

Mailing Address: Texas Instruments, Post Office Box 655303, Dallas, Texas 75265  
Copyright © 2024, Texas Instruments Incorporated

## Looking for pricing, stock, or lifecycle information?

Click below to explore more details on WIN SOURCE:

 [View LF412CDRG4](#) on WIN SOURCE

 [Texas Instruments](#) Information

## Optimize Your Supply Chain with WIN SOURCE Solutions

-  Global Sourcing Solution
-  Obsolete Management
-  Cost Control Management
-  Shortage Management
-  Alternative Solution
-  Excess Inventory Management