



THE DATASHEET OF PS383ESE



Features

- Low On-Resistance (16Ω typ) Minimizes Distortion and Error Voltages
- Low Glitching Reduces Step Errors in Sample-and-Holds. Charge Injection, 3pC typ
- Single Supply (+3V to +15V) or Split-Supply (±3V to ±8V) Operation
- Improved Second Sources for MAX381/MAX383/MAX385
- On-Resistance Matching Between Channels, 0.2 Ω typ
- On-Resistance Flatness, 1Ω typ
- Low Off-Channel Leakage, <2.5nA @ +85°C
- TTL/CMOS Logic Compatible
- Rail-to-Rail Analog Signal Dynamic Range
- Low Power Consumption <1μA

Applications

- Instrumentation, ATE
- Sample-and-Holds
- Audio Switching and Routing
- Telecommunication Systems
- PBX, PABX
- Battery-Powered Systems

Description

The PS381/PS383/PS385 are improved high precision, medium voltage analog switches designed to operate with +3V to ±8V power supplies.

The PS381 has two normally open (NO) switches. The PS383 is a dual, single-pole double-throw (SPDT) switch. The PS385 is a dual, double-pole single-throw (DPST) function. Each switch conducts current equally well in either direction when on. In the off state each switch blocks voltages up to the power-supply rails.

With ±5V power supplies, the PS381/PS383/PS385 guarantee <30Ω on-resistance. On-resistance matching between channels is within 2Ω. On-resistance flatness is less than 4Ω over the specified range. All three devices feature low leakage currents (<2 pA @ 25°C, <2.5nA @ +85°C) and fast switching speeds (t_{ON} < 130ns). Break-before-make switching action protects against momentary crosstalk (PS383).

These switches are fully specified for single +5V operation, with <45Ω R_{ON}, <2Ω R_{ON} match, and <4Ω R_{ON} flatness.

For operation below 5V the PI5A381A/PI5A383A/PI5A385A are also recommended.

Functional Diagrams, Pin Configurations, and Truth Tables

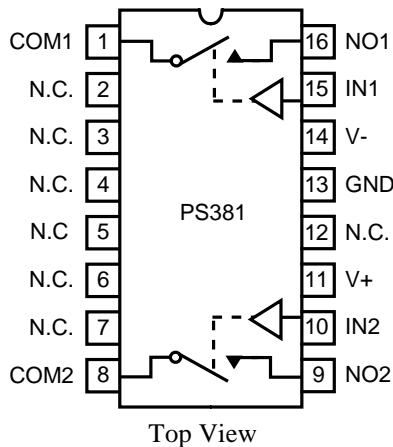

N.C = No Connect.

PS381	
Logic	Switch
0	OFF
1	ON

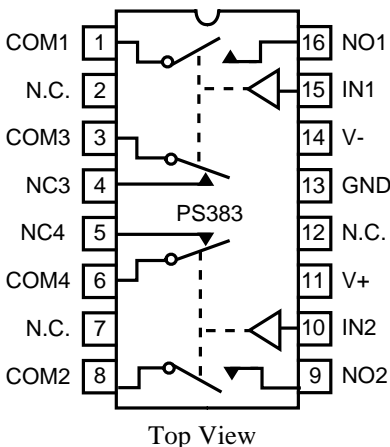

Switches shown for logic "0" input

PS383		
Logic	SW3, SW4	SW1, SW2
0	ON	OFF
1	OFF	ON

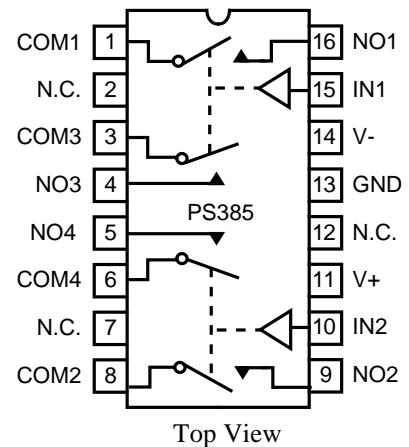

PS385	
Logic	Switch
0	OFF
1	ON

Absolute Maximum Ratings

Voltages Referenced to V-

V+	-0.3V to +17V
GND	-0.3V to +17V
GND	-0.3V to (V+) +0.3V
V _{IN} , V _{COM} , V _{NC} , V _{NO} (Note 1)	(V-) -2V to (V+) +2V or 30mA, whichever occurs first
Current (any terminal)	30mA
Peak Current, COM, NO, NC (pulsed at 1ms, 10% duty cycle)	100mA
ESD per Method 3015.7	>2000V

Thermal Information

Continuous Power Dissipation (T _A = +70°C)	
Plastic DIP (derate 10.5mW/°C above +70°C)	800mW
Narrow SO (derate 8.7mW/°C above +70°C)	650mW
Storage Temperature	-65°C to +150°C
Lead Temperature (soldering, 10s)	+300°C

Note 1: Signals on NC, NO, COM, or IN exceeding V+ or V- are clamped by internal diodes. Limit forward diode current to maximum current rating

Caution: Stresses beyond those listed under "Absolute Maximum Ratings" may cause permanent damage to the device. This is a stress only rating and operation of the device at these or any other conditions beyond those indicated in the operational sections of this specification is not implied.

Electrical Specifications - Dual Supplies

(V_± = ± 5V ±10%, GND = 0V, V_{INH} = 2.4V, V_{INL} = 0.8V)

Parameter	Symbol	Conditions	Temp. (°C)	Min ⁽²⁾	Typ ⁽¹⁾	Max ⁽²⁾	Units
Analog Switch							
Analog Signal Range ⁽³⁾	V _{ANALOG}		Full	V-		V+	V
On Resistance	R _{ON}	V+ = 4.5V, V- = -4.5V, V _{NO} or V _{NC} = ±3.5V I _{COM} = -10mA,	25		16	30	Ω
			Full			40	
On-Resistance Match Between Channel ⁽⁴⁾	ΔR _{ON}	V _{NO} or V _{NC} = ±3V, I _{COM} = -10mA, V+ = 5V, V- = -5V	25		0.2	2	Ω
			Full			4	
On-Resistance Flatness ⁽⁵⁾	R _{FLAT(ON)}	V+ = 5V, V- = -5V, I _{COM} = -10mA, V _{NO} or V _{NC} = ±3.5V	25		1	4	Ω
			Full			6	
NO or NC Off Leakage Current ⁽⁶⁾	I _{NO(OFF)} or I _{NC(OFF)}	V+ = 5.5V, V- = -5.5V, V _{COM} = ± 4.5V, V _{NC} or V _{NO} = +4.5V	25	-0.1	-0.001	0.1	nA
			Full	-2.5		2.5	
COM Off Leakage Current ⁽⁶⁾	I _{COM(OFF)}	V+ = 5.5V, V- = -5.5V V _{COM} = ± 4.5V, V _{NO} or V _{NC} = +4.5V	25	-0.1	-0.001	0.1	nA
			Full	-2.5		2.5	
COM On Leakage Current ⁽⁷⁾	I _{COM(ON)}	V+ = 5.5V, V- = -5.5V, V _{COM} = ±4.5V V _{NO} or V _{NC} = ±4.5V	25	-0.2	0.002	0.2	nA
			Full	-5		5	

Electrical Specifications - Dual Supplies (continued)

 $(V \pm \pm 5V \pm 10\%, GND = 0V, V_{INH} = 2.4V, V_{INL} = 0.8V)$

Parameter	Symbol	Conditions	Temp (°C)	Min ⁽¹⁾	Typ ⁽²⁾	Max ⁽¹⁾	Units	
Logic Input								
Input Current with Input Voltage High	I_{INH}	$V_{IN} = 2.4V$, all others = 0.8V	Full	-0.5	0.005	0.5	μA	
Input Current with Input Voltage Low	I_{INL}	$V_{IN} = 0.8V$, all others = 2.4V		-0.5	0.005	0.5		
Logic High Input Voltage	V_{AH}			2.4			V	
Logic Low Input Voltage	V_{AL}					0.8		
Dynamic								
Turn-On Time	t_{ON}	$V_{COM} = \pm 3V$, Figure 2	25		51	130	ns	
			Full					175
Turn-Off Time	t_{OFF}		25		29	75		
			Full					100
Break-Before-Make TimeDelay	t_D	PS383 only, Figure 3	25	10	20			
Charge Injection	Q	$C_L = 1nF, V_{GEN} = 0V, R_{GEN} = 0\Omega$, Figure 4	25		2	5	pC	
Off Isolation ⁽⁷⁾	OIRR	$R_L = 50\Omega, C_L = 5pF, f = 1MHz$, Figure 5			-65			dB
Crosstalk ⁽⁸⁾	X_{TALK}	$R_L = 50\Omega, C_L = 5pF, f = 1MHz$, Figure 6			-90			
NC or NO Off Capacitance	$C_{(OFF)}$	$f = 1MHz$, Figure 7				12		pF
COM Off Capacitance	$C_{COM(OFF)}$	$f = 1MHz$, Figure 7				12		
COM On Capacitance	$C_{COM(ON)}$	$f = 1MHz$, Figure 8				25		
Supply								
Power-Supply Range	V+, V-			± 3		± 8	V	
Positive Supply Current	I+	$V+ = 5.5V, V- = -5.5V, V_{IN} = 0V$ or V+, all channels on or off	Full	-1		1	μA	
Negative Supply Current	I-			-1		1		

Notes:

- The algebraic convention, where the most negative value is a minimum and the most positive is a maximum, is used in this data sheet.
- Typical values are for DESIGN AID ONLY, not guaranteed or subject to production testing.
- Guaranteed by design
- $\Delta R_{ON} = \Delta R_{ON \max} - \Delta R_{ON \min}$
- Flatness is defined as the difference between the maximum and minimum value of on-resistance measured.
- Leakage parameters are 100% tested at maximum rated hot temperature and guaranteed by correlation at +25°C.
- Off Isolation = $20 \log_{10} [V_{COM} / (V_{NO} \text{ or } V_{NO})]$. See figure 5.
- Between any two switches. See figure 6.

Electrical Specifications - Single +5V Supply

(V+ = +5V ±10%, V- = 0V, GND = 0V, V_{INH} = 2.4V, V_{INL} = 0.8V)

Parameter	Symbol	Conditions	Temp°C	Min. ⁽²⁾	Typ. ⁽²⁾	Max. ⁽²⁾	Units
Analog Switch							
Analog Switch Range ⁽³⁾	V _{ANALOG}		Full	0		V+	V
On-Resistance	R _{ON}	V+ = 5.0V, V- = 0V I _{COM} = -10mA, V _{NO} or V _{NC} = 3.5V	25		25	45	Ω
			Full			60	
On-Resistance Match Between Channels ⁽⁴⁾	ΔR _{ON}	V+ = 5V, V _{COM} = -10mA, V _{NO} or V _{NC} = 3V	25		0.5	2	
			Full			4	
On-Resistance Flatness ⁽⁵⁾		V+ = 5V, V- = 0V, I _{COM} = -10mA, V _{NO} or V _{NC} = 1V, 4V	25		1	4	
			Full			6	
NO or NC Off Leakage Current ⁽⁹⁾	I _{NO(OFF)} or I _{NC(OFF)}	V+ = 5.5V, V _{COM} = 0V, V _{NO} or V _{NC} = 4.5V	25	-0.1	0.001	0.1	nA
			Full	-2.5		2.5	
COM Off Leakage Current ⁽⁹⁾	I _{COM(OFF)}	V+ = 5.5V, V _{COM} = 4.5V, V _{NO} or V _{NC} = 0V	25	-01	0.001	0.1	
			Full	-2.5		2.5	
COM On Leakage Current ⁽⁹⁾	I _{COM(ON)}	V _{COM} = 4.5V, V _{NO} or V _{NC} = 4.5V, V+ = 5.5V	25	-0.2	-0.002	0.2	
			Full	-5		5	
Dynamic							
Turn-On-Time ⁽³⁾	t _{ON}	V _{COM} = 3V, Figure 2	25		63	170	ns
			Full			240	
Turn-Off-Time ⁽³⁾	t _{OFF}		25		34	50	
			Full			100	
Break-Before-Make Time Delay ⁽³⁾	t _D	PS383 only	25	10	20		
Charge Injection ⁽³⁾	Q	C _L = 1nF, V _{GEN} = 0V, R _{GEN} = 0Ω, Figure 4	25		0	5	pC
Supply							
Positive Supply Current	I+	All channels on or off, V _{IN} = 0V or V+, V+ = 3.6V, V- = 0V	Full	-1		1	μA
Negative Supply Current	I-			-1		1	

Electrical Specifications - Single +3.3V Supply

(V+ = +3V to 3.6V, V- = 0V, GND = 0V, V_{NH} = 2.4V, V_{INL} = 0.8V)

Parameter	Symbol	Conditions	Temp (°C)	Min. ⁽¹⁾	Typ. ⁽²⁾	Max. ⁽¹⁾	Units
Analog Switch							
Analog Switch Range ⁽³⁾	V _{ANALOG}		Full	0		V+	V
Channel On-Resistance	R _{ON}	V+ = 3V, I _{COM} = -10mA V _{NO} = V _{NC} = 1.5V	25		62	150	Ω
			Full			200	
Dynamic							
Turn-On Time ⁽³⁾	t _{ON}	V _{COM} = 1.5V, Figure 2	25			400	ns
Turn-Off Time ⁽³⁾	t _{OFF}					150	
Break-Before-Make Time Delay	t _D	PS383 only	25	10	20		
Charge Injection	Q	C _L = 1nF, V _{GEN} = 0V, R _{GEN} = 0Ω	25			5	pC
Supply							
Power-Supply Range	V+		Full	2.7		16	V
Positive Supply Current	I+	All channels on or off, V _{IN} = 0V or V+, V+ = 3.6V, V- = 0.5V		-1		1	μA
Negative Supply Current	I-			-1		1	

Notes:

1. The algebraic convention, where the most negative value is a minimum and the most positive is a maximum, is used in this data sheet.
2. Typical values are for DESIGN AID ONLY, not guaranteed or subject to production testing.
3. Guaranteed by design
4. $\Delta R_{ON} = \Delta R_{ON \text{ max}} - \Delta R_{ON \text{ min}}$
5. Flatness is defined as the difference between the maximum and minimum value of on-resistance measured.
6. Leakage parameters are 100% tested at maximum rated hot temperature and guaranteed by correlation at +25°C.
7. Off Isolation = $20 \log_{10} [V_{COM} / (V_{NO} \text{ or } V_{NO})]$. See figure 5.
8. Between any two switches. See figure 6.
9. Leakage testing at single-supply is guaranteed by testing with dual supplies.

Typical Operating Characteristics ($T_A = +25^\circ\text{C}$, unless otherwise noted)

R_{ON} vs. V_{COM} & Supply Voltages

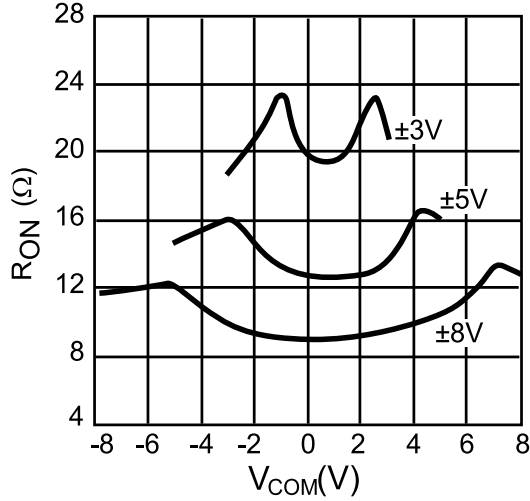

R_{ON} vs. V_{COM} & Supply Voltages

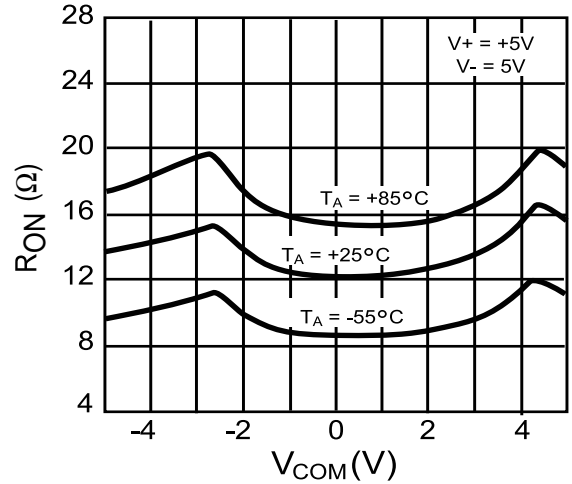

R_{ON} vs. V_{COM} (Single Supply)

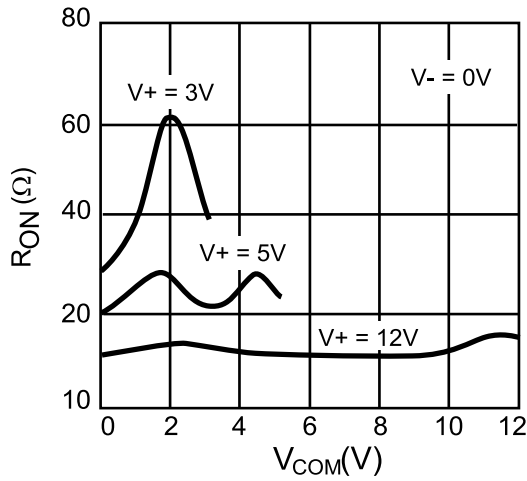

R_{ON} vs. V_{COM} and Temperature (Single Supply)

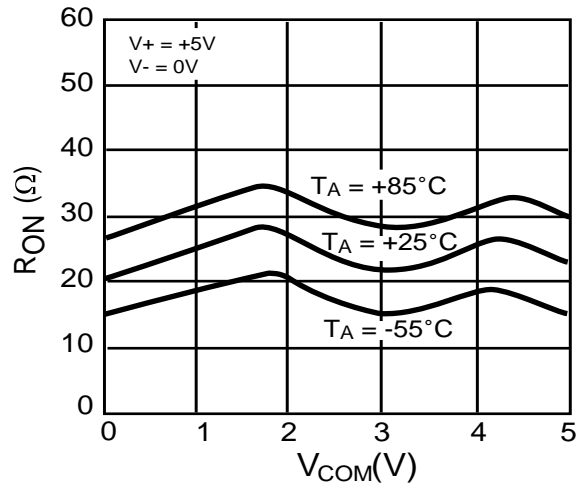

Charge Injection vs. Analog Voltage

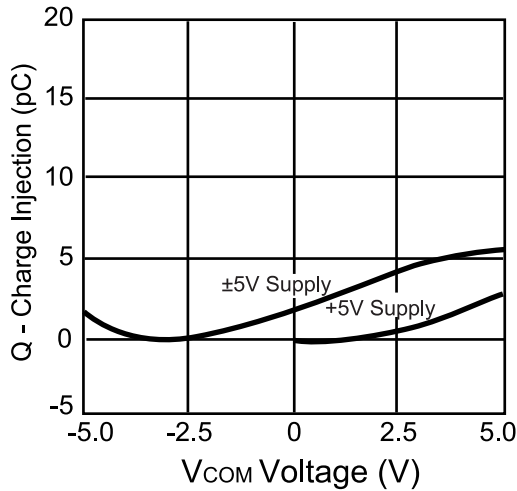

Leakage Current vs. V_{COM}

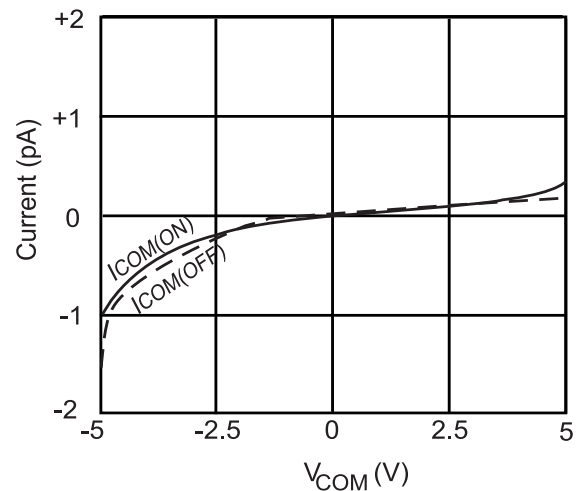

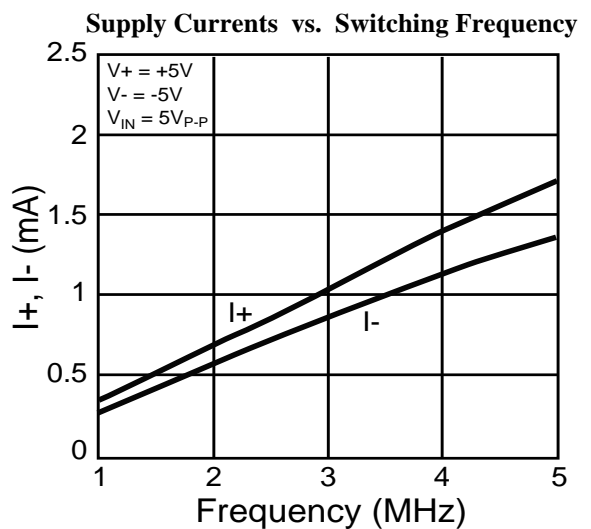
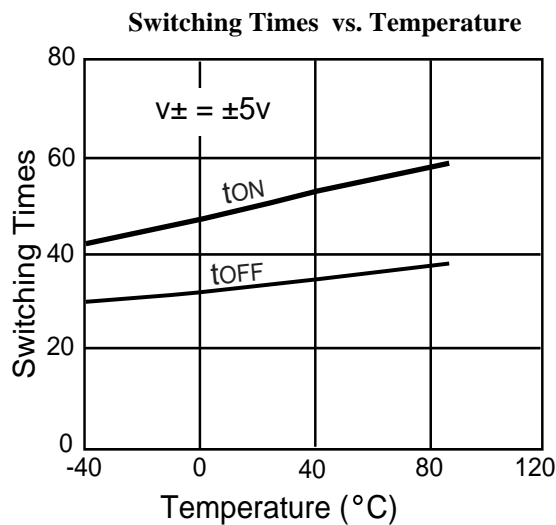
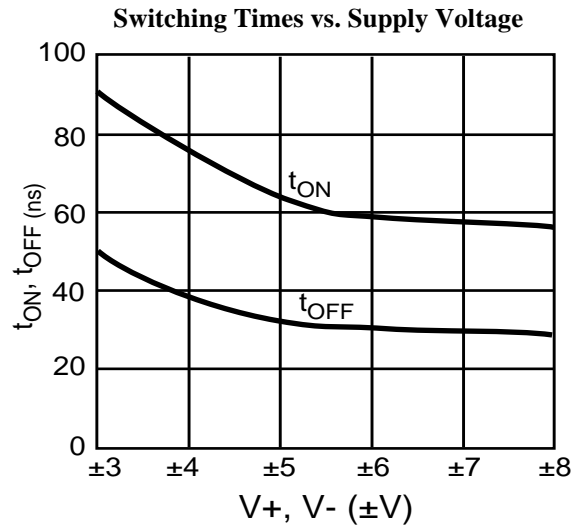
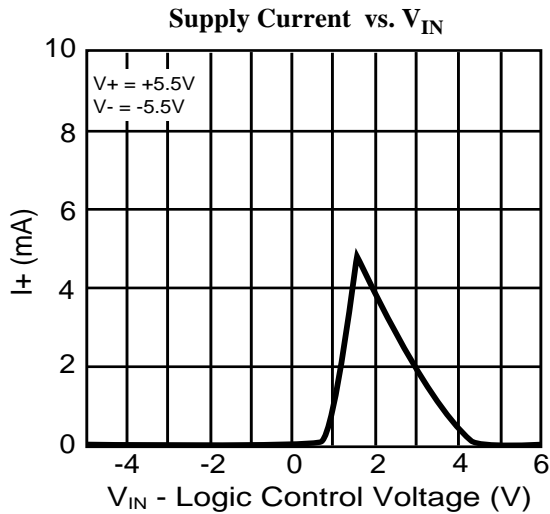
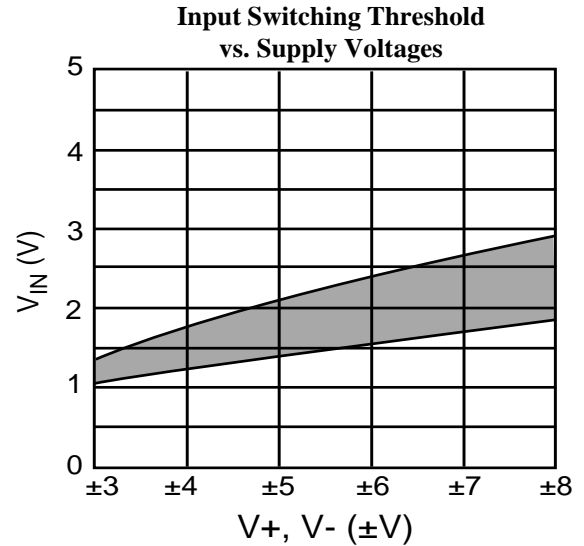
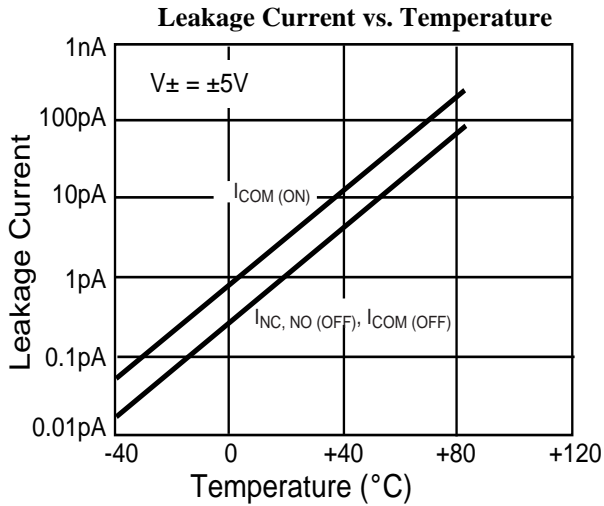
Typical Operating Characteristics (continued)

Test Circuits/Timing Diagrams

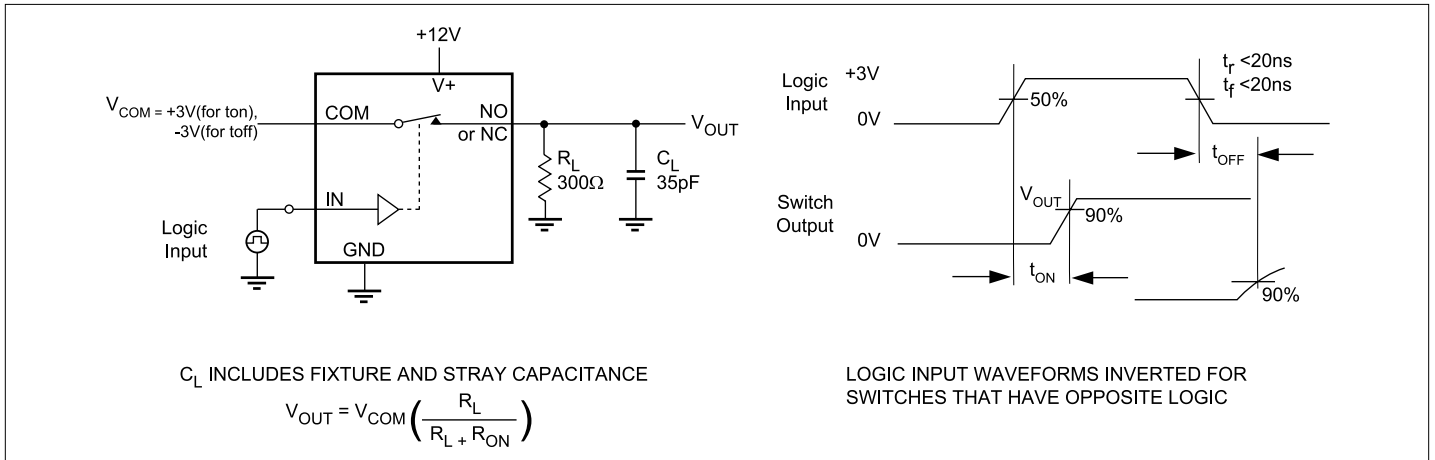

Figure 2. Switching Time

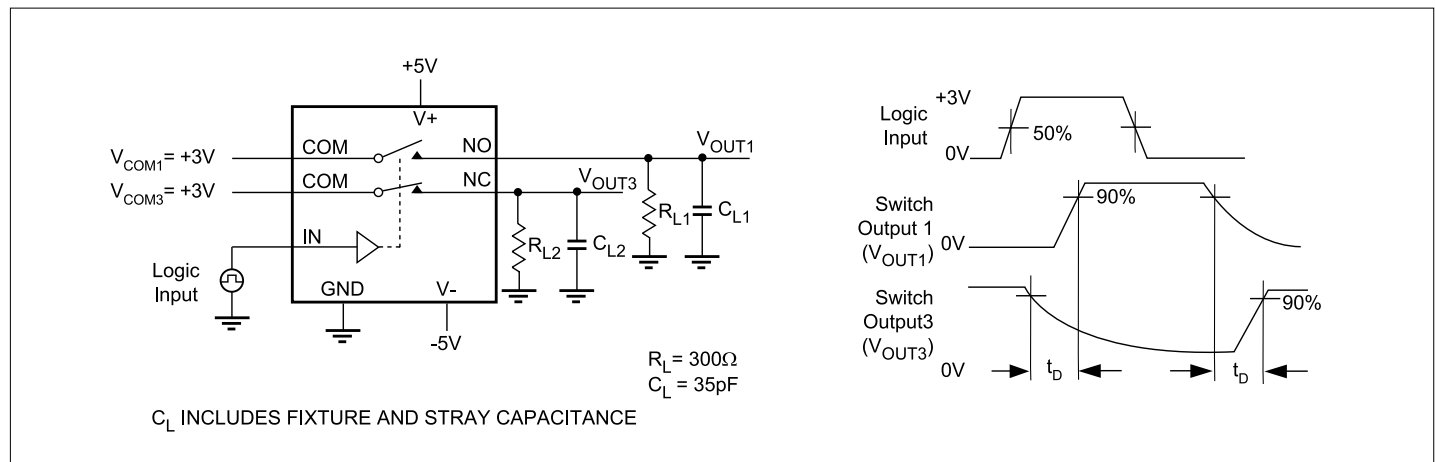

Figure 3. Break-Before-Make Interval (PS383 only)

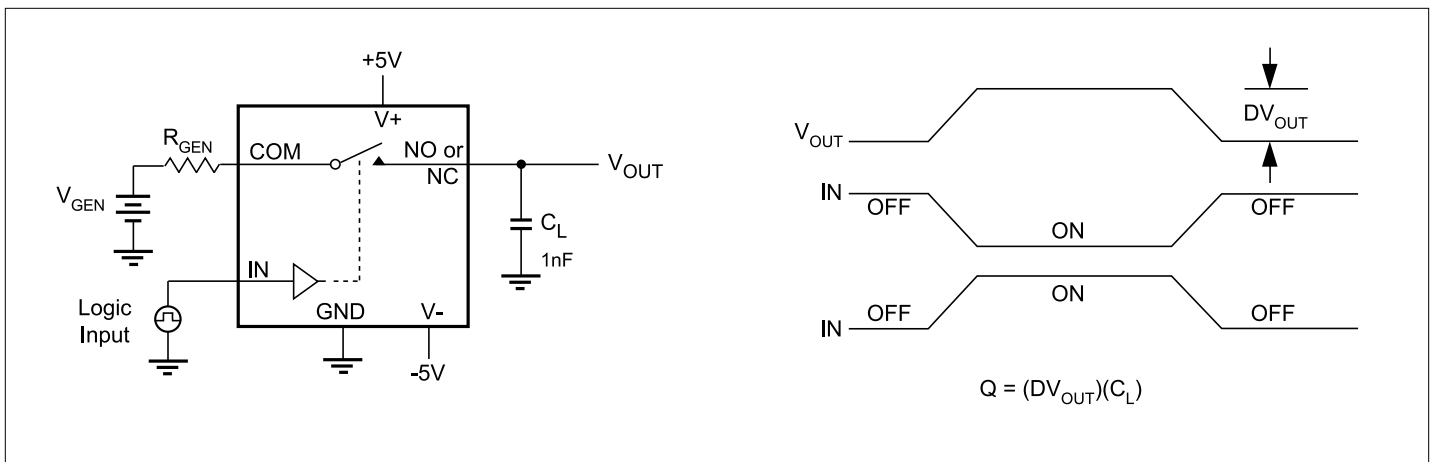

Figure 4. Charge Injection

Test Circuits/Timing Diagrams (continued)

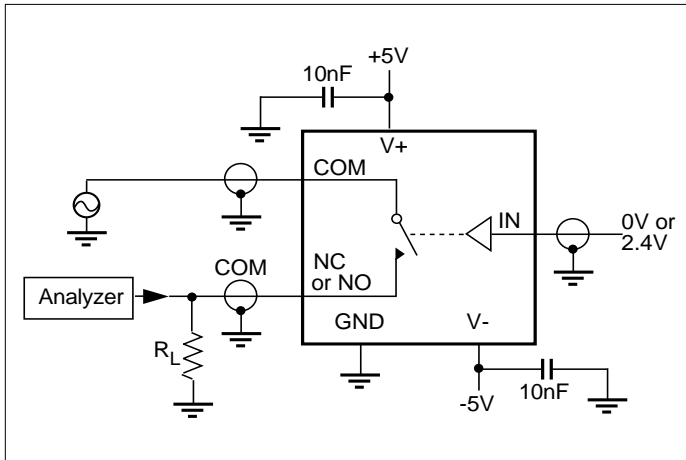

Figure 5. Off Isolation

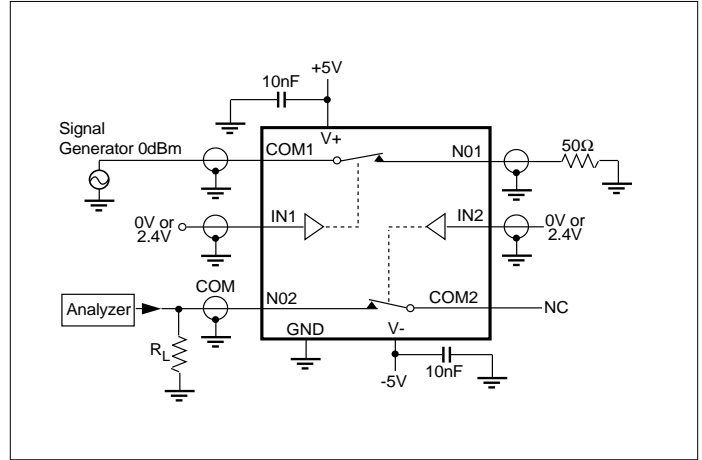

Figure 6. Crosstalk

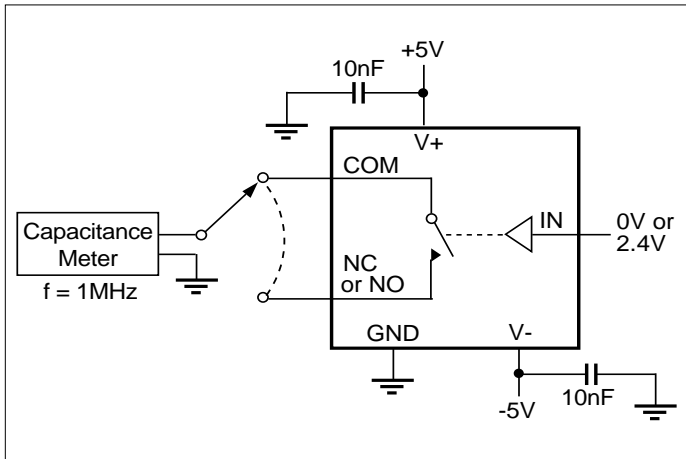

Figure 7. Channel-Off Capacitance

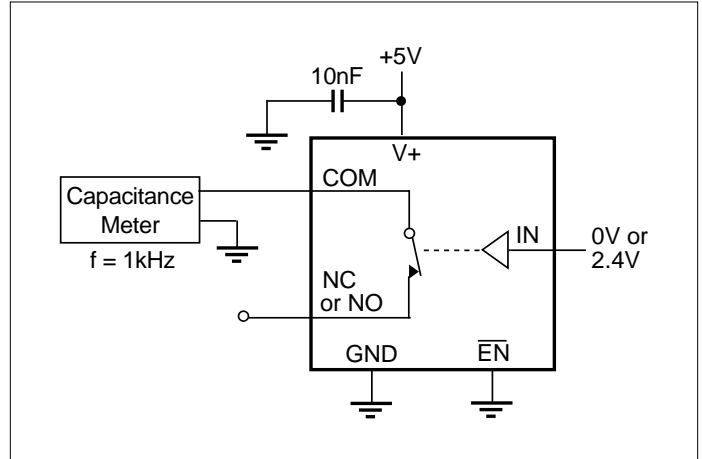

Figure 8. Channel-On Capacitance

Ordering Information

Part	Temp. Range	Package
PS381CPE	0°C to +70°C	16 Plastic DIP
PS381CSE	0°C to +70°C	16 Narrow SO
PS381EPE	-40°C to +85°C	16 Plastic DIP
PS381ESE	-40°C to +85°C	16 Narrow SO
PS383CPE	0°C to +70°C	16 Plastic DIP
PS383CSE	0°C to +70°C	16 Narrow SO
PS383EPE	-40°C to +85°C	16 Plastic DIP
PS383ESE	-40°C to +85°C	16 Narrow SO
PS385CPE	0°C to +70°C	16 Plastic DIP
PS385CSE	0°C to +70°C	16 Narrow SO
PS385EPE	-40°C to +85°C	16 Plastic DIP
PS385ESE	-40°C to +85°C	16 Narrow SO

Looking for pricing, stock, or lifecycle information?

Click below to explore more details on WIN SOURCE:

-  [View PS383ESE on WIN SOURCE](#)
-  [Diodes Incorporated Information](#)

Optimize Your Supply Chain with WIN SOURCE Solutions

-  Global Sourcing Solution
-  Obsolete Management
-  Cost Control Management
-  Shortage Management
-  Alternative Solution
-  Excess Inventory Management