



**THE DATASHEET OF
MRF6VP121KHR6**



RF Power Field Effect Transistors

N-Channel Enhancement-Mode Lateral MOSFETs

RF Power transistors designed for applications operating at frequencies between 965 and 1215 MHz. These devices are suitable for use in pulsed applications.

- Typical Pulsed Performance: $V_{DD} = 50$ Volts, $I_{DQ} = 150$ mA, $P_{out} = 1000$ Watts Peak (100 W Avg.), $f = 1030$ MHz, Pulse Width = 128 μ sec, Duty Cycle = 10%
 Power Gain — 20 dB
 Drain Efficiency — 56%
- Capable of Handling 5:1 VSWR, @ 50 Vdc, 1030 MHz, 1000 Watts Peak Power

Features

- Characterized with Series Equivalent Large-Signal Impedance Parameters
- Internally Matched for Ease of Use
- Qualified Up to a Maximum of 50 V_{DD} Operation
- Integrated ESD Protection
- Designed for Push-Pull Operation
- Greater Negative Gate-Source Voltage Range for Improved Class C Operation
- RoHS Compliant
- In Tape and Reel. R6 Suffix = 150 Units per 56 mm, 13 inch Reel.

MRF6VP121KHR6
MRF6VP121KHSR6

965-1215 MHz, 1000 W, 50 V
LATERAL N-CHANNEL
BROADBAND
RF POWER MOSFETs

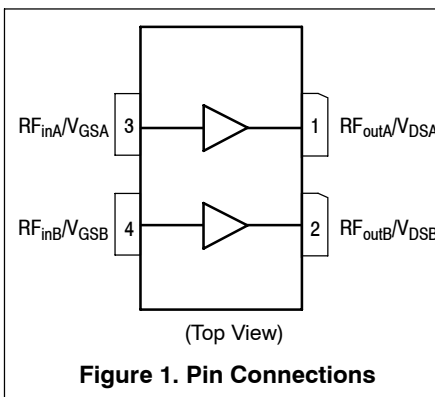
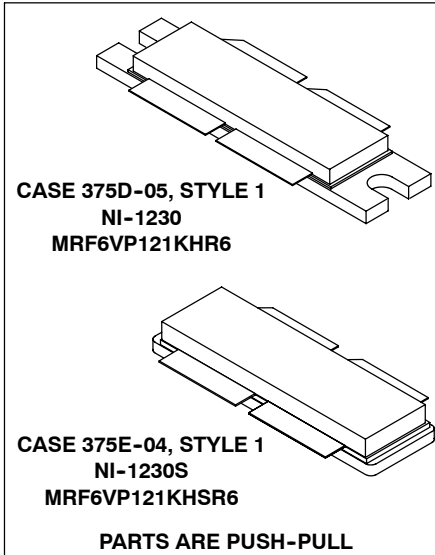

Table 1. Maximum Ratings

Rating	Symbol	Value	Unit
Drain-Source Voltage	V_{DSS}	-0.5, +110	Vdc
Gate-Source Voltage	V_{GS}	-6.0, +10	Vdc
Storage Temperature Range	T_{stg}	-65 to +150	$^{\circ}$ C
Case Operating Temperature	T_C	150	$^{\circ}$ C
Operating Junction Temperature (1,2)	T_J	225	$^{\circ}$ C

1. Continuous use at maximum temperature will affect MTTF.
 2. MTTF calculator available at <http://www.freescale.com/rtf>. Select Software & Tools/Development Tools/Calculators to access MTTF calculators by product.

Table 2. Thermal Characteristics

Characteristic	Symbol	Value (1,2)	Unit
Thermal Resistance, Junction to Case Case Temperature 67°C, 1000 W Pulsed, 128 μ sec Pulse Width, 10% Duty Cycle, 50 Vdc, $I_{DQ} = 150$ mA	$Z_{\theta JC}$	0.02	°C/W
Case Temperature 62°C, Mode-S Pulse Train, 80 Pulses of 32 μ sec On, 18 μ sec Off, Repeated Every 40 msec, 6.4% Overall Duty Cycle, 50 Vdc, $I_{DQ} = 150$ mA		0.07	

Table 3. ESD Protection Characteristics

Test Methodology	Class
Human Body Model (per JESD22-A114)	1B (Minimum)
Machine Model (per EIA/JESD22-A115)	B (Minimum)
Charge Device Model (per JESD22-C101)	IV (Minimum)

Table 4. Electrical Characteristics ($T_A = 25^\circ\text{C}$ unless otherwise noted)

Characteristic	Symbol	Min	Typ	Max	Unit
----------------	--------	-----	-----	-----	------

Off Characteristics (3)

Gate-Source Leakage Current ($V_{GS} = 5$ Vdc, $V_{DS} = 0$ Vdc)	I_{GSS}	—	—	10	μ Adc
Drain-Source Breakdown Voltage ($V_{GS} = 0$ Vdc, $I_D = 165$ mA)	$V_{(BR)DSS}$	110	—	—	Vdc
Zero Gate Voltage Drain Leakage Current ($V_{DS} = 50$ Vdc, $V_{GS} = 0$ Vdc)	I_{DSS}	—	—	10	μ Adc
Zero Gate Voltage Drain Leakage Current ($V_{DS} = 100$ Vdc, $V_{GS} = 0$ Vdc)	I_{DSS}	—	—	100	μ Adc

On Characteristics

Gate Threshold Voltage (3) ($V_{DS} = 10$ Vdc, $I_D = 1000$ μ Adc)	$V_{GS(th)}$	0.9	1.6	2.4	Vdc
Gate Quiescent Voltage (4) ($V_{DD} = 50$ Vdc, $I_D = 150$ mA, Measured in Functional Test)	$V_{GS(Q)}$	1.5	2.2	3	Vdc
Drain-Source On-Voltage (3) ($V_{GS} = 10$ Vdc, $I_D = 2.7$ Adc)	$V_{DS(on)}$	—	0.15	—	Vdc

Dynamic Characteristics (3)

Reverse Transfer Capacitance ($V_{DS} = 50$ Vdc \pm 30 mV(rms)ac @ 1 MHz, $V_{GS} = 0$ Vdc)	C_{rss}	—	1.27	—	pF
Output Capacitance ($V_{DS} = 50$ Vdc \pm 30 mV(rms)ac @ 1 MHz, $V_{GS} = 0$ Vdc)	C_{oss}	—	86.7	—	pF
Input Capacitance ($V_{DS} = 50$ Vdc, $V_{GS} = 0$ Vdc \pm 30 mV(rms)ac @ 1 MHz)	C_{iss}	—	539	—	pF

Functional Tests (4) (In Freescale Test Fixture, 50 ohm system) $V_{DD} = 50$ Vdc, $I_{DQ} = 150$ mA, $P_{out} = 1000$ W Peak (100 W Avg.), $f = 1030$ MHz, 128 μ sec Pulse Width, 10% Duty Cycle

Power Gain	G_{ps}	19	20	22	dB
Drain Efficiency	η_D	54	56	—	%
Input Return Loss	IRL	—	-23	-9	dB

1. MTF calculator available at <http://www.freescale.com/rf>. Select Software & Tools/Development Tools/Calculators to access MTF calculators by product.
2. Refer to AN1955, *Thermal Measurement Methodology of RF Power Amplifiers*. Go to <http://www.freescale.com/rf>. Select Documentation/Application Notes – AN1955.
3. Each side of device measured separately.
4. Measurement made with device in push-pull configuration.

(continued)

Table 4. Electrical Characteristics ($T_A = 25^\circ\text{C}$ unless otherwise noted) (continued)

Characteristic	Symbol	Min	Typ	Max	Unit
----------------	--------	-----	-----	-----	------

Pulsed RF Performance — 785 MHz (In Freescale 785 MHz Test Fixture, 50 ohm system) $V_{DD} = 50\text{ Vdc}$, $I_{DQ} = 150\text{ mA}$, $P_{out} = 1000\text{ W}$ Peak (100 W Avg.), $f = 785\text{ MHz}$, 128 μsec Pulse Width, 10% Duty Cycle

Power Gain	G_{ps}	—	18.9	—	dB
Drain Efficiency	η_D	—	57.8	—	%
Input Return Loss	IRL	—	-16.6	—	dB

Pulsed RF Performance — 1030 MHz (In Freescale 1030 MHz Test Fixture, 50 ohm system) $V_{DD} = 50\text{ Vdc}$, $I_{DQ} = 150\text{ mA}$, $P_{out} = 1000\text{ W}$ Peak (100 W Avg.), $f = 1030\text{ MHz}$, Mode-S Pulse Train, 80 Pulses of 32 μsec On, 18 μsec Off, Repeated Every 40 msec, 6.4% Overall Duty Cycle

Power Gain	G_{ps}	—	19.8	—	dB
Drain Efficiency	η_D	—	59.0	—	%
Burst Droop	BD_{rp}	—	0.21	—	dB

Pulsed RF Performance — 1090 MHz (In Freescale 1090 MHz Test Fixture, 50 ohm system) $V_{DD} = 50\text{ Vdc}$, $I_{DQ} = 150\text{ mA}$, $P_{out} = 1000\text{ W}$ Peak (100 W Avg.), $f = 1090\text{ MHz}$, 128 μsec Pulse Width, 10% Duty Cycle

Power Gain	G_{ps}	—	21.4	—	dB
Drain Efficiency	η_D	—	56.3	—	%
Input Return Loss	IRL	—	-25.3	—	dB

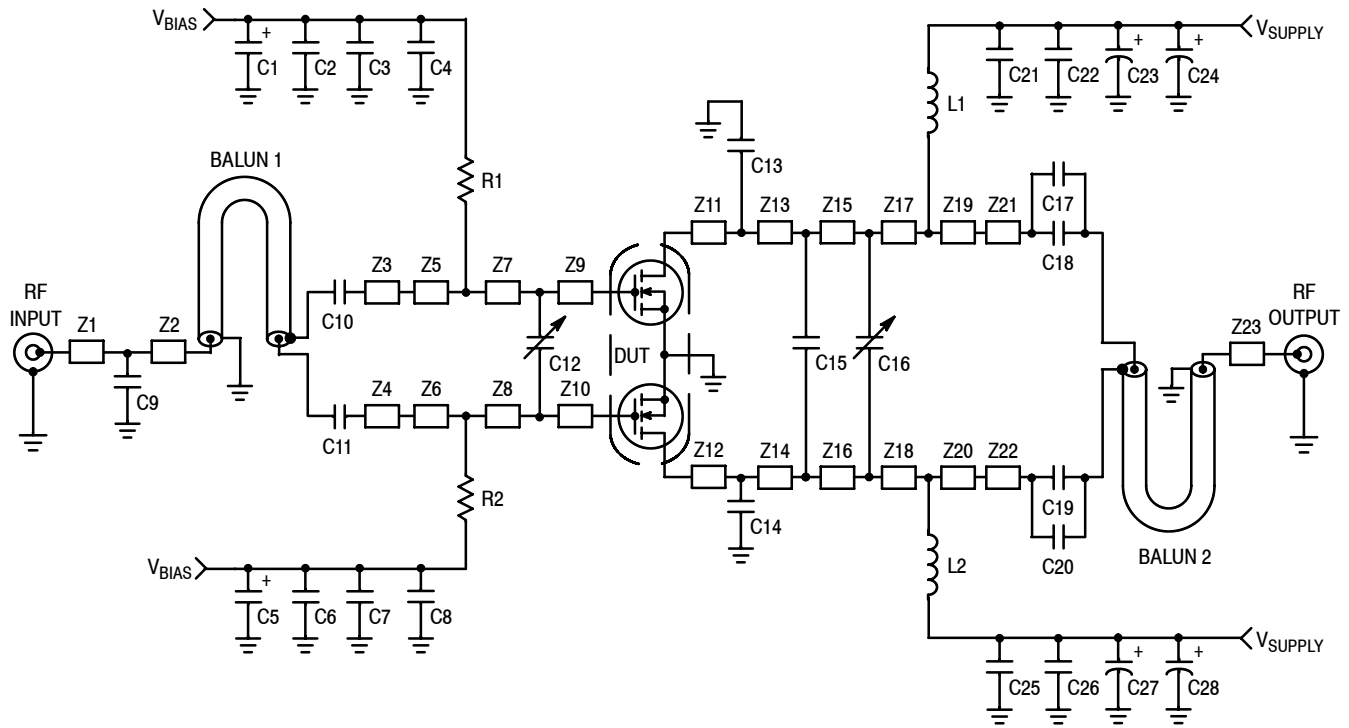

Z1	0.140" x 0.083"	Z13, Z14	0.143" x 0.631"
Z2	0.300" x 0.083"	Z15, Z16	0.135" x 0.631"
Z3, Z4	0.746" x 0.220"	Z17, Z18	0.102" x 0.632"
Z5, Z6	0.075" x 0.631"	Z19, Z20	0.130" x 0.631"
Z7, Z8	0.329" x 0.631"	Z21, Z22	0.736" x 0.215"
Z9, Z10	0.326" x 0.631"	Z23	0.410" x 0.083"
Z11, Z12	0.240" x 0.631"	PCB	Arlon CuClad 250GX-0300-55-22, 0.030", $\epsilon_r = 2.55$

Figure 2. MRF6VP121KHR6(HSR6) Test Circuit Schematic

Table 5. MRF6VP121KHR6(HSR6) Test Circuit Component Designations and Values

Part	Description	Manufacturer	Part Number
Balun 1, 2	Balun Anaren	3A412	Anaren
C1, C5	22 μ F, 25 V Tantalum Capacitors	TPSD226M025R	AVX
C2, C6	2.2 μ F, 50 V Chip Capacitors	C1825C225J5RAC	Kemet
C3, C7	0.22 μ F, 100 V Chip Capacitors	C1210C224K1RAC	Kemet
C4, C8, C10, C11, C17, C18, C19, C20, C21, C25	36 pF Chip Capacitors	ATC100B360JT500XT	ATC
C9	1.0 pF Chip Capacitor	ATC100B1R0CT500XT	ATC
C12, C16	0.8-8.0 pF Variable Capacitors	27291SL	Johanson
C13, C14, C15	5.1 pF Chip Capacitors	ATC100B5R1CT500XT	ATC
C22, C26	0.022 μ F, 100 V Chip Capacitors	C1825C223K1GAC	Kemet
C23, C24, C27, C28	470 μ F, 63 V Electrolytic Capacitors	MCGPR63V477M13X26-RH	Multicomp
L1, L2	Inductors 3 Turn	GA3094-AL	Coilcraft
R1, R2	1000 Ω , 1/4 W Chip Resistors	CRCW12061001FKEA	Vishay

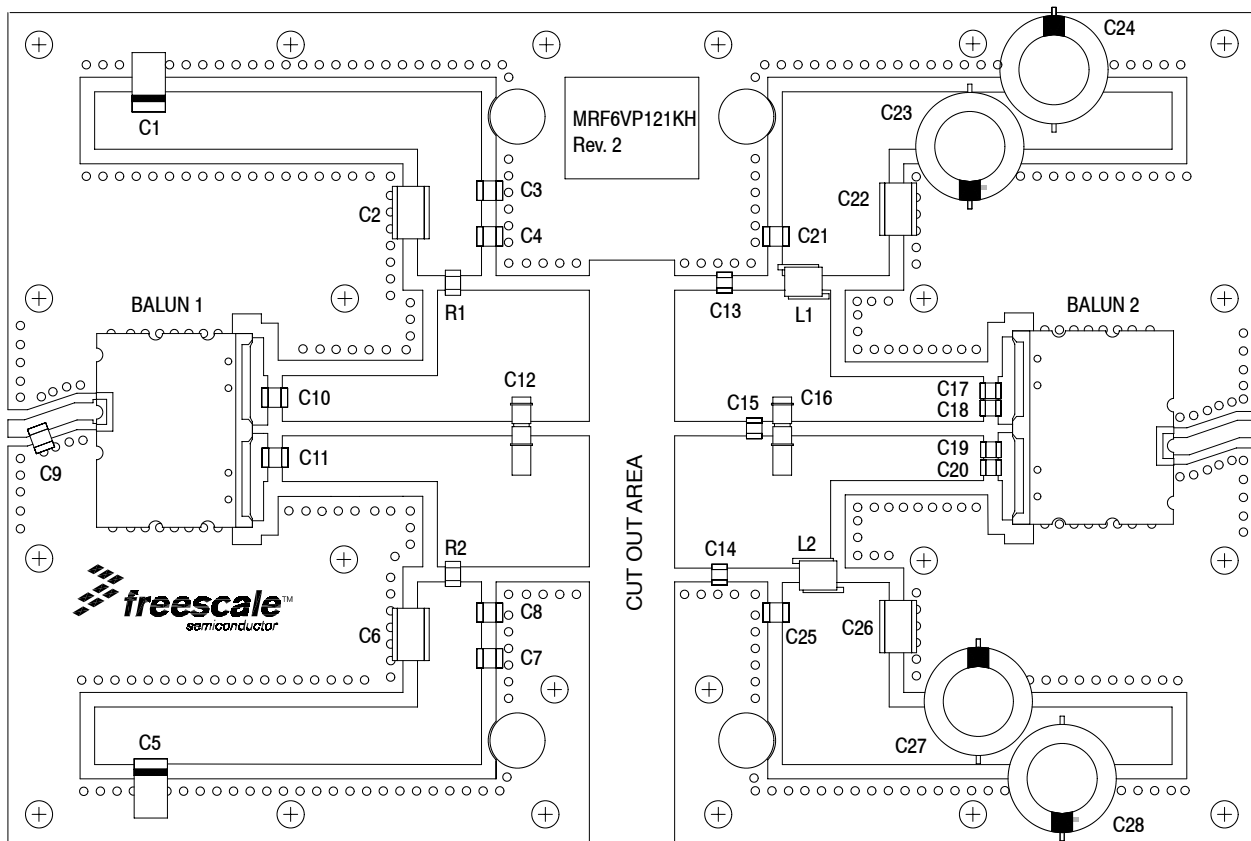
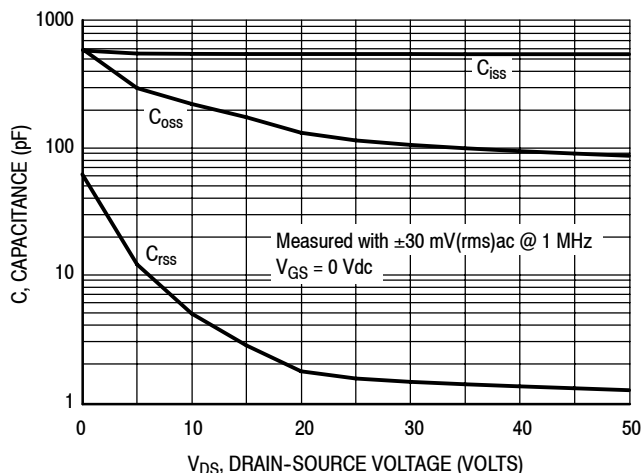

Figure 3. MRF6VP121KHR6(HSR6) Test Circuit Component Layout

TYPICAL CHARACTERISTICS



Note: Each side of device measured separately.
Figure 4. Capacitance versus Drain-Source Voltage

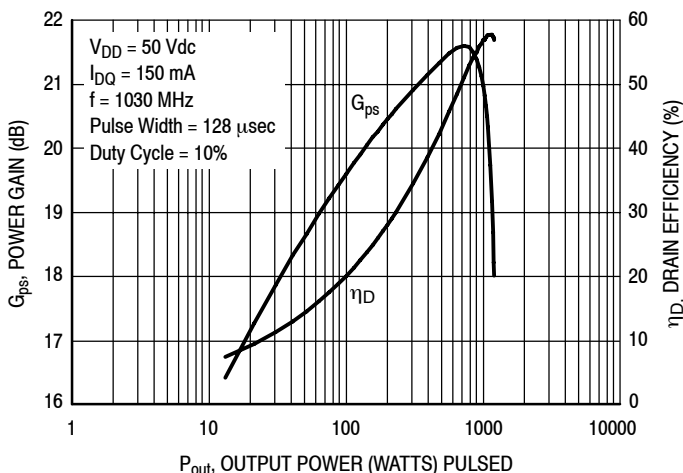

Figure 5. Pulsed Power Gain and Drain Efficiency versus Output Power

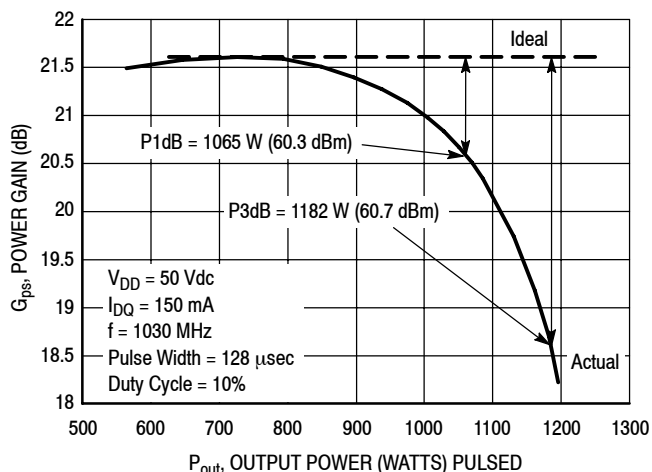

Figure 6. Pulsed Power Gain versus Output Power

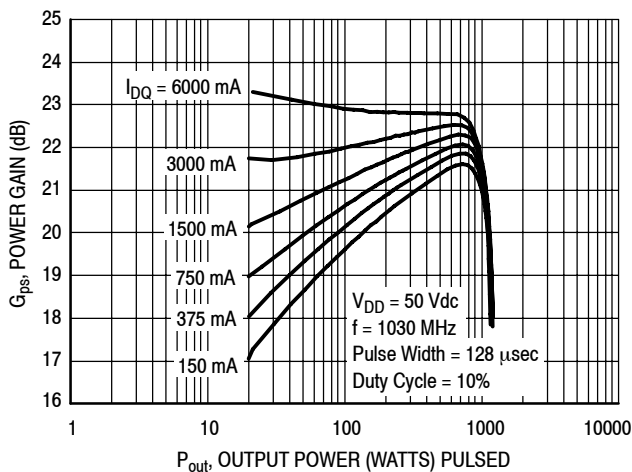

Figure 7. Pulsed Power Gain versus Output Power

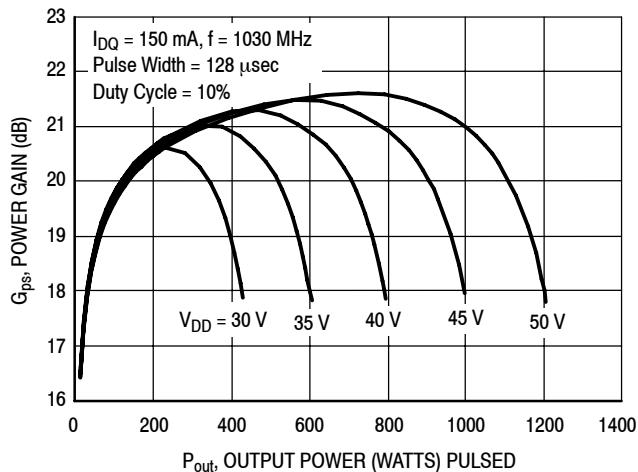

Figure 8. Pulsed Power Gain versus Output Power

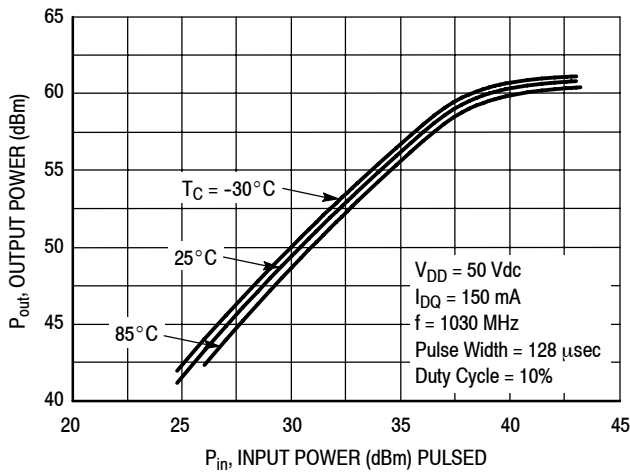

Figure 9. Pulsed Output Power versus Input Power

TYPICAL CHARACTERISTICS

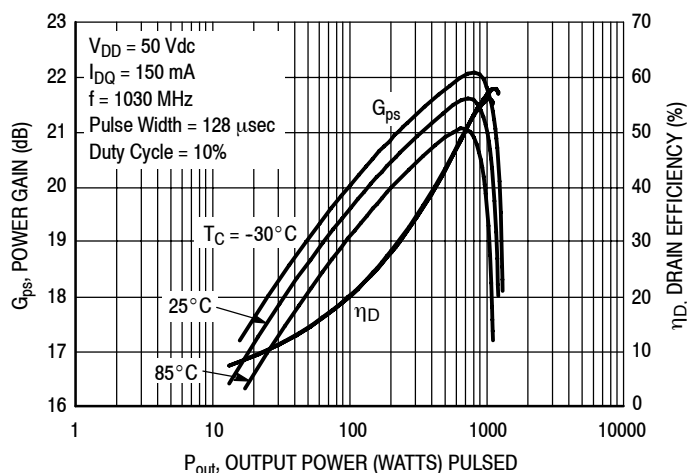
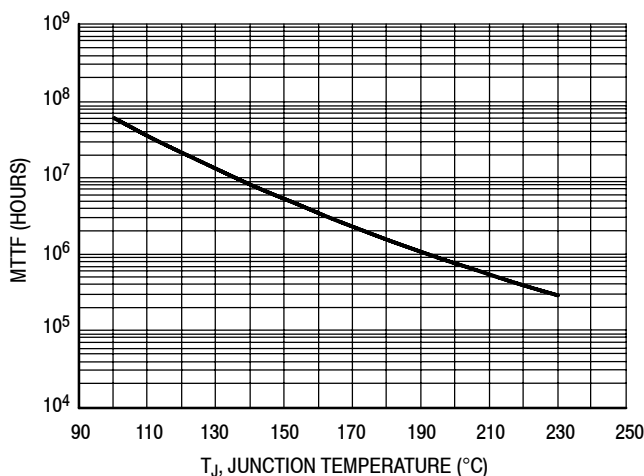

Figure 10. Pulsed Power Gain and Drain Efficiency versus Output Power



This above graph displays calculated MTTF in hours when the device is operated at $V_{DD} = 50$ Vdc, $P_{out} = 1000$ W Peak, Pulse Width = 128 μ sec, Duty Cycle = 10%, and $\eta_D = 56\%$.

MTTF calculator available at <http://www.freescale.com/rf>. Select Software & Tools/Development Tools/Calculators to access MTTF calculators by product.

Figure 11. MTTF versus Junction Temperature - 128 μ sec, 10% Duty Cycle

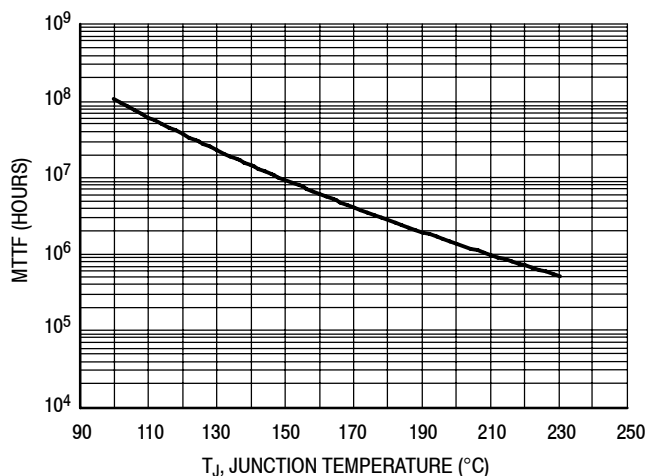

This above graph displays calculated MTTF in hours when the device is operated at $V_{DD} = 50$ Vdc, $P_{out} = 1000$ W Peak, Mode-S Pulse Train, Pulse Width = 32 μ sec, Duty Cycle = 6.4%, and $\eta_D = 59\%$.

MTTF calculator available at <http://www.freescale.com/rf>. Select Software & Tools/Development Tools/Calculators to access MTTF calculators by product.

Figure 12. MTTF versus Junction Temperature - Mode-S

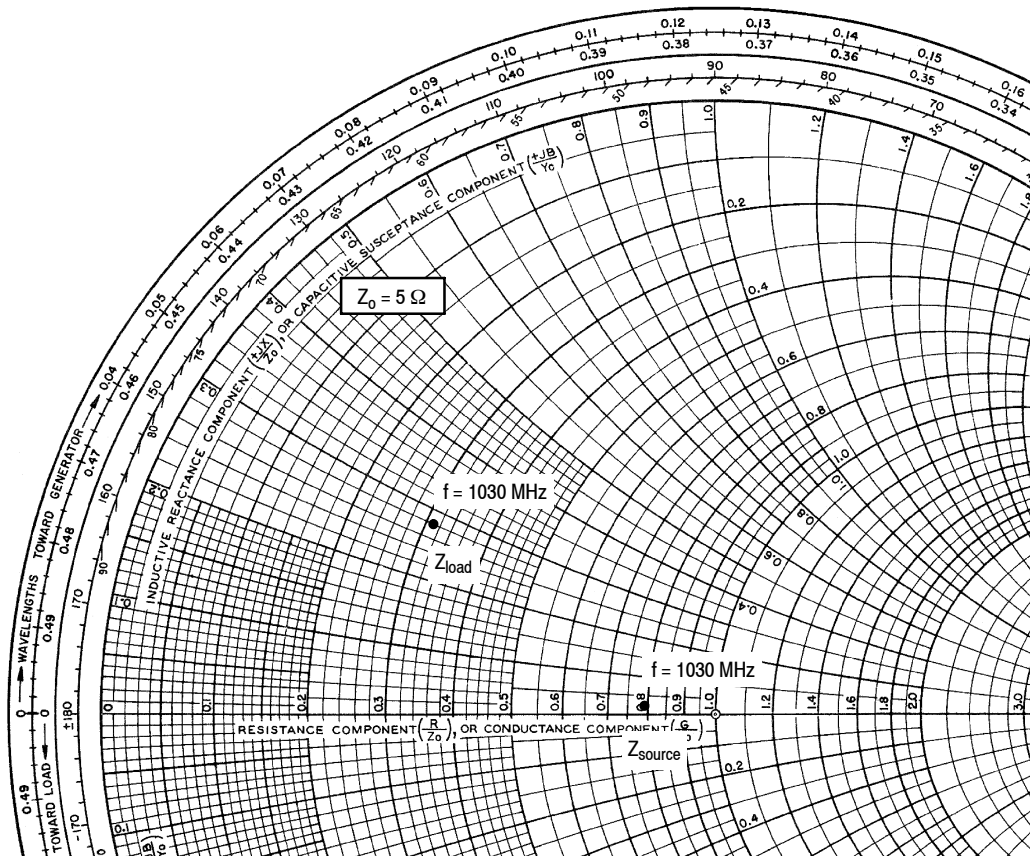

$V_{DD} = 50 \text{ Vdc}$, $I_{DQ} = 150 \text{ mA}$, $P_{out} = 1000 \text{ W Peak}$

f MHz	Z_{source} Ω	Z_{load} Ω
1030	$3.93 + j0.09$	$1.54 + j1.42$

Z_{source} = Test circuit impedance as measured from gate to gate, balanced configuration.

Z_{load} = Test circuit impedance as measured from drain to drain, balanced configuration.

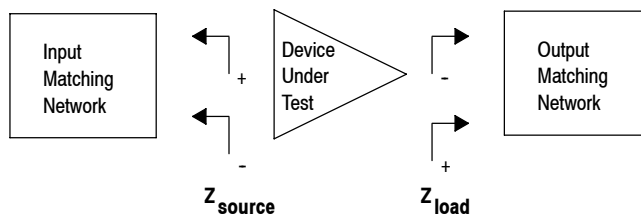

Figure 13. Series Equivalent Source and Load Impedance

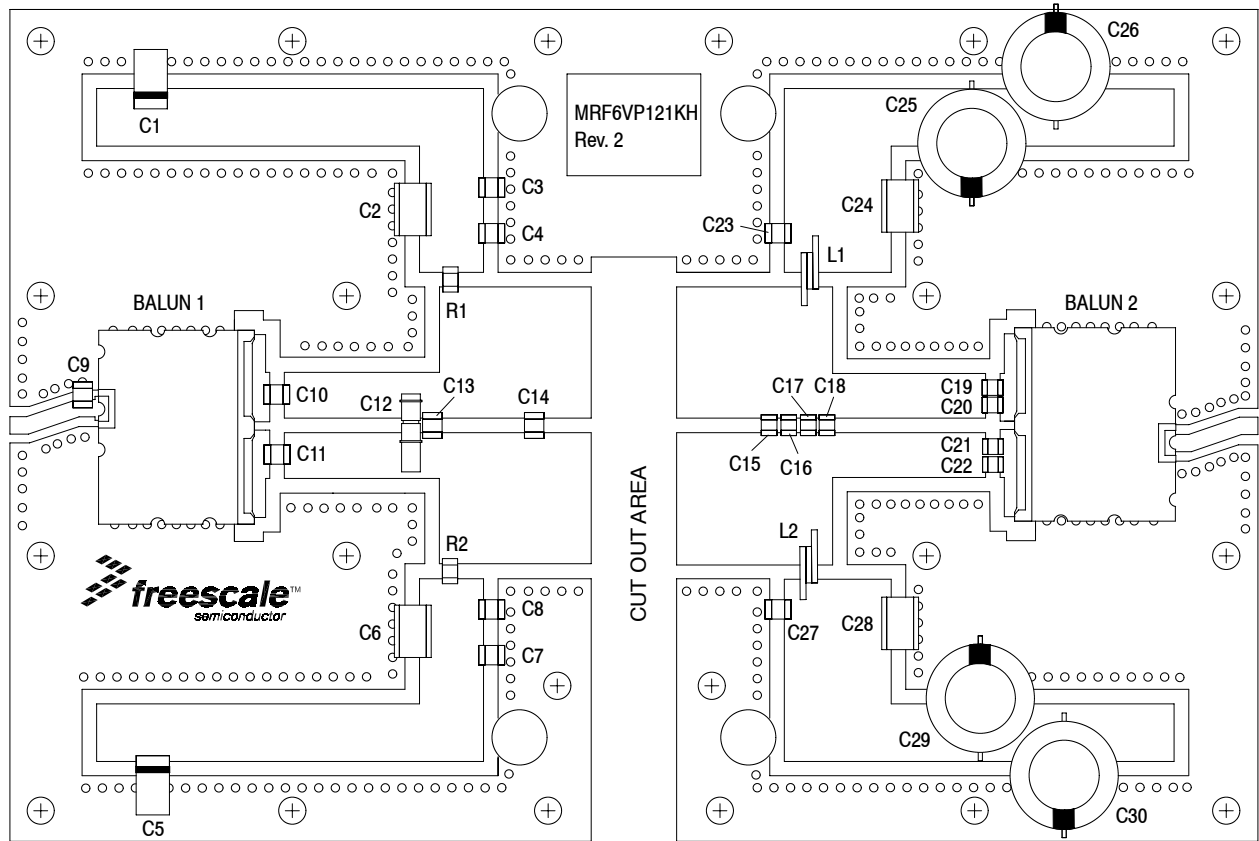

Figure 14. MRF6VP121KHR6(HSR6) Test Circuit Component Layout — 785 MHz

Table 6. MRF6VP121KHR6(HSR6) Test Circuit Component Designations and Values — 785 MHz

Part	Description	Manufacturer	Part Number
Balun 1, 2	Balun Anaren	3A412	Anaren
C1, C5	22 μ F, 25 V Tantalum Capacitors	TPSD226M025R0200	AVX
C2, C6	2.2 μ F, 50 V Chip Capacitors	C1825C225J5RAC-TU	Kemet
C3, C7	0.22 μ F, 100 V Chip Capacitors	C1210C224K1RAC-TU	Kemet
C4, C8, C10, C11, C19, C20, C21, C22, C23, C27	36 pF Chip Capacitors	ATC100B360JT500XT	ATC
C9	8.2 pF Chip Capacitor	ATC100B8R2CT500XT	ATC
C12	0.6–4.5 pF Variable Capacitor	27271SL	Johanson
C13	3.6 pF Chip Capacitor	ATC100B3R6CT500XT	ATC
C14	10 pF Chip Capacitor	ATC100B100JT500XT	ATC
C15, C16, C17, C18	5.1 pF Chip Capacitors	ATC100B5R1CT500XT	ATC
C24, C28	0.022 μ F, 100 V Chip Capacitors	C1825C223K1GAC	Kemet
C25, C26, C29, C30	470 μ F, 63 V Electrolytic Capacitors	MCGPR63V477M13X26-RH	Multicomp
L1, L2	Inductors 3 Turn	GA3094-ALC	Coilcraft
R1, R2	1000 Ω , 1/4 W Chip Resistors	CRCW12061K00FKEA	Vishay
PCB	CuClad, 0.030", $\epsilon_r = 2.55$	250GX-0300-55-22	Arlon

TYPICAL CHARACTERISTICS — 785 MHZ

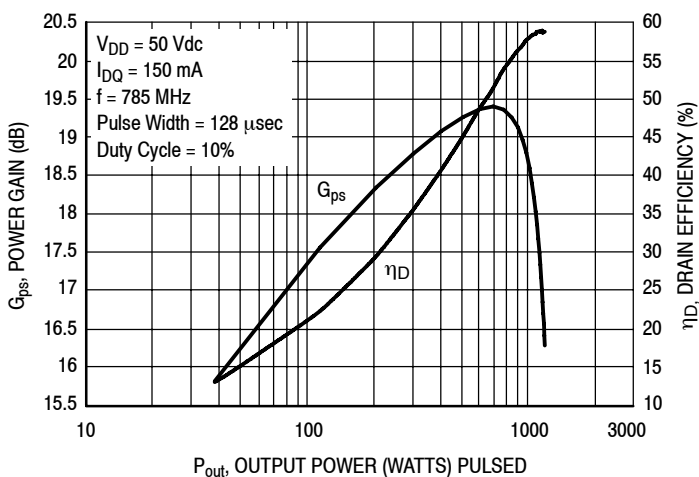
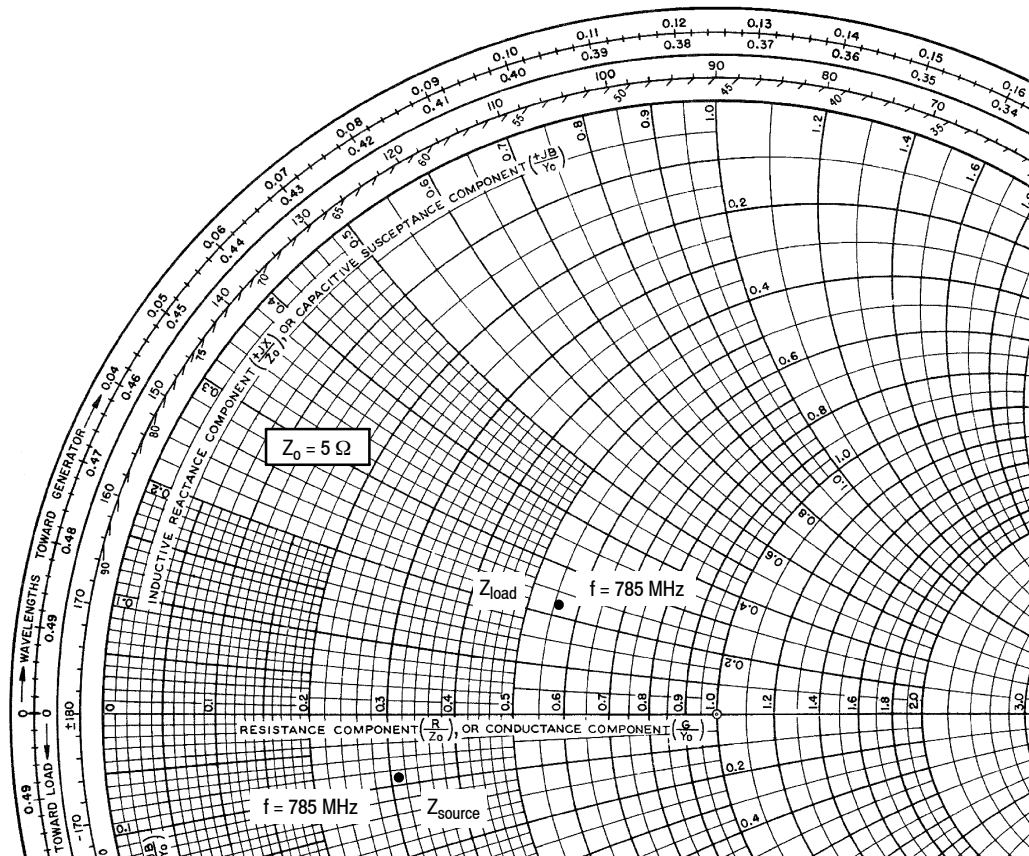

Figure 15. Pulsed Power Gain and Drain Efficiency versus Output Power



$V_{DD} = 50 \text{ Vdc}$, $I_{DQ} = 150 \text{ mA}$, $P_{out} = 1000 \text{ W Peak}$

f MHz	Z_{source} Ω	Z_{load} Ω
785	$1.54 - j0.46$	$2.79 + j1.10$

Z_{source} = Test circuit impedance as measured from gate to gate, balanced configuration.

Z_{load} = Test circuit impedance as measured from drain to drain, balanced configuration.

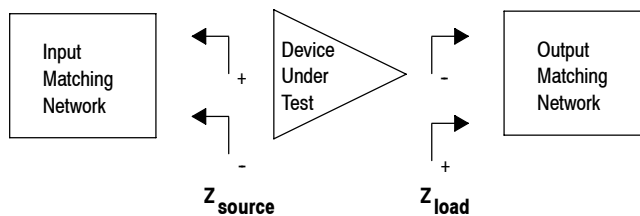

Figure 16. Series Equivalent Source and Load Impedance — 785 MHz

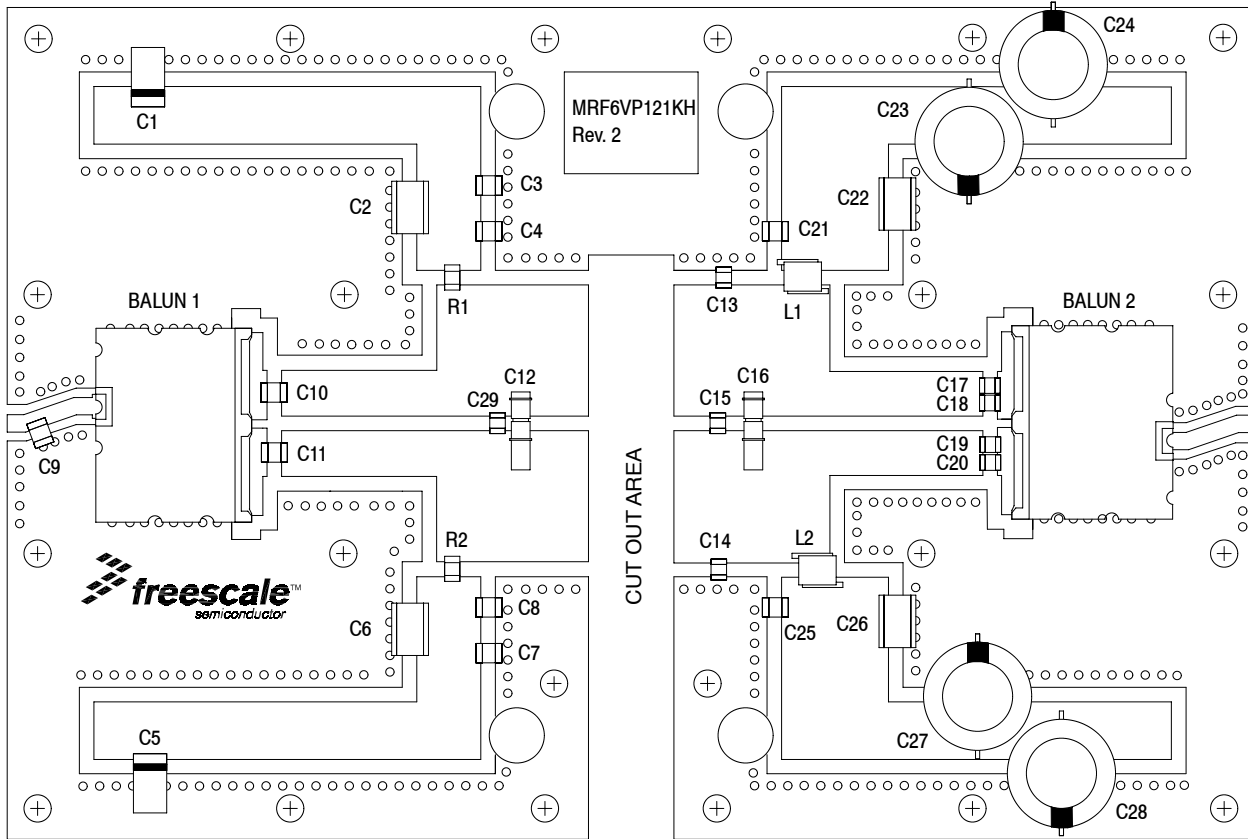

Figure 17. MRF6VP121KHR6(HSR6) Test Circuit Component Layout — 1090 MHz

Table 7. MRF6VP121KHR6(HSR6) Test Circuit Component Designations and Values — 1090 MHz

Part	Description	Manufacturer	Part Number
Balun 1, 2	Balun Anaren	3A412	Anaren
C1, C5	22 μ F, 25 V Tantalum Capacitors	TPSD226M025R0200	AVX
C2, C6	2.2 μ F, 50 V 1825 Chip Capacitors	C1825C225J5RAC-TU	Kemet
C3, C7	0.22 μ F, 100 V Chip Capacitors	C1210C224K1RAC-TU	Kemet
C4, C8, C17, C18, C19, C20, C21, C25	36 pF Chip Capacitors	ATC100B360JT500XT	ATC
C9	1.0 pF Chip Capacitor	ATC100B1R0BT500XT	ATC
C12, C16	0.8–8.0 pF Variable Capacitors	27291SL	Johanson
C10, C11, C13, C14, C15, C29	5.1 pF Chip Capacitors	ATC100B5R1CT500XT	ATC
C22, C26	0.022 μ F, 100 V Chip Capacitors	C1825C223K1GAC	Kemet
C23, C24, C27, C28	470 μ F, 63 V Electrolytic Capacitors	MCGPR63V477M13X26-RH	Multicomp
L1, L2	Inductors 3 Turn	GA3094-ALC	Coilcraft
R1, R2	1000 Ω , 1/4 W Chip Resistors	CRCW12061K00FKEA	Vishay
PCB	CuClad, 0.030", $\epsilon_r = 2.55$	250GX-0300-55-22	Arlon

TYPICAL CHARACTERISTICS — 1090 MHZ

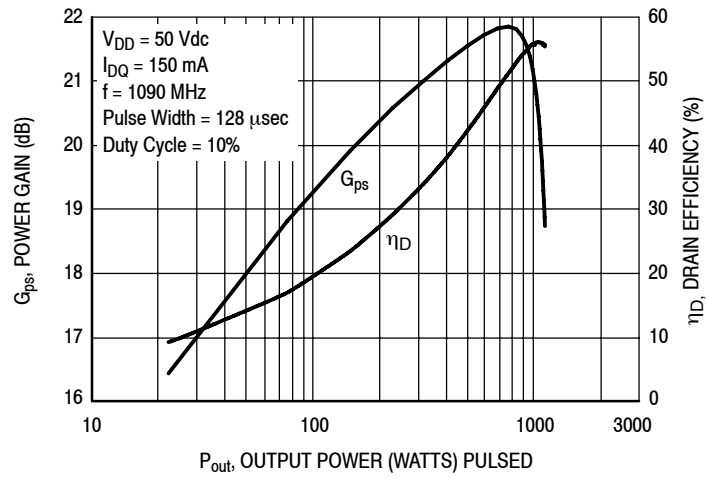
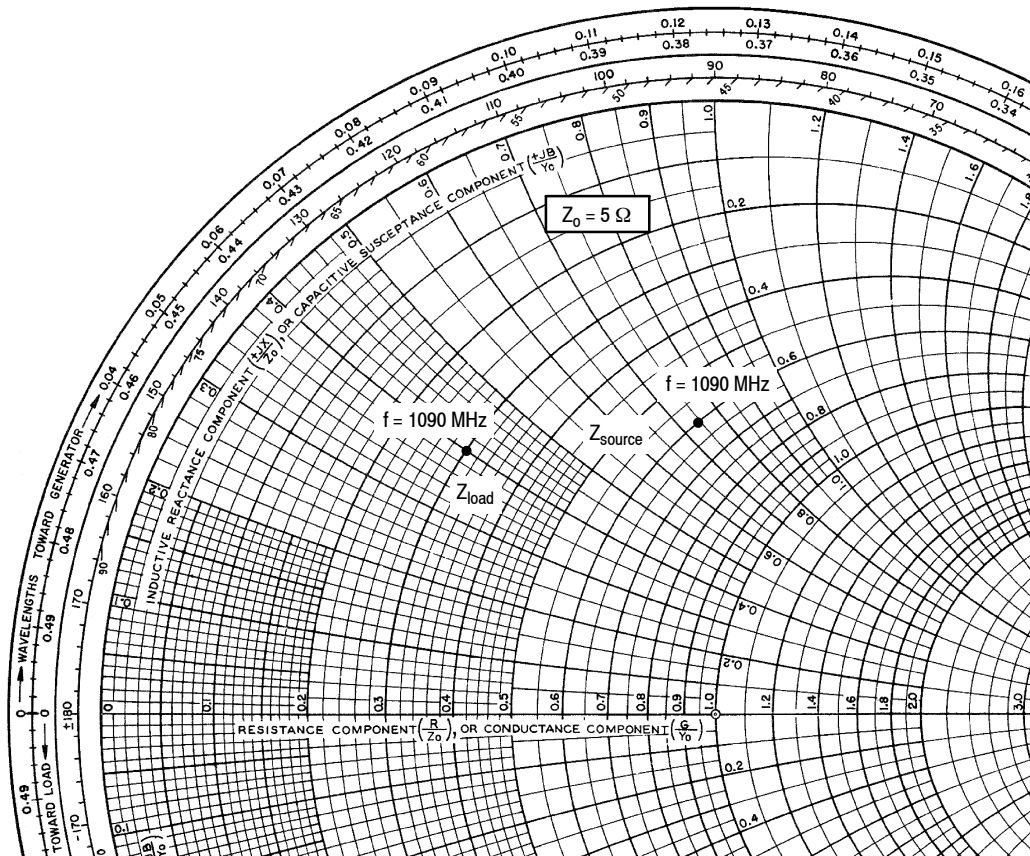

Figure 18. Pulsed Power Gain and Drain Efficiency versus Output Power



$V_{DD} = 50 \text{ Vdc}$, $I_{DQ} = 150 \text{ mA}$, $P_{out} = 1000 \text{ W Peak}$

f MHz	Z_{source} Ω	Z_{load} Ω
1090	$2.98 + j3.68$	$1.51 + j2.02$

Z_{source} = Test circuit impedance as measured from gate to gate, balanced configuration.

Z_{load} = Test circuit impedance as measured from drain to drain, balanced configuration.

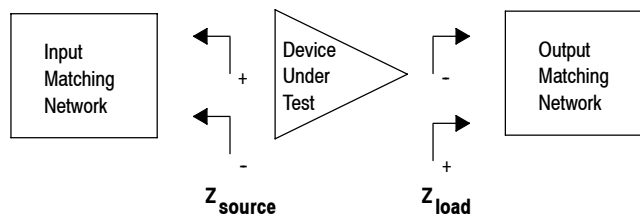
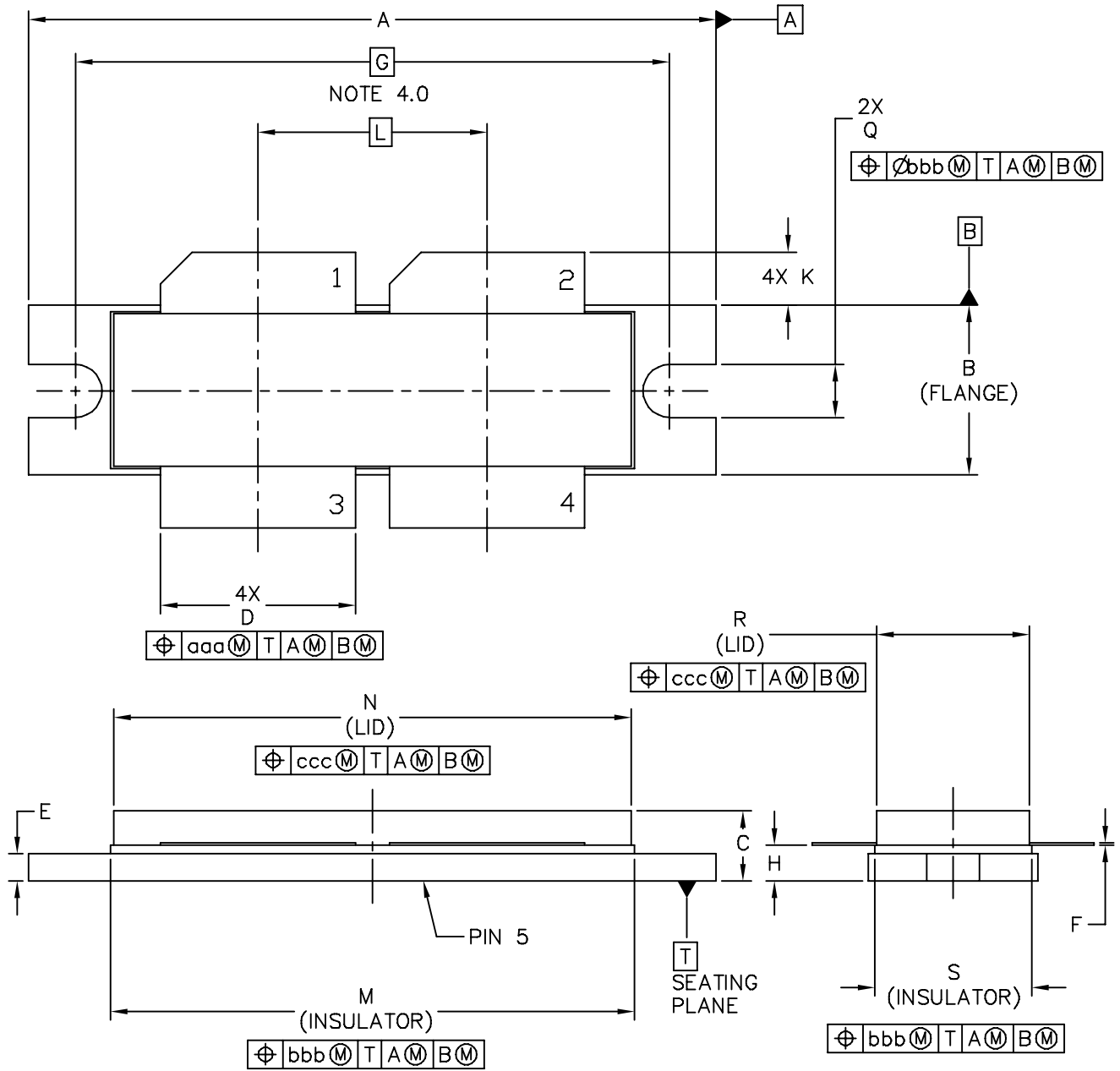

Figure 19. Series Equivalent Source and Load Impedance — 1090 MHz

PACKAGE DIMENSIONS



© FREESCALE SEMICONDUCTOR, INC. ALL RIGHTS RESERVED.		MECHANICAL OUTLINE		PRINT VERSION NOT TO SCALE	
TITLE: NI-1230		DOCUMENT NO: 98ASB16977C		REV: E	
		CASE NUMBER: 375D-05		31 MAR 2005	
		STANDARD: NON-JEDEC			

NOTES:

- 1.0 INTERPRET DIMENSIONS AND TOLERANCES PER ASME Y14.5M-1994.
- 2.0 CONTROLLING DIMENSION: INCH
- 3.0 DIMENSION H IS MEASURED .030 (0.762) AWAY FROM PACKAGE BODY.
- 4.0 RECOMMENDED BOLT CENTER DIMENSION OF 1.52 (38.61) BASED ON M3 SCREW.

STYLE 1:

- PIN 1 - DRAIN
- 2 - DRAIN
- 3 - GATE
- 4 - GATE
- 5 - SOURCE

DIM	INCH		MILLIMETER		DIM	INCH		MILLIMETER	
	MIN	MAX	MIN	MAX		MIN	MAX	MIN	MAX
A	1.615	1.625	41.02	41.28	N	1.218	1.242	30.94	31.55
B	.395	.405	10.03	10.29	Q	.120	.130	3.05	3.3
C	.150	.200	3.81	5.08	R	.355	.365	9.01	9.27
D	.455	.465	11.56	11.81	S	.365	.375	9.27	9.53
E	.062	.066	1.57	1.68					
F	.004	.007	0.1	0.18					
G	1.400 BSC		35.56 BSC		aaa	.013		0.33	
H	.082	.090	2.08	2.29	bbb	.010		0.25	
K	.117	.137	2.97	3.48	ccc	.020		0.51	
L	.540 BSC		13.72 BSC						
M	1.219	1.241	30.96	31.52					

© FREESCALE SEMICONDUCTOR, INC. ALL RIGHTS RESERVED.		MECHANICAL OUTLINE		PRINT VERSION NOT TO SCALE	
TITLE: NI-1230		DOCUMENT NO: 98ASB16977C		REV: E	
		CASE NUMBER: 375D-05		31 MAR 2005	
		STANDARD: NON-JEDEC			

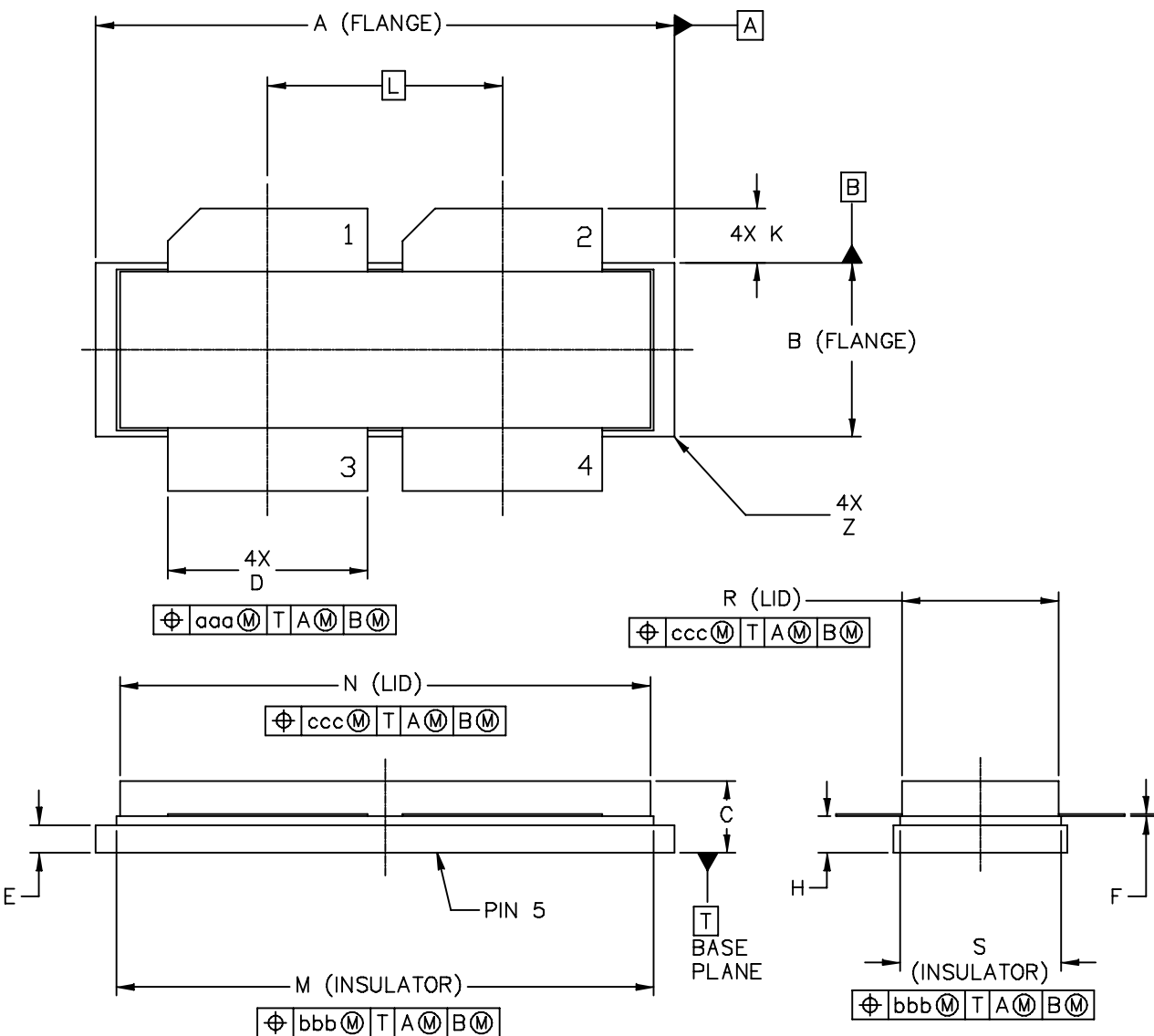

© FREESCALE SEMICONDUCTOR, INC. ALL RIGHTS RESERVED.		MECHANICAL OUTLINE		PRINT VERSION NOT TO SCALE	
TITLE: NI-1230S		DOCUMENT NO: 98ARB18247C		REV: F	
		CASE NUMBER: 375E-04		05 AUG 2005	
STANDARD: NON-JEDEC					

NOTES:

1. INTERPRET DIMENSIONS AND TOLERANCES PER ASME Y14.5M-1994.
2. CONTROLLING DIMENSION: INCH
3. DIMENSION H IS MEASURED .030 AWAY FROM PACKAGE BODY

STYLE 1:

- PIN 1 - DRAIN
- 2 - DRAIN
- 3 - GATE
- 4 - GATE
- 5 - SOURCE

DIM	INCHES		MILLIMETERS		DIM	INCHES		MILLIMETERS	
	MIN	MAX	MIN	MAX		MIN	MAX	MIN	MAX
A	1.265	1.275	32.13	32.38	R	.355	.365	9.01	9.27
B	.395	.405	10.03	10.29	S	.365	.375	9.27	9.53
C	.150	.200	3.81	5.08	Z	---	.040	---	1.02
D	.455	.465	11.56	11.81					
E	.062	.066	1.57	1.68	aaa	.013		0.33	
F	.004	.007	0.1	0.18	bbb	.010		0.25	
H	.082	.090	2.08	2.29	ccc	.020		0.51	
K	.117	.137	2.97	3.48					
L	.540 BSC		13.72 BSC						
M	1.219	1.241	30.96	31.52					
N	1.218	1.242	30.94	31.55					
© FREESCALE SEMICONDUCTOR, INC. ALL RIGHTS RESERVED.			MECHANICAL OUTLINE			PRINT VERSION NOT TO SCALE			
TITLE: NI-1230S					DOCUMENT NO: 98ARB18247C			REV: F	
					CASE NUMBER: 375E-04			05 AUG 2005	
					STANDARD: NON-JEDEC				

PRODUCT DOCUMENTATION AND SOFTWARE

Refer to the following documents to aid your design process.

Application Notes

- AN1955: Thermal Measurement Methodology of RF Power Amplifiers

Engineering Bulletins

- EB212: Using Data Sheet Impedances for RF LDMOS Devices

Software

- Electromigration MTTF Calculator

For Software, do a Part Number search at <http://www.freescale.com>, and select the “Part Number” link. Go to the Software & Tools tab on the part’s Product Summary page to download the respective tool.

REVISION HISTORY

The following table summarizes revisions to this document.

Revision	Date	Description
0	June 2009	<ul style="list-style-type: none"> • Initial Release of Data Sheet
1	June 2009	<ul style="list-style-type: none"> • Added Pulsed RF Performance tables for 785 MHz and 1090 MHz applications, p. 3 • Added Figs. 13 and 16, Test Circuit Component Layout - 785 MHz and 1090 MHz, and Tables 6 and 7, Test Circuit Component Designations and Values - 785 MHz and 1090 MHz, p. 9, 12 • Added Figs. 14 and 17, Pulsed Power Gain and Drain Efficiency versus Output Power - 785 MHz and 1090 MHz, p. 10, 13 • Added Figs. 15 and 18, Series Equivalent Source and Load Impedance - 785 MHz and 1090 MHz, p. 11, 14
2	Dec. 2009	<ul style="list-style-type: none"> • Added thermal data for 1030 MHz Mode-S application to Table 2, Thermal Characteristics, reporting of pulsed thermal data now shown using the $Z_{\theta JC}$ symbol, p. 2 • Added Typical Performances table for 1030 MHz Mode-S application, p. 3 • Added Fig. 12, MTTF versus Junction Temperature - 1030 MHz Mode-S, p. 7
3	Apr. 2010	<ul style="list-style-type: none"> • Operating Junction Temperature increased from 200°C to 225°C in Maximum Ratings table and related “Continuous use at maximum temperature will affect MTTF” footnote added, p. 1

How to Reach Us:

Home Page:

www.freescale.com

Web Support:

<http://www.freescale.com/support>

USA/Europe or Locations Not Listed:

Freescale Semiconductor, Inc.
Technical Information Center, EL516
2100 East Elliot Road
Tempe, Arizona 85284
1-800-521-6274 or +1-480-768-2130
www.freescale.com/support

Europe, Middle East, and Africa:

Freescale Halbleiter Deutschland GmbH
Technical Information Center
Schatzbogen 7
81829 Muenchen, Germany
+44 1296 380 456 (English)
+46 8 52200080 (English)
+49 89 92103 559 (German)
+33 1 69 35 48 48 (French)
www.freescale.com/support

Japan:

Freescale Semiconductor Japan Ltd.
Headquarters
ARCO Tower 15F
1-8-1, Shimo-Meguro, Meguro-ku,
Tokyo 153-0064
Japan
0120 191014 or +81 3 5437 9125
support.japan@freescale.com

Asia/Pacific:

Freescale Semiconductor China Ltd.
Exchange Building 23F
No. 118 Jianguo Road
Chaoyang District
Beijing 100022
China
+86 10 5879 8000
support.asia@freescale.com

For Literature Requests Only:

Freescale Semiconductor Literature Distribution Center
1-800-441-2447 or +1-303-675-2140
Fax: +1-303-675-2150
LDCForFreescaleSemiconductor@hibbertgroup.com

Information in this document is provided solely to enable system and software implementers to use Freescale Semiconductor products. There are no express or implied copyright licenses granted hereunder to design or fabricate any integrated circuits or integrated circuits based on the information in this document.

Freescale Semiconductor reserves the right to make changes without further notice to any products herein. Freescale Semiconductor makes no warranty, representation or guarantee regarding the suitability of its products for any particular purpose, nor does Freescale Semiconductor assume any liability arising out of the application or use of any product or circuit, and specifically disclaims any and all liability, including without limitation consequential or incidental damages. "Typical" parameters that may be provided in Freescale Semiconductor data sheets and/or specifications can and do vary in different applications and actual performance may vary over time. All operating parameters, including "Typicals", must be validated for each customer application by customer's technical experts. Freescale Semiconductor does not convey any license under its patent rights nor the rights of others. Freescale Semiconductor products are not designed, intended, or authorized for use as components in systems intended for surgical implant into the body, or other applications intended to support or sustain life, or for any other application in which the failure of the Freescale Semiconductor product could create a situation where personal injury or death may occur. Should Buyer purchase or use Freescale Semiconductor products for any such unintended or unauthorized application, Buyer shall indemnify and hold Freescale Semiconductor and its officers, employees, subsidiaries, affiliates, and distributors harmless against all claims, costs, damages, and expenses, and reasonable attorney fees arising out of, directly or indirectly, any claim of personal injury or death associated with such unintended or unauthorized use, even if such claim alleges that Freescale Semiconductor was negligent regarding the design or manufacture of the part.

Freescale™ and the Freescale logo are trademarks of Freescale Semiconductor, Inc. All other product or service names are the property of their respective owners.

© Freescale Semiconductor, Inc. 2009-2010. All rights reserved.

Looking for pricing, stock, or lifecycle information?

Click below to explore more details on WIN SOURCE:

 [View MRF6VP121KHR6 on WIN SOURCE](#)

 [NXP / Nexperia Information](#)

Optimize Your Supply Chain with WIN SOURCE Solutions

-  Global Sourcing Solution
-  Obsolete Management
-  Cost Control Management
-  Shortage Management
-  Alternative Solution
-  Excess Inventory Management