



## Features

- Fast Read Access Time - 90 ns
- Five-Volt-Only Reprogramming
- Sector Program Operation
  - Single Cycle Reprogram (Erase and Program)
  - 512 Sectors (128 bytes/sector)
  - Internal Address and Data Latches for 128 Bytes
- Internal Program Control and Timer
- Hardware and Software Data Protection
- Fast Sector Program Cycle Time - 10 ms
- DATA Polling for End of Program Detection
- Low Power Dissipation
  - 50 mA Active Current
  - 100  $\mu$ A CMOS Standby Current
- High Reliability CMOS Technology
  - 1000 Program Cycles per Sector
  - 10-Year Data Retention
- Single 5 V  $\pm$ 10% Supply
- CMOS and TTL Compatible Inputs and Outputs
- Full Military, Commercial, and Industrial Temperature Ranges

**512K (64K x 8)**  
**5-Volt Only**  
**CMOS Flash**  
**PEROM**

## Description

The AT29C512 is a five-volt-only in-system Flash Programmable and Erasable Read Only Memory (PEROM). Its 512K of memory is organized as 65,536 words by 8 bits. Manufactured with Atmel's advanced nonvolatile CMOS technology, the device offers access times to 90 ns with power dissipation of just 275 mW over the commercial temperature range. When the device is deselected, the CMOS standby current is less than 100  $\mu$ A.

*continued on next page*

## Pin Configurations

Pin Name	Function
A0 - A15	Addresses
$\overline{\text{CE}}$	Chip Enable
$\overline{\text{OE}}$	Output Enable
$\overline{\text{WE}}$	Write Enable
I/O0 - I/O7	Data Inputs/Outputs
NC	No Connect

DIP Top View

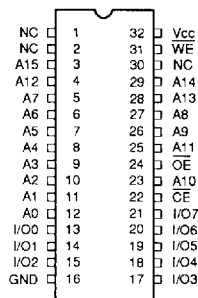

PLCC and LCC Top View

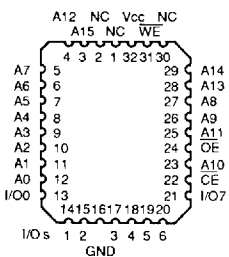

Note: PLCC package pin 30 is a DON'T CONNECT.

TSOP Top View  
Type 1

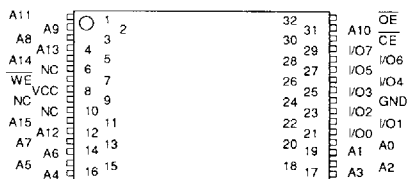

## Description (Continued)

To allow for simple in-system reprogrammability, the AT29C512 does not require high input voltages for programming. Five-volt-only commands determine the operation of the device. Reading data out of the device is similar to reading from an EPROM. Reprogramming the AT29C512 is performed on a sector basis; 128 bytes of data are loaded into the device and then simultaneously programmed.

During a reprogram cycle, the address locations and 128 bytes of data are internally latched, freeing the address and data bus for other operations. Following the initiation of a program cycle, the device will automatically erase the sector and then program the latched data using an internal control timer. The end of a program cycle can be detected by  $\overline{\text{DATA}}$  polling of I/O7. Once the end of a program cycle has been detected, a new access for a read or program can begin.

## Block Diagram

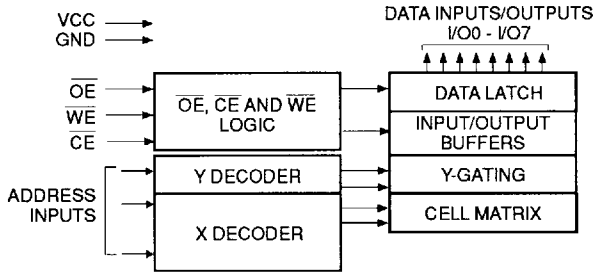

## Device Operation

**READ:** The AT29C512 is accessed like an EPROM. When  $\overline{\text{CE}}$  and  $\overline{\text{OE}}$  are low and  $\overline{\text{WE}}$  is high, the data stored at the memory location determined by the address pins is asserted on the outputs. The outputs are put in the high impedance state whenever  $\overline{\text{CE}}$  or  $\overline{\text{OE}}$  is high. This dual-line control gives designers flexibility in preventing bus contention.

**BYTE LOAD:** Byte loads are used to enter the 128 bytes of a sector to be programmed or the software codes for data protection. A byte load is performed by applying a low pulse on the  $\overline{\text{WE}}$  or  $\overline{\text{CE}}$  input with  $\overline{\text{CE}}$  or  $\overline{\text{WE}}$  low (respectively) and  $\overline{\text{OE}}$  high. The address is latched on the falling edge of  $\overline{\text{CE}}$  or  $\overline{\text{WE}}$ , whichever occurs last. The data is latched by the first rising edge of  $\overline{\text{CE}}$  or  $\overline{\text{WE}}$ .

**PROGRAM:** The device is reprogrammed on a sector basis. If a byte of data within a sector is to be changed, data for the entire sector must be loaded into the device. Any byte that is not loaded during the programming of its sector will be erased to read FFh. Once the bytes of a sector are loaded into the device, they are simultaneously programmed during the internal programming period. After the first data byte has been loaded into the device, successive bytes are entered in the same manner. Each new byte to be programmed must have its high to low transition on  $\overline{\text{WE}}$  (or  $\overline{\text{CE}}$ ) within 150  $\mu\text{s}$  of the low to high transition of  $\overline{\text{WE}}$  (or  $\overline{\text{CE}}$ ) of the preceding byte. If a high to low transition is not detected within 150  $\mu\text{s}$  of the last low to high transition, the load period will end and the internal programming period will start. A7 to A15 specify the sector address. The sector address must be valid during each high to low transition of  $\overline{\text{WE}}$  (or  $\overline{\text{CE}}$ ). A0 to A6 specify the byte address within the sector. The

bytes may be loaded in any order; sequential loading is not required.

**SOFTWARE DATA PROTECTION:** A software controlled data protection feature is available on the AT29C512. Once the software protection is enabled a software algorithm must be issued to the device before a program may be performed. The software protection feature may be enabled or disabled by the user; when shipped from Atmel, the software data protection feature is disabled. To enable the software data protection, a series of three program commands to specific addresses with specific data must be performed. After the software data protection is enabled the same three program commands must begin each program cycle in order for the programs to occur. All software program commands must obey the sector program timing specifications. Once set, the software data protection feature remains active unless its disable command is issued. Power transitions will not reset the software data protection feature, however the software feature will guard against inadvertent program cycles during power transitions.

Once set, software data protection will remain active unless the disable command sequence is issued.

After setting SDP, any attempt to write to the device without the three-byte command sequence will start the internal write timers. No data will be written to the device; however, for the duration of  $t_{\text{wrc}}$ , a read operation will effectively be a polling operation.

After the software data protection's three-byte command code is given, a byte load is performed by applying a low pulse on the  $\overline{\text{WE}}$  or  $\overline{\text{CE}}$  input with  $\overline{\text{CE}}$  or  $\overline{\text{WE}}$  low (respectively) and  $\overline{\text{OE}}$  high.

*continued on next page*

## Device Operation (Continued)

The address is latched on the falling edge of  $\overline{CE}$  or  $\overline{WE}$ , whichever occurs last. The data is latched by the first rising edge of  $\overline{CE}$  or  $\overline{WE}$ . The 128 bytes of data must be loaded into each sector by the same procedure as outlined in the program section under device operation.

**HARDWARE DATA PROTECTION:** Hardware features protect against inadvertent programs to the AT29C512 in the following ways: (a)  $V_{CC}$  sense— if  $V_{CC}$  is below 3.8 V (typical), the program function is inhibited. (b)  $V_{CC}$  power on delay— once  $V_{CC}$  has reached the  $V_{CC}$  sense level, the device will automatically time out 5 ms (typical) before programming. (c) Program inhibit— holding any one of  $\overline{OE}$  low,  $\overline{CE}$  high or  $\overline{WE}$  high inhibits program cycles. (d) Noise filter— pulses of less than 15 ns (typical) on the  $\overline{WE}$  or  $\overline{CE}$  inputs will not initiate a program cycle.

**PRODUCT IDENTIFICATION:** The product identification mode identifies the device and manufacturer as Atmel. It may be accessed by hardware or software operation. The hardware operation mode can be used by an external programmer to identify the correct programming algorithm for the Atmel product. In addition, users may wish to use the software product identification mode to identify the part (i.e. using the device code), and have the system software use the appropriate sector size for program operations. In this manner, the user can have a common

board design for 256K to 4-megabit densities and, with each density's sector size in a memory map, have the system software apply the appropriate sector size.

For details, see Operating Modes (for hardware operation) or Software Product Identification. The manufacturer and device code is the same for both modes.

**DATA POLLING:** The AT29C512 features  $\overline{DATA}$  polling to indicate the end of a program cycle. During a program cycle an attempted read of the last byte loaded will result in the complement of the loaded data on I/O7. Once the program cycle has been completed, true data is valid on all outputs and the next cycle may begin.  $\overline{DATA}$  polling may begin at any time during the program cycle.

**TOGGLE BIT:** In addition to  $\overline{DATA}$  polling the AT29C512 provides another method for determining the end of a program or erase cycle. During a program or erase operation, successive attempts to read data from the device will result in I/O6 toggling between one and zero. Once the program cycle has completed, I/O6 will stop toggling and valid data will be read. Examining the toggle bit may begin at any time during a program cycle.

**OPTIONAL CHIP ERASE MODES:** The entire device may be erased by either using a six-byte software code or high voltage. For details, please contact Atmel.

## Absolute Maximum Ratings\*

Temperature Under Bias.....	-55°C to +125°C
Storage Temperature.....	-65°C to +150°C
All Input Voltages (including N.C. Pins) with Respect to Ground .....	-0.6 V to +6.25 V
All Output Voltages with Respect to Ground .....	-0.6 V to $V_{CC} + 0.6$ V
Voltage on $\overline{OE}$ with Respect to Ground .....	-0.6 V to +13.5 V

\*NOTICE: Stresses beyond those listed under "Absolute Maximum Ratings" may cause permanent damage to the device. This is a stress rating only and functional operation of the device at these or any other conditions beyond those indicated in the operational sections of this specification is not implied. Exposure to absolute maximum rating conditions for extended periods may affect device reliability.

## Pin Capacitance (f = 1 MHz, T = 25°C) <sup>(1)</sup>

	Typ	Max	Units	Conditions
C <sub>IN</sub>	4	6	pF	V <sub>IN</sub> = 0 V
C <sub>OUT</sub>	8	12	pF	V <sub>OUT</sub> = 0 V

Notes: 1. This parameter is characterized and is not 100% tested





## D.C. and A.C. Operating Range

		AT29C512-90	AT29C512-12	AT29C512-15	AT29C512-20
Operating Temperature (Case)	Com.	0°C - 70°C	0°C - 70°C	0°C - 70°C	0°C - 70°C
	Ind.	-40°C - 85°C	-40°C - 85°C	-40°C - 85°C	-40°C - 85°C
	Mil.		-55°C - 125°C	-55°C - 125°C	-55°C - 125°C
V <sub>CC</sub> Power Supply		5 V ± 10%	5 V ± 10%	5 V ± 10%	5 V ± 10%

## Operating Modes

Mode	$\overline{CE}$	$\overline{OE}$	$\overline{WE}$	Ai	I/O
Read	V <sub>IL</sub>	V <sub>IL</sub>	V <sub>IH</sub>	Ai	DOUT
Program <sup>(2)</sup>	V <sub>IL</sub>	V <sub>IH</sub>	V <sub>IL</sub>	Ai	DIN
5V Chip Erase	V <sub>IL</sub>	V <sub>IH</sub>	V <sub>IL</sub>	Ai	
Standby/Write Inhibit	V <sub>IH</sub>	X <sup>(1)</sup>	X	X	High Z
Program Inhibit	X	X	V <sub>IH</sub>		
Program Inhibit	X	V <sub>IL</sub>	X		
Output Disable	X	V <sub>IH</sub>	X		High Z
Product Identification					
Hardware	V <sub>IL</sub>	V <sub>IL</sub>	V <sub>IH</sub>	A1-A15 = V <sub>IL</sub> , A9 = V <sub>IH</sub> , <sup>(3)</sup> A0 = V <sub>IL</sub>	Manufacturer Code <sup>(4)</sup>
				A1-A15 = V <sub>IL</sub> , A9 = V <sub>IH</sub> , <sup>(3)</sup> A0 = V <sub>IH</sub>	Device Code <sup>(4)</sup>
Software <sup>(5)</sup>				A0 = V <sub>IL</sub>	Manufacturer Code <sup>(4)</sup>
				A0 = V <sub>IH</sub>	Device Code <sup>(4)</sup>

Notes: 1. X can be V<sub>IL</sub> or V<sub>IH</sub>.

2. Refer to A.C. Programming Waveforms.

3. V<sub>IH</sub> = 12.0 V ± 0.5 V

4. Manufacturer Code: 1F, Device Code: 5D

5. See details under Software Product Identification Entry/Exit.

## D.C. Characteristics

Symbol	Parameter	Condition	Min	Max	Units
I <sub>LI</sub>	Input Load Current	V <sub>IN</sub> = 0 V to V <sub>CC</sub>		10	μA
I <sub>LO</sub>	Output Leakage Current	V <sub>I/O</sub> = 0 V to V <sub>CC</sub>		10	μA
I <sub>SB1</sub>	V <sub>CC</sub> Standby Current CMOS	$\overline{CE} = V_{CC} - 0.3 V$ to V <sub>CC</sub>	Com.	100	μA
			Ind., Mil.	300	μA
I <sub>SB2</sub>	V <sub>CC</sub> Standby Current TTL	$\overline{CE} = 2.0 V$ to V <sub>CC</sub>		3	mA
I <sub>CC</sub>	V <sub>CC</sub> Active Current	f = 5 MHz; I <sub>OUT</sub> = 0 mA		50	mA
V <sub>IL</sub>	Input Low Voltage			0.8	V
V <sub>IH</sub>	Input High Voltage		2.0		V
V <sub>OL</sub>	Output Low Voltage	I <sub>OL</sub> = 2.1 mA		.45	V
V <sub>OH1</sub>	Output High Voltage	I <sub>OH</sub> = -400 μA	2.4		V
V <sub>OH2</sub>	Output High Voltage CMOS	I <sub>OH</sub> = -100 μA; V <sub>CC</sub> = 4.5 V	4.2		V

A.C. Read Characteristics

Symbol	Parameter	AT29C512-90		AT29C512-12		AT29C512-15		AT29C512-20		Units
		Min	Max	Min	Max	Min	Max	Min	Max	
$t_{ACC}$	Address to Output Delay		90		120		150		200	ns
$t_{CE}^{(1)}$	$\overline{CE}$ to Output Delay		90		120		150		200	ns
$t_{OE}^{(2)}$	$\overline{OE}$ to Output Delay	0	40	0	50	0	70	0	80	ns
$t_{DF}^{(3,4)}$	$\overline{CE}$ or $\overline{OE}$ to Output Float	0	25	0	30	0	40	0	50	ns
$t_{OH}$	Output Hold from $\overline{OE}$ , $\overline{CE}$ or Address, whichever occurred first	0		0		0		0		ns

A.C. Read Waveforms

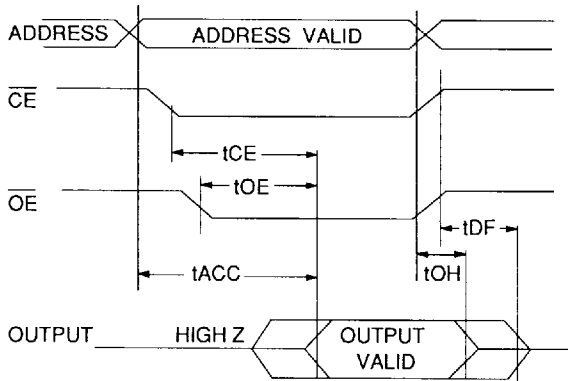

- Notes:
- $\overline{CE}$  may be delayed up to  $t_{ACC} - t_{CE}$  after the address transition without impact on  $t_{ACC}$ .
  - $\overline{OE}$  may be delayed up to  $t_{CE} - t_{OE}$  after the falling edge of  $\overline{CE}$  without impact on  $t_{CE}$  or by  $t_{ACC} - t_{OE}$  after an address change without impact on  $t_{ACC}$ .
  - $t_{DF}$  is specified from  $\overline{OE}$  or  $\overline{CE}$  whichever occurs first ( $C_L = 5$  pF).
  - This parameter is characterized and is not 100% tested.

Input Test Waveforms and Measurement Level

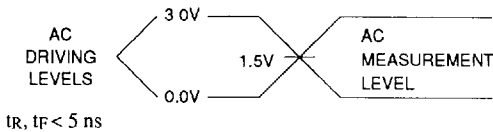

Output Test Load

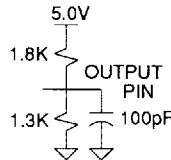

## A.C. Byte Load Characteristics

Symbol	Parameter	Min	Max	Units
tAS, tOES	Address, $\overline{OE}$ Set-up Time	0		ns
tAH	Address Hold Time	50		ns
tCS	Chip Select Set-up Time	0		ns
tCH	Chip Select Hold Time	0		ns
tWP	Write Pulse Width ( $\overline{WE}$ or $\overline{CE}$ )	90		ns
tDS	Data Set-up Time	50		ns
tDH, tOEH	Data, $\overline{OE}$ Hold Time	0		ns
tWPH	Write Pulse Width High	100		ns

### A.C. Byte Load Waveforms- $\overline{WE}$ Controlled

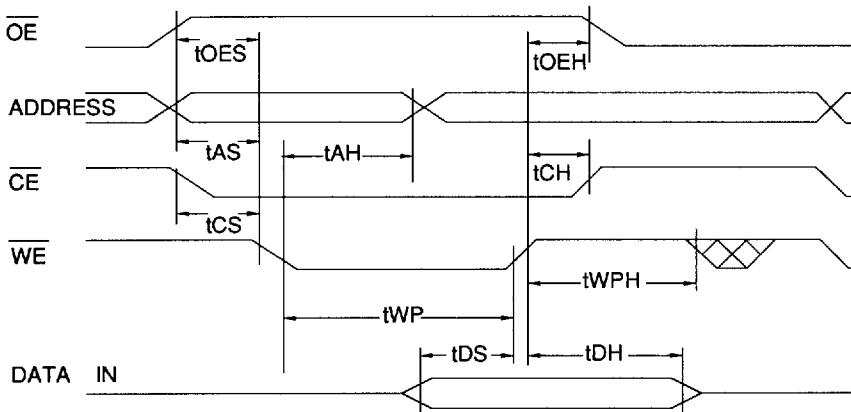

### A.C. Byte Load Waveforms- $\overline{CE}$ Controlled

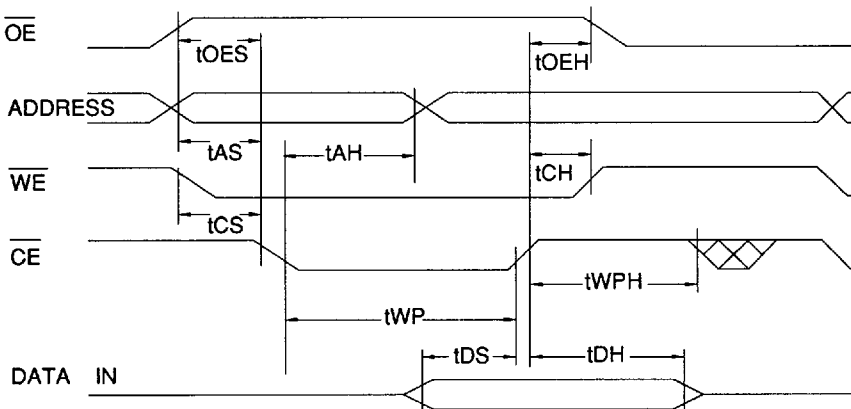

Program Cycle Characteristics

Symbol	Parameter	Min	Max	Units
t <sub>WC</sub>	Write Cycle Time		10	ms
t <sub>AS</sub>	Address Set-up Time	0		ns
t <sub>AH</sub>	Address Hold Time	50		ns
t <sub>DS</sub>	Data Set-up Time	50		ns
t <sub>DH</sub>	Data Hold Time	0		ns
t <sub>WP</sub>	Write Pulse Width	90		ns
t <sub>BLC</sub>	Byte Load Cycle Time		150	μs
t <sub>WPH</sub>	Write Pulse Width High	100		ns

Program Cycle Waveforms

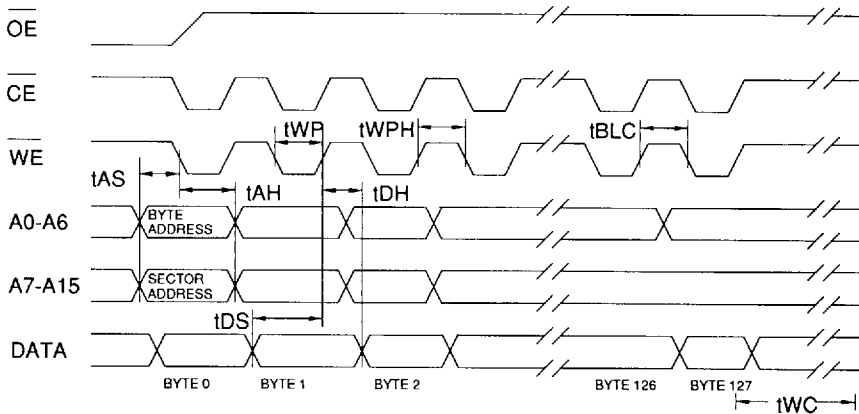

Notes: A7 through A15 must specify the sector address during each high to low transition of WE (or CE).  
 OE must be high when WE and CE are both low.  
 All bytes that are not loaded within the sector being programmed will be erased to FF.



## Software Data Protection Enable Algorithm <sup>(1)</sup>

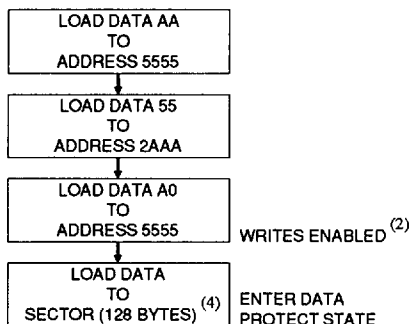

## Software Data Protection Disable Algorithm <sup>(1)</sup>

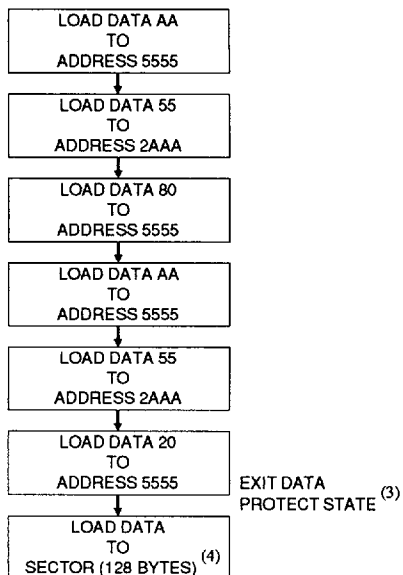

Notes for software program code:

1. Data Format: I/O7 - I/O0 (Hex);  
Address Format: A14 - A0 (Hex).
2. Data Protect state will be activated at end of program cycle.
3. Data Protect state will be deactivated at end of program period.
4. 128 bytes of data MUST BE loaded.

## Software Protected Program Cycle Waveform

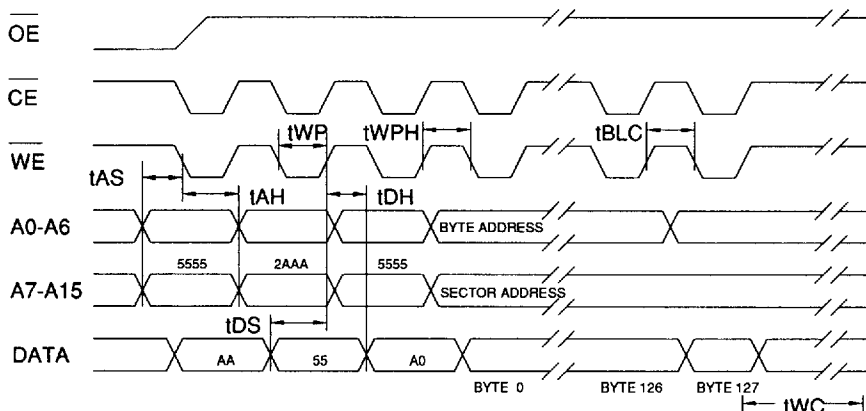

- Notes:
- A7 through A15 must specify the sector address during each high to low transition of WE (or CE) after the software code has been entered.
  - OE must be high when WE and CE are both low.
  - All bytes that are not loaded within the sector being programmed will be erased to FF.

**Data Polling Characteristics<sup>(1)</sup>**

Symbol	Parameter	Min	Typ	Max	Units
t <sub>DH</sub>	Data Hold Time	10			ns
t <sub>OEH</sub>	$\overline{OE}$ Hold Time	10			ns
t <sub>OE</sub>	$\overline{OE}$ to Output Delay <sup>(2)</sup>			100	ns
t <sub>WR</sub>	Write Recovery Time	0			ns

Notes: 1. These parameters are characterized and not 100% tested.  
 2. See t<sub>OE</sub> spec in A.C. Read Characteristics.

**Data Polling Waveforms**

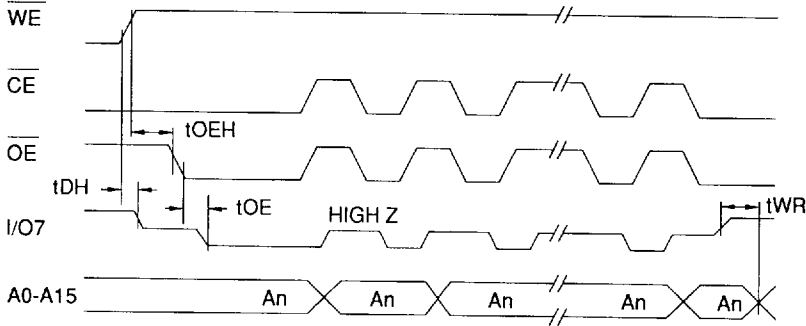

**Toggle Bit Characteristics<sup>(1)</sup>**

Symbol	Parameter	Min	Typ	Max	Units
t <sub>DH</sub>	Data Hold Time	10			ns
t <sub>OEH</sub>	$\overline{OE}$ Hold Time	10			ns
t <sub>OE</sub>	$\overline{OE}$ to Output Delay <sup>(2)</sup>				ns
t <sub>OEHP</sub>	$\overline{OE}$ High Pulse	150			ns
t <sub>WR</sub>	Write Recovery Time	0			ns

Notes: 1. These parameters are characterized and not 100% tested.  
 2. See t<sub>OE</sub> spec in A.C. Read Characteristics.

**Toggle Bit Waveforms**

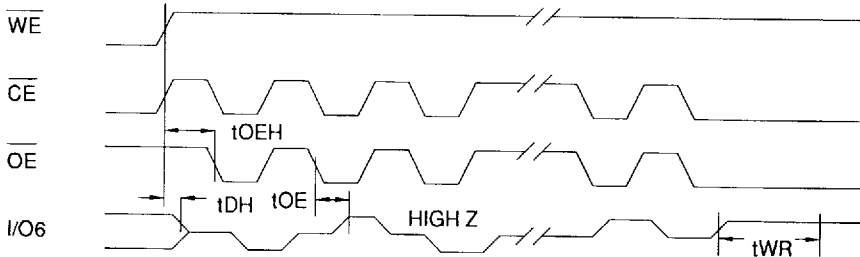

Notes:  
 1. Toggling either  $\overline{OE}$  or  $\overline{CE}$  or both  $\overline{OE}$  and  $\overline{CE}$  will operate toggle bit.  
 2. Beginning and ending state of I/O6 will vary.  
 3. Any address location may be used but the address should not vary

## Software Product Identification Entry <sup>(1)</sup>

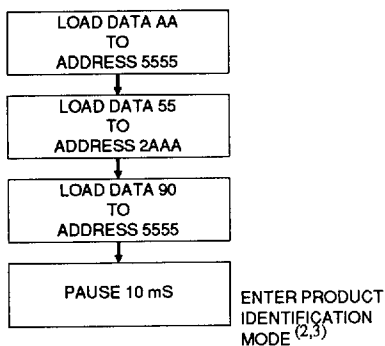

## Software Product Identification Exit <sup>(1)</sup>

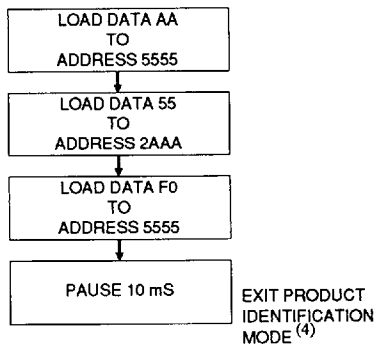

Notes for software product identification:

1. Data Format: I/O7 - I/O0 (Hex);  
Address Format: A14 - A0 (Hex).
2. A1 - A15 = V<sub>IL</sub>.  
Manufacture Code is read for A0 = V<sub>IL</sub>;  
Device Code is read for A0 = V<sub>IH</sub>.
3. The device does not remain in identification mode if powered down.
4. The device returns to standard operation mode.
5. Manufacturer Code: 1F  
Device Code: 5D

NORMALIZED SUPPLY CURRENT vs. TEMPERATURE

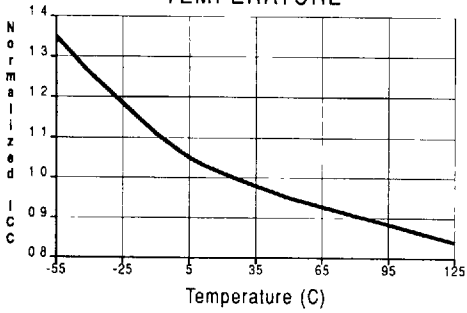

NORMALIZED SUPPLY CURRENT vs. SUPPLY VOLTAGE

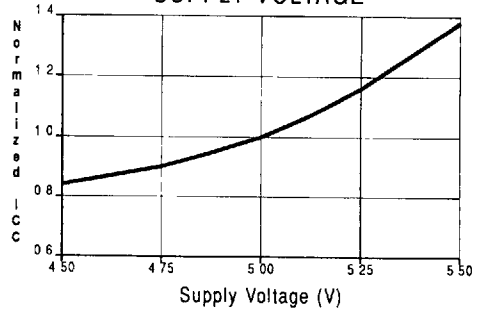

NORMALIZED SUPPLY CURRENT vs. ADDRESS FREQUENCY

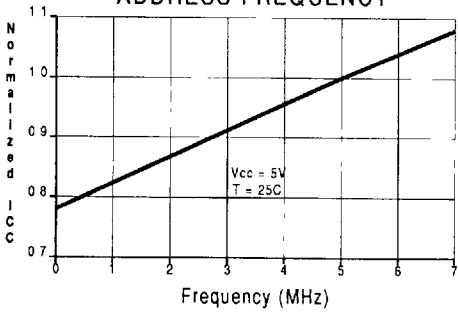



## Ordering Information

tACC (ns)	Icc (mA)		Ordering Code	Package	Operation Range
	Active	Standby			
90	50	0.1	AT29C512-90DC AT29C512-90JC AT29C512-90PC	32D6 32J 32P6	Commercial (0° to 70°C)
90	50	0.3	AT29C512-90DI AT29C512-90JI AT29C512-90PI	32D6 32J 32P6	Industrial (-40° to 85°C)
120	50	0.1	AT29C512-12DC AT29C512-12JC AT29C512-12PC AT29C512-12TC	32D6 32J 32P6 32T	Commercial (0° to 70°C)
120	50	0.3	AT29C512-12DI AT29C512-12JI AT29C512-12PI	32D6 32J 32P6	Industrial (-40° to 85°C)
			AT29C512-12DM	32D6	Military (-55°C to 125°C)
			AT29C512-12DM/883	32D6	Military/883C Class B, Fully Compliant (-55°C to 125°C)
150	50	0.1	AT29C512-15DC AT29C512-15JC AT29C512-15PC AT29C512-15TC	32D6 32J 32P6 32T	Commercial (0° to 70°C)
150	50	0.3	AT29C512-15DI AT29C512-15JI AT29C512-15PI	32D6 32J 32P6	Industrial (-40° to 85°C)
			AT29C512-15DM	32D6	Military (-55°C to 125°C)
			AT29C512-15DM/883	32D6	Military/883C Class B, Fully Compliant (-55°C to 125°C)
200	50	0.1	AT29C512-20DC AT29C512-20JC AT29C512-20PC	32D6 32J 32P6	Commercial (0° to 70°C)
200	50	0.3	AT29C512-20DI AT29C512-20JI AT29C512-20PI	32D6 32J 32P6	Industrial (-40° to 85°C)
			AT29C512-20DM	32D6	Military (-55°C to 125°C)
			AT29C512-20DM/883	32D6	Military/883C Class B, Fully Compliant (-55°C to 125°C)

1074177 0006932 839 ■

Ordering Information

Package Type	
32D6	32 Lead, 0.600" Wide, Non-Windowed, Ceramic Dual Inline Package (Cerdip)
32J	32 Lead, Plastic J-Leaded Chip Carrier (PLCC)
32P6	32 Lead, 0.600" Wide, Plastic Dual Inline Package (PDIP)
32T	32 Lead, Thin Small Outline Package (TSOP)

## Packaging Information

**28D6**, 28 Lead, 0.600" Wide, Non-Windowed,  
Ceramic Dual Inline Package (Cerdip)  
Dimensions in Inches and (Millimeters)  
MIL-STD-1835 D-10 CONFIG 1

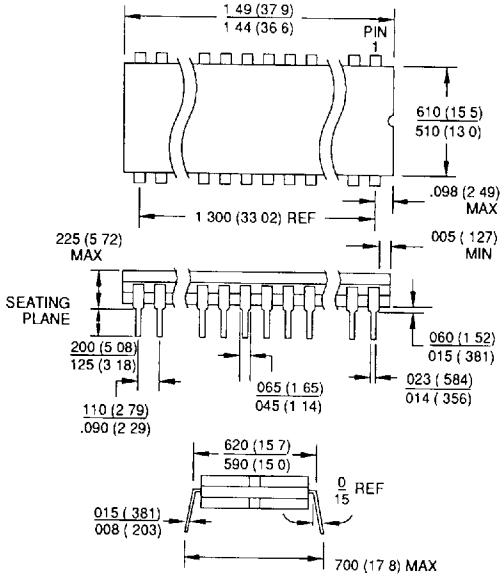

**32D6**, 32 Lead, 0.600" Wide, Non-Windowed,  
Ceramic Dual Inline Package (Cerdip)  
Dimensions in Inches and (Millimeters)  
MIL-STD-1835 CONFIG A

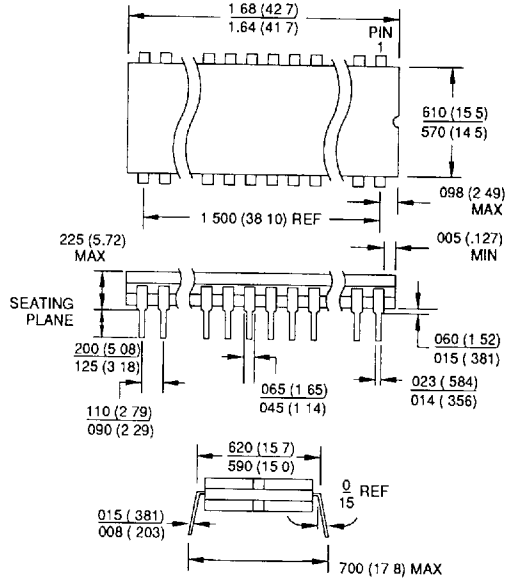

**32F**, 32 Lead, Non-Windowed,  
Ceramic Bottom Brazed Flat Package (Flatpack)  
Dimensions in Inches and (Millimeters)  
MIL-STD-1835 F-18 CONFIG B  
JEDEC OUTLINE MO-115

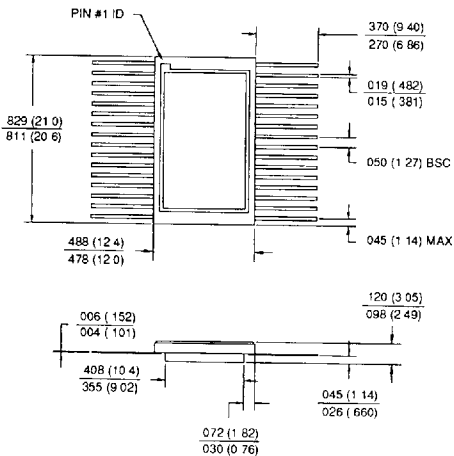

**32J**, 32 Lead, Plastic J-Leaded Chip Carrier (PLCC)  
Dimensions in Inches and (Millimeters)  
JEDEC OUTLINE MO-52 AC

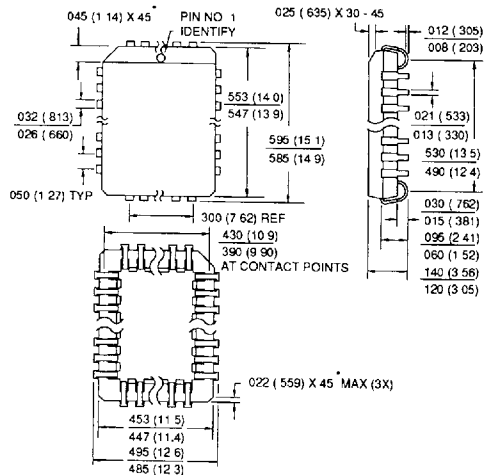

## Packaging Information

**44J, 44 Lead, Plastic J-Leaded Chip Carrier (PLCC)**  
 Dimensions in Inches and (Millimeters)  
 JEDEC OUTLINE MO-47 AC

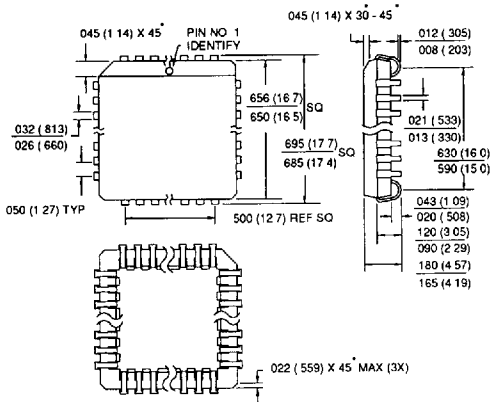

**32L, 32 Pad, Non-Windowed, Ceramic Leadless Chip Carrier (LCC)**  
 Dimensions in Inches and (Millimeters)\*

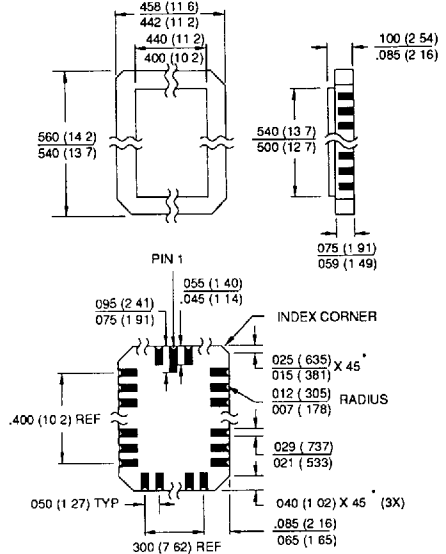

\*Ceramic lid standard unless specified

**44L, 44 Pad, Non-Windowed, Ceramic Leadless Chip Carrier (LCC)**  
 Dimensions in Inches and (Millimeters)\*

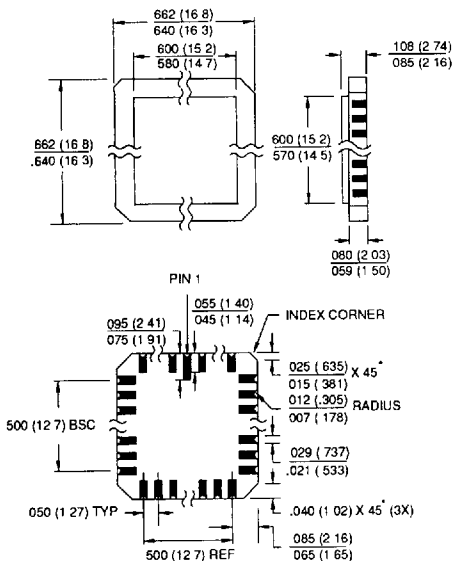

\*Ceramic lid standard unless specified.

**28P6, 28 Lead, 0.600" Wide, Plastic Dual In-line Package (PDIP)**  
 Dimensions in Inches and (Millimeters)

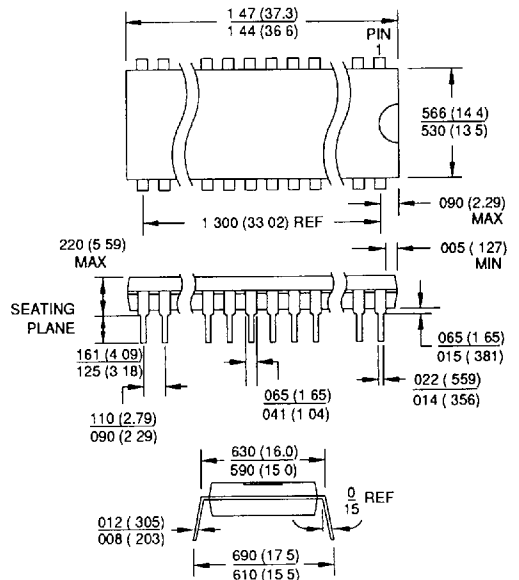

## Packaging Information

**32P6, 32 Lead, 0.600" Wide,  
Plastic Dual Inline Package (PDIP)  
Dimensions in Inches and (Millimeters)**

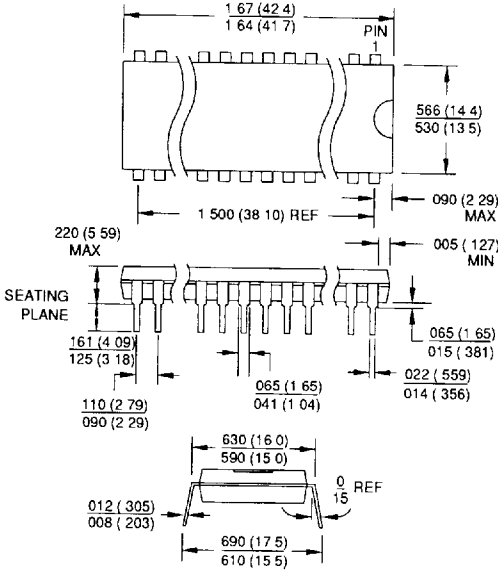

**28T, 28 Lead, Plastic Thin Small Outline Package (TSOP)  
Dimensions in Millimeters and (Inches)\***

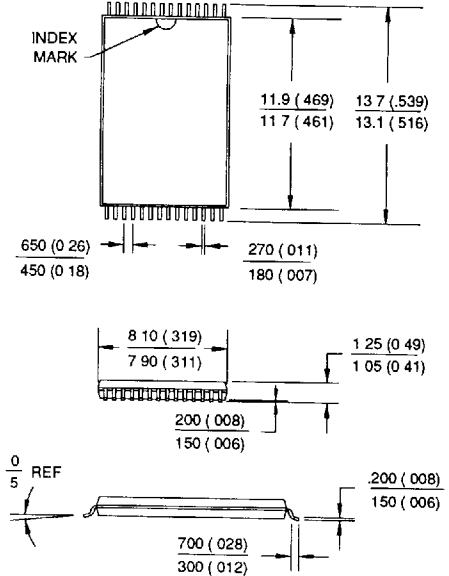

\*Controlling dimension, millimeters

**32T, 32 Lead, Plastic Thin Small Outline Package (TSOP)  
Dimensions in Millimeters and (Inches)\***

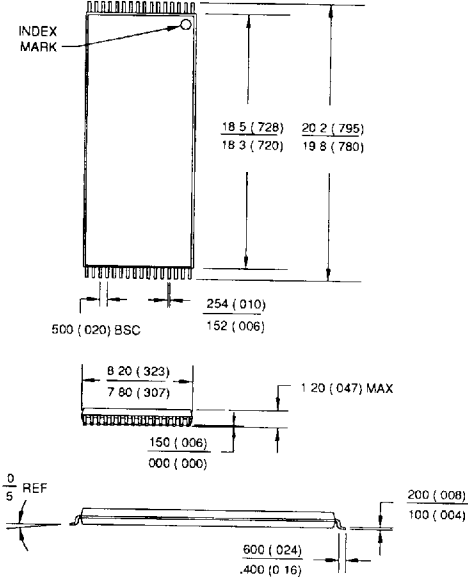

\*Controlling dimension millimeters

**40T, 40 Lead, Plastic Thin Small Outline Package (TSOP)  
Dimensions in Millimeters and (Inches)\***

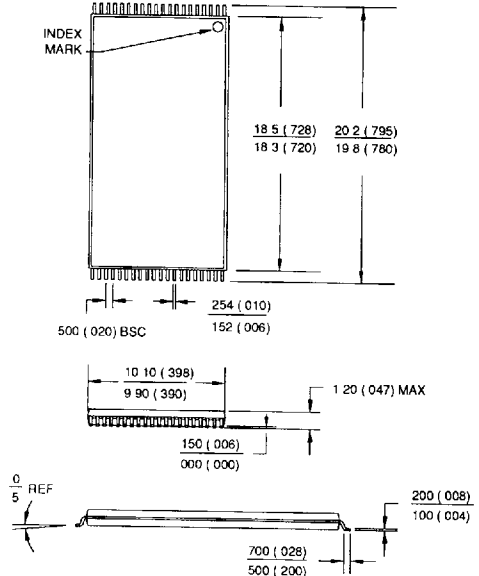

\*Controlling dimension millimeters

## Packaging Information

**48T, 48 Lead, Plastic Thin Small Outline Package (TSOP)**

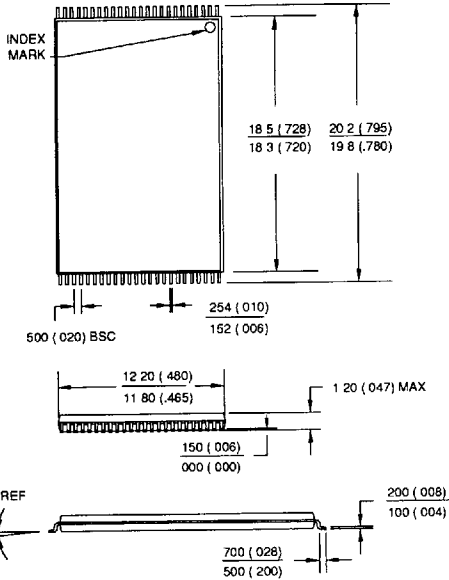

Dimensions in Millimeters and (Inches)\*







\*Controlling dimension: millimeters

## Looking for pricing, stock, or lifecycle information?

Click below to explore more details on WIN SOURCE:

-  [View AT29C512-20PC on WIN SOURCE](#)
-  [Microchip Technology Information](#)

## Optimize Your Supply Chain with WIN SOURCE Solutions

-  Global Sourcing Solution
-  Obsolete Management
-  Cost Control Management
-  Shortage Management
-  Alternative Solution
-  Excess Inventory Management