



**THE DATASHEET OF
CY7B9950AXC**



2.5/3.3 V, 200 MHz High-Speed Multi-Phase PLL Clock Buffer

Features

- 2.5 V or 3.3 V operation
- Split output bank power supplies
- Output frequency range: 6 MHz to 200 MHz
- 50 ps typical matched-pair output-output skew
- 50 ps typical cycle-cycle jitter
- 49.5 / 50.5% typical output duty cycle
- Selectable output drive strength
- Selectable positive or negative edge synchronization
- Eight LVTTTL outputs driving 50Ω terminated lines
- LVCMOS / LVTTTL overvoltage tolerant reference input
- Phase adjustments in 625 / 1250 ps steps up to ±7.5 ns
- 2×, 4× multiply and (1/2)×, (1/4)× divide ratios
- Spread spectrum compatible
- Industrial temperature range: -40 °C to +85 °C
- 32-pin TQFP package

Functional Description

The CY7B9950 RoboClock® is a low voltage, low power, eight-output, 200 MHz clock driver. It features output phase programmability which is necessary to optimize the clock tree design of high performance computer and communication systems.

The user can program the phase of the output banks through nF[0:1] pins. The adjustable phase feature enables the user to skew the outputs to lead or lag the reference clock. Any one of the outputs can be connected to the feedback input to achieve different reference frequency multiplications, divide ratios, and zero input-output delay.

The device also features split output bank power supplies, which enable the user to run two banks (1Qn and 2Qn) at a power supply level different from that of the other two banks (3Qn and 4Qn). Additionally, the three-level PE/HD pin controls the synchronization of the output signals to either the rising or falling edge of the reference clock and selects the drive strength of the output buffers. The high drive option (PE/HD = MID) increases the output current from ± 12 mA to ± 24 mA(3.3 V).

For a complete list of related documentation, [click here](#).

Logic Block Diagram

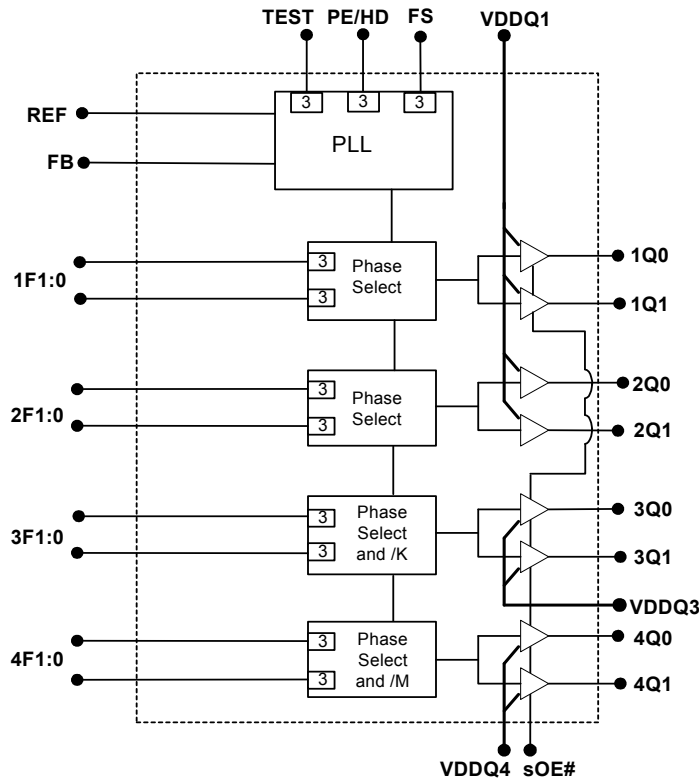

Contents

Pinouts	3	Ordering Information	13
Pin Definitions	4	Ordering Code Definitions	13
Device Configuration	5	Package Diagram	14
Governing Agencies	5	Acronyms	15
Absolute Maximum Conditions	6	Document Conventions	15
Operating Conditions	6	Units of Measure	15
DC Electrical Specifications at 2.5 V	7	Document History Page	16
DC Electrical Specifications at 3.3 V	8	Sales, Solutions, and Legal Information	18
Thermal Resistance	9	Worldwide Sales and Design Support	18
AC Test Loads and Waveforms	9	Products	18
AC Input Specifications	10	PSoC@Solutions	18
Switching Characteristics	11	Cypress Developer Community	18
AC Timing Definitions	12	Technical Support	18

Pinouts

Figure 1. 32-pin TQFP pinout (Top View)

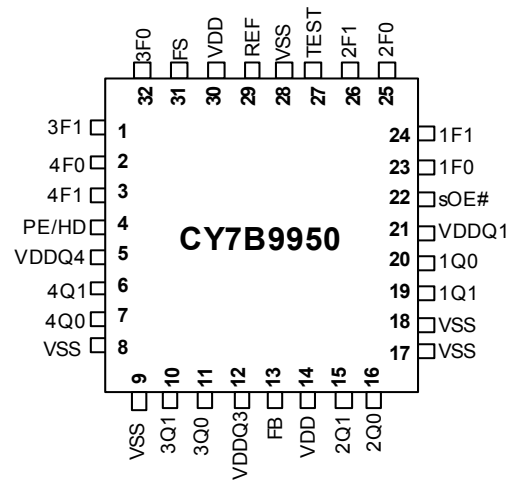

Pin Definitions

Pin	Name	I/O ^[1]	Type	Description
29	REF	I	LVTTL / LVCMOS	Reference clock input.
13	FB	I	LVTTL	Feedback input.
27	TEST	I	Three-level	When MID or HIGH, disables PLL ^[2] . REF goes to outputs of Bank 1 and Bank 2. REF also goes to outputs of Bank 3 and Bank 4 through output dividers K and M. Set LOW for normal operation.
22	sOE#	I, PD	Two-level	Synchronous output enable. When HIGH, it stops clock outputs (except 2Q0 and 2Q1) in a Low state (for PE = H or M) – 2Q0, and 2Q1 may be used as the feedback signal to maintain phase lock. When test is held at MID level and sOE# is HIGH, the nF[1:0] pins act as output disable controls for individual banks when nF[1:0] = LL. Set sOE# Low for normal operation.
4	PE/HD	I, PU	Three-level	Selects Positive or negative edge control and High or low output drive strength. When Low/High the outputs are synchronized with the negative/positive edge of the reference clock, respectively. When at MID level, the output drive strength is increased and the outputs synchronize with the positive edge of the reference clock (see Table 6 on page 5).
24, 23, 26, 25, 1, 32, 3, 2	nF[1:0]	I	Three-level	Select frequency and phase of the outputs (see Table 1 , Table 2 , Table 3 on page 5 , Table 4 on page 5 , and Table 5 on page 5).
31	FS	I	Three-level	Selects VCO operating frequency range (see Table 4 on page 5)
19, 20, 15, 16, 10, 11, 6, 7	nQ[1:0]	O	LVTTL	Four banks of two outputs (see Table 1 , Table 2 , and Table 3 on page 5)
21	V _{DDQ1} ^[3]	PWR	Power	Power supply for Bank 1 and Bank 2 output buffers (see Table 7 on page 5 for supply level constraints).
12	V _{DDQ3} ^[3]	PWR	Power	Power supply for Bank 3 output buffers (see Table 7 on page 5 for supply level constraints).
5	V _{DDQ4} ^[3]	PWR	Power	Power supply for Bank 4 output buffers (see Table 7 on page 5 for supply level constraints).
14, 30	V _{DD} ^[3]	PWR	Power	Power supply for internal circuitry (see Table 7 on page 5 for supply level constraints).
8, 9, 17, 18, 28	V _{SS}	PWR	Power	Ground

Notes

1. PD indicates an internal pull-down and PU indicates an internal pull-up. 3 indicates a three-level input buffer.
2. When TEST = MID and sOE# = HIGH, PLL remains active with nF[1:0] = LL functioning as an output disable control for individual output banks. Skew selections remain in effect unless nF[1:0] = LL.
3. A bypass capacitor (0.1μF) must be placed as close as possible to each positive power pin (< 0.2"). If these bypass capacitors are not close to the pins their high-frequency filtering characteristic are cancelled by the lead inductance of the traces.

Device Configuration

The outputs of the CY7B9950 can be configured to run at frequencies ranging from 6 to 200 MHz. Banks 3 and 4 output dividers are controlled by 3F[1:0] and 4F[1:0] as indicated in Table 1 and Table 2, respectively.

Table 1. Output Divider Settings — Bank 3

3F[1:0]	K — Bank3 output divider
LL	2
HH	4
Other ^[4]	1

Table 2. Output Divider Settings — Bank 4

4F[1:0]	M — Bank4 output divider
LL	2
Other ^[4]	1

The three-level FS control pin setting determines the nominal operating frequency range of the divide-by-one outputs of the device. The CY7B9950 PLL operating frequency range that corresponds to each FS level is given in Table 3 on page 5.

Table 3. Frequency Range Select

FS	PLL frequency range
L	24 to 50 MHz
M	48 to 100 MHz
H	96 to 200 MHz

The selectable output skew is in discrete increments of time units (t_U). The value of t_U is determined by the FS setting and the maximum nominal frequency. The equation used to determine the t_U value is: $t_U = 1 / (f_{NOM} \times MF)$, where MF is a multiplication factor, which is determined by the FS setting as indicated in Table 4.

Table 4. MF Calculation

FS	MF	f_{NOM} at which t_U is 1.0 ns (MHz)
L	32	31.25
M	16	62.5
H	8	125

Table 5. Output Skew Settings

nF[1:0]	Skew (1Q[0:1],2Q[0:1])	Skew (3Q[0:1])	Skew (4Q[0:1])
LL ^[5]	$-4t_U$	Divide by 2	Divide by 2
LM	$-3t_U$	$-6t_U$	$-6t_U$

Notes

- These states are used to program the phase of the respective banks (see Table 5 on page 5).
- LL disables outputs if TEST = MID and sOE# = HIGH.
- When 4Q[0:1] are set to run inverted (HH mode), sOE# disables these outputs HIGH when PE/HD = HIGH or MID and sOE# disables them LOW when PE/HD = LOW.
- Please refer to "DC Parameters" section for I_{QH}/I_{OL} specifications.
- $V_{DDQ1/3/4}$ must not be set at a level higher than that of V_{DD} . They can be set at different levels from each other, e.g., $V_{DD} = 3.3$ V, $V_{DDQ1} = 3.3$ V, $V_{DDQ3} = 2.5$ V and $V_{DDQ4} = 2.5$ V.

Table 5. Output Skew Settings(continued)

nF[1:0]	Skew (1Q[0:1],2Q[0:1])	Skew (3Q[0:1])	Skew (4Q[0:1])
LH	$-2t_U$	$-4t_U$	$-4t_U$
ML	$-1t_U$	$-2t_U$	$-2t_U$
MM	Zero skew	Zero skew	Zero skew
MH	$+1t_U$	$+2t_U$	$+2t_U$
HL	$+2t_U$	$+4t_U$	$+4t_U$
HM	$+3t_U$	$+6t_U$	$+6t_U$
HH	$+4t_U$	Divide by 4	Inverted ^[6]

In addition to determining whether the outputs synchronize to the rising or the falling edge of the reference signal, the 3-level PE/HD pin controls the output buffer drive strength as indicated in Table 6.

The CY7B9950 RoboClock® features split power supply buses for Banks 1 and 2, Bank 3 and Bank 4, which enables the user to obtain both 3.3 V and 2.5 V output signals from one device. The core power supply (V_{DD}) must be set at a level that is equal to or higher than any one of the output power supplies.

Table 6. PE/HD Settings

PE/HD	Synchronization	Output drive strength ^[7]
L	Negative	Low drive
M	Positive	High drive
H	Positive	Low drive

Table 7. Power Supply Constraints

V_{DD}	V_{DDQ1} ^[8]	V_{DDQ3} ^[8]	V_{DDQ4} ^[8]
3.3 V	3.3 V or 2.5 V	3.3 V or 2.5 V	3.3 V or 2.5 V
2.5 V	2.5 V	2.5 V	2.5 V

Governing Agencies

The following agencies provide specifications that apply to the CY7B9950 RoboClock®. The agency name and relevant specification is listed below.

Table 8. Governing Agencies and Specifications

Agency name	Specification
JEDEC	JESD 51 (theta JA), JESD 65 (skew, jitter)
IEEE	1596.3 (jitter specs)
UL-194_V0	94 (moisture grading)
MIL	883E method 1012.1 (therma theta JC)

Absolute Maximum Conditions

Parameter	Description	Condition	Min	Max	Unit
V _{DD}	Supply voltage		–	4.6	V
V _{IN(MIN)}	Input voltage	Relative to V _{SS}	V _{SS} – 0.3	–	V
V _{IN(MAX)}	Input voltage	Relative to V _{DD}	–	V _{DD} + 0.3	V
T _S	Temperature, storage	Non-functional	–65	150	°C
T _J	Temperature, junction	Functional	–	155	°C
∅ _{JC}	Dissipation, junction to case	Mil-Spec 883E Method 1012.1	–	42	°C/W
∅ _{JA}	Dissipation, junction to ambient	JEDEC (JESD 51)	–	105	°C/W
ESD _{HBM}	ESD protection (human body model)	MIL-STD-883, Method 3015	2000	–	V
UL-94	Flammability rating	At 1/8 in.	V–0		
MSL	Moisture sensitivity level		3		
FIT	Failure in time	Manufacturing testing	10		ppm

Operating Conditions

Parameter	Description	Condition	Min	Max	Unit
V _{DD}	Operating voltage	2.5 V ± 5%	2.375	2.625	V
		3.3 V ± 10%	2.97	3.63	V
T _A	Temperature, operating ambient		–40	85	°C

DC Electrical Specifications at 2.5 V

Parameter	Description	Condition	Min	Max	Unit	
V_{IL}	Input low voltage	REF, FB and sOE# Inputs	–	0.7	V	
V_{IH}	Input high voltage		1.7	–	V	
$V_{IHH}^{[9]}$	Input high voltage	3-level inputs (TEST, FS, nF[1:0], PE/HD) (These pins are normally wired to V_{DD} , GND, or unconnected.)	$V_{DD} - 0.4$	–	V	
$V_{IMM}^{[9]}$	Input MID voltage		$V_{DD}/2 - 0.2$	$V_{DD}/2 + 0.2$	V	
$V_{ILL}^{[9]}$	Input low voltage		–	0.4	V	
I_{IL}	Input leakage current	$V_{IN} = V_{DD}/GND$, $V_{DD} = \text{max.}$ (REF and FB inputs)	–5	5	μA	
I_3	3-level input DC current	HIGH, $V_{IN} = V_{DD}$	3-level inputs (TEST, FS, nF[1:0], PE/HD)	–	200	μA
		MID, $V_{IN} = V_{DD}/2$		–50	50	μA
		LOW, $V_{IN} = V_{SS}$		–200	–	μA
I_{PU}	Input pull-up current	$V_{IN} = V_{SS}$, $V_{DD} = \text{max.}$	–25	–	μA	
I_{PD}	Input pull-down current	$V_{IN} = V_{DD}$, $V_{DD} = \text{max.}$, (sOE#)	–	100	μA	
V_{OL}	Output low voltage	$I_{OL} = 12 \text{ mA}$ (PE/HD = L/H), (nQ[0:1])	–	0.4	V	
		$I_{OL} = 20 \text{ mA}$ (PE/HD = MID), (nQ[0:1])	–	0.4	V	
V_{OH}	Output high voltage	$I_{OH} = -12 \text{ mA}$ (PE/HD = L/H), (nQ[0:1])	2.0	–	V	
		$I_{OH} = -20 \text{ mA}$ (PE/HD = MID), (nQ[0:1])	2.0	–	V	
I_{DDQ}	Quiescent supply current	$V_{DD} = \text{max.}$, TEST = MID, REF = LOW, sOE# = LOW, outputs not loaded	–	2	mA	
I_{DD}	Dynamic supply current	At 100 MHz	150		mA	
C_{IN}	Input pin capacitance		4		pF	

Note

9. These inputs are normally wired to V_{DD} , GND or unconnected. Internal termination resistors bias unconnected inputs to $V_{DD}/2$.

DC Electrical Specifications at 3.3 V

Parameter	Description	Condition	Min	Max	Unit	
V_{IL}	Input LOW voltage	REF, FB and sOE# Inputs	–	0.8	V	
V_{IH}	Input HIGH voltage		2.0	–	V	
$V_{IHH}^{[10]}$	Input HIGH voltage	3-level inputs (TEST, FS, nF[1:0], PE/HD) (These pins are normally wired to V_{DD} , GND or unconnected.)	$V_{DD} - 0.6$	–	V	
$V_{IMM}^{[10]}$	Input MID voltage		$V_{DD}/2 - 0.3$	$V_{DD}/2 + 0.3$	V	
$V_{ILL}^{[10]}$	Input LOW voltage		–	0.6	V	
I_{IL}	Input leakage current	$V_{IN} = V_{DD}/G_{ND}$, $V_{DD} = \text{max.}$ (REF and FB inputs)	–5	5	μA	
I_3	3-level input DC current	HIGH, $V_{IN} = V_{DD}$	3-level inputs (TEST, FS, nF[1:0], DS[1:0], PD#/DIV, PE/HD)	–	200	μA
		MID, $V_{IN} = V_{DD}/2$		–50	50	μA
		LOW, $V_{IN} = V_{SS}$		–200	–	μA
I_{PU}	Input pull-up current	$V_{IN} = V_{SS}$, $V_{DD} = \text{max.}$	–100	–	μA	
I_{PD}	Input pull-down current	$V_{IN} = V_{DD}$, $V_{DD} = \text{max.}$, (sOE#)	–	100	μA	
V_{OL}	Output LOW voltage	$I_{OL} = 12 \text{ mA}$ (PE/HD = L/H), (nQ[0:1])	–	0.4	V	
		$I_{OL} = 24 \text{ mA}$ (PE/HD = MID), (nQ[0:1])	–	0.4	V	
V_{OH}	Output HIGH voltage	$I_{OH} = -12 \text{ mA}$ (PE/HD = L/H), (nQ[0:1])	2.4	–	V	
		$I_{OH} = -24 \text{ mA}$ (PE/HD = MID), (nQ[0:1])	2.4	–	V	
I_{DDQ}	Quiescent supply current	$V_{DD} = \text{max.}$, TEST = MID, REF = LOW, sOE# = LOW, outputs not loaded	–	2	mA	
I_{DD}	Dynamic supply current	At 100 MHz	230		mA	
C_{IN}	Input pin capacitance		4		pF	

Note

10. These inputs are normally wired to V_{DD} , GND or unconnected. Internal termination resistors bias unconnected inputs to $V_{DD}/2$.

Thermal Resistance

Parameter ^[11]	Description	Test Conditions	32-pin TQFP	Unit
θ_{JA}	Thermal resistance (junction to ambient)	Test conditions follow standard test methods and procedures for measuring thermal impedance, in accordance with EIA/JESD51.	65	°C/W
θ_{JC}	Thermal resistance (junction to case)		12	°C/W

AC Test Loads and Waveforms

Figure 2. AC Test Loads

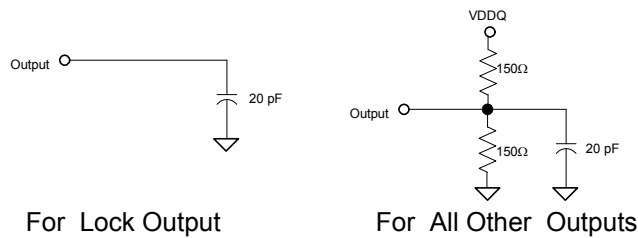

Figure 3. Output Waveforms

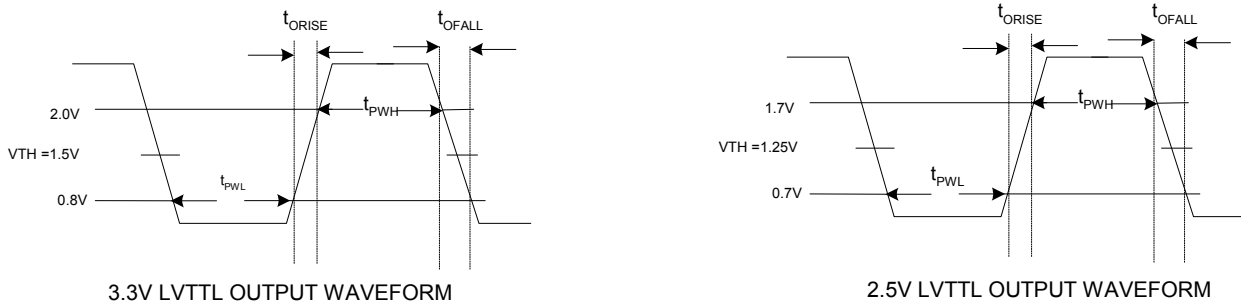
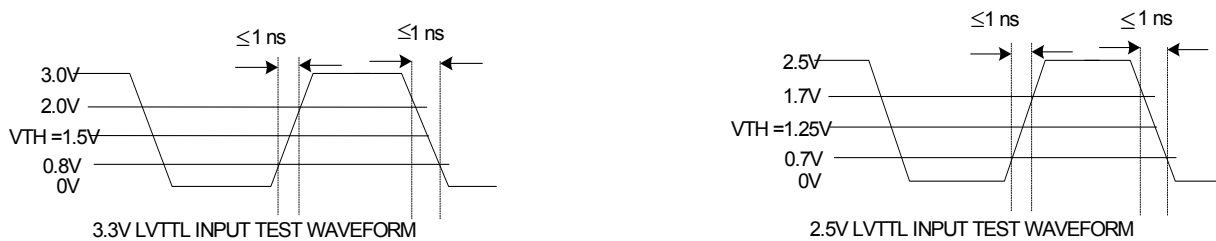

Figure 4. Test Waveforms



Note

11. These parameters are guaranteed by design and are not tested.

AC Input Specifications

Parameter	Description	Condition	Min	Max	Unit
T_{R,T_F}	Input rise/fall time	0.8 V–2.0 V	–	10	ns/V
T_{PWC}	Input clock pulse	HIGH or LOW	2	–	ns
T_{DCIN}	Input duty cycle		10	90	%
F_{REF}	Reference input frequency	FS = LOW	6	50	MHz
		FS = MID	12	100	
		FS = HIGH	24	200	

Switching Characteristics

Parameter	Description	Condition	Min	Typ	Max	Unit
F _{OR}	Output frequency range		6	–	200	MHz
VCO _{LR}	VCO lock range		200	–	400	MHz
VCO _{LBW}	VCO loop bandwidth		0.25	–	3.5	MHz
t _{SKEWPR}	Matched-pair skew ^[10]	Skew between the earliest and the latest output transitions within the same bank.	–	50	100	ps
t _{SKEW0}	Output-output skew ^[10]	Skew between the earliest and the latest output transitions among all outputs at 0t _U .	–	100	200	ps
t _{SKEW1}		Skew between the earliest and the latest output transitions among all outputs for which the same phase delay has been selected.	–	100	200	ps
t _{SKEW2}		Skew between the nominal output rising edge to the inverted output falling edge.	–	–	500	ps
t _{SKEW3}	Output-output skew ^[10]	Skew between non-inverted outputs running at different frequencies.	–	–	500	ps
t _{SKEW4}		Skew between nominal to inverted outputs running at different frequencies.	–	–	500	ps
t _{SKEW5}		Skew between nominal outputs at different power supply levels.	–	–	650	ps
t _{PART}	Part-part skew	Skew between the outputs of any two devices under identical settings and conditions (V _{DDQ} , V _{DD} , temp, air flow, frequency, etc.).	–	–	750	ps
t _{PD0}	Ref-FB propagation delay ^[11]		–250	–	+250	ps
t _{ODCV}	Output duty cycle	F _{out} < 100 MHz, measured at V _{DD} /2	48	49.5/50.5	52	%
		F _{out} > 100 MHz, measured at V _{DD} /2	45	48/52	55	
t _{PWH}	Output high time deviation from 50%	Measured at 2.0V for V _{DD} = 3.3 V and at 1.7 V for V _{DD} = 2.5V.	–	–	1.5	ns
t _{PWL}	Output low time deviation from 50%	Measured at 0.8 V for V _{DD} = 3.3 V and at 0.7 V for V _{DD} = 2.5 V.	–	–	2.0	ns
t _R /t _F	Output rise/fall time	Measured at 0.8 V–2.0 V for V _{DD} = 3.3 V and 0.7 V–1.7 V for V _{DD} = 2.5 V.	0.15	–	1.5	ns
t _{LOCK}	PLL lock time ^[12,13]		–	–	0.5	ms
t _{CCJ}	Cycle-cycle jitter	Divide by one output frequency, FS = L, FB = divide by 1, 2, 4.	–	50	100	ps
		Divide by one output frequency, FS = M/H, FB = divide by 1, 2, 4.	–	70	150	ps

Notes

10. Test load = 20 pF, terminated to V_{CC}/2. All outputs are equally loaded.

11. t_{PD} is measured at 1.5 V for V_{DD} = 3.3 V and at 1.25 V for V_{DD} = 2.5 V with REF rise/fall times of 0.5 ns between 0.8 V–2.0 V.

12. t_{LOCK} is the time that is required before outputs synchronize to REF. This specification is valid with stable power supplies which are within normal operating limits.

13. Lock detector circuit may be unreliable for input frequencies lower than 4 MHz, or for input signals which contain significant jitter.

AC Timing Definitions

Figure 5. Timing Definitions

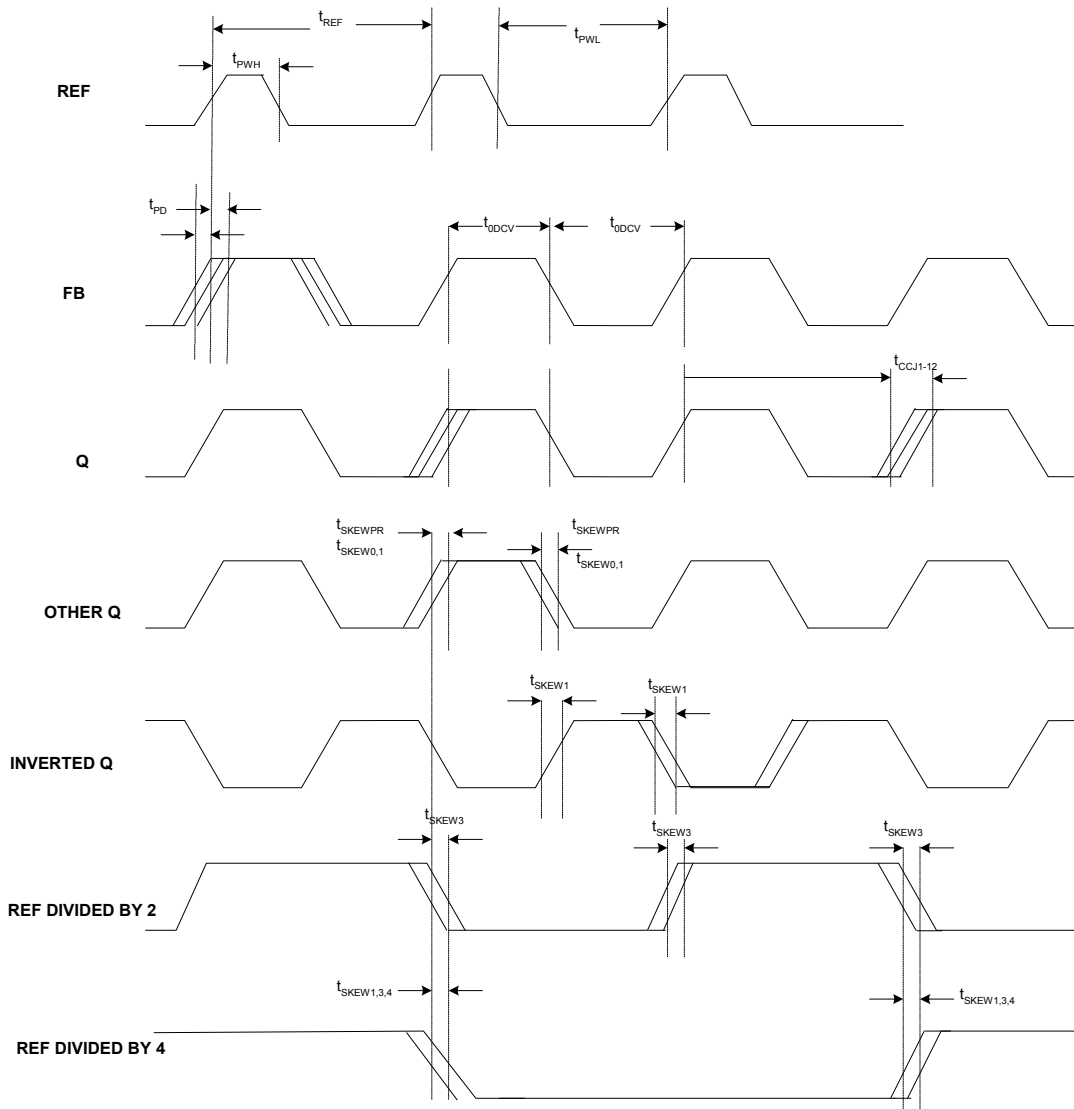

Ordering Information

Part Number	Package Type	Product Flow
Pb-free		
CY7B9950 RoboClock®AXC	32-pin TQFP	Commercial, 0° to 70 °C
CY7B9950 RoboClock®AXCT	32-pin TQFP – Tape and Reel	Commercial, 0° to 70 °C
CY7B9950 RoboClock®AXI	32-pin TQFP	Industrial, –40 °C to 85 °C
CY7B9950 RoboClock®AXIT	32-pin TQFP – Tape and Reel	Industrial, –40 °C to 85 °C

Ordering Code Definitions

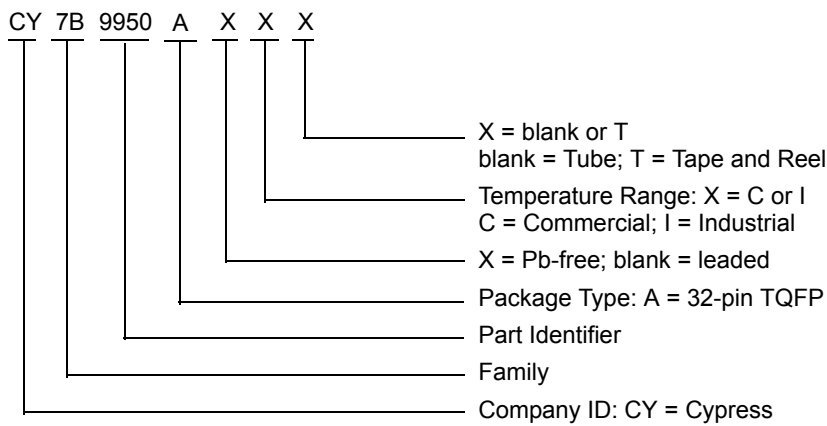

Package Diagram

Figure 6. 32-pin TQFP (7 × 7 × 1.0 mm) A3210 Package Outline, 51-85063

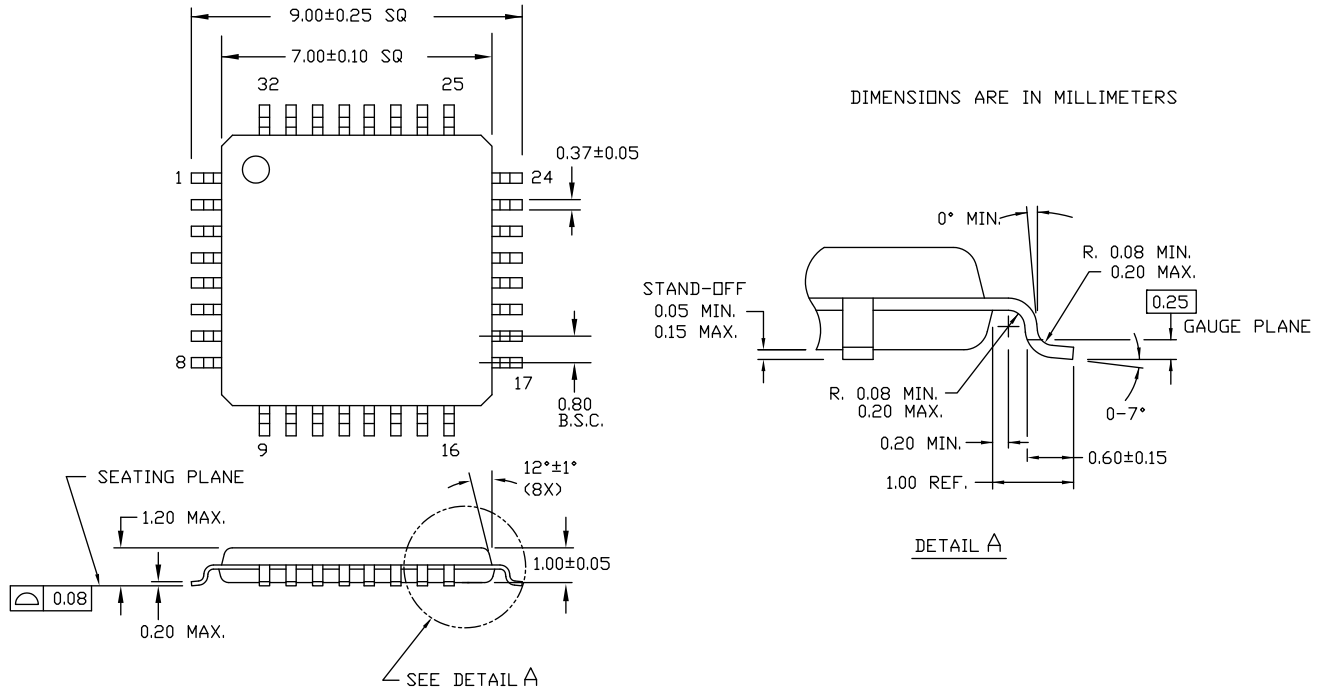

51-85063 *E

Acronyms

Table 9. Acronyms Used in this Document

Acronym	Description
CLKOUT	Clock Output
CMOS	Complementary Metal Oxide Semiconductor
DPM	Die Pick Map
EPROM	Erasable Programmable Read Only Memory
NTSC	National Television System Committee
OE	Output Enable
PAL	Phase Alternate Line
PD	Power Down
PLL	Phase Locked Loop
PPM	Parts Per Million
TTL	Transistor-Transistor Logic

Document Conventions

Units of Measure

Table 10. Units of Measure

Symbol	Unit of Measure	Symbol	Unit of Measure
°C	degree Celsius	μW	microwatt
dB	decibel	mA	milliampere
fC	femtoCoulomb	mm	millimeter
fF	femtofarad	ms	millisecond
Hz	hertz	mV	millivolt
KB	1024 bytes	nA	nanoampere
Kbit	1024 bits	ns	nanosecond
kHz	kilohertz	nV	nanovolt
kΩ	kilohm	Ω	ohm
MHz	megahertz	pA	picoampere
MΩ	megaohm	pF	picofarad
μA	microampere	pp	peak-to-peak
μF	microfarad	ppm	parts per million
μH	microhenry	ps	picosecond
μs	microsecond	sps	samples per second
μV	microvolt	σ	sigma: one standard deviation
μVrms	microvolts root-mean-square		

Document History Page

Document Title: CY7B9950 RoboClock®, 2.5/3.3 V, 200 MHz High-Speed Multi-Phase PLL Clock Buffer Document Number: 38-07338				
Rev.	ECN No.	Submission Date	Orig. of Change	Description of Change
**	121663	11/25/02	RGL	New data sheet.
*A	122548	12/12/02	RGL	Updated DC Electrical Specifications at 2.5 V : Updated details in “Condition” column corresponding to V_{IH} , V_{IM} and V_{IL} parameters (Removed PD#/DIV and DS[1:0]). Updated DC Electrical Specifications at 3.3 V : Updated details in “Condition” column corresponding to V_{IH} , V_{IM} and V_{IL} parameters (Removed PD#/DIV and DS[1:0]).
*B	124646	03/05/03	RGL	Updated Pin Definitions : Updated details in “Description” column corresponding to pin 27 and pin 12. Updated Absolute Maximum Conditions : Changed minimum value of V_{DD} parameter corresponding to Test Condition “Functional @ 2.5V ± 5%” from 2.25 V to 2.375 V. Changed maximum value of V_{DD} parameter corresponding to Test Condition “Functional @ 2.5V ± 5%” from 2.75 V to 2.625 V.
*C	433662	See ECN	RGL	Updated Features : Updated details corresponding to “Output-output skew” and “Cycle-cycle jitter”. Updated Switching Characteristics : Added a column “Typ”. Updated Ordering Information : Updated part numbers.
*D	1562063	See ECN	PYG / AESA	Updated Ordering Information : Updated part numbers. Added a column “Status”.
*E	2894960	03/17/10	KVM	Updated Device Configuration : Updated Table 5 : Fixed typo in output skew settings. Updated Absolute Maximum Conditions : Updated V_{DD} value. Added Operating Conditions . Updated Ordering Information : Updated part numbers. Removed the column “Status”. Updated Package Diagram . Updated Sales, Solutions, and Legal Information : Updated links.
*F	3058099	10/14/10	BASH	Added Ordering Code Definitions . Added Acronyms and Units of Measure . Updated to new template.
*G	4176123	10/28/2013	CINM	Updated Package Diagram : spec 51-85063 – Changed revision from *C to *D. Updated to new template. Completing Sunset Review.
*H	4571728	11/17/2014	CINM	Updated Functional Description : Added “For a complete list of related documentation, click here. ” at the end.
*I	4764256	05/13/2015	XHT	Updated Absolute Maximum Conditions : Changed value of MSL parameter from 1 to 3. Updated Package Diagram : spec 51-85063 – Changed revision from *D to *E.
*J	5257087	05/03/2016	PSR	Added Thermal Resistance . Updated to new template.

Document History Page(continued)

Document Title: CY7B9950 RoboClock®, 2.5/3.3 V, 200 MHz High-Speed Multi-Phase PLL Clock Buffer				
Document Number: 38-07338				
Rev.	ECN No.	Submission Date	Orig. of Change	Description of Change
*K	5493833	10/25/2016	XHT	Updated to new template. Completing Sunset Review.
*L	5992901	12/13/2017	AESATMP8	Updated logo and Copyright.

Sales, Solutions, and Legal Information

Worldwide Sales and Design Support

Cypress maintains a worldwide network of offices, solution centers, manufacturer's representatives, and distributors. To find the office closest to you, visit us at [Cypress Locations](#).

Products

ARM® Cortex® Microcontrollers	cypress.com/arm
Automotive	cypress.com/automotive
Clocks & Buffers	cypress.com/clocks
Interface	cypress.com/interface
Internet of Things	cypress.com/iot
Memory	cypress.com/memory
Microcontrollers	cypress.com/mcu
PSoC	cypress.com/psoc
Power Management ICs	cypress.com/pmic
Touch Sensing	cypress.com/touch
USB Controllers	cypress.com/usb
Wireless Connectivity	cypress.com/wireless

PSoC® Solutions

[PSoC 1](#) | [PSoC 3](#) | [PSoC 4](#) | [PSoC 5LP](#) | [PSoC 6](#)

Cypress Developer Community

[Forums](#) | [WICED IOT Forums](#) | [Projects](#) | [Video](#) | [Blogs](#) | [Training](#) | [Components](#)

Technical Support

cypress.com/support



© Cypress Semiconductor Corporation, 2002-2017. This document is the property of Cypress Semiconductor Corporation and its subsidiaries, including Spansion LLC ("Cypress"). This document, including any software or firmware included or referenced in this document ("Software"), is owned by Cypress under the intellectual property laws and treaties of the United States and other countries worldwide. Cypress reserves all rights under such laws and treaties and does not, except as specifically stated in this paragraph, grant any license under its patents, copyrights, trademarks, or other intellectual property rights. If the Software is not accompanied by a license agreement and you do not otherwise have a written agreement with Cypress governing the use of the Software, then Cypress hereby grants you a personal, non-exclusive, nontransferable license (without the right to sublicense) (1) under its copyright rights in the Software (a) for Software provided in source code form, to modify and reproduce the Software solely for use with Cypress hardware products, only internally within your organization, and (b) to distribute the Software in binary code form externally to end users (either directly or indirectly through resellers and distributors), solely for use on Cypress hardware product units, and (2) under those claims of Cypress's patents that are infringed by the Software (as provided by Cypress, unmodified) to make, use, distribute, and import the Software solely for use with Cypress hardware products. Any other use, reproduction, modification, translation, or compilation of the Software is prohibited.

TO THE EXTENT PERMITTED BY APPLICABLE LAW, CYPRESS MAKES NO WARRANTY OF ANY KIND, EXPRESS OR IMPLIED, WITH REGARD TO THIS DOCUMENT OR ANY SOFTWARE OR ACCOMPANYING HARDWARE, INCLUDING, BUT NOT LIMITED TO, THE IMPLIED WARRANTIES OF MERCHANTABILITY AND FITNESS FOR A PARTICULAR PURPOSE. To the extent permitted by applicable law, Cypress reserves the right to make changes to this document without further notice. Cypress does not assume any liability arising out of the application or use of any product or circuit described in this document. Any information provided in this document, including any sample design information or programming code, is provided only for reference purposes. It is the responsibility of the user of this document to properly design, program, and test the functionality and safety of any application made of this information and any resulting product. Cypress products are not designed, intended, or authorized for use as critical components in systems designed or intended for the operation of weapons, weapons systems, nuclear installations, life-support devices or systems, other medical devices or systems (including resuscitation equipment and surgical implants), pollution control or hazardous substances management, or other uses where the failure of the device or system could cause personal injury, death, or property damage ("Unintended Uses"). A critical component is any component of a device or system whose failure to perform can be reasonably expected to cause the failure of the device or system, or to affect its safety or effectiveness. Cypress is not liable, in whole or in part, and you shall and hereby do release Cypress from any claim, damage, or other liability arising from or related to all Unintended Uses of Cypress products. You shall indemnify and hold Cypress harmless from and against all claims, costs, damages, and other liabilities, including claims for personal injury or death, arising from or related to any Unintended Uses of Cypress products.

Cypress, the Cypress logo, Spansion, the Spansion logo, and combinations thereof, WICED, PSoC, CapSense, EZ-USB, F-RAM, and Traveo are trademarks or registered trademarks of Cypress in the United States and other countries. For a more complete list of Cypress trademarks, visit cypress.com. Other names and brands may be claimed as property of their respective owners.

Looking for pricing, stock, or lifecycle information?

Click below to explore more details on WIN SOURCE:

-  [View CY7B9950AXC on WIN SOURCE](#)
-  [Cypress Semiconductor Corp Information](#)

Optimize Your Supply Chain with WIN SOURCE Solutions

-  Global Sourcing Solution
-  Obsolete Management
-  Cost Control Management
-  Shortage Management
-  Alternative Solution
-  Excess Inventory Management