

# 16-Bit, Dual Voltage Output DIGITAL-TO-ANALOG CONVERTER

## FEATURES

- **LOW POWER:** 4mW
- **UNIPOLAR OR BIPOLAR OPERATION**
- **SETTLING TIME:** 10 $\mu$ s to 0.003% FSR
- **15-BIT LINEARITY AND MONOTONICITY:**  $-40^{\circ}\text{C}$  to  $+85^{\circ}\text{C}$
- **RESET TO MID-SCALE (DAC7642) OR ZERO-SCALE (DAC7643)**
- **DATA READBACK**
- **DOUBLE-BUFFERED DATA INPUTS**

## APPLICATIONS

- **PROCESS CONTROL**
- **CLOSED-LOOP SERVO-CONTROL**
- **MOTOR CONTROL**
- **DATA ACQUISITION SYSTEMS**
- **DAC-PER-PIN PROGRAMMERS**

## DESCRIPTION

The DAC7642 and DAC7643 are dual channel, 16-bit, voltage output Digital-to-Analog Converters (DACs) which provide 15-bit monotonic performance over the specified temperature range. They accept 16-bit parallel input data, have double-buffered DAC input logic (allowing simultaneous update of all DACs), and provide a readback mode of the internal input registers. Programmable asynchronous reset clears all registers to a mid-scale code of 8000<sub>H</sub> (DAC7642) or to a zero-scale code of 0000<sub>H</sub> (DAC7643). These DACs can operate from a single +5V supply or from +5V and -5V supplies, providing an output range of 0 to +2.5V or -2.5V to +2.5V, respectively.

Low power and small size per DAC make the DAC7642 and DAC7643 ideal for automatic test equipment, DAC-per-pin programmers, data acquisition systems, and closed-loop servo-control. The DAC7642 and DAC7643 are available in a LQFP-32 package and specified over a  $-40^{\circ}\text{C}$  to  $+85^{\circ}\text{C}$  temperature range.

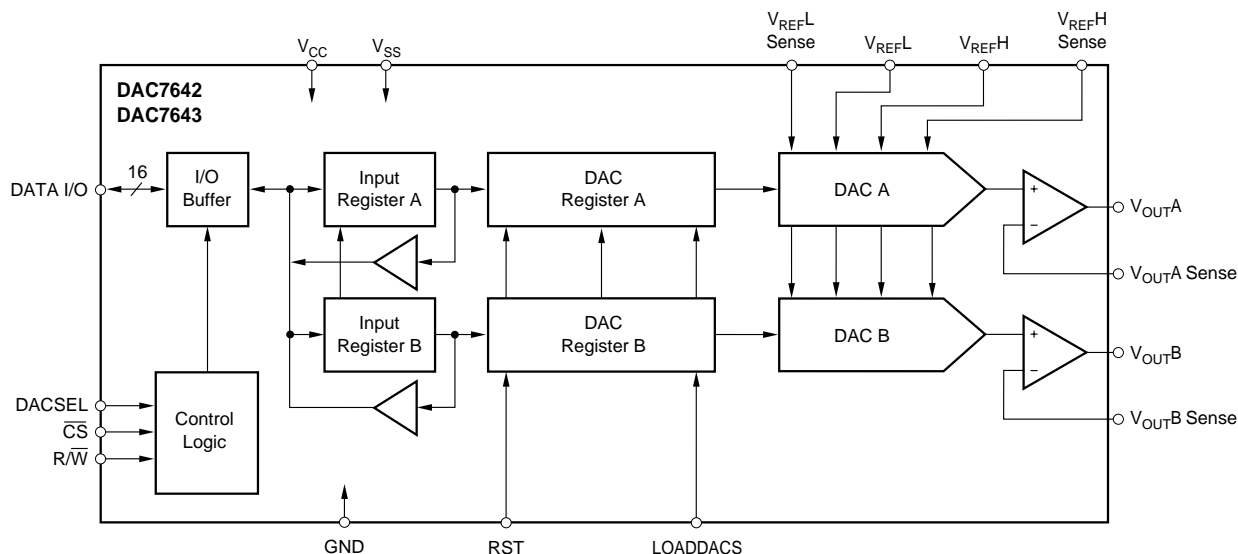

Please be aware that an important notice concerning availability, standard warranty, and use in critical applications of Texas Instruments semiconductor products and disclaimers thereto appears at the end of this data sheet.

## ABSOLUTE MAXIMUM RATINGS<sup>(1)</sup>

$V_{CC}$ to $V_{SS}$ .....	-0.3V to 11V
$V_{CC}$ to GND .....	-0.3V to 5.5V
$V_{REFL}$ to $V_{SS}$ .....	-0.3V to ( $V_{CC} - V_{SS}$ )
$V_{CC}$ to $V_{REFH}$ .....	-0.3V to ( $V_{CC} - V_{SS}$ )
$V_{REFH}$ to $V_{REFL}$ .....	-0.3V to ( $V_{CC} - V_{SS}$ )
Digital Input Voltage to GND .....	-0.3V to $V_{CC} + 0.3V$
Digital Output Voltage to GND .....	-0.3V to $V_{CC} + 0.3V$
Maximum Junction Temperature .....	+150°C
Operating Temperature Range .....	-40°C to +85°C
Storage Temperature Range .....	-65°C to +125°C
Lead Temperature (soldering, 10s) .....	+300°C

NOTE: (1) Stresses above those listed under "Absolute Maximum Ratings" may cause permanent damage to the device. Exposure to absolute maximum conditions for extended periods may affect device reliability.



## ELECTROSTATIC DISCHARGE SENSITIVITY

This integrated circuit can be damaged by ESD. Texas Instruments recommends that all integrated circuits be handled with appropriate precautions. Failure to observe proper handling and installation procedures can cause damage.

ESD damage can range from subtle performance degradation to complete device failure. Precision integrated circuits may be more susceptible to damage because very small parametric changes could cause the device not to meet its published specifications.

## PACKAGE/ORDERING INFORMATION

PRODUCT	MONOTONICITY	PACKAGE-LEAD	PACKAGE DESIGNATOR <sup>(1)</sup>	SPECIFIED TEMPERATURE RANGE	PACKAGE MARKING	ORDERING NUMBER	TRANSPORT MEDIA, QUANTITY
DAC7642VF	14 Bits	LQFP-32	VF	-40°C to +85°C	DAC7642	DAC7642VFT	Tape and Reel, 250
"	"	"	"	"	"	DAC7642VFR	Tape and Reel, 1000
DAC7642VFB	15 Bits	LQFP-32	VF	-40°C to +85°C	DAC7642B	DAC7642VFBT	Tape and Reel, 250
"	"	"	"	"	"	DAC7642VFB R	Tape and Reel, 1000
DAC7643VF	14 Bits	LQFP-32	VF	-40°C to +85°C	DAC7643	DAC7643VFT	Tape and Reel, 250
"	"	"	"	"	"	DAC7643VFR	Tape and Reel, 1000
DAC7643VFB	15 Bits	LQFP-32	VF	-40°C to +85°C	DAC7643B	DAC7643VFB T	Tape and Reel, 250
"	"	"	"	"	"	DAC7643VFB R	Tape and Reel, 1000

NOTE: (1) For the most current specifications and package information, refer to our web site at [www.ti.com](http://www.ti.com).

# ELECTRICAL CHARACTERISTICS (Dual Supply)

At  $T_A = T_{MIN}$  to  $T_{MAX}$ ,  $V_{CC} = +5V$ ,  $V_{SS} = -5V$ ,  $V_{REFH} = +2.5V$ , and  $V_{REFL} = -2.5V$ , unless otherwise noted.

PARAMETER	CONDITIONS	DAC7642VF DAC7643VF			DAC7642VFB DAC7643VFB			UNITS
		MIN	TYP	MAX	MIN	TYP	MAX	
<b>ACCURACY</b>								
Linearity Error			±3	±4		±2	±3	LSB
Linearity Match			±4			±2		LSB
Differential Linearity Error			±2	±3		±1	±2	LSB
Monotonicity, $T_{MIN}$ to $T_{MAX}$		14			15			Bits
Bipolar Zero Error			±1	±3		*	*	mV
Bipolar Zero Error Drift			5	10		*	*	ppm/°C
Full-Scale Error			±1	±3		*	*	mV
Full-Scale Error Drift			5	10		*	*	ppm/°C
Bipolar Zero Matching	Channel-to-Channel Matching		±1	±3		±1	±3	mV
Full-Scale Matching	Channel-to-Channel Matching		±1	±3		±1	±3	mV
Power-Supply Rejection Ratio (PSRR)	At Full-Scale		10	100		*	*	ppm/V
<b>ANALOG OUTPUT</b>								
Voltage Output	$R_L = 10k\Omega$	$V_{REFL}$		$V_{REFH}$	*		*	V
Output Current		-1.25		+1.25	*		*	mA
Maximum Load Capacitance	No Oscillation		500			*		pF
Short-Circuit Current			-10, +30			*		mA
Short-Circuit Duration	$GND, V_{CC}$ or $V_{SS}$		Indefinite			*		
<b>REFERENCE INPUT</b>								
Ref High Input Voltage Range		$V_{REFL} + 1.25$		+2.5	*		*	V
Ref Low Input Voltage Range		-2.5		$V_{REFH} - 1.25$	*		*	V
Ref High Input Current			500			*		$\mu A$
Ref Low Input Current			-500			*		$\mu A$
<b>DYNAMIC PERFORMANCE</b>								
Settling Time	To ±0.003%, 5V Output Step		8	10		*	*	$\mu s$
Channel-to-Channel Crosstalk	See Figure 5		0.5			*		LSB
Digital Feedthrough			2			*		nV-s
Output Noise Voltage	$f = 10kHz$		60			*		$nV/\sqrt{Hz}$
DAC Glitch	7FFF <sub>H</sub> to 8000 <sub>H</sub> or 8000 <sub>H</sub> to 7FFF <sub>H</sub>		40			*		nV-s
<b>DIGITAL INPUT</b>								
$V_{IH}$		$0.7 \cdot V_{CC}$			*			V
$V_{IL}$				$0.3 \cdot V_{CC}$			*	V
$I_{IH}$				±10			*	$\mu A$
$I_{IL}$				±10			*	$\mu A$
<b>DIGITAL OUTPUT</b>								
$V_{OH}$	$I_{OH} = -0.8mA$	3.6	4.5		*	*		V
$V_{OL}$	$I_{OL} = 1.2mA$		0.3	0.4		*	*	V
<b>POWER SUPPLY</b>								
$V_{CC}$		+4.75	+5.0	+5.25	*	*	*	V
$V_{SS}$		-5.25	-5.0	-4.75	*	*	*	V
$I_{CC}$			0.7	1.1		*	*	mA
$I_{SS}$		-1.2	-0.8		*	*	*	mA
Power			7.5	11.5		*	*	mW
<b>TEMPERATURE RANGE</b>								
Specified Performance		-40		+85	*		*	°C

\* Specifications same as DAC7642VF and DAC7643VF.

# ELECTRICAL CHARACTERISTICS (Single Supply)

At  $T_A = T_{MIN}$  to  $T_{MAX}$ ,  $V_{CC} = +5V$ ,  $V_{SS} = 0V$ ,  $V_{REFH} = +2.5V$ , and  $V_{REFL} = 0V$ , unless otherwise noted.

PARAMETER	CONDITIONS	DAC7642VF DAC7643VF			DAC7642VFB DAC7643VFB			UNITS
		MIN	TYP	MAX	MIN	TYP	MAX	
<b>ACCURACY</b>								
Linearity Error <sup>(1)</sup>			±3	±4		±2	±3	LSB
Linearity Match			±4			±2		LSB
Differential Linearity Error			±2	±3		±1	±2	LSB
Monotonicity, $T_{MIN}$ to $T_{MAX}$		14			15			Bits
Zero-Scale Error			±1	±3		*	*	mV
Zero-Scale Error Drift			5	10		*	*	ppm/°C
Full-Scale Error			±1	±3		*	*	mV
Full-Scale Error Drift			5	10		*	*	ppm/°C
Zero-Scale Matching	Channel-to-Channel Matching		±1	±3		±1	±3	mV
Full-Scale Matching	Channel-to-Channel Matching		±1	±3		±1	±3	mV
Power-Supply Rejection Ratio (PSRR)	At Full-Scale		10	100		*	*	ppm/V
<b>ANALOG OUTPUT</b>								
Voltage Output	$R_L = 10k\Omega$	0		$V_{REFH}$	*		*	V
Output Current		-1.25		$+1.25$	*		*	mA
Maximum Load Capacitance	No Oscillation		500			*		pF
Short-Circuit Current			-10, +30			*		mA
Short-Circuit Duration	GND or $V_{CC}$		Indefinite			*		
<b>REFERENCE INPUT</b>								
Ref High Input Voltage Range		$V_{REFL} + 1.25$		+2.5	*		*	V
Ref Low Input Voltage Range		0		$V_{REFH} - 1.25$	*		*	V
Ref High Input Current			250			*		μA
Ref Low Input Current			-250			*		μA
<b>DYNAMIC PERFORMANCE</b>								
Settling Time	To ±0.003%, 2.5V Output Step		8	10		*	*	μs
Channel-to-Channel Crosstalk	See Figure 6		0.5			*		LSB
Digital Feedthrough			2			*		nV-s
Output Noise Voltage, $f = 10kHz$			60			*		$nV/\sqrt{Hz}$
DAC Glitch	$7FFF_H$ to $8000_H$ or $8000_H$ to $7FFF_H$		40			*		nV-s
<b>DIGITAL INPUT</b>								
$V_{IH}$		$0.7 \cdot V_{CC}$			*			V
$V_{IL}$				$0.3 \cdot V_{CC}$			*	V
$I_{IH}$				±10			*	μA
$I_{IL}$				±10			*	μA
<b>DIGITAL OUTPUT</b>								
$V_{OH}$	$I_{OH} = -0.8mA$	3.6	4.5		*	*		V
$V_{OL}$	$I_{OL} = 1.2mA$		0.3	0.4		*	*	V
<b>POWER SUPPLY</b>								
$V_{CC}$		+4.75	+5.0	+5.25	*	*	*	V
$V_{SS}$		0	0	0	*	*	*	V
$I_{CC}$			0.5	0.9		*	*	mA
Power			2.5	4.5		*	*	mW
<b>TEMPERATURE RANGE</b>								
Specified Performance		-40		+85	*		*	°C

\* Specifications same as DAC7642VF and DAC7643VF.

NOTE: (1) If  $V_{SS} = 0V$ , specification applies at Code  $0040_H$  and above due to possible negative zero-scale error.

## PIN CONFIGURATION

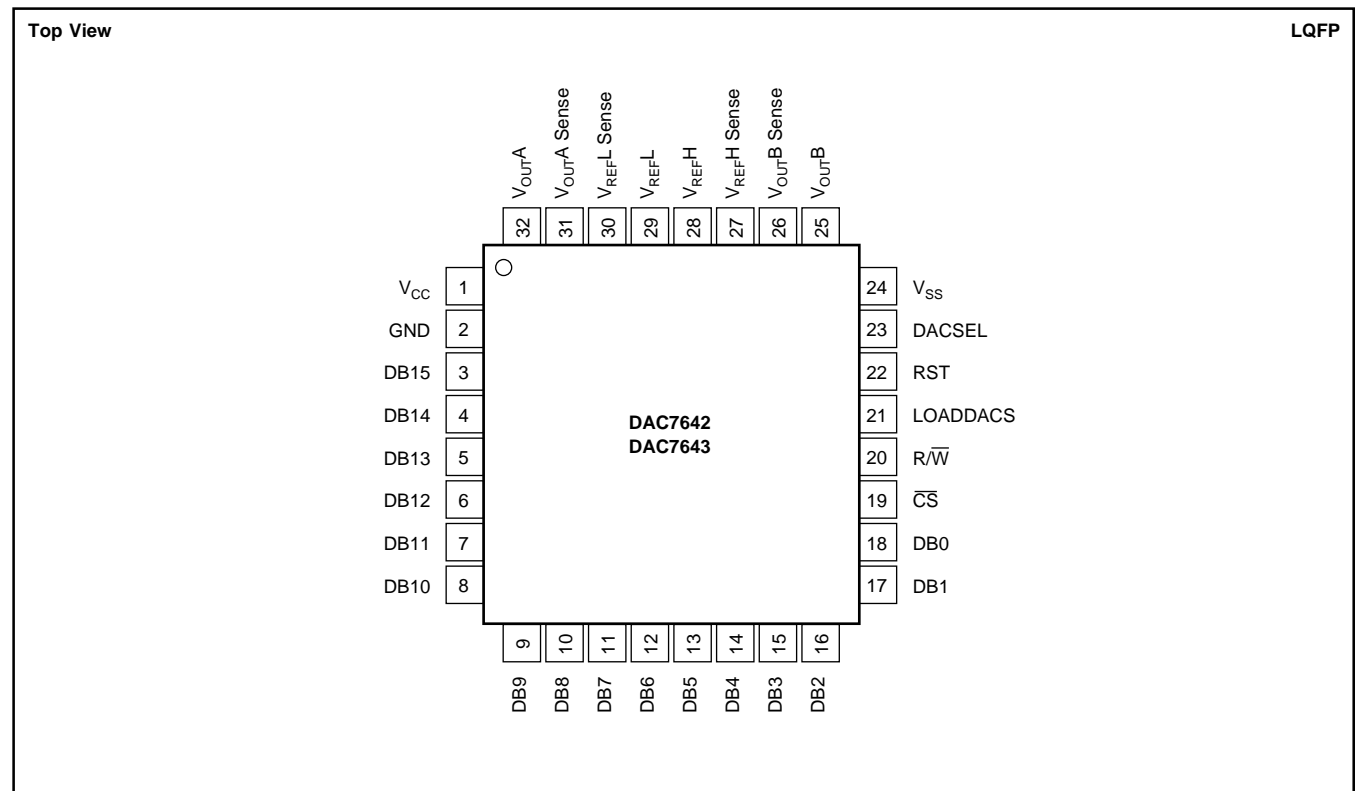

## PIN DESCRIPTIONS

PIN	NAME	DESCRIPTION	PIN	NAME	DESCRIPTION
1	V <sub>CC</sub>	Positive Power Supply	20	R/ $\bar{W}$	Enabled by $\bar{CS}$ , Controls Data Read from and Write to the Input Registers.
2	GND	Ground	21	LOADDACs	DAC Output Registers Load Control. Rising edge triggered. Transfers Data from the Input Registers to the DAC Registers, Updating the DAC Output.
3	DB15	Data Bit 15, MSB	22	RST	Reset, Rising Edge Triggered. DAC7642 resets to mid-scale, DAC7643 resets to zero. (Resets Both Input Registers and DAC Registers)
4	DB14	Data Bit 14	23	DACSEL	Enabled by $\bar{CS}$ . Selects the individual DAC Input Registers. (LOW Selects Register A, HIGH Selects Register B)
5	DB13	Data Bit 13	24	V <sub>SS</sub>	Negative Power Supply
6	DB12	Data Bit 12	25	V <sub>OUTB</sub>	DAC B Voltage Output
7	DB11	Data Bit 11	26	V <sub>OUTB</sub> Sense	DAC B Output Amplifier Inverting Input. Used to close the feedback loop at the load.
8	DB10	Data Bit 10	27	V <sub>REFH</sub> Sense	DAC A and B Reference High Sense Input
9	DB9	Data Bit 9	28	V <sub>REFH</sub>	DAC A and B Reference High Input
10	DB8	Data Bit 8	29	V <sub>OUTL</sub>	DAC A and B Reference Low Input
11	DB7	Data Bit 7	30	V <sub>REFL</sub> Sense	DAC A and B Reference Low Sense Input
12	DB6	Data Bit 6	31	V <sub>OUTA</sub> Sense	DAC A Output Amplifier Inverting Input. Used to close the feedback loop at the load.
13	DB5	Data Bit 5	32	V <sub>OUTA</sub>	DAC A Output Voltage
14	DB4	Data Bit 4			
15	DB3	Data Bit 3			
16	DB2	Data Bit 2			
17	DB1	Data Bit 1			
18	DB0	Data Bit 0, LSB			
19	CS	Chip Select, Active LOW			

# TYPICAL CHARACTERISTICS: $V_{SS} = 0V$

At  $T_A = +25^\circ C$ ,  $V_{CC} = +5V$ ,  $V_{SS} = 0V$ ,  $V_{REFH} = +2.5V$ ,  $V_{REFL} = 0V$ , representative unit, unless otherwise specified.

**+25°C**

LINEARITY ERROR AND  
DIFFERENTIAL LINEARITY ERROR vs CODE  
(DAC A, +25°C)

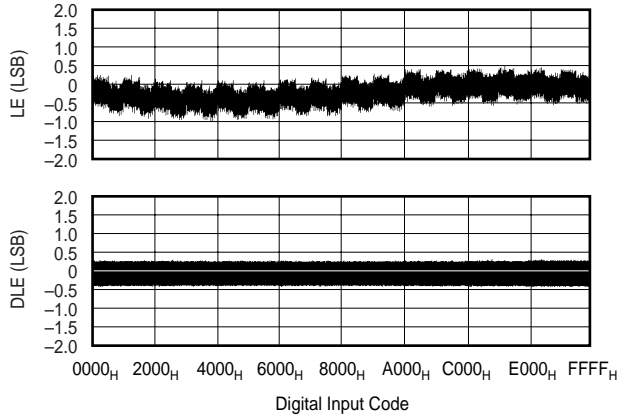

LINEARITY ERROR AND  
DIFFERENTIAL LINEARITY ERROR vs CODE  
(DAC B, +25°C)

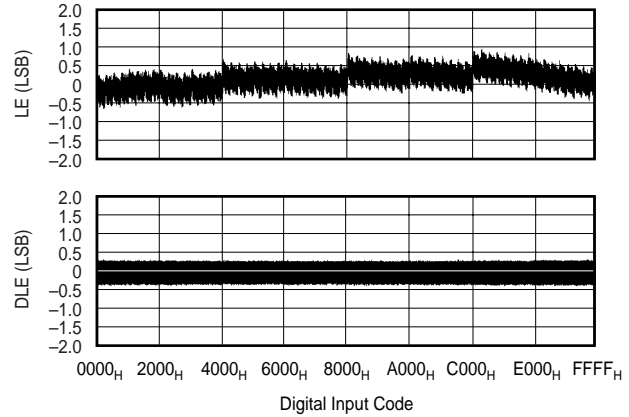

**+85°C**

LINEARITY ERROR AND  
DIFFERENTIAL LINEARITY ERROR vs CODE  
(DAC A, +85°C)

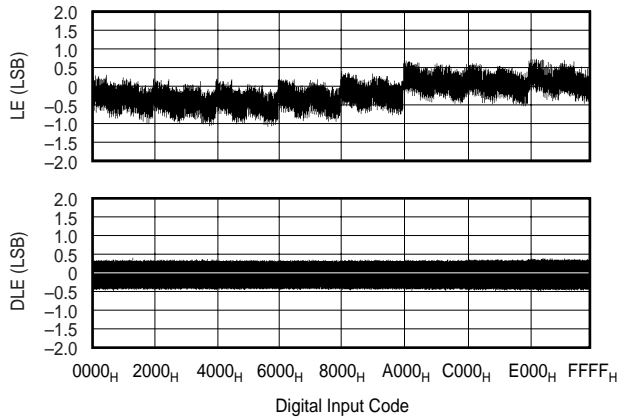

LINEARITY ERROR AND  
DIFFERENTIAL LINEARITY ERROR vs CODE  
(DAC B, +85°C)

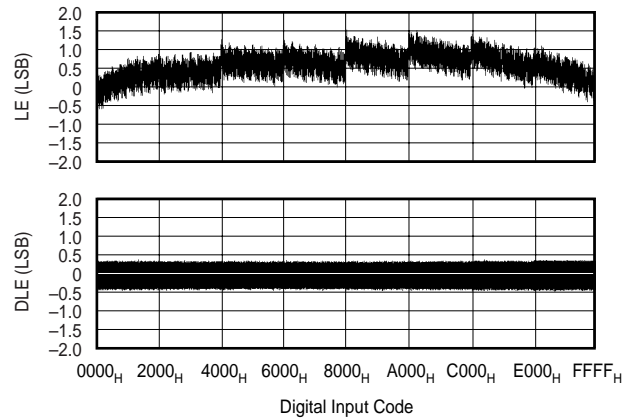

**-40°C**

LINEARITY ERROR AND  
DIFFERENTIAL LINEARITY ERROR vs CODE  
(DAC A, -40°C)

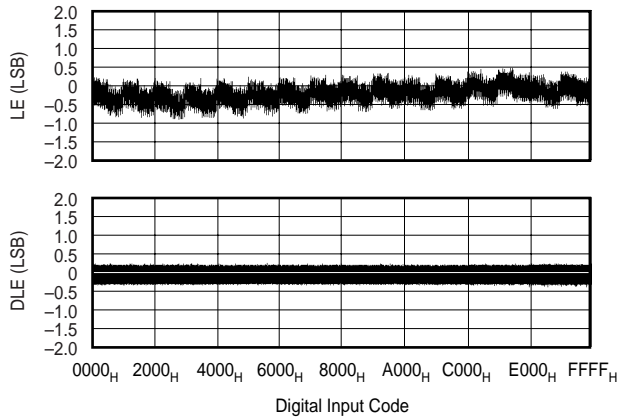

LINEARITY ERROR AND  
DIFFERENTIAL LINEARITY ERROR vs CODE  
(DAC B, -40°C)

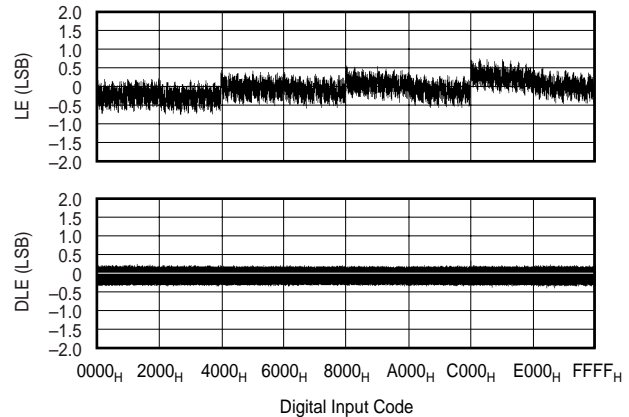

# TYPICAL CHARACTERISTICS: $V_{SS} = 0V$ (Cont.)

At  $T_A = +25^\circ C$ ,  $V_{CC} = +5V$ ,  $V_{SS} = 0V$ ,  $V_{REFH} = +2.5V$ ,  $V_{REFL} = 0V$ , representative unit, unless otherwise specified.

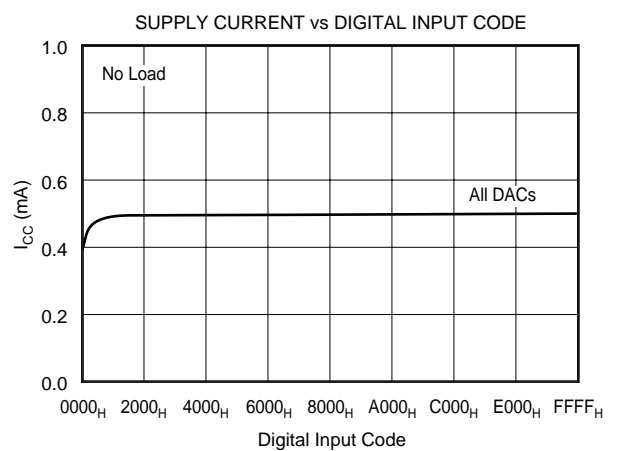
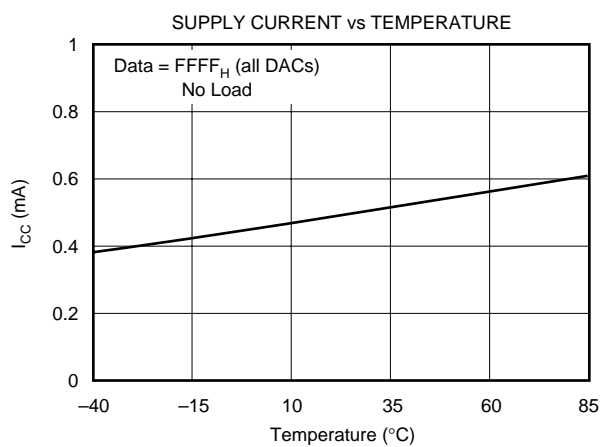
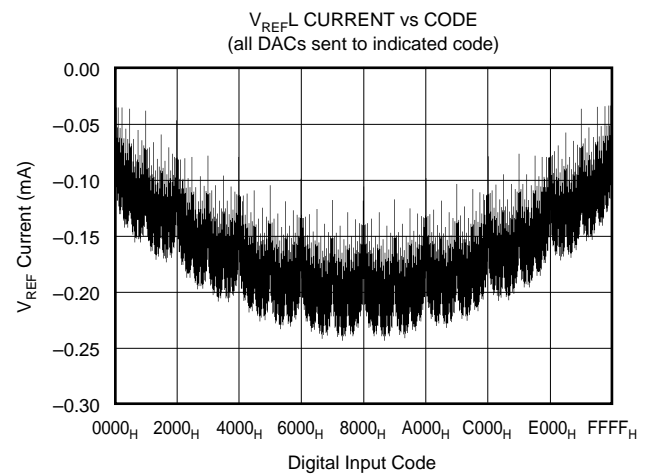
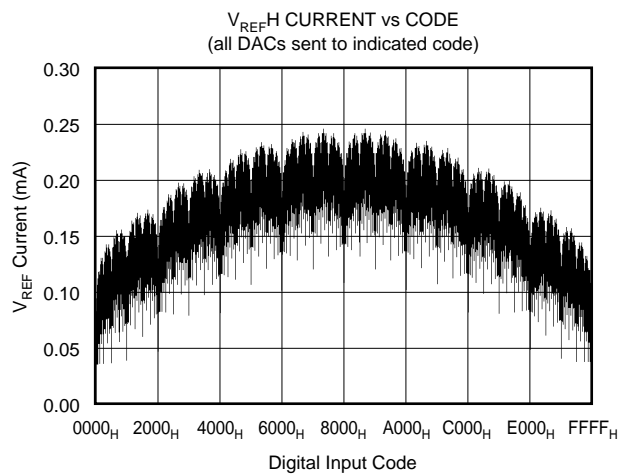
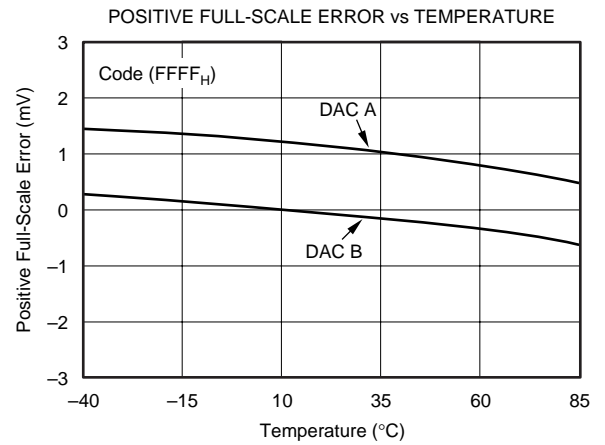
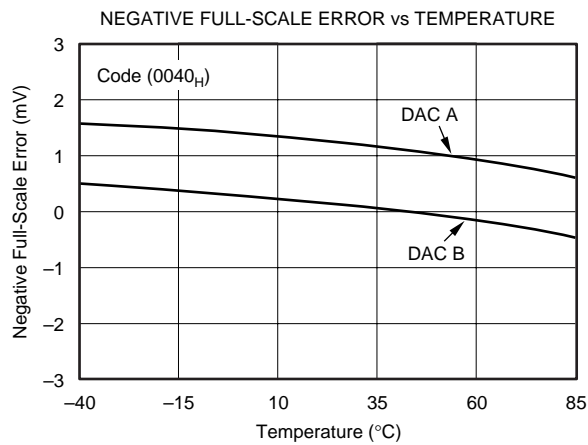

# TYPICAL CHARACTERISTICS: $V_{SS} = 0V$ (Cont.)

At  $T_A = +25^\circ C$ ,  $V_{CC} = +5V$ ,  $V_{SS} = 0V$ ,  $V_{REFH} = +2.5V$ ,  $V_{REFL} = 0V$ , representative unit, unless otherwise specified.

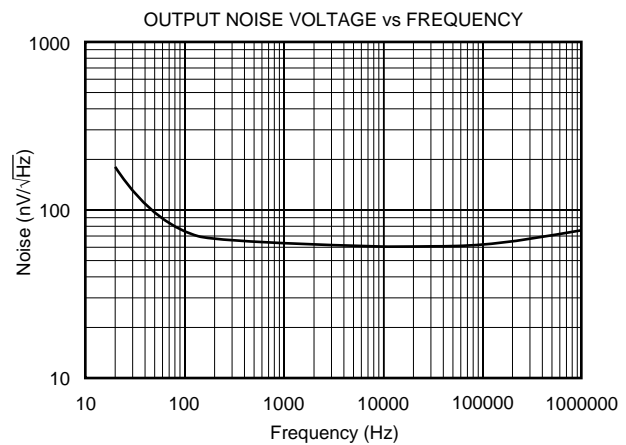
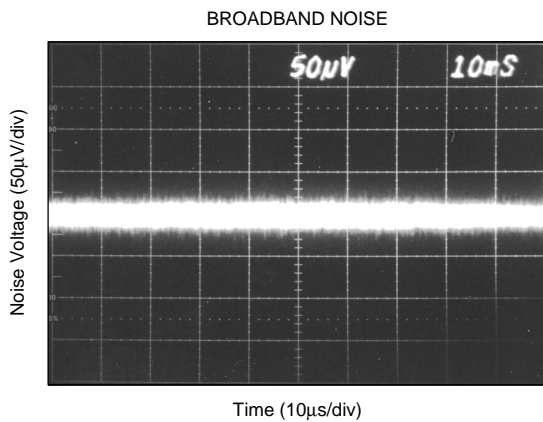
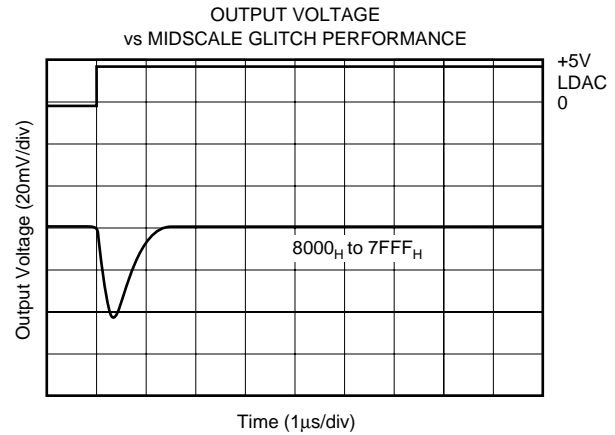
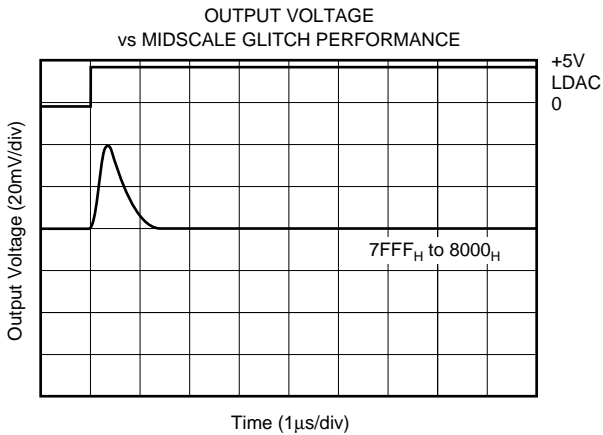
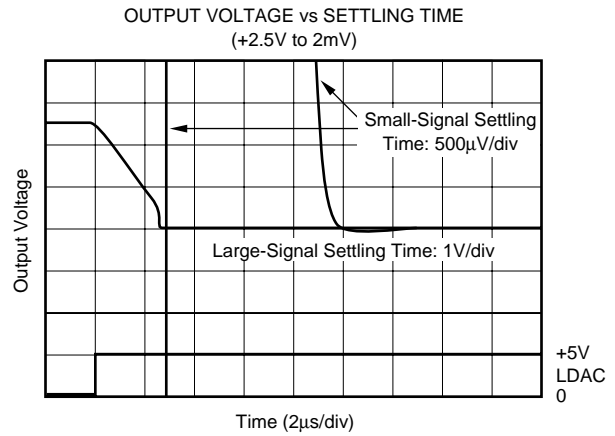
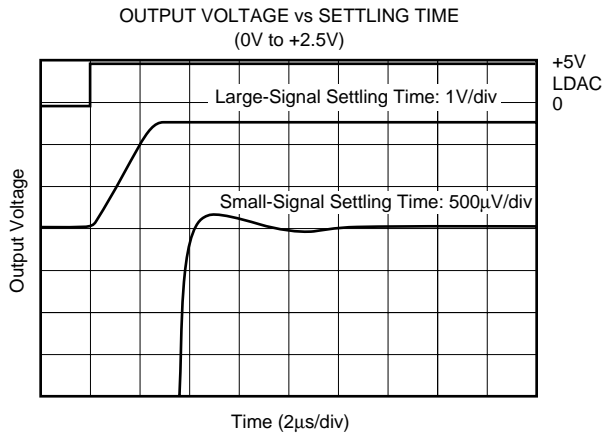

# TYPICAL CHARACTERISTICS: $V_{SS} = 0V$ (Cont.)

At  $T_A = +25^\circ C$ ,  $V_{CC} = +5V$ ,  $V_{SS} = 0V$ ,  $V_{REFH} = +2.5V$ ,  $V_{REFL} = 0V$ , representative unit, unless otherwise specified.

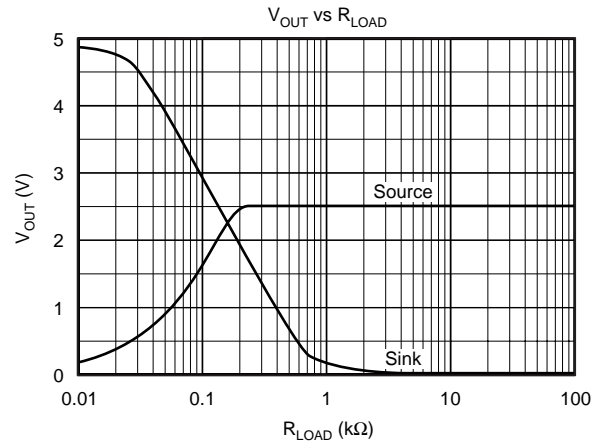
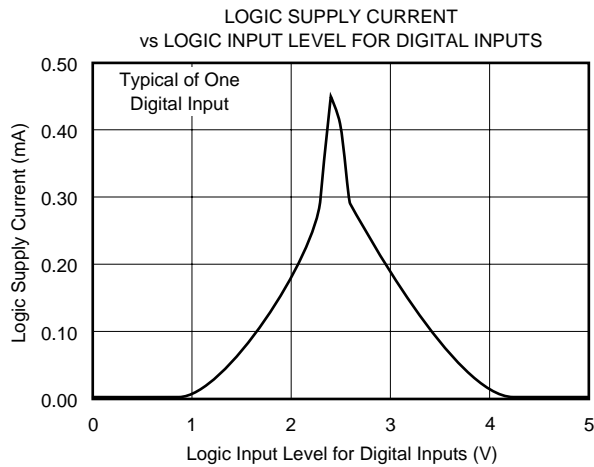

## $V_{SS} = -5V$

At  $T_A = +25^\circ C$ ,  $V_{CC} = +5V$ ,  $V_{SS} = -5V$ ,  $V_{REFH} = +2.5V$ ,  $V_{REFL} = -2.5V$ , representative unit, unless otherwise specified.

**+25°C**

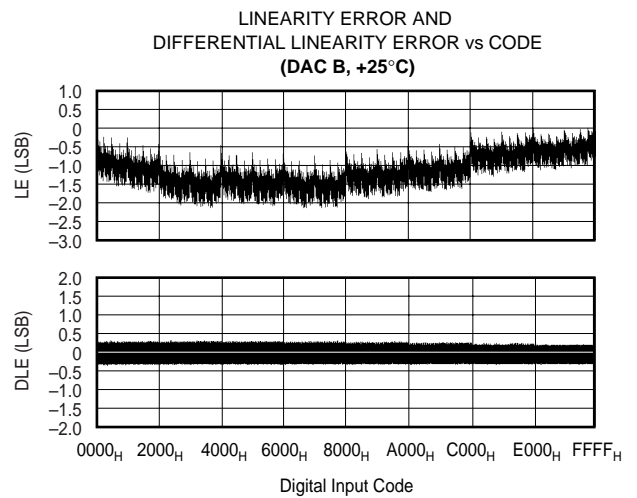
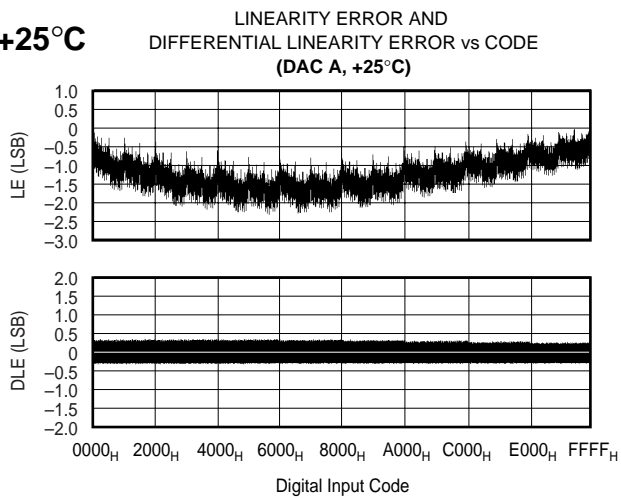

**+85°C**

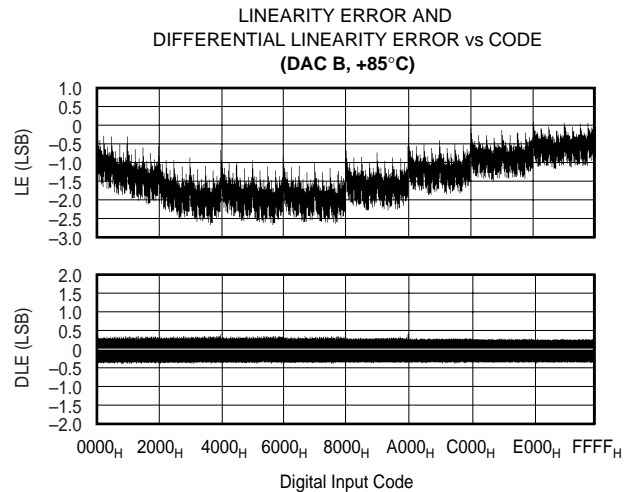
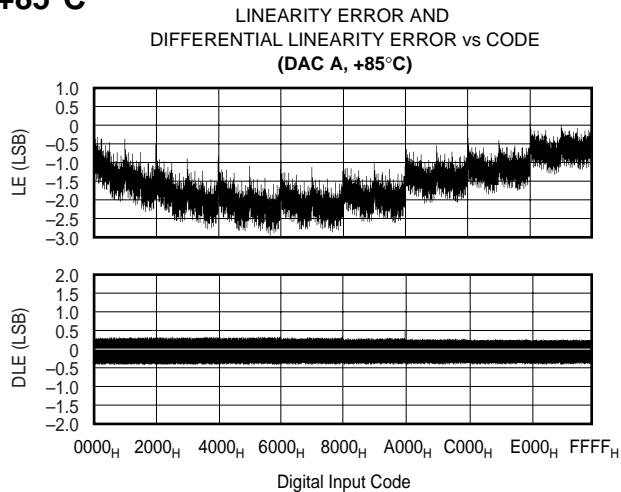

# TYPICAL CHARACTERISTICS: $V_{SS} = -5V$ (Cont.)

At  $T_A = +25^\circ C$ ,  $V_{CC} = +5V$ ,  $V_{SS} = -5V$ ,  $V_{REFH} = +2.5V$ ,  $V_{REFL} = -2.5V$ , representative unit, unless otherwise specified.

**-40°C**

LINEARITY ERROR AND DIFFERENTIAL LINEARITY ERROR vs CODE (DAC A, -40°C)

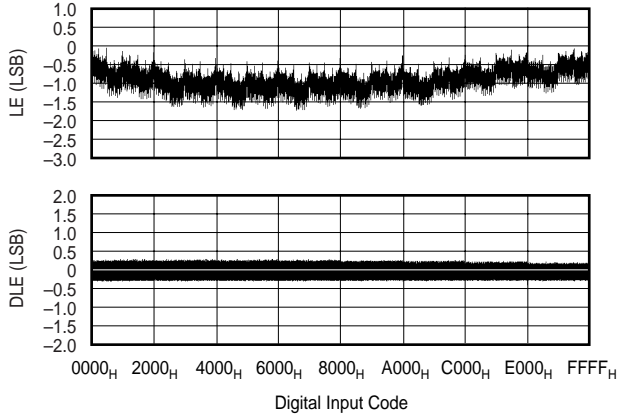

LINEARITY ERROR AND DIFFERENTIAL LINEARITY ERROR vs CODE (DAC B, -40°C)

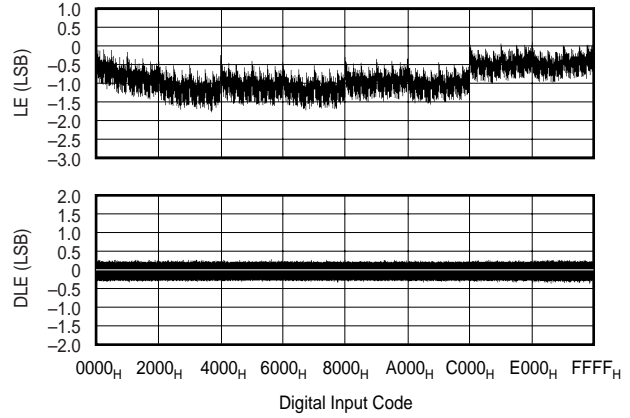

$V_{REFH}$  CURRENT vs CODE (all DACs sent to indicated code)

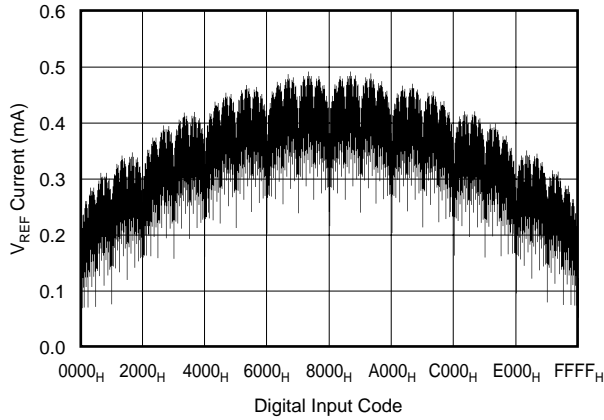

$V_{REFL}$  CURRENT vs CODE (all DACs sent to indicated code)

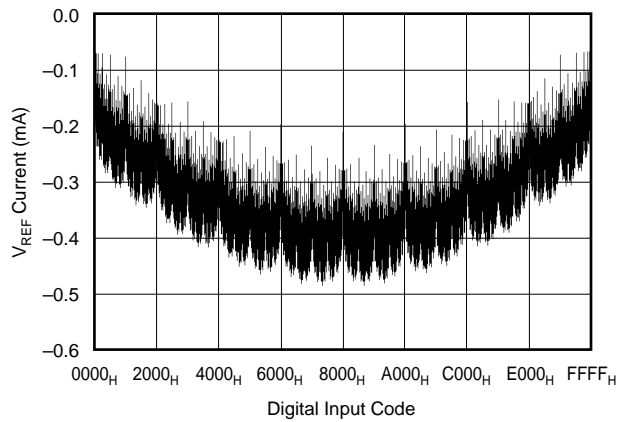

BIPOLAR ZERO ERROR vs TEMPERATURE

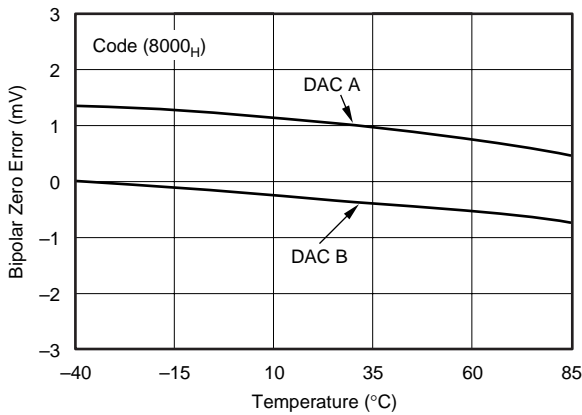

POSITIVE FULL-SCALE ERROR vs TEMPERATURE

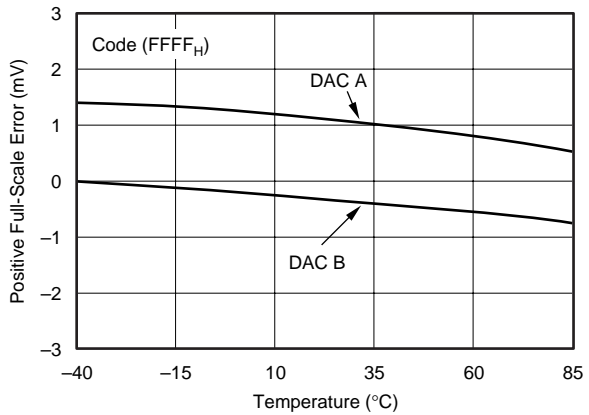

# TYPICAL CHARACTERISTICS: $V_{SS} = -5V$ (Cont.)

At  $T_A = +25^\circ C$ ,  $V_{CC} = +5V$ ,  $V_{SS} = -5V$ ,  $V_{REFH} = +2.5V$ ,  $V_{REFL} = -2.5V$ , representative unit, unless otherwise specified.

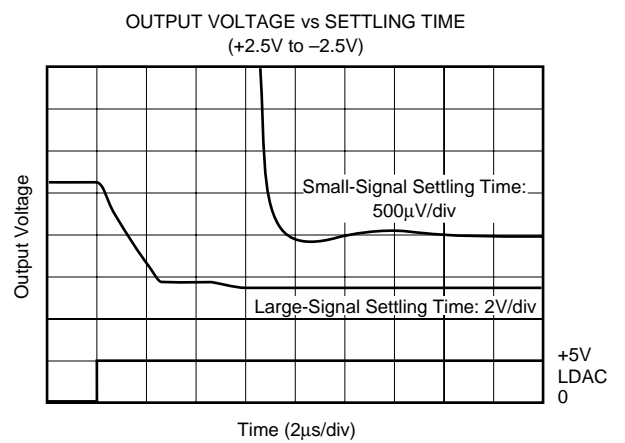
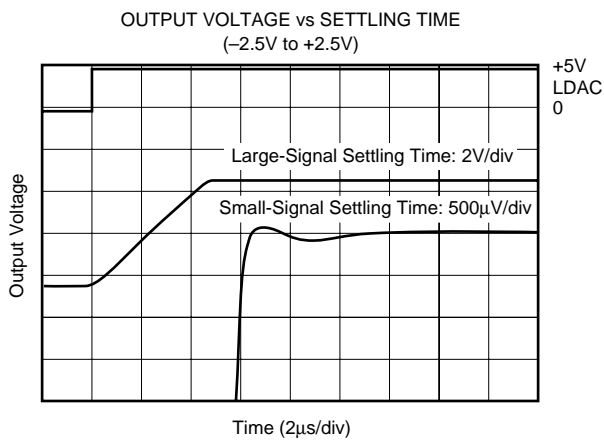
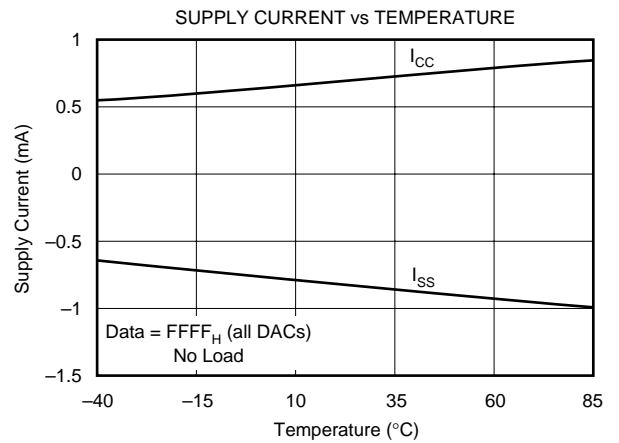
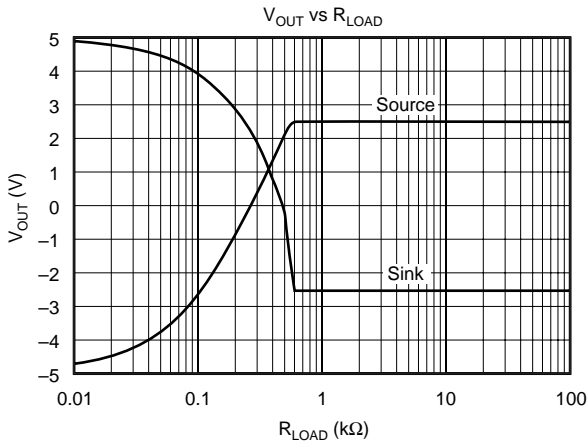
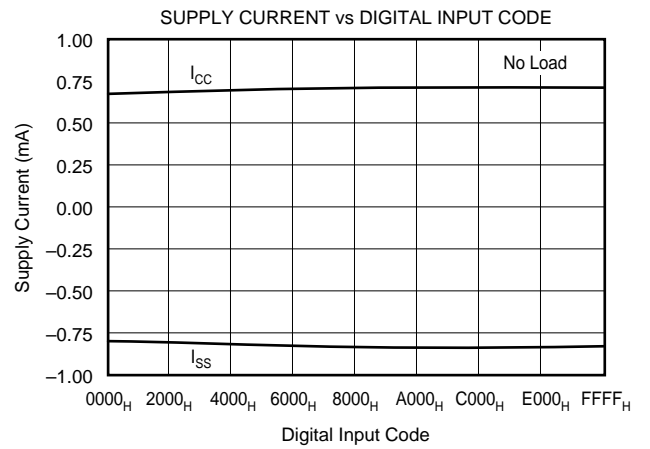
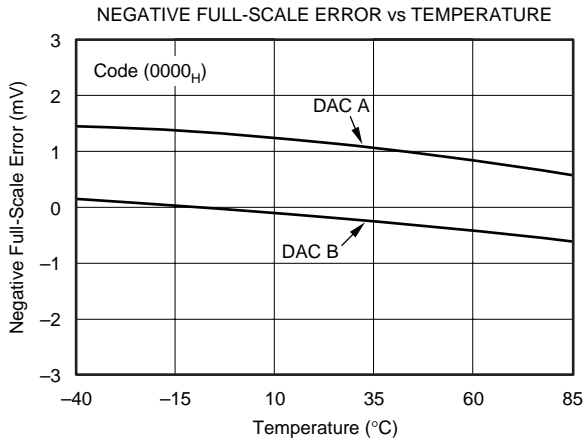

# TYPICAL CHARACTERISTICS: $V_{SS} = -5V$ (Cont.)

At  $T_A = +25^\circ C$ ,  $V_{CC} = +5V$ ,  $V_{SS} = -5V$ ,  $V_{REFH} = +2.5V$ ,  $V_{REFL} = -2.5V$ , representative unit, unless otherwise specified.

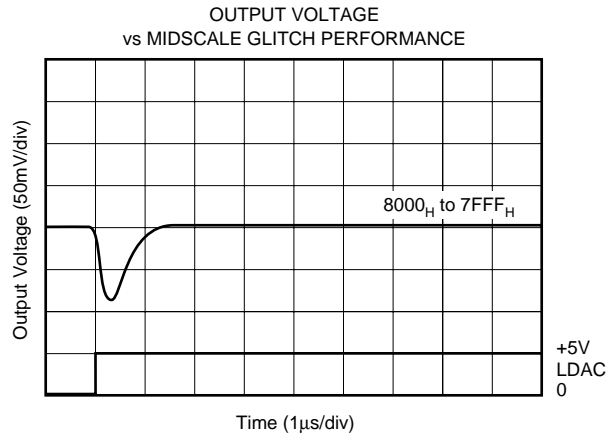
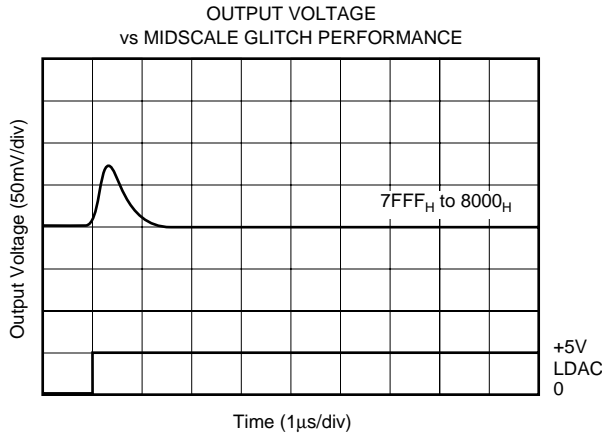

## THEORY OF OPERATION

The DAC7642 and DAC7643 are dual channel, voltage output, 16-bit DACs. The architecture is an R-2R ladder configuration with the three MSB's segmented followed by an operational amplifier that serves as a buffer. Each DAC has its own R-2R ladder network, segmented MSBs, and output op amp, as shown in Figure 1. The minimum voltage output (zero-scale) and maximum voltage output (full-scale) are set

by the external voltage references  $V_{REFL}$  and  $V_{REFH}$ , respectively. The digital input is a 16-bit parallel word and the DAC input registers offer a readback capability. The converters can be powered from either a single +5V supply or a dual  $\pm 5V$  supply. Each device offers a reset function which immediately sets all DAC output voltages, DAC registers and Input registers to mid-scale, code 8000<sub>H</sub> (DAC7642), or to zero-scale, code 0000<sub>H</sub> (DAC7643). See Figures 2 and 3 for the basic configurations of the DAC7642 and DAC7643.

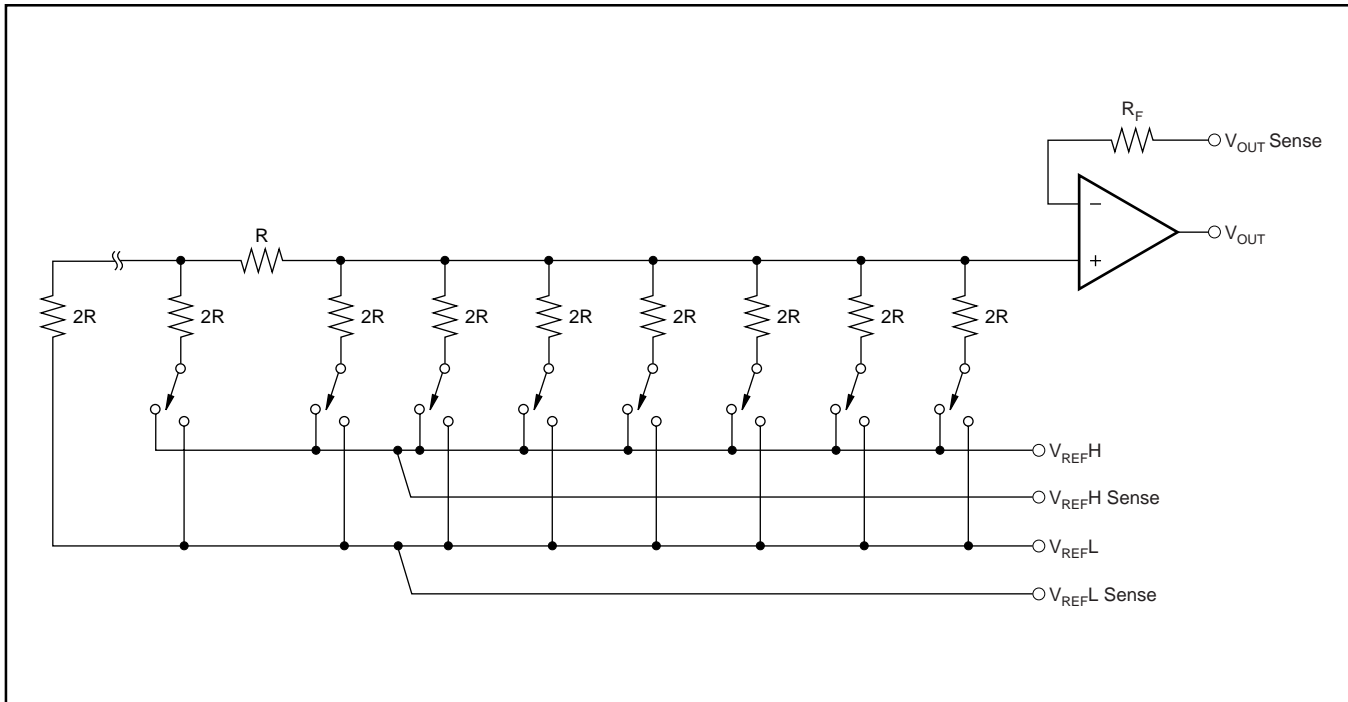

FIGURE 1. DAC7642 and DAC7643 Architecture.

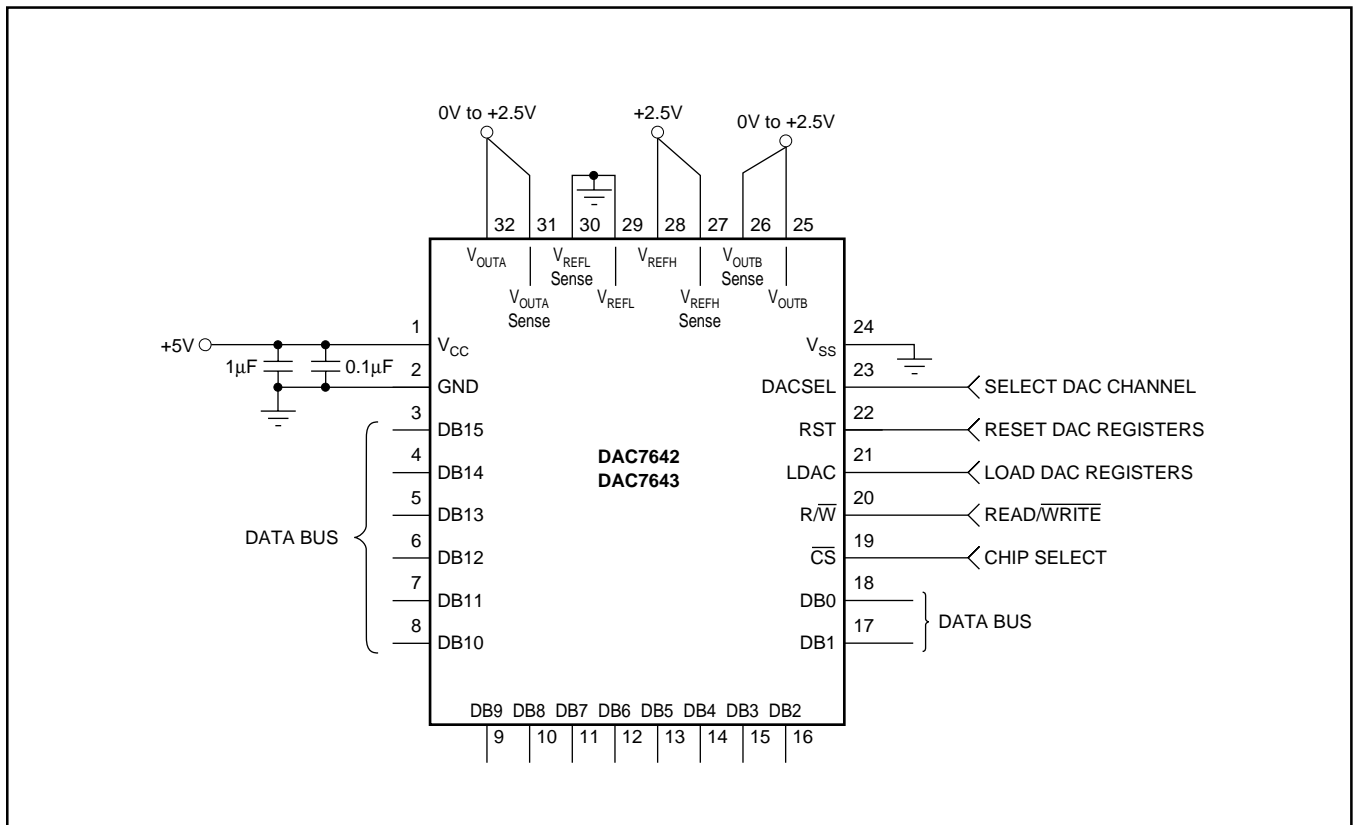

FIGURE 2. Basic Single-Supply Operation of the DAC7642 and DAC7643.

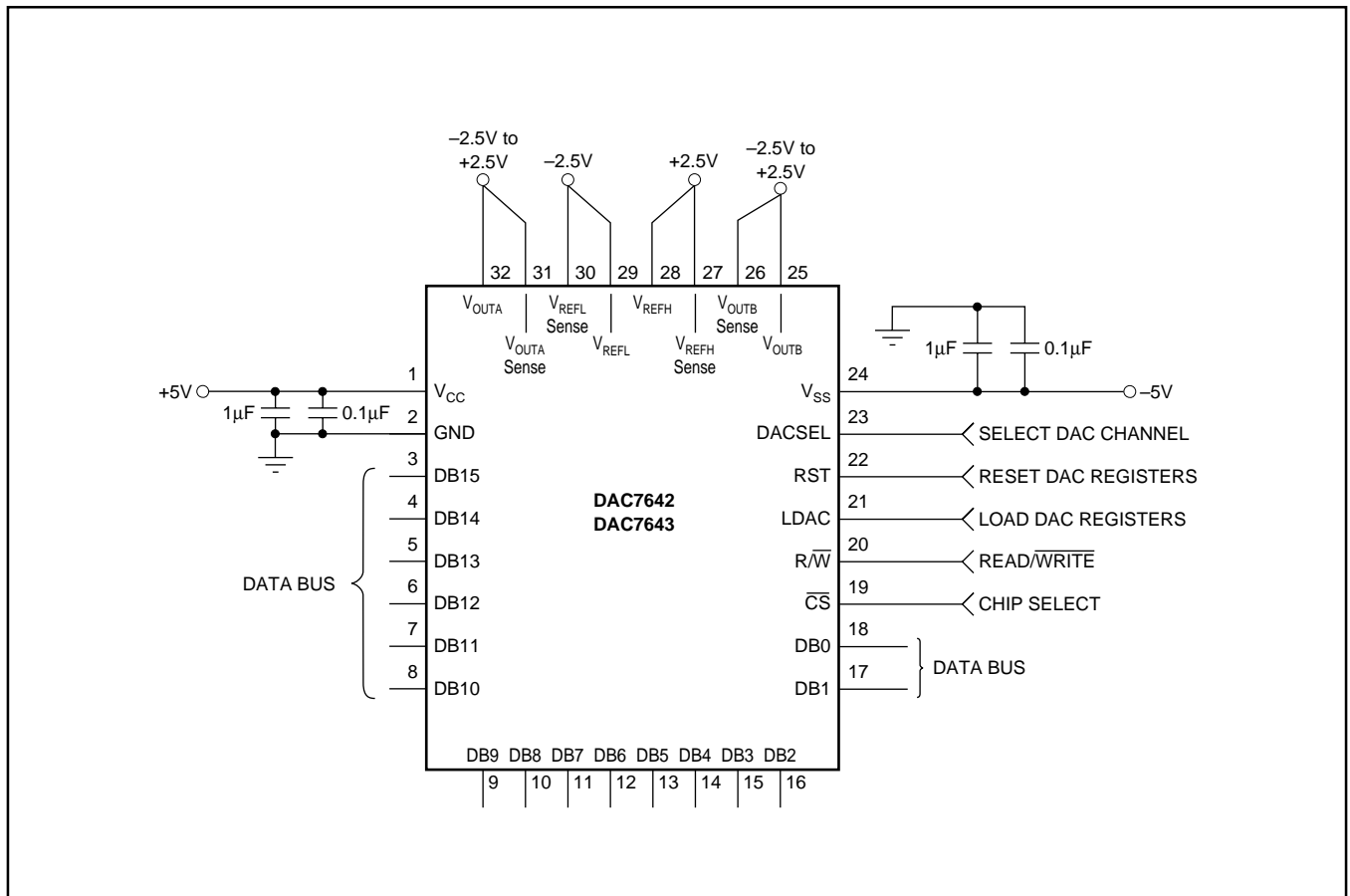

FIGURE 3. Basic Dual-Supply Operation of the DAC7642 and DAC7643.

## ANALOG OUTPUTS

When  $V_{SS} = -5V$  (dual-supply operation), the output amplifier can swing to within 2.25V of the supply rails over the  $-40^{\circ}C$  to  $+85^{\circ}C$  temperature range. When  $V_{SS} = 0V$  (single-supply operation), and with  $R_{LOAD}$  also connected to ground, the output can swing to ground. Care must also be taken when measuring the zero-scale error when  $V_{SS} = 0V$ . Since the DAC output cannot swing below ground, the output voltage may not change for the first few digital input codes (0000<sub>H</sub>, 0001<sub>H</sub>, 0002<sub>H</sub>, etc.) if the output amplifier has a negative offset. At the negative limit of  $-2mV$ , the first specified output starts at code 0040<sub>H</sub>.

Due to the high accuracy of these DACs, system design problems such as grounding and contact resistance become very important. A 16-bit converter with a 2.5V full-scale range has a 1LSB value of  $38\mu V$ . With a load current of 1mA, a series wiring and connector resistance of only  $40m\Omega$  ( $R_{W2}$ ) will cause a voltage drop of  $40\mu V$ , as shown in Figure 4. To understand what this means in terms of a system layout, the resistivity of a typical 1 ounce copper-clad printed circuit board is  $1/2 m\Omega$  per square. For a 1mA load, a 10 milli-inch wide printed circuit conductor 600 milli-inches long will result in a voltage drop of  $30\mu V$ .

The DAC7642 and DAC7643 offer a force and sense output configuration for the high open-loop gain output amplifiers. This feature allows the loop around the output amplifier to be closed at the load (shown in Figure 4), thus ensuring an accurate output voltage.

## REFERENCE INPUTS

The reference inputs,  $V_{REFL}$  and  $V_{REFH}$ , can be any voltage between  $V_{SS} + 2.5V$  and  $V_{CC} - 2.5V$  provided that  $V_{REFH}$  is at least 1.25V greater than  $V_{REFL}$ . The minimum output of each DAC is equal to  $V_{REFL}$  plus a small offset voltage (essentially, the offset of the output op amp). The maximum output is equal to  $V_{REFH}$  plus a similar offset voltage. Note

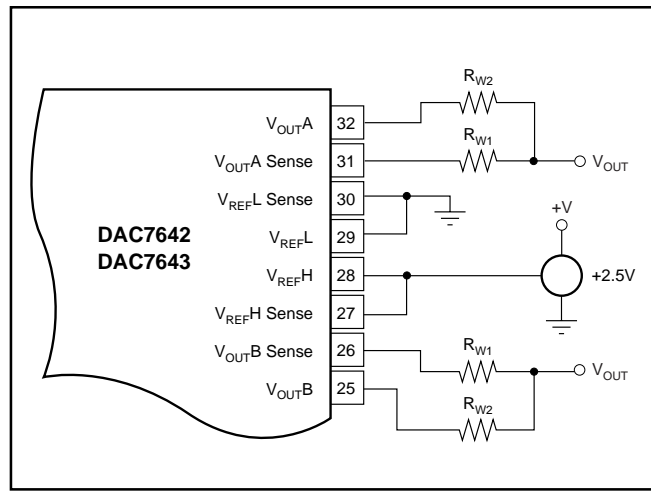

FIGURE 4. Analog Output Closed-Loop Configuration.  $R_W$  represents wiring resistances.

that  $V_{SS}$  (the negative power supply) must either be connected to ground or must be in the range of  $-4.75V$  to  $-5.25V$ . The voltage on  $V_{SS}$  sets several bias points within the converter. If  $V_{SS}$  is not in one of these two configurations, the bias values may be in error and proper operation of the device may be affected.

The current into the  $V_{REFH}$  input and out of  $V_{REFL}$  depends on the DAC output voltages and can vary from a few microamps to approximately 0.5mA. The reference input appears as a varying load to the reference. If the references applied can sink or source the required current, a reference buffer is not required. The DAC7642 and DAC7643 feature reference drive and sense connections such that the internal errors caused by the changing reference current and the circuit impedances can be minimized. Figures 5 through 13 show different reference configurations and the effect on the linearity and differential linearity.

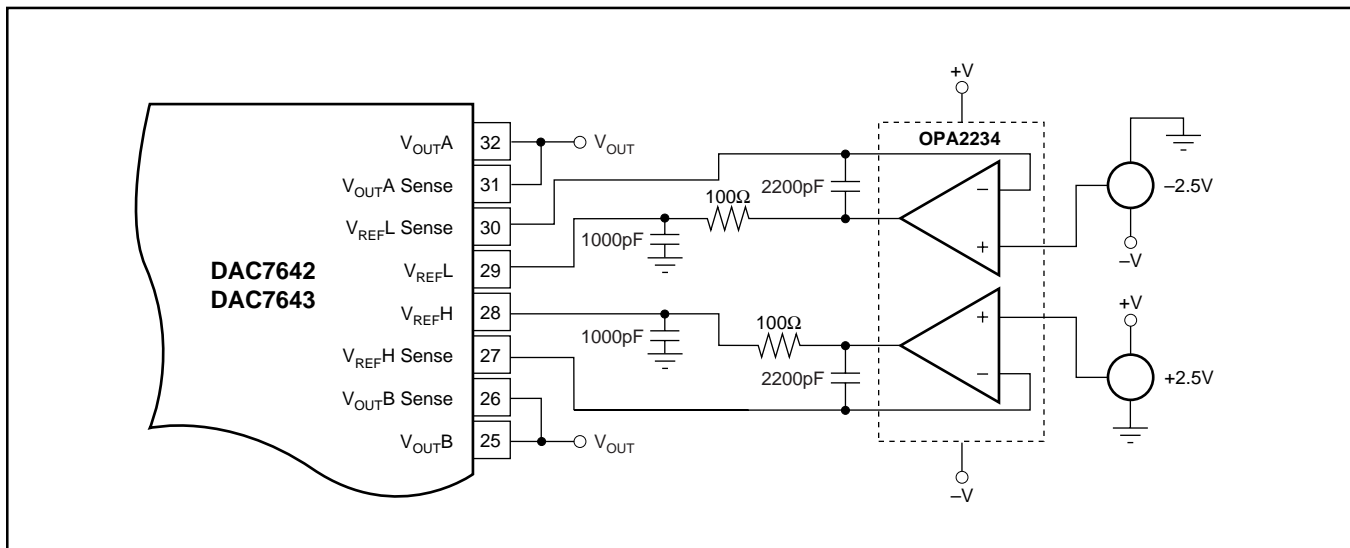

FIGURE 5. Dual Supply Configuration-Buffered References, Used for Dual-Supply Characteristic Curves.

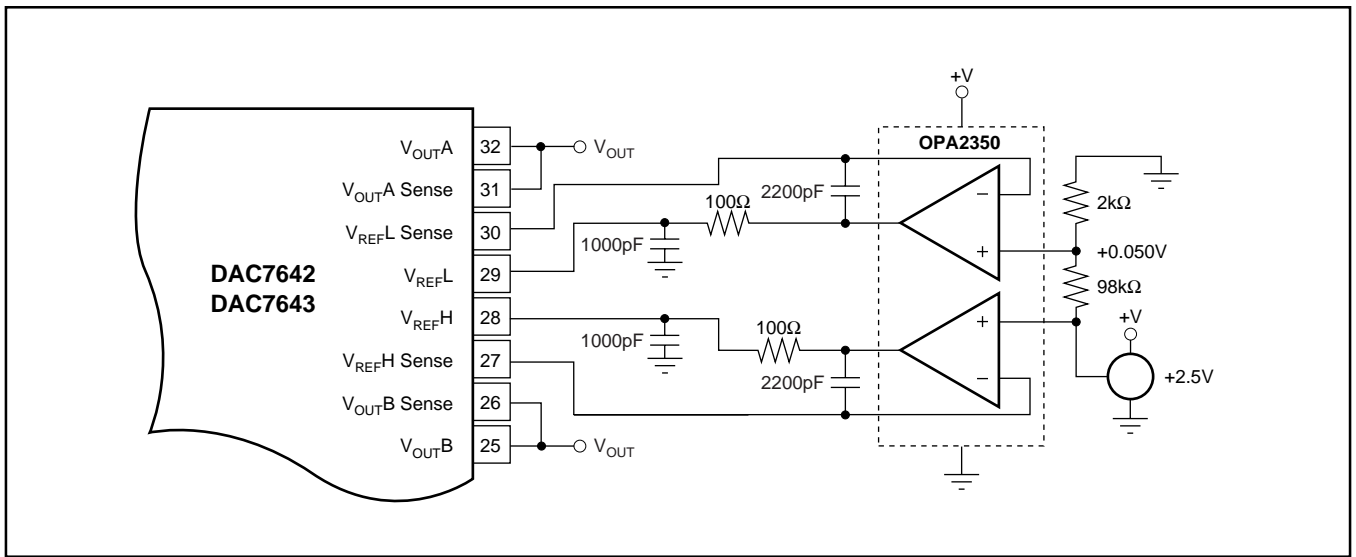

FIGURE 6. Single-Supply Buffered Reference with  $V_{REFL}$  of 50mV.

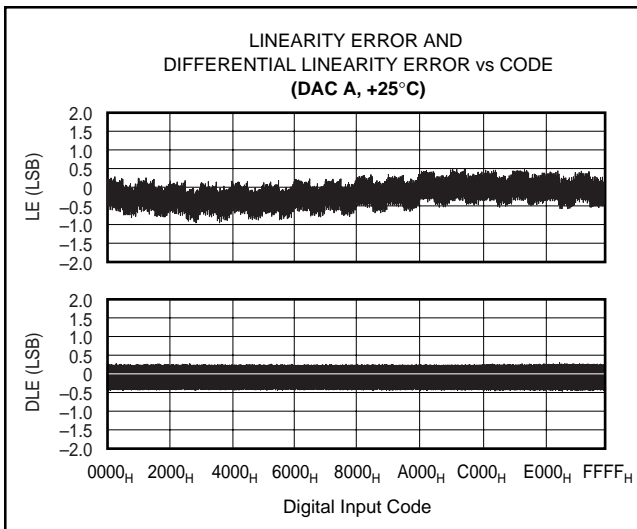

FIGURE 7. Integral Linearity and Differential Linearity Error Curves for Figure 6.

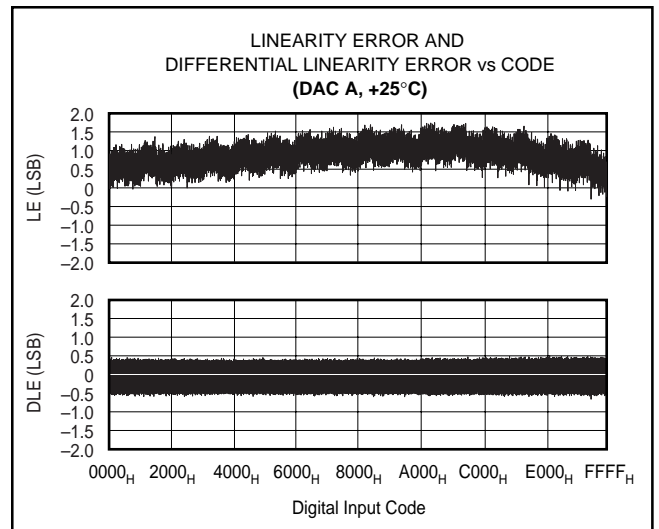

FIGURE 8. Integral Linearity and Differential Linearity Error Curves for Figure 9.

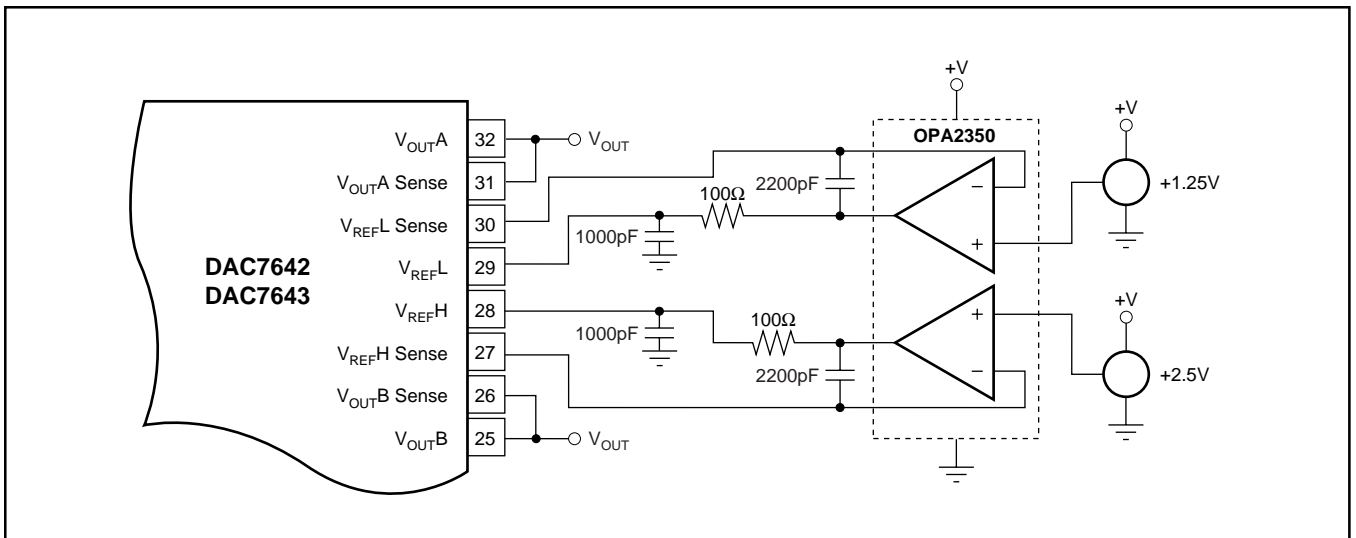

FIGURE 9. Single-Supply Buffered Reference with  $V_{REFL} = +1.25V$  and  $V_{REFH} = +2.5V$ .

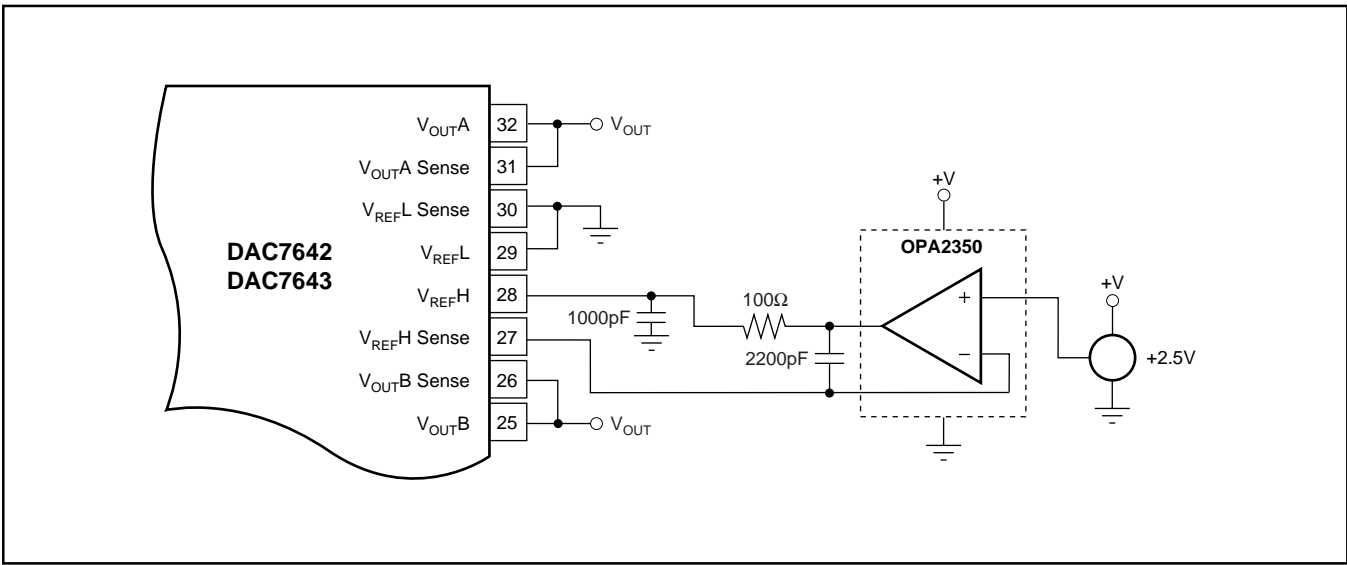

FIGURE 10. Single-Supply Buffered  $V_{REFH}$ .

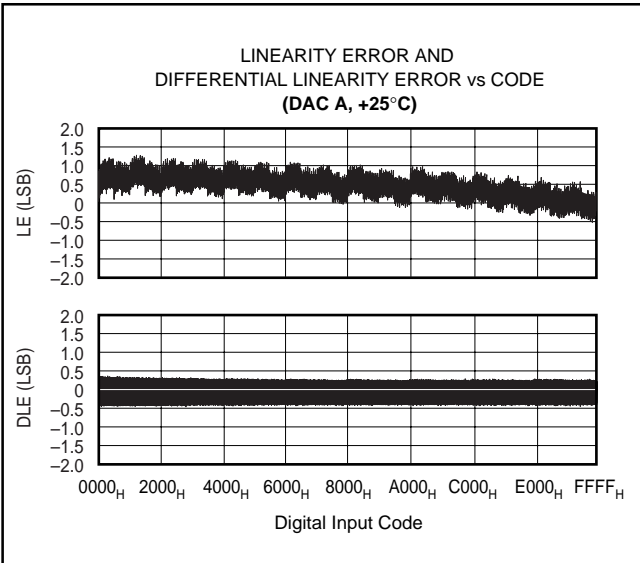

FIGURE 11. Linearity and Differential Linearity Error Curves for Figure 10.

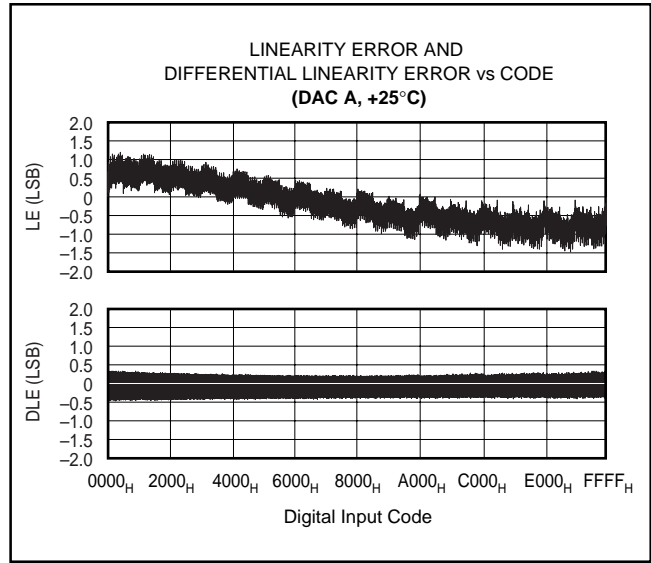

FIGURE 13. Linearity and Differential Linearity Error Curves for Figure 12.

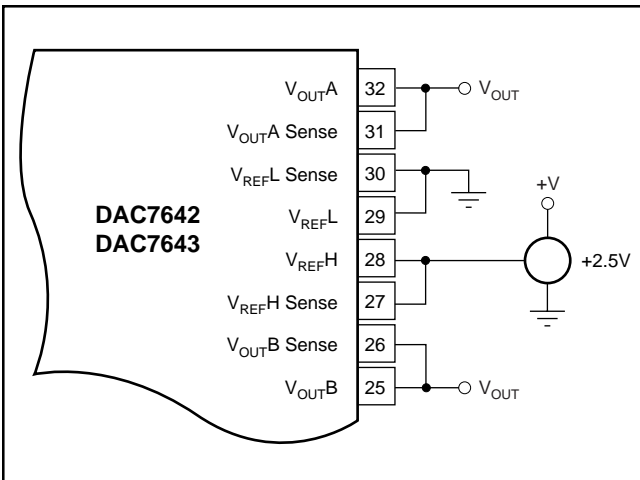

FIGURE 12. Low-Cost Single-Supply Configuration.

## DIGITAL INTERFACE

See Table I for the basic control logic of the DAC7642 and DAC7643. Note that each internal register is edge triggered and not level triggered. When the  $LOADDACS$  signal is transitioned from LOW to HIGH, the digital word existing in the input register is latched into the DAC register. The first set of registers (the input registers) are triggered via the  $DACSEL$ ,  $R/W$ , and  $CS$  inputs. Only one of these registers can be transparent at any given time.

The double-buffered architecture is designed mainly so each DAC input register can be written to at any time without affecting the DAC outputs. All DAC voltages are updated simultaneously by the rising edge of  $LOADDACS$ . It also allows multiple devices to be updated simultaneously by sharing the  $LOADDACS$  control from the host with each device.

DACSEL	R/W	CS	RST	LOADDACS	INPUT REGISTER	DAC REGISTER	MODE	DAC
L	L	L	L, H	X	Write	Hold	Write Input	A
H	L	L	L, H	X	Write	Hold	Write Input	B
L	H	L	L, H	X	Read	Hold	Read Input	A
H	H	L	L, H	X	Read	Hold	Read Input	B
X	X	H	L, H	↑	Hold	Write	Update	All
X	X	H	L, H	L, H	Hold	Hold	Hold	All
X	X	X	↑	L, H	Reset	Reset	Reset	All

TABLE I. DAC7642 and DAC7643 Logic Truth Table.

### DIGITAL TIMING

Figure 14 and Table II provide detailed timing for the digital interface of the DAC7642 and DAC7643.

$$V_{OUT} = V_{REFL} + \frac{(V_{REFH} - V_{REFL}) \cdot N}{65,536} \quad (1)$$

### DIGITAL INPUT CODING

The DAC7642 and DAC7643 input data is in Straight Binary format. The output voltage is given by Equation 1:

where N is the digital input code. This equation does not include the effects of offset (zero-scale) or gain (full-scale) errors.

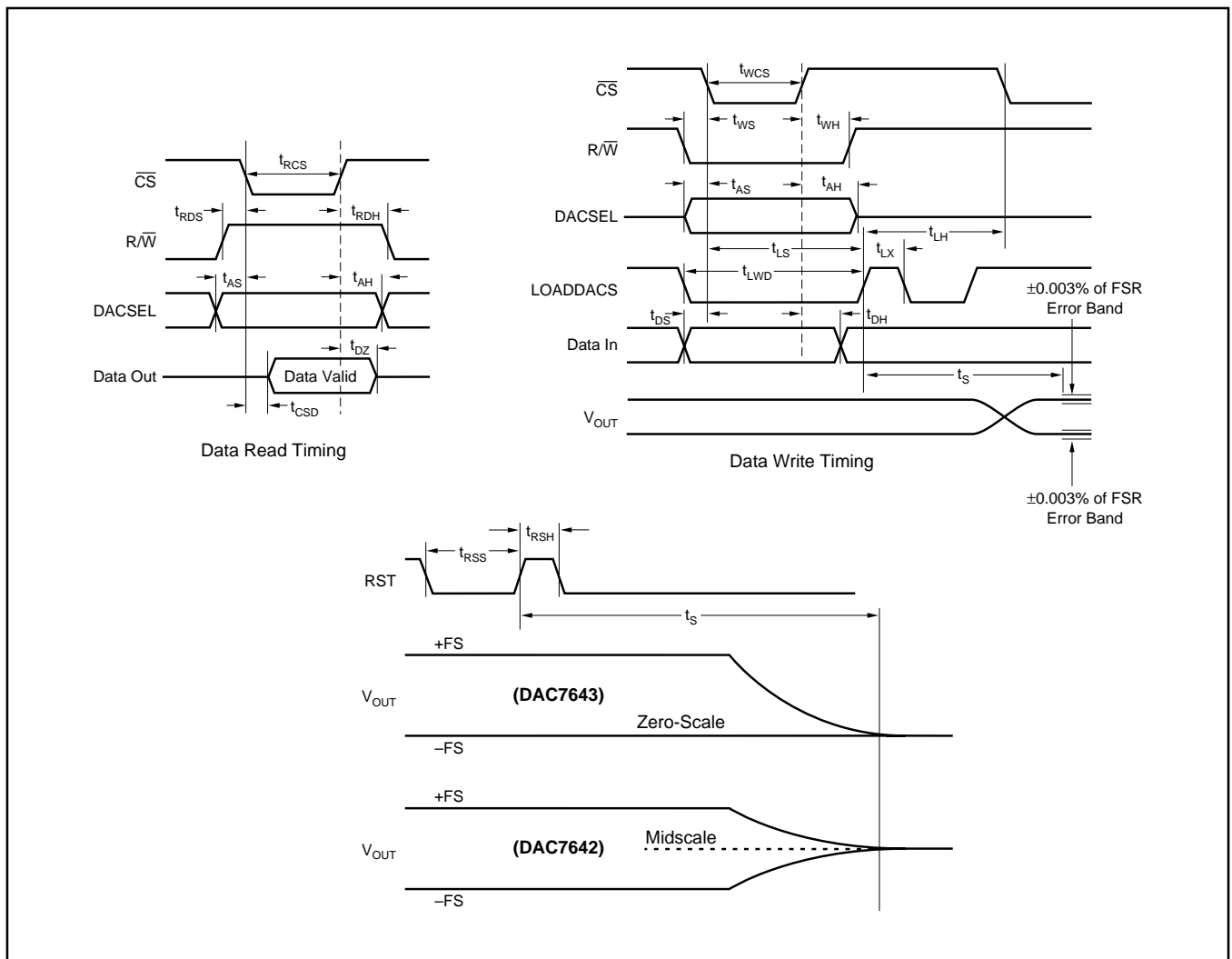

FIGURE 14. Digital Input and Output Timing.

SYMBOL	DESCRIPTION	MIN	TYP	MAX	UNITS
t <sub>RCS</sub>	$\overline{CS}$ LOW for Read	150			ns
t <sub>RDS</sub>	R/ $\overline{W}$ HIGH to $\overline{CS}$ LOW	10			ns
t <sub>RDH</sub>	R/ $\overline{W}$ HIGH after $\overline{CS}$ HIGH	10			ns
t <sub>DZ</sub>	$\overline{CS}$ HIGH to Data Bus in High Impedance	10		100	ns
t <sub>CSD</sub>	$\overline{CS}$ LOW to Data Bus Valid		100	150	ns
t <sub>WCS</sub>	$\overline{CS}$ LOW for Write	40			ns
t <sub>WS</sub>	R/ $\overline{W}$ LOW to $\overline{CS}$ LOW	0			ns
t <sub>WH</sub>	R/ $\overline{W}$ LOW after $\overline{CS}$ HIGH	10			ns
t <sub>AS</sub>	DACSEL Valid to $\overline{CS}$ LOW	0			ns
t <sub>AH</sub>	DACSEL Valid after $\overline{CS}$ HIGH	10			ns
t <sub>LS</sub>	$\overline{CS}$ LOW to LOADDACS HIGH	30			ns
t <sub>LH</sub>	$\overline{CS}$ LOW after LOADDACS HIGH	100			ns
t <sub>LX</sub>	LOADDACS HIGH	100			ns
t <sub>DS</sub>	Data Valid to $\overline{CS}$ LOW	0			ns
t <sub>DH</sub>	Data Valid after $\overline{CS}$ HIGH	10			ns
t <sub>LWD</sub>	LOADDACS LOW	100			ns
t <sub>RSS</sub>	RESET LOW	10			ns
t <sub>RSH</sub>	RESET HIGH	10			ns
t <sub>S</sub>	Settling Time			10	$\mu$ s

TABLE II. Timing Specifications ( $T_A = -40^\circ\text{C}$  to  $+85^\circ\text{C}$ ).

## DIGITALLY-PROGRAMMABLE CURRENT SOURCE

The DAC7642 and DAC7643 offer a unique set of features that allows a wide range of flexibility in designing applications circuits, such as programmable current sources. The DAC7642 and DAC7643 offer both a differential reference input, as well as an open-loop configuration around the output amplifier. The open-loop configuration around the output amplifier allows a transistor to be placed within the loop to implement a digitally-programmable, unidirectional current source. The availability of a differential reference also allows programmability for both the full-scale and zero-scale currents. The output current is calculated as:

$$I_{\text{OUT}} = \left( \left( \frac{V_{\text{REFH}} - V_{\text{REFL}}}{R_{\text{SENSE}}} \right) \cdot \left( \frac{N \text{ Value}}{65,536} \right) \right) + (V_{\text{REFL}} / R_{\text{SENSE}}) \quad (2)$$

Figure 15 shows a DAC7642 and DAC7643 in a 4-20mA current output configuration. The output current can be determined by Equation 3:

$$I_{\text{OUT}} = \left( \left( \frac{2.5\text{V} - 0.5\text{V}}{125\Omega} \right) \cdot \left( \frac{N \text{ Value}}{65,536} \right) \right) + \left( \frac{0.5\text{V}}{125\Omega} \right) \quad (3)$$

At full-scale, the output current is 16mA plus the 4mA for the zero current. At zero scale the output current is the offset current of 4mA ( $0.5\text{V}/125\Omega$ ).

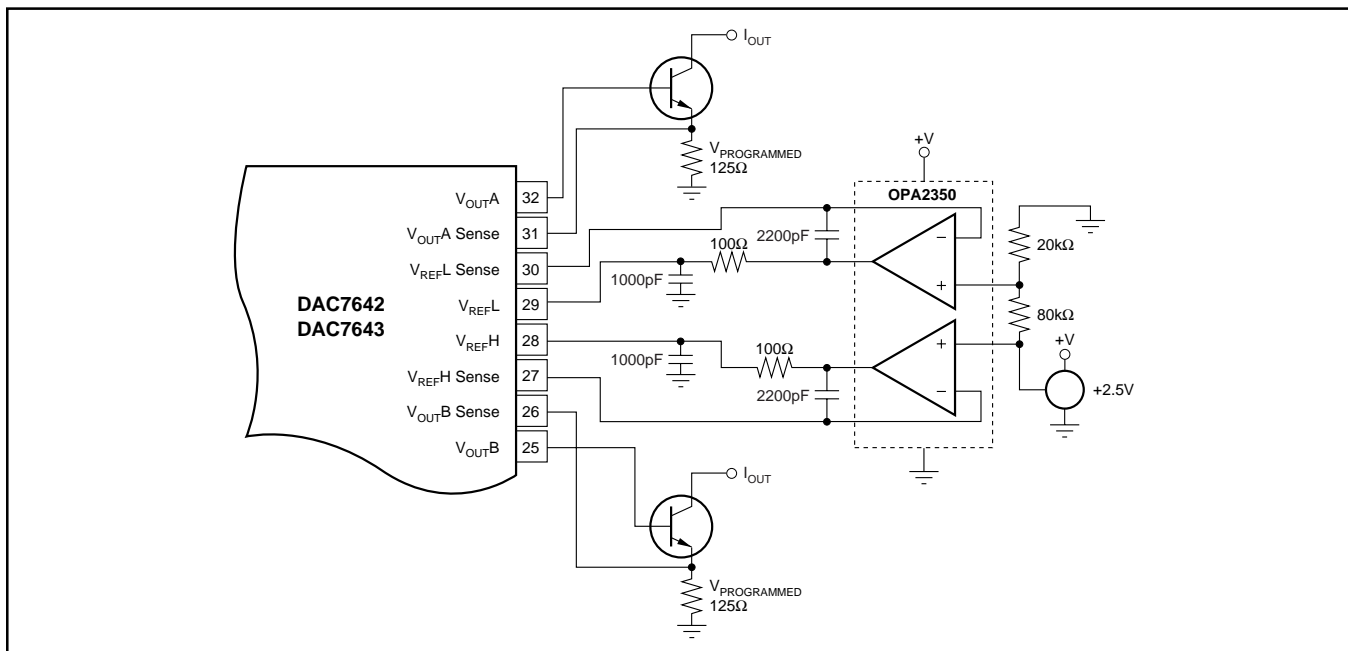
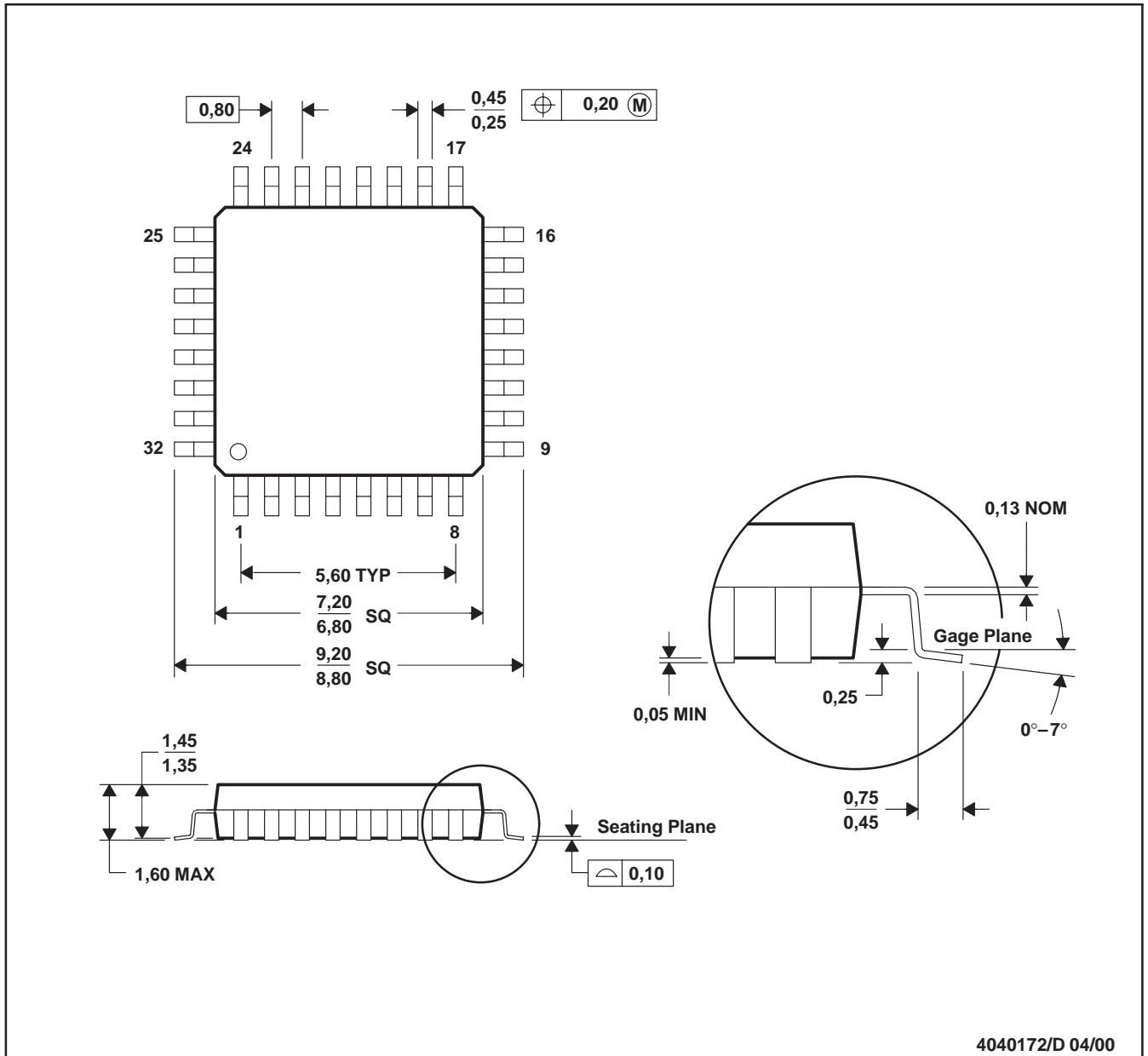

FIGURE 15. 4-20mA Digitally Controlled Current Source.



VF (S-PQFP-G32)

PLASTIC QUAD FLATPACK



- NOTES: A. All linear dimensions are in millimeters.  
 B. This drawing is subject to change without notice.

**PACKAGING INFORMATION**

Orderable Device	Status (1)	Package Type	Package Drawing	Pins	Package Qty	Eco Plan (2)	Lead finish/ Ball material (6)	MSL Peak Temp (3)	Op Temp (°C)	Device Marking (4/5)	Samples
DAC7642VFBT	ACTIVE	LQFP	VF	32	250	RoHS & Green	Call TI	Level-1-260C-UNLIM	-40 to 85	DAC7642 B	
DAC7642VFT	ACTIVE	LQFP	VF	32	250	RoHS & Green	Call TI	Level-1-260C-UNLIM	-40 to 85	DAC7642	

(1) The marketing status values are defined as follows:

**ACTIVE:** Product device recommended for new designs.

**LIFEBUY:** TI has announced that the device will be discontinued, and a lifetime-buy period is in effect.

**NRND:** Not recommended for new designs. Device is in production to support existing customers, but TI does not recommend using this part in a new design.

**PREVIEW:** Device has been announced but is not in production. Samples may or may not be available.

**OBSOLETE:** TI has discontinued the production of the device.

(2) **RoHS:** TI defines "RoHS" to mean semiconductor products that are compliant with the current EU RoHS requirements for all 10 RoHS substances, including the requirement that RoHS substance do not exceed 0.1% by weight in homogeneous materials. Where designed to be soldered at high temperatures, "RoHS" products are suitable for use in specified lead-free processes. TI may reference these types of products as "Pb-Free".

**RoHS Exempt:** TI defines "RoHS Exempt" to mean products that contain lead but are compliant with EU RoHS pursuant to a specific EU RoHS exemption.

**Green:** TI defines "Green" to mean the content of Chlorine (Cl) and Bromine (Br) based flame retardants meet JS709B low halogen requirements of <=1000ppm threshold. Antimony trioxide based flame retardants must also meet the <=1000ppm threshold requirement.

(3) MSL, Peak Temp. - The Moisture Sensitivity Level rating according to the JEDEC industry standard classifications, and peak solder temperature.

(4) There may be additional marking, which relates to the logo, the lot trace code information, or the environmental category on the device.

(5) Multiple Device Markings will be inside parentheses. Only one Device Marking contained in parentheses and separated by a "-" will appear on a device. If a line is indented then it is a continuation of the previous line and the two combined represent the entire Device Marking for that device.

(6) Lead finish/Ball material - Orderable Devices may have multiple material finish options. Finish options are separated by a vertical ruled line. Lead finish/Ball material values may wrap to two lines if the finish value exceeds the maximum column width.

**Important Information and Disclaimer:**The information provided on this page represents TI's knowledge and belief as of the date that it is provided. TI bases its knowledge and belief on information provided by third parties, and makes no representation or warranty as to the accuracy of such information. Efforts are underway to better integrate information from third parties. TI has taken and continues to take reasonable steps to provide representative and accurate information but may not have conducted destructive testing or chemical analysis on incoming materials and chemicals. TI and TI suppliers consider certain information to be proprietary, and thus CAS numbers and other limited information may not be available for release.

In no event shall TI's liability arising out of such information exceed the total purchase price of the TI part(s) at issue in this document sold by TI to Customer on an annual basis.





# PACKAGE OUTLINE

## VF0032A

### LQFP - 1.6 mm max height

PLASTIC QUAD FLATPACK

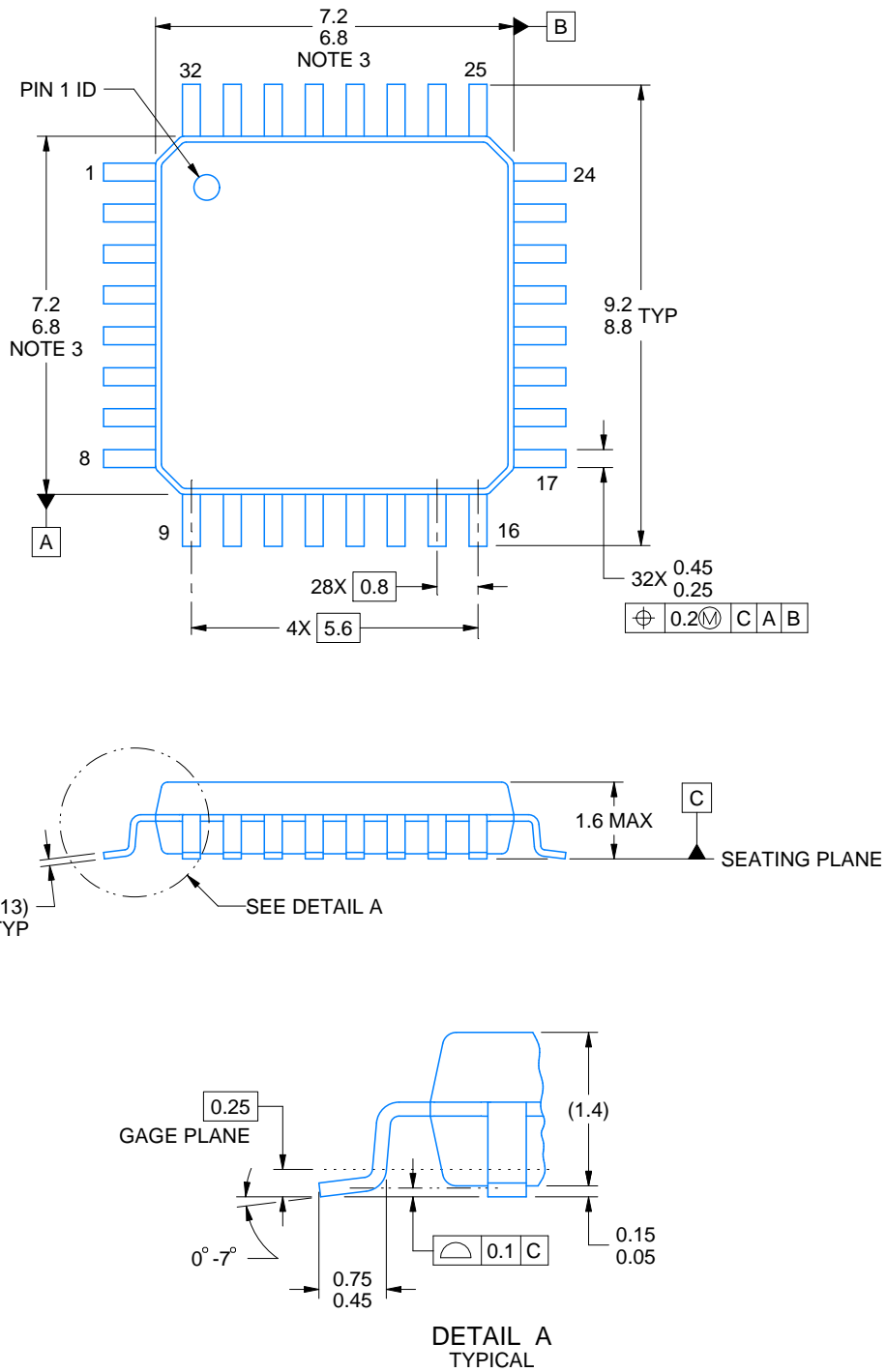

4219769/A 04/2019

#### NOTES:

PowerPAD is a trademark of Texas Instruments.

1. All linear dimensions are in millimeters. Any dimensions in parenthesis are for reference only. Dimensioning and tolerancing per ASME Y14.5M.
2. This drawing is subject to change without notice.
3. This dimension does not include mold flash, protrusions, or gate burrs.
4. Reference JEDEC registration MS-026.



# EXAMPLE STENCIL DESIGN

VF0032A

LQFP - 1.6 mm max height

PLASTIC QUAD FLATPACK

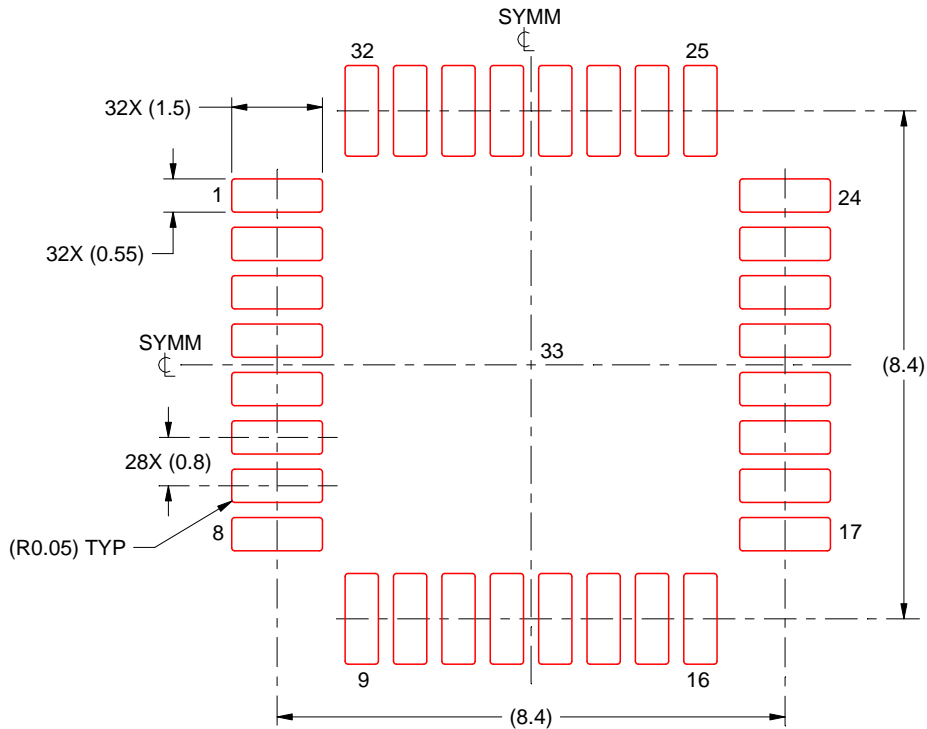

SOLDER PASTE EXAMPLE  
SCALE:8X

4219769/A 04/2019

NOTES: (continued)

7. Laser cutting apertures with trapezoidal walls and rounded corners may offer better paste release. IPC-7525 may have alternate design recommendations.
8. Board assembly site may have different recommendations for stencil design.

## IMPORTANT NOTICE AND DISCLAIMER

TI PROVIDES TECHNICAL AND RELIABILITY DATA (INCLUDING DATA SHEETS), DESIGN RESOURCES (INCLUDING REFERENCE DESIGNS), APPLICATION OR OTHER DESIGN ADVICE, WEB TOOLS, SAFETY INFORMATION, AND OTHER RESOURCES "AS IS" AND WITH ALL FAULTS, AND DISCLAIMS ALL WARRANTIES, EXPRESS AND IMPLIED, INCLUDING WITHOUT LIMITATION ANY IMPLIED WARRANTIES OF MERCHANTABILITY, FITNESS FOR A PARTICULAR PURPOSE OR NON-INFRINGEMENT OF THIRD PARTY INTELLECTUAL PROPERTY RIGHTS.

These resources are intended for skilled developers designing with TI products. You are solely responsible for (1) selecting the appropriate TI products for your application, (2) designing, validating and testing your application, and (3) ensuring your application meets applicable standards, and any other safety, security, regulatory or other requirements.

These resources are subject to change without notice. TI grants you permission to use these resources only for development of an application that uses the TI products described in the resource. Other reproduction and display of these resources is prohibited. No license is granted to any other TI intellectual property right or to any third party intellectual property right. TI disclaims responsibility for, and you will fully indemnify TI and its representatives against, any claims, damages, costs, losses, and liabilities arising out of your use of these resources.

TI's products are provided subject to [TI's Terms of Sale](#) or other applicable terms available either on [ti.com](http://ti.com) or provided in conjunction with such TI products. TI's provision of these resources does not expand or otherwise alter TI's applicable warranties or warranty disclaimers for TI products.

TI objects to and rejects any additional or different terms you may have proposed.

Mailing Address: Texas Instruments, Post Office Box 655303, Dallas, Texas 75265  
Copyright © 2021, Texas Instruments Incorporated

## Looking for pricing, stock, or lifecycle information?

Click below to explore more details on WIN SOURCE:

 [View DAC7642VFTG4](#) on WIN SOURCE

 [Texas Instruments](#) Information

## Optimize Your Supply Chain with WIN SOURCE Solutions

-  Global Sourcing Solution
-  Obsolete Management
-  Cost Control Management
-  Shortage Management
-  Alternative Solution
-  Excess Inventory Management