



**THE DATASHEET OF
BD9584F-E2**



STRUCTURE SILICON MONOLITHIC INTEGRATED CIRCUIT

FUNCTION EARTH LEAKAGE CURRENT DETECTOR

PRODUCT SERIES BD9584F

- FEATURES
- Anti-lighting-surge function
The second times or one and half times of the input signal from the current mutual Inductance(GT) triggers the SCR.
 - Low current dissipation [In stand-by condition:250 μ A(Typ.)]
 - High stabilities design.
 - Adopt the circuits that are not affected by fluctuations of supply voltage/ambient temperature.

○ABSOLUTE MAXIMUM RATINGS (Ta=25[°C])

Characteristics	Symbol	Rating	Unit
Supply Current	Is	12.5	mA
TRC1/TRC2/NR/OS terminal voltage	V _{TRC1/TRC/NR/OS}	8	V
Power Dissipation	PD	0.68(*1)	W
Storage Temperature Range	Tstg	-55~+150	°C

• This IC is not designed for protection against radioactive rays.
(*1) To use at temperature above Ta=25[°C] reduce 5.5[mw]/[°C].
Mounted on a glass epoxy PCB (70[mm] × 70[mm] × 1.6[mm])

○RECOMMENDED OPERATING CONDITION

Parameter	Symbol	Rating	Unit
Supply Voltage Range	Vs	8 ~ 20	V
Operating Temperature Range	Topr	-20~+90	°C

(Set the power supply voltage taking allowable dissipation into considering)

Application example

• ROHM cannot provide adequate confirmation of patents.
• The product described in this specification is designed to be used with ordinary electronic equipment or devices (such as audio-visual equipment, office-automation equipment, communications devices, electrical appliances, and electronic toys).
Should you intend to use this product with equipment or devices which require an extremely high level of reliability and the malfunction of which would directly endanger human life (such as medical instruments, transportation equipment, aerospace machinery, nuclear-reactor controllers, fuel controllers and other safety devices), please be sure to consult with our sales representative in advance.
• ROHM assumes no responsibility for the use of any circuits described herein, conveys no license under any patent or other right.

DESIGN	CHECK	APPROVAL	DATE AUG. /5/2010	SPECIFICATION No 暫定仕様
			REV. 1.0	ROHM Co.,Ltd.

○ELECTRICAL CHARACTERISTICS (Unless otherwise specified Vs=12V, Ta=25°C)

Characteristics	Symbol	Guaranteed Limit			Unit	Condition
		Min.	Typ.	Max.		
Supply Current (Stanby)	IS	-	250	340	μA	V _R -V _{IN} =0
Total AC Input Voltage of Leakage Detection	VT	6.4 -4.5	9.2 -6.5	12 -8.5	mV (mV _{rms})	-20~90°C, 50Hz/60Hz CTR _C =0.047 μF
Os-Pin" H" Output Voltage	Vos	3	-	-	V	V _S =8V~32V
Os-Pin" L" Output Voltage		-	-	200	mV	OS-pin is not connected.
Os Output Current	Ios	250	-	-	μA	Leakage detected
IN-Pin Input Bias Current	IIN	-	100	-	nA	V _R =V _{IN}
VR-Pin Output Voltage	V _R	2.1	2.4	2.7	V	V _S =8V~32V
NR-Pin Output Current	E _{IoH} (RS)	6.9	9.9	12.9	μA	Vos=0V
NR Threshold Voltage	V _{TH} (RS)	2.1	2.4	2.7	V	
TW3 pulse Width	ETWS(RS)	53.7	80	129.1	ms	C=0.33 μF
TRC1-pin output current	E _{IoH1}	35.9	51.3	66.7	μA	V _{TRC} =0V
TRC1 threshold voltage	V _{TH1}	2.1	2.4	2.7	V	
TW1 pulse width	ETWS1	1.48	2.2	3.53	ms	C=0.047 μF
TRC2-pin output current	E _{IoH2}	35.9	51.3	66.7	μA	V _O =0V
TRC2 threshold voltage	V _{TH2}	2.1	2.4	2.7	V	
TW2 pulse width	ETWS2	1.48	2.2	3.53	ms	C=0.047 μF

○BLOCK DIAGRAM

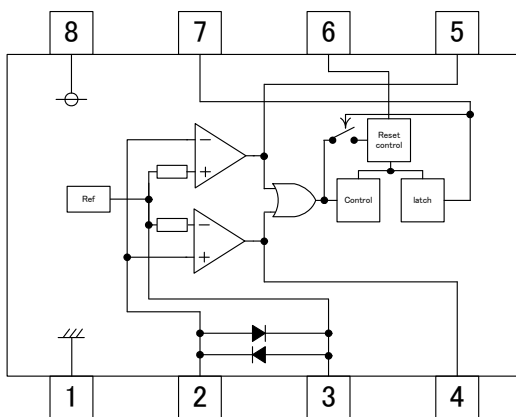

○PIN DESCRIPTIONS

Pin No.	Pin Name	
1	GND	Ground
2	IN	input terminal
3	V _R	input terminal (reference voltage)
4	TRC1	Integral capacitor connection for leakage signal voltage detection
5	TRC2	Integral capacitor connection for inverse leakage signal voltage detection
6	NR	Noise attenuation capacitor connection
7	Os	Output terminal
8	V _S	Supply Voltage Input terminal

○PACKAGE

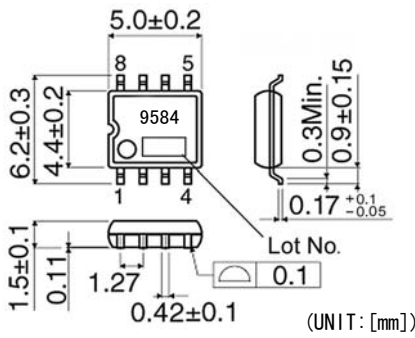

[Fig. -1]

○APPLICATION

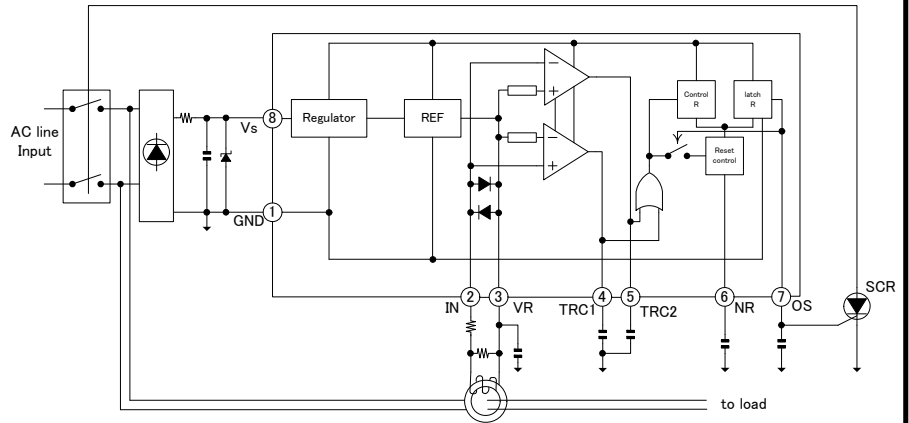

○FUNCTION DESCRIPTION

Earth leakage current detector has five modules: the difference amplifier, the latch, the reference, the voltage regulator and the reset control circuit (it is a timer indeed). This IC is connected to the sub-coils of the zero current mutual inductance (ZCT). The ZCT detects the leakage current which flows into the two inputs of the difference amplifier. Then the leakage current signal is amplified and integrated through two external capacitors. When the voltage of one of the two external capacitors exceeds the reference voltage, the counter counts once, and at the same time, the reset control circuit discharge once. When the voltage of the one of the two external capacitors exceeds the reference voltage another times, the counter counts twice, and at the same time, the latch triggers. This trigger sends out a trigger signal to the external SCR, and disconnects the reset control circuit from the OR gate. This makes the reset control circuit to reset the counter and the latch after the programmed time.

[Fig. 1] The one and half times trigger

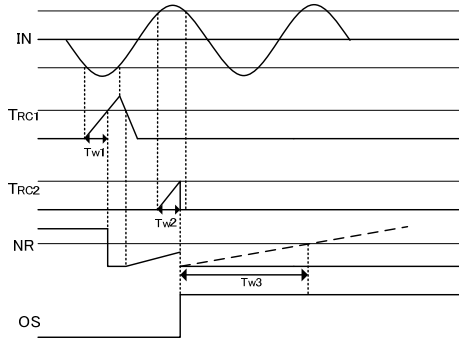

[Fig. 2] The second times negative trigger

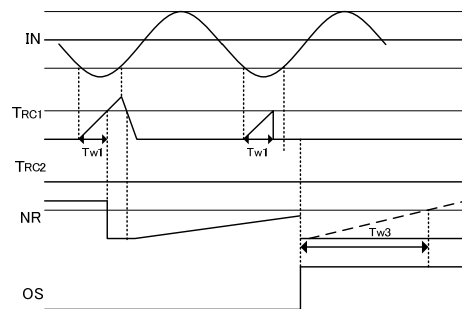

[Fig. 3] The second times positive trigger

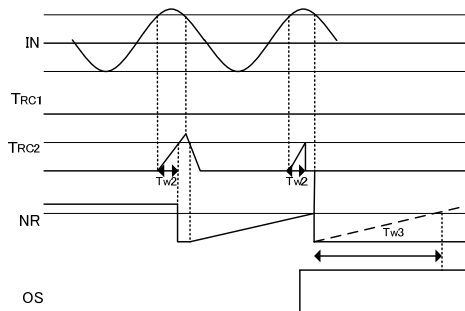

[Fig. 4] Not trigger

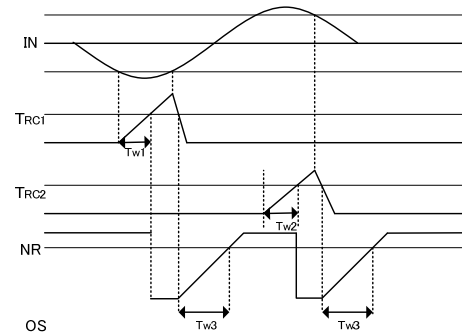

○NOTICE

①Absolute maximum ratings

Absolute maximum ratings are the values which indicate the limits, within which the given voltage range can be safely charged to the terminal.
However, it does not guarantee the circuit operation.

②Power dissipation(Pd)

If the IC is used under excessive power dissipation. An increase in the chip temperature will cause deterioration of the radical characteristics of IC.
For example, reduction of current capability. Take consideration of the effective power dissipation and thermal design with a sufficient margin. Pd is reference to the provided power dissipation curve.

③Using under strong electromagnetic field

Be careful when using the IC under strong electromagnetic field because it may malfunction.

④Usage of IC

When stress is applied to the IC through warp of the printed circuit board,
The characteristics may fluctuate due to the piezo effect.
Be careful of the warp of the printed circuit board.

⑤Testing IC on the set board



When testing IC on the set board, in cases where the capacitor is connected to the low impedance, make sure to discharge per fabrication because there is a possibility that IC may be damaged by stress.

When removing IC from the set board, it is essential to cut supply voltage.

As a countermeasure against the static electricity, observe proper grounding during fabrication process and take due care when carrying and storage it.

Looking for pricing, stock, or lifecycle information?

Click below to explore more details on WIN SOURCE:

-  [View BD9584F-E2 on WIN SOURCE](#)
-  [Rohm Semiconductor](#) Information

Optimize Your Supply Chain with WIN SOURCE Solutions

-  Global Sourcing Solution
-  Obsolete Management
-  Cost Control Management
-  Shortage Management
-  Alternative Solution
-  Excess Inventory Management