

SN65HVD2x Extended Common-Mode RS-485 Transceivers

1 Features

- Common-mode voltage range (–20 V to 25 V) more than doubles TIA/EIA-485 requirement
- Receiver equalization extends cable length, signaling rate (SN65HVD2[3,4])
- Reduced unit-load for up to 256 nodes
- Bus I/O protection to over 16-kV HBM
- Failsafe receiver for open-circuit, short-circuit, and idle-bus conditions
- Low standby supply current 1 μ A (maximum)
- More than 100 mV receiver hysteresis

2 Applications

- Long cable solutions
 - [Factory automation](#)
 - [Security networks](#)
 - [Building HVAC](#)
- Severe electrical environments
 - [Electrical power inverters](#)
 - [Industrial drives](#)
 - [Avionics](#)

3 Description

The transceivers in the SN65HVD2x family offer performance far exceeding typical RS-485 devices. In addition to meeting all requirements of the TIA/EIA-485-A standard. The SN65HVD2x family operates over an extended range of common-mode voltages and has features such as high ESD protection, wide receiver hysteresis, and failsafe operation. This family of devices is designed for long-cable networks, and other applications where the environment is too harsh for ordinary transceivers.

These devices are designed for bidirectional data transmission on multipoint twisted-pair cables. Example applications are digital motor controllers, remote sensors and terminals, industrial process control, security stations, and environmental control systems.

These devices combine a 3-state differential driver and a differential receiver that operate from a single 5-V power supply. The driver differential outputs and the receiver differential inputs are connected internally to form a differential bus port that offers minimum loading to the bus. This port features an extended common-mode voltage range, making the device suitable for multipoint applications over long cable runs.

Package Information

PART NUMBER	PACKAGE ⁽¹⁾	BODY SIZE (NOM)
SN65HVD2x	SOIC (8)	4.90 mm × 3.91 mm
	PDIP (8)	9.81 mm × 6.35 mm

(1) For all available packages, see the orderable addendum at the end of the data sheet.

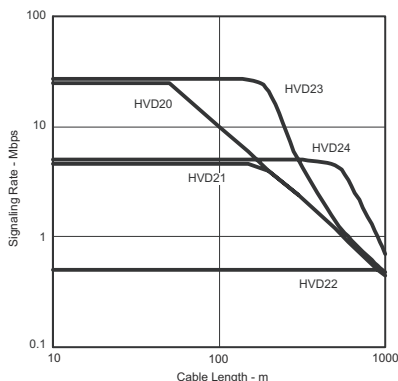

SN65HVD2x Application Space

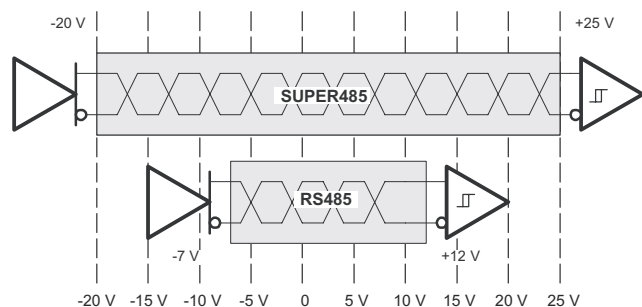

SN65HVD2x Devices Operate Over a Wider Common-Mode Voltage Range



Table of Contents

1 Features	1	10 Detailed Description	18
2 Applications	1	10.1 Overview.....	18
3 Description	1	10.2 Functional Block Diagram.....	18
4 Revision History	2	10.3 Feature Description.....	18
5 Description (continued)	4	10.4 Device Functional Modes.....	20
6 Device Comparison	4	11 Application and Implementation	23
7 Pin Configuration and Functions	5	11.1 Application Information.....	23
8 Specifications	6	11.2 Typical Application.....	23
8.1 Absolute Maximum Ratings.....	6	12 Power Supply Recommendations	25
8.2 ESD Ratings.....	6	13 Layout	26
8.3 Recommended Operating Conditions.....	6	13.1 Layout Guidelines.....	26
8.4 Thermal Information.....	8	13.2 Layout Example.....	26
8.5 Driver Electrical Characteristics.....	8	14 Device and Documentation Support	27
8.6 Receiver Electrical Characteristics.....	9	14.1 Receiving Notification of Documentation Updates..	27
8.7 Driver Switching Characteristics.....	9	14.2 Support Resources.....	27
8.8 Receiver Switching Characteristics.....	10	14.3 Trademarks.....	27
8.9 Receiver Equalization Characteristics.....	10	14.4 Electrostatic Discharge Caution.....	27
8.10 Power Dissipation.....	11	14.5 Glossary.....	27
8.11 Typical Characteristics.....	12	15 Mechanical, Packaging, and Orderable Information	27
9 Parameter Measurement Information	14		

4 Revision History

NOTE: Page numbers for previous revisions may differ from page numbers in the current version.

Changes from Revision F (November 2016) to Revision G (August 2022)	Page
• Deleted the Available Options table.....	4
• Changed the D (SOIC) values in the <i>Thermal Information</i>	8
Changes from Revision E (May 2010) to Revision F (November 2016)	Page
• Added <i>ESD Ratings</i> table, <i>Feature Description</i> section, <i>Device Functional Modes</i> , <i>Application and Implementation</i> section, <i>Power Supply Recommendations</i> section, <i>Layout</i> section, <i>Device and Documentation Support</i> section, and <i>Mechanical, Packaging, and Orderable Information</i> section.....	1
• Deleted <i>Ordering Information</i> table; see POA at the end of the data sheet.....	1
• Added maximum temperature value (150°C) to the Storage temperate, T _{stg} parameter.....	6
Changes from Revision D (April 2005) to Revision E (May 2010)	Page
• Replaced the Dissipation Rating table with the <i>Thermal Information</i> table.....	8
• Changed I _O - Added test condition and values per device number (<i>Driver Electrical Characteristics</i> table).....	8
• Changed the Thermal Characteristics table to <i>Power Dissipation</i> table.....	11
• Added the TEST MODE DRIVER DISABLE section.....	21
Changes from Revision C (September 2003) to Revision D (April 2005)	Page
• Added Receiver output current, I _O to the <i>Absolute Maximum Ratings</i> table.....	6
Changes from Revision B (June 2003) to Revision C (September 2003)	Page
• Added the <i>Thermal Information</i> table.....	8
• Added the Theory of Operation section.....	18
• Added the <i>Noise Considerations for Equalized Receivers</i> section.....	23

Changes from Revision A (March 2003) to Revision B (June 2003) Page

- Added V_{IK} Typical Value of 0.75 V (*Driver Electrical Characteristics* table).....8
- Deleted $V_{IT(F+)} - V_{CM} = -20\text{ V to } 25\text{ V}$ Minimum value (*Receiver Electrical Characteristics* table).....9
- Added the *Receiver Equalization Characteristics* table..... 10
- Added [Figure 8-6](#), [Figure 8-7](#), and [Figure 8-8](#) to the *Typical Characteristics* 12
- Changed A Input circuit in the *Equivalent Input and Output Schematic Diagrams*22
- Changed the Integrated Receiver Equalization Using the SN65HVD23 section..... 24

Changes from Revision * (December 2002) to Revision A (March 2003) Page

- Changed t_{PZH} , t_{PHZ} , t_{PZL} , and t_{PLZ} - From a maximum value of 120 to include typical and maximum values for each entry (*Receiver Switching Characteristics* table)..... 10
- Changed t_{PZH} , t_{PHZ} , t_{PZL} , and t_{PLZ} - From a maximum value of 120 to include typical and maximum values for each entry (*Receiver Switching Characteristics* table)..... 10

5 Description (continued)

The SN65HVD20 device provides high signaling rate (up to 25 Mbps) for interconnecting networks of up to 64 nodes.

The SN65HVD21 device allows up to 256 connected nodes at moderate data rates (up to 5 Mbps). The driver output slew rate is controlled to provide reliable switching with shaped transitions which reduce high-frequency noise emissions.

The SN65HVD22 device has controlled driver output slew rate for low radiated noise in emission-sensitive applications and for improved signal quality with long stubs. Up to 256 SN65HVD22 nodes can be connected at signaling rates up to 500 kbps.

The SN65HVD23 device implements receiver equalization technology for improved jitter performance on differential bus applications with data rates up to 25 Mbps at cable lengths up to 160 meters.

The SN65HVD24 device implements receiver equalization technology for improved jitter performance on differential bus applications with data rates from 1 Mbps to 10 Mbps at cable lengths up to 1000 meters.

The receivers include a failsafe circuit that provides a high-level output within 250 microseconds after loss of the input signal. The most common causes of signal loss are disconnected cables, shorted lines, or the absence of any active transmitters on the bus. This feature prevents noise from being received as valid data under these fault conditions. This feature may be used for Wired-OR bus signaling.

The SN65HVD2x devices are characterized for operation temperatures from –40°C to 85°C.

6 Device Comparison

Table 6-1. Product Selection Guide

PART NUMBERS	CABLE LENGTH AND SIGNALING RATE ⁽¹⁾	NODES	MARKING
SN65HVD20	Up to 50 m at 25 Mbps	Up to 64	D: VP20, P: 65HVD20
SN65HVD21	Up to 150 m at 5 Mbps (with slew rate limit)	Up to 256	D: VP21, P: 65HVD21
SN65HVD22	Up to 1200 m at 500 kbps (with slew rate limit)	Up to 256	D: VP22, P: 65HVD22
SN65HVD23	Up to 160 m at 25 Mbps (with receiver equalization)	Up to 64	D: VP23, P: 65HVD23
SN65HVD24	Up to 500 m at 3 Mbps (with receiver equalization)	Up to 256	D: VP24, P: 65HVD24

(1) Distance and signaling rate predictions based upon Belden 3105A cable and 15% eye pattern jitter.

7 Pin Configuration and Functions

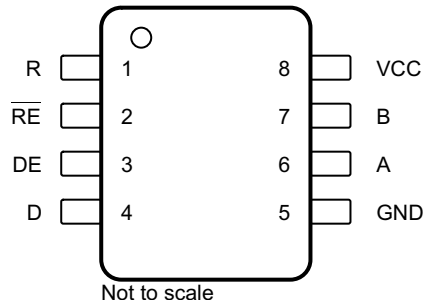

Figure 7-1. D or P Package, 8-Pin SOIC or PDIP (Top View)

Table 7-1. Pin Functions

PIN		I/O	DESCRIPTION
NAME	NO.		
A	6	Bus input and output	Driver output or receiver input (complementary to B)
B	7	Bus input and output	Driver output or receiver input (complementary to A)
D	4	Digital input	Driver data input
DE	3	Digital input	Driver enable, active high
GND	5	Reference potential	Local device ground
R	1	Digital output	Receive data output
RE	2	Digital input	Receiver enable, active low
VCC	8	Supply	4.5-V to 5.5-V supply

8 Specifications

8.1 Absolute Maximum Ratings

over operating free-air temperature range (unless otherwise noted) ⁽¹⁾

			MIN	MAX	UNIT
Supply voltage ⁽²⁾			-0.5	7	V
Voltage at any bus I/O terminal			-27	27	V
Voltage input, transient pulse	A, B	(through 100 Ω, see Figure 9-16)	-60	60	V
Voltage input	D, DE, RE		-0.5	V _{CC} + 0.5	V
Receiver output current			-10	10	mA
Continuous total power dissipation			See Power Dissipation Ratings		
Junction temperature, T _J				150	°C
Storage temperature, T _{stg}				150	°C

- (1) Stresses beyond those listed under *Absolute Maximum Ratings* may cause permanent damage to the device. These are stress ratings only, which do not imply functional operation of the device at these or any other conditions beyond those indicated under *Recommended Operating Conditions*. Exposure to absolute-maximum-rated conditions for extended periods may affect device reliability.
- (2) All voltage values, except differential I/O bus voltages, are with respect to network ground terminal.

8.2 ESD Ratings

			VALUE	UNIT	
V _(ESD)	Electrostatic discharge	Human-body model (HBM), per ANSI/ESDA/ JEDEC JS-001 ⁽¹⁾	All pins except 5, 6, and 7	±5000	V
			Pins 5, 6, and 7	±16000	
		Charged-device model (CDM), per JEDEC specification JESD22-C101 ⁽²⁾		±1500	
		Machine Model (MM) ⁽³⁾		±200	

- (1) Tested in accordance with JEDEC Standard 22, Test Method A114-A.
- (2) Tested in accordance with JEDEC Standard 22, Test Method C101.
- (3) Tested in accordance with JEDEC Standard 22, Test Method A115-A

8.3 Recommended Operating Conditions

			MIN	NOM	MAX	UNIT
V _{CC}	Supply voltage		4.5	5	5.5	V
	Voltage at any bus I/O terminal	A, B	-20		25	V
V _{IH}	High-level input voltage	D, DE, RE	2		V _{CC}	V
V _{IL}	Low-level input voltage		0		0.8	V
V _{ID}	Differential input voltage		-25		25	V
	Output current	Driver	-110		110	mA
		Receiver	-8		8	

8.3 Recommended Operating Conditions (continued)

			MIN	NOM	MAX	UNIT
I_{CC}	Supply current	Driver enabled (DE at V_{CC}), Receiver enabled (RE at 0 V), No load, $V_I = 0\text{ V or }V_{CC}$	SN65HVD20	6	9	mA
			SN65HVD21	8	12	
			SN65HVD22	6	9	
			SN65HVD23	7	11	
			SN65HVD24	10	14	
		Driver enabled (DE at V_{CC}), Receiver disabled (RE at V_{CC}), No load, $V_I = 0\text{ V or }V_{CC}$	SN65HVD20	5	8	
			SN65HVD21	7	11	
			SN65HVD22	5	8	
			SN65HVD23	5	9	
		Driver disabled (DE at 0 V), Receiver enabled (RE at 0 V), No load	SN65HVD24	8	12	
			SN65HVD20	4	7	
			SN65HVD21	5	8	
			SN65HVD22	4	7	
		Driver disabled (DE at 0 V), Receiver disabled (RE at V_{CC}) D open	SN65HVD23	4.5	9	
			SN65HVD24	5.5	10	
				All SN65HVD2x		
T_A	Operating free-air temperature ⁽¹⁾		-40	85	$^{\circ}\text{C}$	
T_J	Junction temperature		-40	130	$^{\circ}\text{C}$	

(1) Maximum free-air temperature operation is allowed as long as the device recommended junction temperature is not exceeded.

8.4 Thermal Information

THERMAL METRIC ⁽¹⁾		SN65HVD2x		UNIT
		D (SOIC)	P (PDIP)	
		8 PINS	8 PINS	
R _{θJA}	Junction-to-ambient thermal resistance	110.7	52.5	°C/W
R _{θJC(top)}	Junction-to-case(top) thermal resistance	49.9	57.6	°C/W
R _{θJB}	Junction-to-board thermal resistance	56.7	38.6	°C/W
ψ _{JT}	Junction-to-top characterization parameter	6.0	19.1	°C/W
ψ _{JB}	Junction-to-board characterization parameter	55.9	31.9	°C/W

(1) For more information about traditional and new thermal metrics, see the [Semiconductor and IC Package Thermal Metrics](#) application report.

8.5 Driver Electrical Characteristics

over recommended operating conditions (unless otherwise noted).⁽¹⁾

PARAMETER		TEST CONDITIONS	MIN	TYP	MAX	UNIT
V _{IK}	Input clamp voltage	I _I = -18 mA	-1.5	0.75		V
V _O	Open-circuit output voltage	A or B, No load	0		V _{CC}	V
V _{OD(SS)}	Steady-state differential output voltage	No load (open circuit)	3.3	4.2	V _{CC}	V
		R _L = 54 Ω, See Figure 9-1	1.8	2.5		
		With common-mode loading, See Figure 9-2	1.8			
Δ V _{OD(SS)}	Change in steady-state differential output voltage between logic states	See Figure 9-1 and Figure 9-3	-0.1		0.1	V
V _{OC(SS)}	Steady-state common-mode output voltage	See Figure 9-1	2.1	2.5	2.9	V
ΔV _{OC(SS)}	Change in steady-state common-mode output voltage, V _{OC(H)} - V _{OC(L)}	See Figure 9-1 and Figure 9-4	-0.1		0.1	V
V _{OC(PP)}	Peak-to-peak common-mode output voltage, V _{OC(MAX)} - V _{OC(MIN)}	R _L = 54 Ω, C _L = 50 pF, See Figure 9-1 and Figure 9-4	0.35			V
V _{OD(RING)}	Differential output voltage over and under shoot	R _L = 54 Ω, C _L = 50 pF, See Figure 9-5			10%	
I _I	Input current	D, DE	-100		100	μA
I _O	Output current with power off. High impedance state output current.	V _O = -7 V to 12 V, Other input = 0 V	SN65HVD2[0,3]	-400	500	μA
			SN65HVD2[1,2,4]	-100	125	
		V _O = -20 V to 25 V, Other input = 0 V	SN65HVD2[0,3]	-800	1000	
			SN65HVD2[1,2,4]	-200	250	
I _{OS}	Short-circuit output current	V _O = -20 V to 25 V, See Figure 9-9	-250		250	mA
C _{OD}	Differential output capacitance				20	pF

(1) All typical values are at V_{CC} = 5 V and 25°C.

8.6 Receiver Electrical Characteristics

over recommended operating conditions (unless otherwise noted)⁽¹⁾

PARAMETER		TEST CONDITIONS	MIN	TYP	MAX	UNIT	
$V_{IT(+)}$	Positive-going differential input voltage threshold	See Figure 9-10 $V_O = 2.4 \text{ V}$, $I_O = -8 \text{ mA}$		60	200	mV	
$V_{IT(-)}$	Negative-going differential input voltage threshold		$V_O = 0.4 \text{ V}$, $I_O = 8 \text{ mA}$	-200	-60		
V_{HYS}	Hysteresis voltage ($V_{IT+} - V_{IT-}$)		100	130		mV	
$V_{IT(F+)}$	Positive-going differential input failsafe voltage threshold	See Figure 9-15 VCM = -7 V to 12 V VCM = -20 V to 25 V		40	120	200	mV
$V_{IT(F-)}$	Negative-going differential input failsafe voltage threshold		VCM = -7 V to 12 V VCM = -20 V to 25 V	-200	-120	-40	
V_{IK}	Input clamp voltage	$I_I = -18 \text{ mA}$	-1.5			V	
V_{OH}	High-level output voltage	$V_{ID} = 200 \text{ mV}$, $I_{OH} = -8 \text{ mA}$, See Figure 9-11	4			V	
V_{OL}	Low-level output voltage	$V_{ID} = -200 \text{ mV}$, $I_{OL} = 8 \text{ mA}$, See Figure 9-11			0.4	V	
$I_{I(BUS)}$	Bus input current (power on or power off)	$V_I = -7 \text{ to } 12 \text{ V}$, Other input = 0 V	SN65HVD2[0,3]	-400		500	μA
			SN65HVD2[1,2,4]	-100		125	
		$V_I = -20 \text{ to } 25 \text{ V}$, Other input = 0 V	SN65HVD2[0,3]	-800		1000	
			SN65HVD2[1,2,4]	-200		250	
I_I	Input current	\overline{RE}	-100		100	μA	
R_I	Input resistance	SN65HVD2[0,3]	24			k Ω	
		SN65HVD2[1,2,4]	96				
C_{ID}	Differential input capacitance	$V_{ID} = 0.5 + 0.4 \text{ sine}(2\pi \times 1.5 \times 10^6 t)$		20		pF	

(1) All typical values are at $V_{CC} = 5 \text{ V}$ and 25°C .

8.7 Driver Switching Characteristics

over recommended operating conditions (unless otherwise noted)⁽¹⁾

PARAMETER		TEST CONDITIONS	MIN	TYP	MAX	UNIT	
t_{PLH} , t_{PHL}	Differential output propagation delay, low-to-high and high-to-low	$R_L = 54 \Omega$, $C_L = 50 \text{ pF}$, See Figure 9-3	SN65HVD2[0,3]	6	10	20	ns
		SN65HVD2[1,4]	20	32	60		
		SN65HVD22	160	280	500		
t_r , t_f	Differential output rise time and fall time	$R_L = 54 \Omega$, $C_L = 50 \text{ pF}$, See Figure 9-3	SN65HVD2[0,3]	2	6	12	ns
			SN65HVD2[1,4]	20	40	60	
			SN65HVD22	175	400	600	
t_{PZH} , t_{PHZ}	Propagation delay time, high-impedance-to-high-level output and high-level output-to-high-impedance	\overline{RE} at 0 V, See Figure 9-6	SN65HVD2[0,3]			40	ns
			SN65HVD2[1,4]			100	
			SN65HVD22			300	
t_{PZL} , t_{PLZ}	Propagation delay time, high-impedance-to-high-level output and high-level output-to-high-impedance	\overline{RE} at 0 V, See Figure 9-7	SN65HVD2[0,3]			40	ns
			SN65HVD2[1,4]			100	
			SN65HVD22			300	
$t_{d(\text{standby})}$	Time from an active differential output to standby				2	μs	
$t_{d(\text{wake})}$	Wake-up time from standby to an active differential output	\overline{RE} at V_{CC} , See Figure 9-8			8	μs	
$t_{sk(p)}$	Pulse skew $t_{PLH} - t_{PHL}$	SN65HVD2[0,3]			2	ns	
		SN65HVD2[1,4]			6		
		SN65HVD22			50		

(1) All typical values are at $V_{CC} = 5 \text{ V}$ and 25°C .

8.8 Receiver Switching Characteristics

over recommended operating conditions (unless otherwise noted)

PARAMETER		TEST CONDITIONS	MIN	TYP	MAX	UNIT
t_{PLH}	Propagation delay time, low-to-high level output and high-to low level output	See Figure 9-11	SN65HVD2[0,3]	16	35	ns
t_{PHL}			SN65HVD2[1,2,4]	25	50	
t_r t_f	Receiver output rise time Receiver output fall time	See Figure 9-11		2	4	ns
t_{PZH} t_{PHZ}	Receiver output enable time to high level and disable time from high level	See Figure 9-12		90	120	ns
				16	35	
t_{PZL} t_{PLZ}	Receiver output enable time to low level and disable time from low level	See Figure 9-13		90	120	ns
				16	35	
$t_{r(standby)}$	Time from an active receiver output to standby	See Figure 9-14, DE at 0 V			2	μ s
$t_{r(wake)}$	Wake-up time from standby to an active receiver output	See Figure 9-14, DE at 0 V			8	μ s
$t_{sk(p)}$	Pulse skew $ t_{PLH} - t_{PHL} $				5	ns
$t_{p(set)}$	Delay time, bus fail to failsafe set	See Figure 9-15, pulse rate = 1 kHz		250	350	μ s
$t_{p(reset)}$	Delay time, bus recovery to failsafe reset	See Figure 9-15, pulse rate = 1 kHz		50		ns

8.9 Receiver Equalization Characteristics

over recommended operating conditions (unless otherwise noted)^{(1) (2)}

PARAMETER	TEST CONDITIONS	TYP	UNIT			
$t_{j(pp)}$ Peak-to-peak eye-pattern jitter	Peudo-random NRZ code with a bit pattern length of $2^{16} - 1$, Beldon 3105A cable, See Figure 10-2	25 Mbps	0 m	SN65HVD23	2	ns
			100 m	SN65HVD20	6	
				SN65HVD23	3	
		150 m	SN65HVD20	15	ns	
			SN65HVD23	4		
		200 m	SN65HVD20	27	ns	
			SN65HVD23	8		
		10 Mbps	200 m	SN65HVD20	22	ns
				SN65HVD23	8	
			250 m	SN65HVD20	34	ns
				SN65HVD23	15	
		300 m	SN65HVD20	49	ns	
			SN65HVD23	27		
		5 Mbps	500 m	SN65HVD21	128	ns
				SN65HVD24	18	
		3 Mbps	500 m	SN65HVD20	93	ns
SN65HVD21	103					
SN65HVD23	90					
SN65HVD24	16					
1 Mbps	1000 m	SN65HVD21	216	ns		
		SN65HVD24	62			

- (1) The SN65HVD20 and SN65HVD21 do not have receiver equalization, but are specified for comparison.
 (2) All typical values are at $V_{CC} = 5$ V, and temperature = 25°C.

8.10 Power Dissipation

PARAMETERS		TEST CONDITIONS			VALUE	UNIT
P _D	Device power dissipation	Typical	V _{CC} = 5 V, T _J = 25°C, R _L = 54 Ω, C _L = 50 pF (driver), C _L = 15 pF (receiver), 50% Duty cycle square-wave signal, Driver and receiver enabled	SN65HVD20: 25 Mbps	295	mW
				SN65HVD21: 5 Mbps	260	
				SN65HVD22: 500 kbps	233	
				SN65HVD23: 25 Mbps	302	
				SN65HVD24: 5 Mbps	267	
		Worst case	V _{CC} = 5.5 V, T _J = 125°C, R _L = 54 Ω, C _L = 50 pF, C _L = 15 pF (receiver), 50% Duty cycle square-wave signal, Driver and receiver enabled	SN65HVD20: 25 Mbps	408	mW
				SN65HVD21: 5 Mbps	342	
				SN65HVD22: 500 kbps	300	
				SN65HVD23: 25 Mbps	417	
				SN65HVD24: 5 Mbps	352	
T _{SD}	Thermal shut down junction temperature			170	°C	

8.11 Typical Characteristics

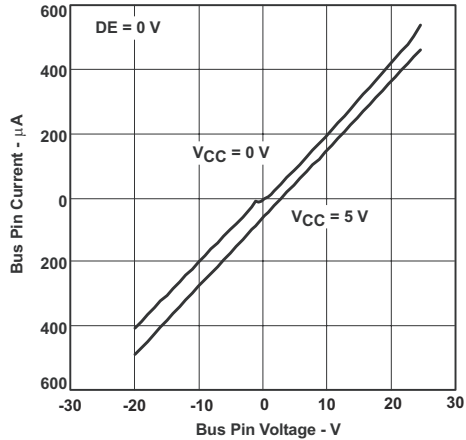

Figure 8-1. SN65HVD2[0,3] Bus Pin Current vs Bus Pin Voltage

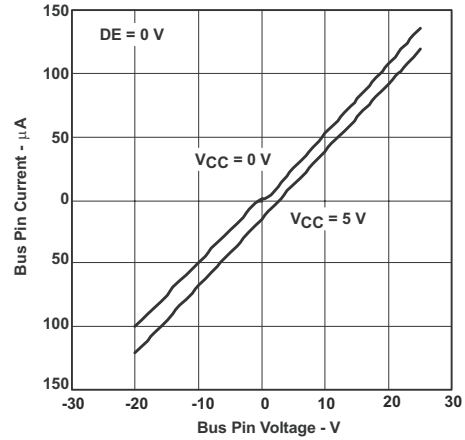

Figure 8-2. SN65HVD2[1,2,4] Bus Pin Current vs Bus Pin Voltage

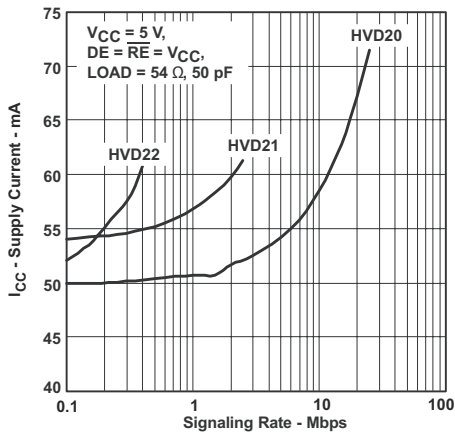

Figure 8-3. Supply Current vs Signaling Rate

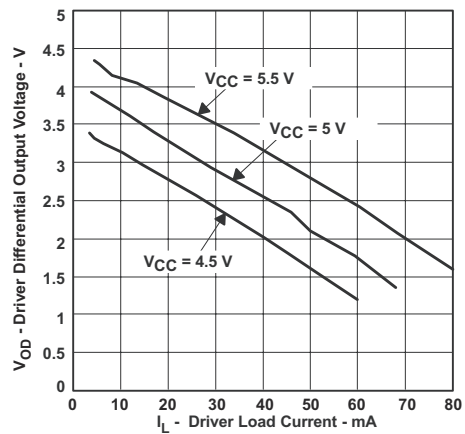

Figure 8-4. Driver Differential Output Voltage vs Driver Load Current

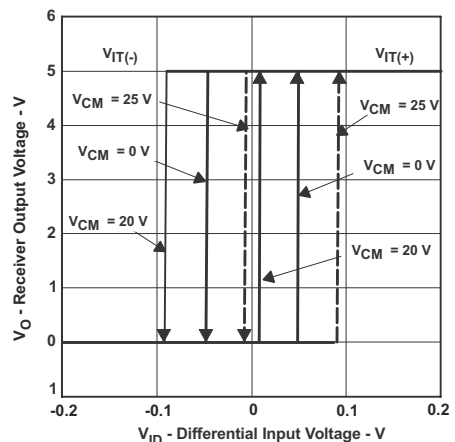

Figure 8-5. Receiver Output Voltage vs Differential Input Voltage

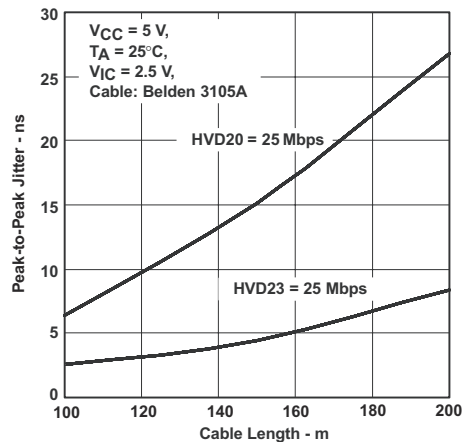

Figure 8-6. SN65HVD2[0,3] Peak-to-Peak Jitter vs Cable Length

8.11 Typical Characteristics (continued)

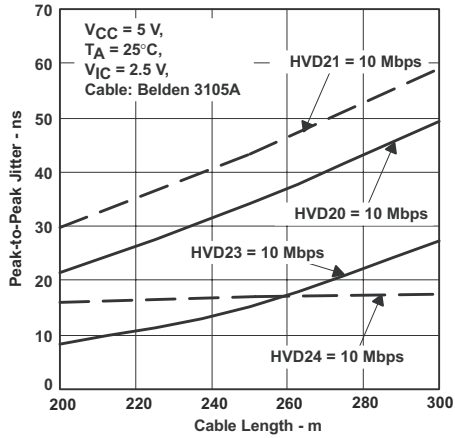

Figure 8-7. SN65HVD2[0,1,3,4] Peak-to-Peak Jitter vs Cable Length

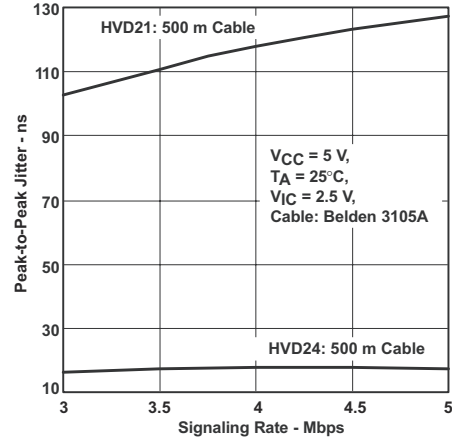

Figure 8-8. SN65HVD2[1,4] Peak-to-Peak Jitter vs Signaling Rate

9 Parameter Measurement Information

Note

Test load capacitance includes probe and jig capacitance (unless otherwise specified). Signal generator characteristics: rise and fall time < 6 ns, pulse rate 100 kHz, 50% duty cycle, $Z_O = 50 \Omega$ (unless otherwise specified).

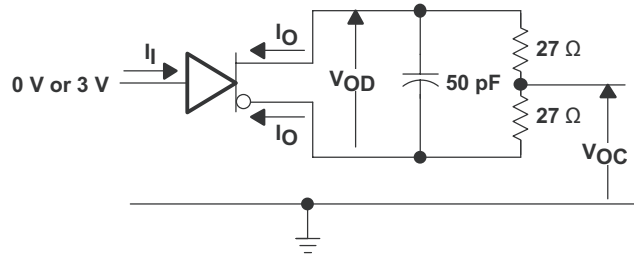

Figure 9-1. Driver Test Circuit, V_{OD} and V_{OC} Without Common-Mode Loading

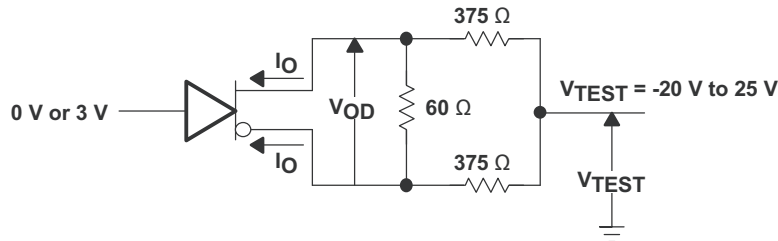

Figure 9-2. Driver Test Circuit, V_{OD} With Common-Mode Loading

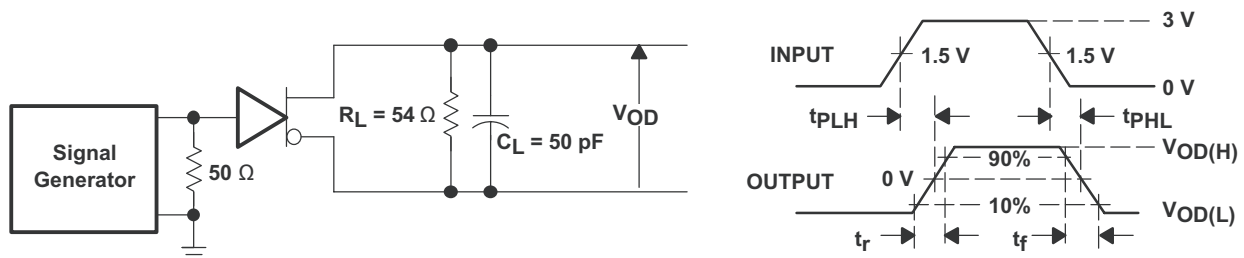

Figure 9-3. Driver Switching Test Circuit and Waveforms

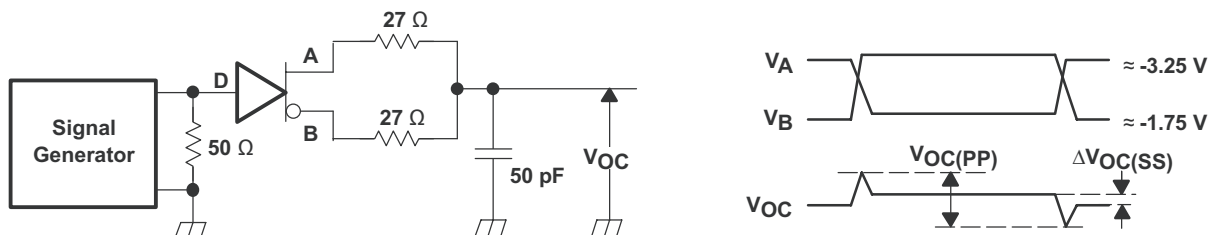
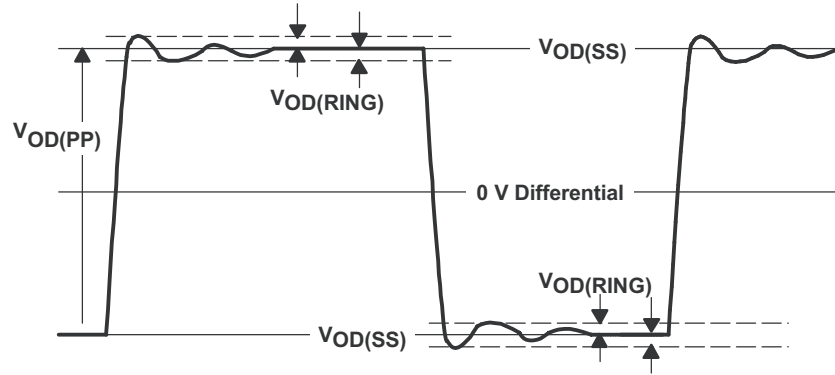

Figure 9-4. Driver V_{OC} Test Circuit and Waveforms



$V_{OD(RING)}$ is measured at four points on the output waveform, corresponding to overshoot and undershoot from the $V_{OD(H)}$ and $V_{OD(L)}$ steady state values.

Figure 9-5. $V_{OD(RING)}$ Waveform and Definitions

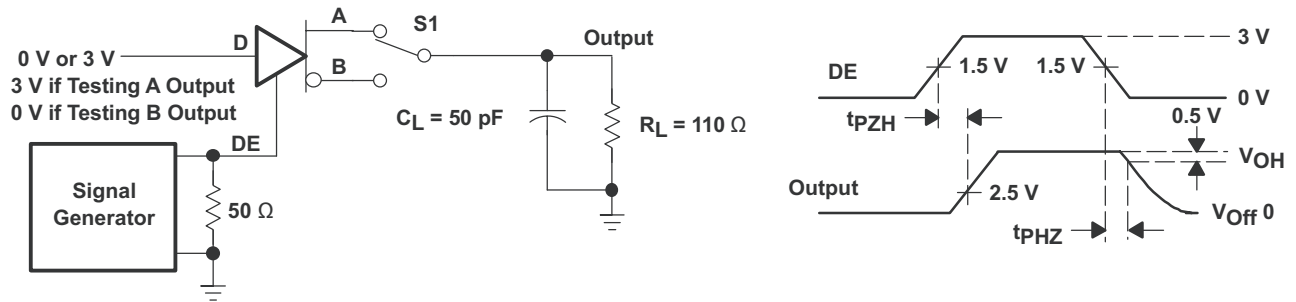

Figure 9-6. Driver Enable and Disable Test, High Output

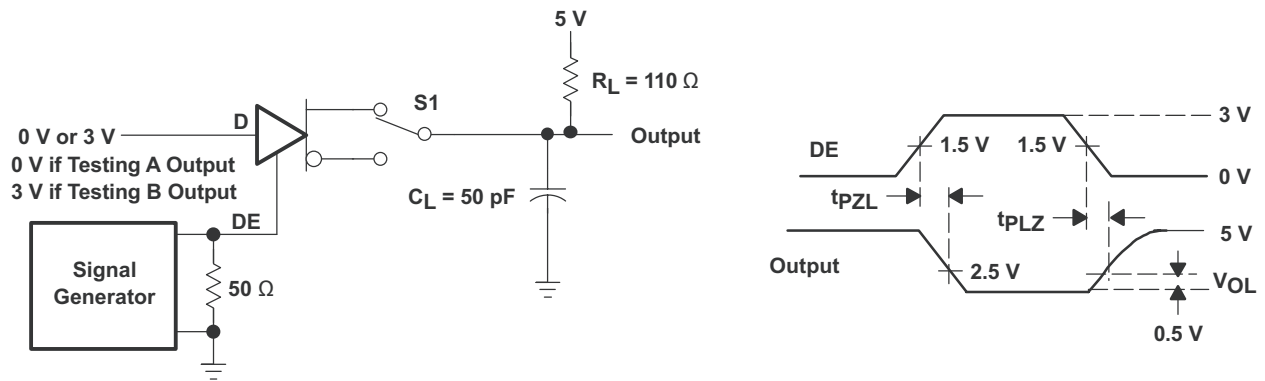

Figure 9-7. Driver Enable and Disable Test, Low Output

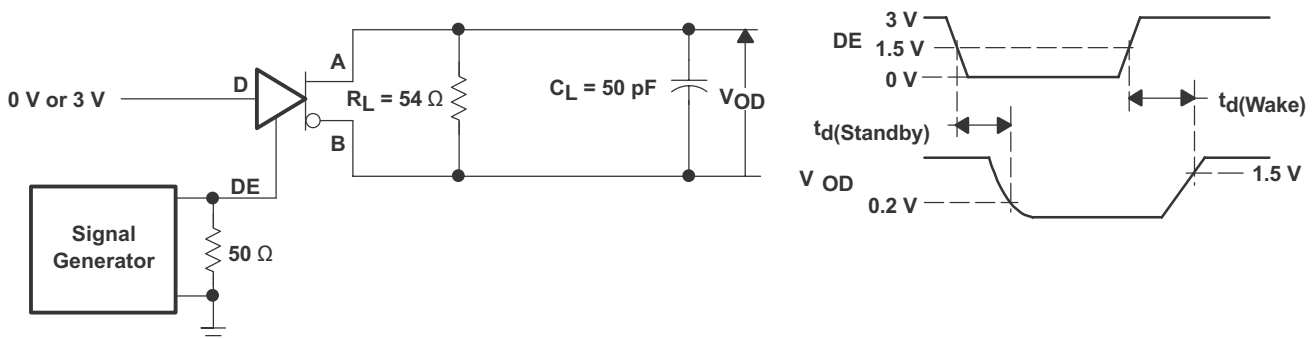

Figure 9-8. Driver Standby and Wake Test Circuit and Waveforms

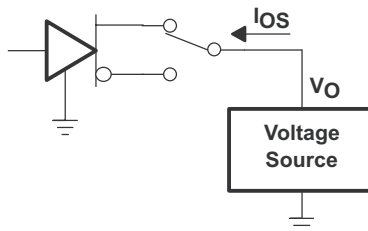

Figure 9-9. Driver Short-Circuit Test

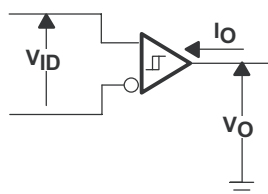

Figure 9-10. Receiver DC Parameter Definitions

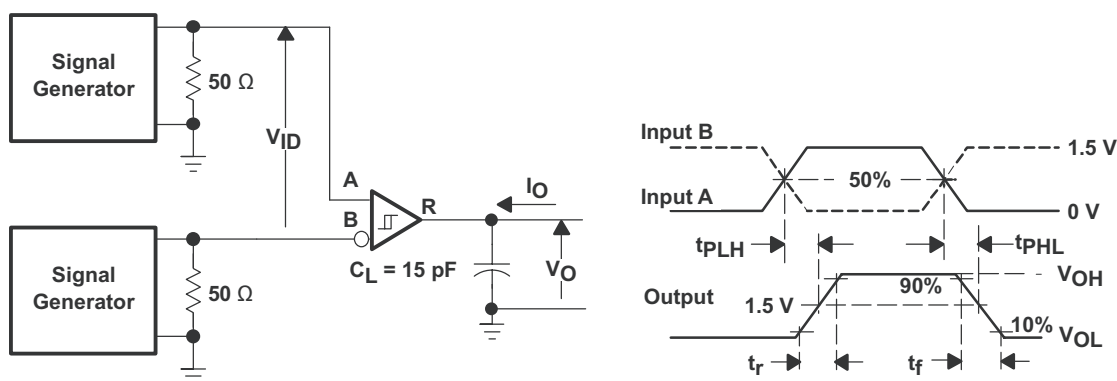

Figure 9-11. Receiver Switching Test Circuit and Waveforms

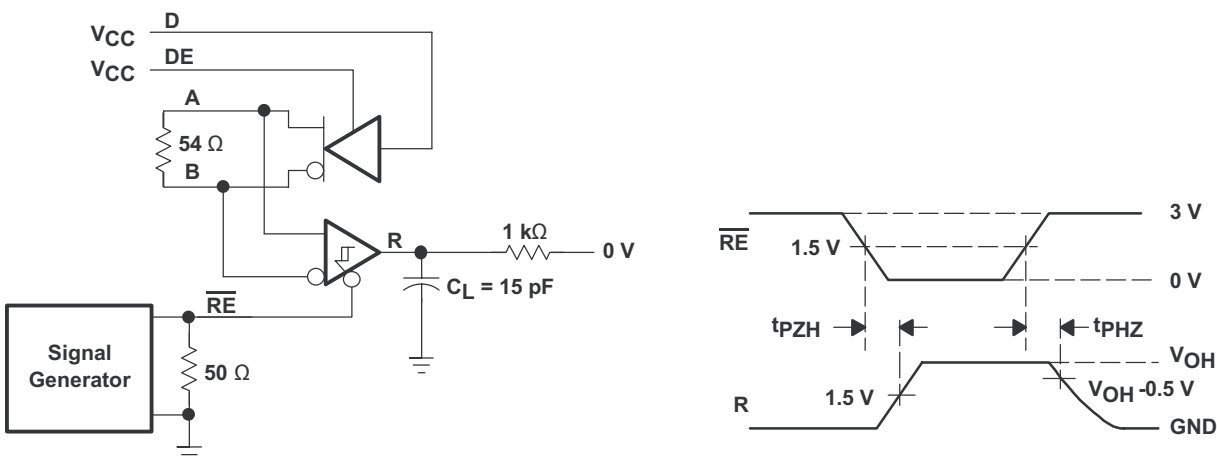

Figure 9-12. Receiver Enable Test Circuit and Waveforms, Data Output High

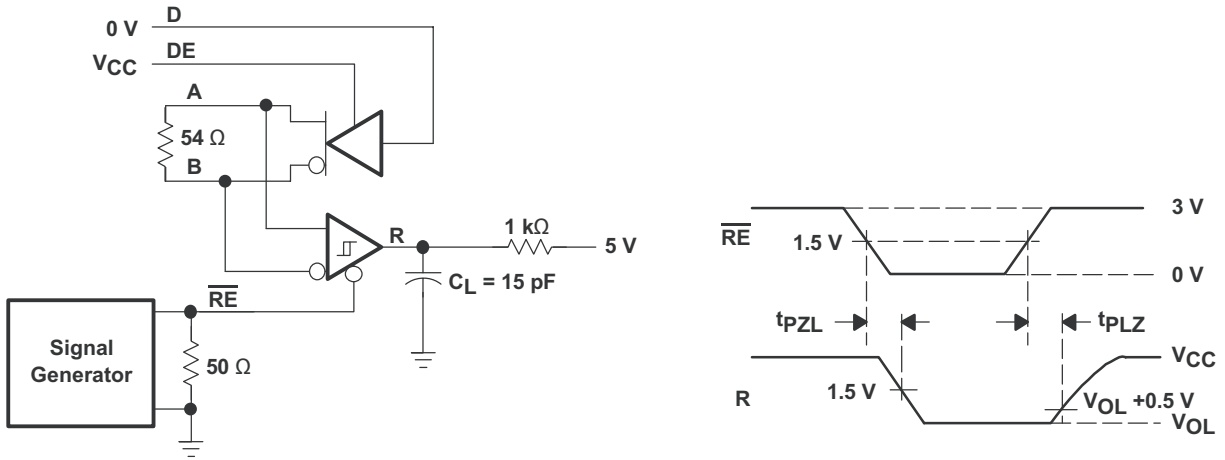

Figure 9-13. Receiver Enable Test Circuit and Waveforms, Data Output Low

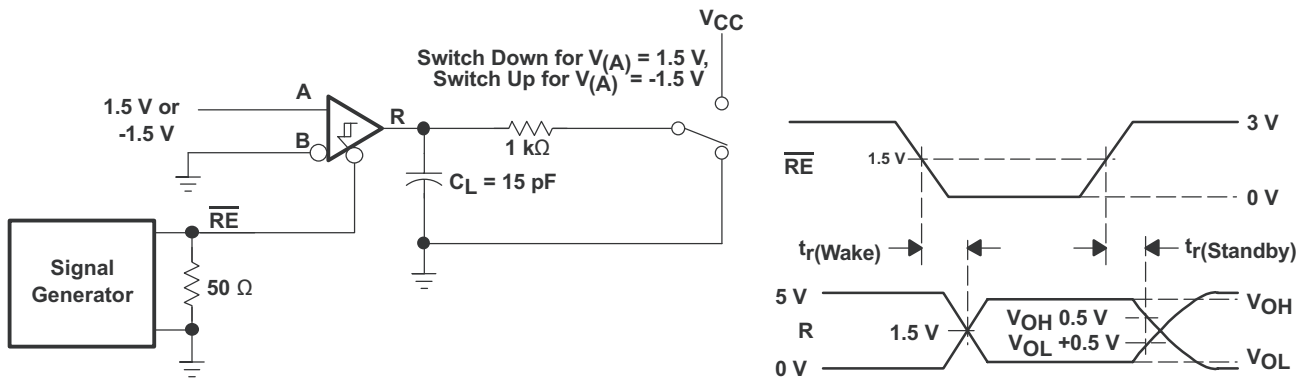

Figure 9-14. Receiver Standby and Wake Test Circuit and Waveforms

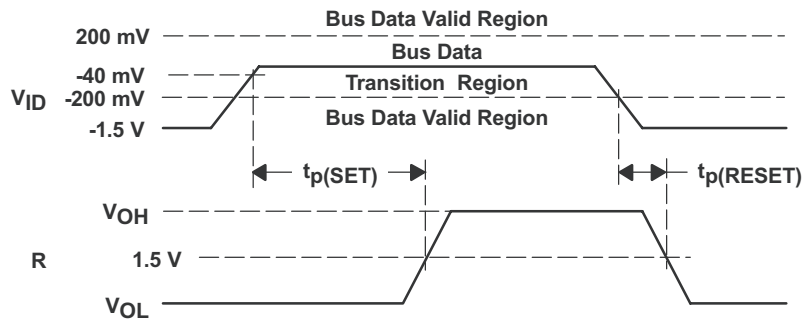

Figure 9-15. Receiver Active Failsafe Definitions and Waveforms

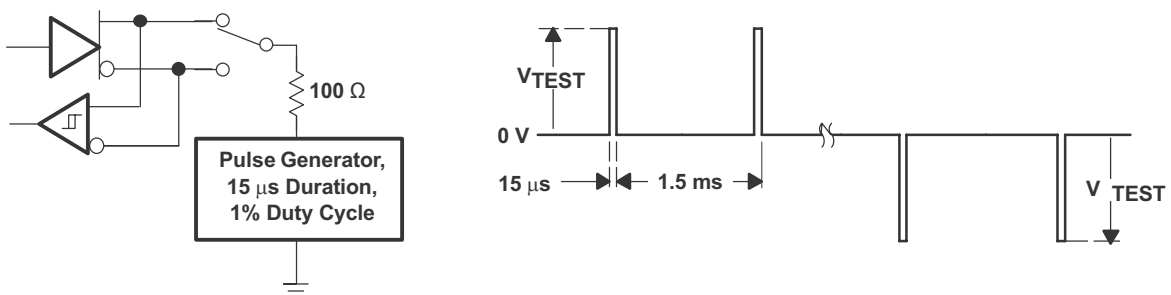

Figure 9-16. Test Circuit and Waveforms, Transient Overvoltage Test

10 Detailed Description

10.1 Overview

The SN65HVD2x family of devices are RS-485 compliant half-duplex transceivers designed for communication rates up to 500 kbps (SN65HVD22), 3 Mbps (SN65HVD24), 5 Mbps (SN65HVD21), or 25 Mbps (SN65HVD20 and SN65HVD23). The devices feature extended common-mode range support, which provides immunity to larger ground potential differences that can occur between nodes that communicate over longer distances. The SN65HVD23 and the SN65HVD24 devices feature receiver equalization, which reduces the amount of data-dependent jitter that is introduced by the high-frequency losses associated with long cables.

10.2 Functional Block Diagram

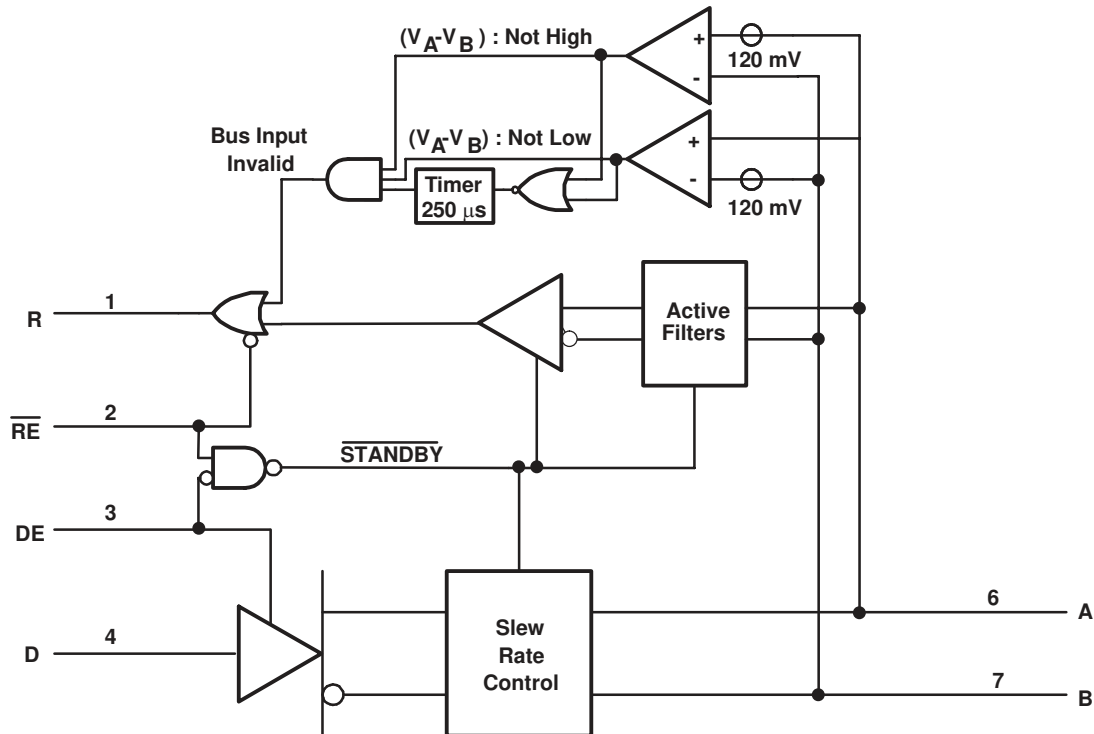

Copyright © 2016, Texas Instruments Incorporated

10.3 Feature Description

The SN65HVD2x family of devices integrates a differential receiver and differential driver with additional features for improved performance in electrically-noisy, long-cable, or other fault-intolerant applications.

The receiver hysteresis (typically 130 mV) is much larger than found in typical RS-485 transceivers. This helps reject spurious noise signals which would otherwise cause false changes in the receiver output state.

Slew rate limiting on the driver outputs (SN65HVD2[1,2,4]) reduces the high-frequency content of signal edges. This decreases reflections from bus discontinuities, and allows longer stub lengths between nodes and the main bus line. Designers must consider the maximum signaling rate and cable length required for a specific application, and choose the transceiver best matching those requirements.

When DE is low, the differential driver is disabled, and the A and B outputs are in high-impedance states. When DE is high, the differential driver is enabled, and drives the A and B outputs according to the state of the D inputs.

When RE is high, the differential receiver output buffer is disabled, and the R output is in a high-impedance state. When RE is low, the differential receiver is enabled, and the R output reflects the state of the differential bus inputs on the A and B pins.

If both the driver and receiver are disabled, (DE low and \overline{RE} high) then all nonessential circuitry, including auxiliary functions such as failsafe and receiver equalization is placed in a low-power standby state. This reduces power consumption to less than 5 μ W. When either enable input is asserted, the circuitry again becomes active.

In addition to the primary differential receiver, these devices incorporate a set of comparators and logic to implement an active receiver failsafe feature. These components determine whether the differential bus signal is valid. Whenever the differential signal is close to zero volts (neither high nor low), a timer initiates. If the differential input remains within the transition range for more than 250 μ s, the timer expires and set the receiver output to the high state. If a valid bus input (high or low) is received at any time, the receiver output reflects the valid bus state, and the timer is reset.

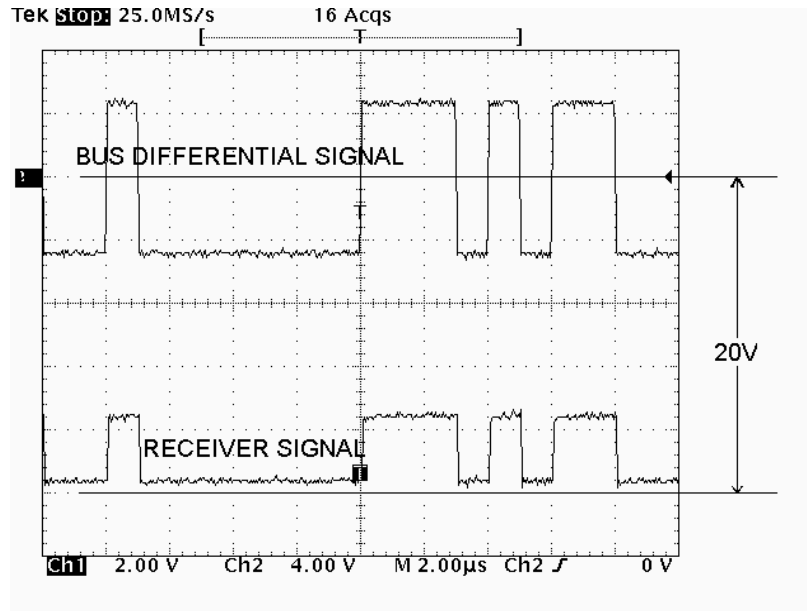

Figure 10-1. SN65HVD22 Receiver Operation With 20-V Offset on Input Signal

$H(s) = k_0 \left[(1-k_1) + \frac{k_1 p_1}{(s + p_1)} \right] \left[(1-k_2) + \frac{k_2 p_2}{(s + p_2)} \right] \left[(1-k_3) + \frac{k_3 p_3}{(s + p_3)} \right]$	k0 (DC loss)	p1 (MHz)	k1	p2 (MHz)	k2	p3 (MHz)	k3
Similar to 160m of Belden 3105A	0.95	0.25	0.3	3.5	0.5	15	1
Similar to 250m of Belden 3105A	0.9	0.25	0.4	3.5	0.7	12	1
Similar to 500m of Belden 3105A	0.8	0.25	0.6	2.2	1	8	1
Similar to 1000m of Belden 3105A	0.6	0.3	1	3	1	6	1

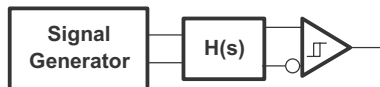

Figure 10-2. Cable Attenuation Model for Jitter Measurements

10.4 Device Functional Modes

The driver and receiver behavior for different input conditions are shown in Table 10-1 and Table 10-2, respectively.

Table 10-1. Driver Function Table⁽¹⁾

DEVICE	INPUT	ENABLE	OUTPUTS	
	D	DE	A	B
SN65HVD2[0,1,2]	H	H	H	L
	L	H	L	H
	X	L	Z	Z
	X	OPEN	Z	Z
	OPEN	H	H	L
SN65HVD2[3,4]	H	H	H	L
	L	H	L	H
	X	L	Z	Z
	X	OPEN	Z	Z
	OPEN	H	L	H

(1) Legend: H = high level, L = low level, X = don't care, Z = high impedance (off), ? = indeterminate

Table 10-2. Receiver Function Table⁽¹⁾

DIFFERENTIAL INPUT $V_{ID} = (V_A - V_B)$	ENABLE RE	OUTPUT R
$0.2\text{ V} \leq V_{ID}$	L	H
$-0.2\text{ V} < V_{ID} < 0.2\text{ V}$	L	H ⁽²⁾
$V_{ID} \leq -0.2\text{ V}$	L	L
X	H	Z
X	OPEN	Z
Open circuit	L	H
Short Circuit	L	H
Idle (terminated) bus	L	H

- (1) H = high level, L = low level, Z = high impedance (off)
 (2) If the differential input V_{ID} remains within the transition range for more than 250 μs , the integrated failsafe circuitry detects a bus fault, and set the receiver output to a high state. See Figure 9-15.

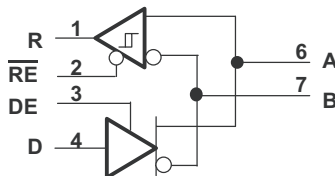

Figure 10-3. Logic Diagram

10.4.1 Test Mode Driver Disable

If the input signal to the D pin is such that:

1. the signal has signaling rate above 4 Mbps (for the SN65HVD21 and SN65HVD24),
2. the signal has signaling rate above 6 Mbps (for the SN65HVD20 and SN65HVD23),
3. the signal has average amplitude from 1.2 V to 1.6 V ($1.4\text{ V} \pm 200\text{ mV}$), or
4. the average signal amplitude remains in this range for 100 μs or longer,

then the driver may activate a test-mode during which the driver outputs are temporarily disabled. This can cause loss of transmission of data during the period that the device is in the test-mode. The driver is re-enabled and resumes normal operation whenever the above conditions are not true. The device is not damaged by this test mode.

Although rare, there are combinations of specific voltage levels and input data patterns within the operating conditions of the SN65HVD2x family which may lead to a temporary state where the driver outputs are disabled for a period of time.

Observations:

1. The conditions for inadvertently entering the test mode are dependent on the levels, duration, and duty cycle of the logic signal input to the D pin. Operating input levels are specified as greater than 2 V for a logic HIGH input, and less than 0.8 V for a logic LOW input. Therefore, a valid steady-state logic input does not cause the device to activate the test mode
2. Only input signals with frequency content above 2 MHz (4 Mbps) have a possibility of activating the test mode. Therefore, this issue should not affect the normal operation of the SN65HVD22 (500 kbps).
3. For operating signaling rates of 4 Mbps (or above), the conditions stated above must remain true over a period of: $4\text{ Mbps} \times 100\ \mu\text{s} = 400\text{ bits}$. Therefore, a normal short message does not inadvertently activate the test mode.
4. One example of an input signal which may cause the test mode to activate is a clock signal with frequency 3 MHz and 50% duty cycle (symmetric HIGH and LOW half-cycles) with logic HIGH levels of 2.4 V and logic LOW levels of 0.4 V. This signal applied to the D pin as a driver input would meet the criteria listed above, and may cause the test-mode to activate, which would disable the driver. This example situation may occur if the clock signal is generated from a microcontroller or logic chip with a 2.7-V supply.

10.4.2 Equivalent Input and Output Schematic Diagrams

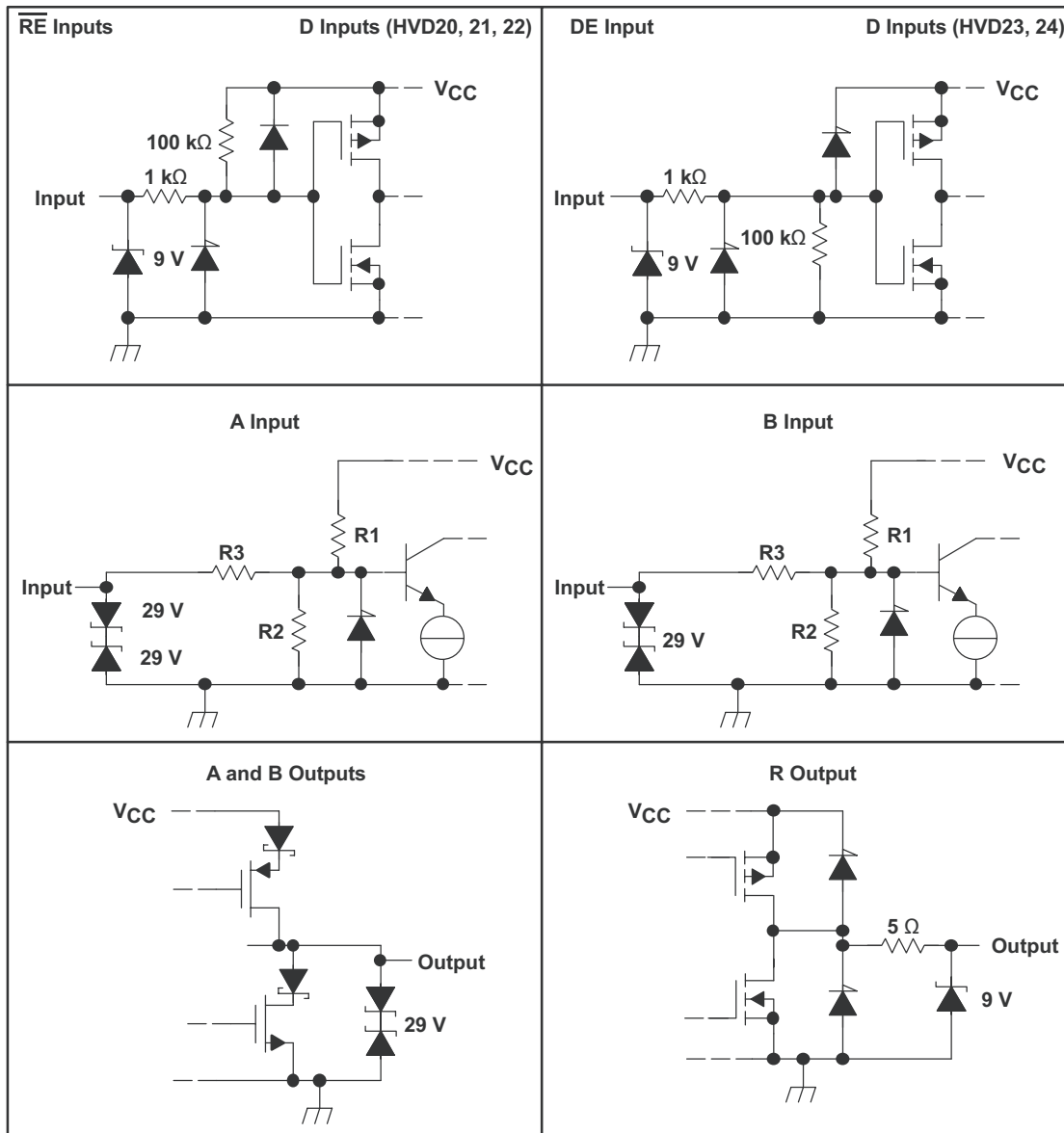

Figure 10-4. Equivalent Input and Output Schematic Diagrams

Table 10-3. Input and Output Resistor Values

DEVICE	R1, R2	R3
SN65HVD2[0,3]	9 kΩ	45 kΩ
SN65HVD2[1,2,4]	36 kΩ	180 kΩ

11 Application and Implementation

Note

Information in the following applications sections is not part of the TI component specification, and TI does not warrant its accuracy or completeness. TI's customers are responsible for determining suitability of components for their purposes, as well as validating and testing their design implementation to confirm system functionality.

11.1 Application Information

The SN65HVD2x devices are half-duplex RS-485 transceivers that can be used for bidirectional, multipoint communication at various data rates over differential transmission lines. These devices support a wide common-mode range, allowing for robust communication even in the presence of voltage differences between the reference potentials of different nodes on a network.

11.2 Typical Application

Figure 11-1 shows a typical RS-485 application. Transceivers of different nodes are connected to one another over a shared bus. Twisted-pair cabling with a controlled differential impedance is used, and termination resistances are placed at the two ends of the cable to match the transmission line impedance and minimize signal reflections.

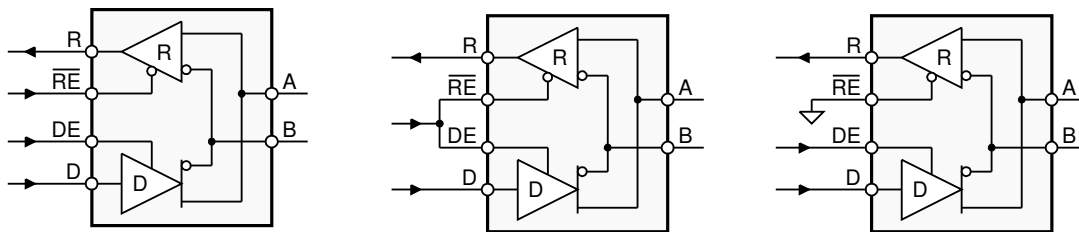

Copyright © 2016, Texas Instruments Incorporated

Figure 11-1. Half-Duplex Transceiver Configurations

11.2.1 Design Requirements

As the distances between nodes in an RS-485 network become greater and greater, it becomes more of a challenge to ensure reliable communication. The increased distance often means that the reference (ground) potentials has more of a difference between nodes. These ground potential differences give rise to differences in the common-mode voltages seen by the various transceivers on the bus. Standard RS-485 transceivers are typically specified to operate over a common-mode voltage from -7 V to 12 V , which may be insufficient for larger distances. The SN65HVD2x family of devices extends this range to -20 V to 25 V , allowing for greater communication distances between nodes.

Increased cable lengths can lead to increased jitter, especially in links operating at high data rates. This increased jitter is due to the attenuation of the cable, which tends to increase with frequency. Having unequal loss between higher and lower frequencies causes the RS-485 signal to distort, adding some timing deviation (jitter) to the edge crossings of the RS-485 data. If the jitter amplitude exceeds the jitter tolerance of the receiving MCU or UART, then bit errors are likely to result in the link. However, jitter can be reduced for a given link through the use of receiver equalization.

11.2.2 Detailed Design Procedure

11.2.2.1 Noise Considerations for Equalized Receivers

The simplest way of overcoming the effects of cable losses is to increase the sensitivity of the receiver. If the maximum attenuation of frequencies of interest is 20 dB , increasing the receiver gain by a factor of ten compensates for the cable. However, this means that signal and noise are amplified. Therefore, the receiver with

higher gain is more sensitive to noise and it is important to minimize differential noise coupling to the equalized receiver.

Differential noise is created when conducted or radiated noise energy generates more voltage on one line of the differential pair than the other. For this to occur from conducted or electric far-field noise, the impedance to ground of the lines must differ.

For noise frequency out to 50 MHz, the input traces can be treated as a lumped capacitance if the receiver is approximately 10 inches or less from the connector. Therefore, matching impedance of the lines is accomplished by matching the lumped capacitance of each.

The primary factors that affect the capacitance of a trace are in length, thickness, width, dielectric material, distance from the signal return path, stray capacitance, and proximity to other conductors. It is difficult to match each of the variables for each line of the differential pair exactly, but a reasonable effort to do so keeps the lines balanced and less susceptible to differential noise coupling.

Another source of differential noise is from near-field coupling. In this situation, an assumption of equal noise-source impedance cannot be made as in the far-field. Familiarly known as crosstalk, more energy from a nearby signal is coupled to one line of the differential pair. Minimization of this differential noise is accomplished by keeping the signal pair close together and physical separation from high-voltage, high-current, or high-frequency signals.

In summary, follow these guidelines in board layout for keeping differential noise to a minimum.

- Keep the differential input traces short.
- Match the length, physical dimensions, and routing of each line of the pair.
- Keep the lines close together.
- Match components connected to each line.
- Separate the inputs from high-voltage, high-frequency, or high-current signals.

11.2.3 Application Curves

[Figure 11-2](#) illustrates the benefits of integrated receiver equalization as implemented in the SN65HVD23 transceiver. In this test setup, a differential signal generator applied a signal voltage at one end of the cable, which was Belden 3105A twisted-pair shielded cable. The test signal was a pseudo-random bit stream (PRBS) of nonreturn-to-zero (NRZ) data. Channel 1 (top) shows the eye-pattern of the differential voltage at the receiver inputs (after the cable attenuation). Channel 2 (bottom) shows the output of the receiver.

[Figure 11-3](#) illustrates the benefits of integrated receiver equalization as implemented in the SN65HVD24 transceiver. In this test setup, a differential signal generator applied a signal voltage at one end of the cable, which was Belden 3105A twisted-pair shielded cable. The test signal was a pseudo-random bit stream (PRBS) of nonreturn-to-zero (NRZ) data. Channel 1 (top) shows the eye-pattern of the bit stream. Channel 2 (middle) shows the eye-pattern of the differential voltage at the receiver inputs (after the cable attenuation). Channel 3 (bottom) shows the output of the receiver.

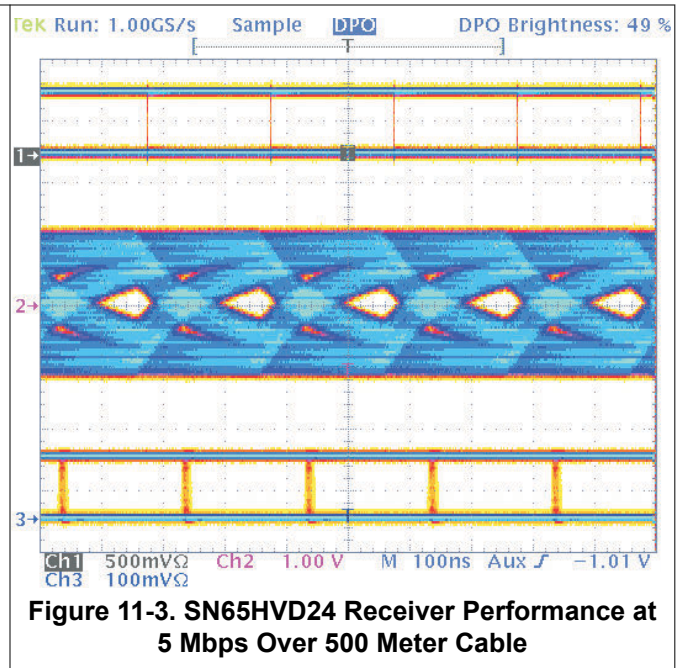
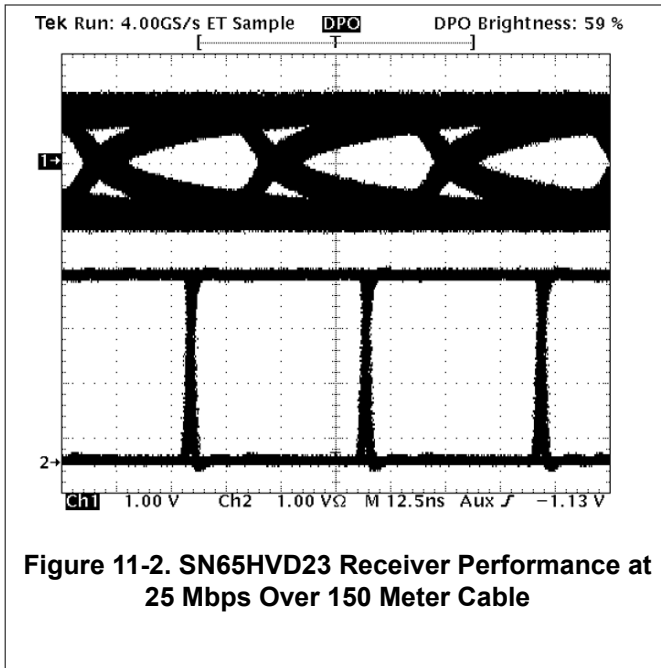

12 Power Supply Recommendations

To ensure reliable operation at all data rates and supply voltages, each supply must be decoupled with a 100-nF ceramic capacitor placed as close to the supply pins as possible. This helps to reduce supply voltage ripple present on the outputs of switched-mode power supplies and also helps to compensate for the resistance and inductance of the PCB power planes.

13 Layout

13.1 Layout Guidelines

In addition to the guidelines on differential trace matching given in [Section 11.2.2](#), the layout guidelines below must be followed:

- Route power and ground nets as planes rather than traces, and keep their widths as large as possible to minimize resistance and inductance while maximizing parasitic capacitance.
- If external components (like transient voltage suppression diodes) are used for transient protection, place them close to the connector port and within the path of the signal lines. Make sure component capacitances are small enough not to impact the RS-485 signaling at the chosen data rate.
- Small-valued series pulse-proof resistances can be used to provide additional immunity to transients. This is needed to limit input currents if the clamping voltages of external transient protection devices exceed the absolute maximum ratings of the transceiver. These resistances must be less than 10 Ω so that the RS-485 signal is not overly attenuated.

13.2 Layout Example

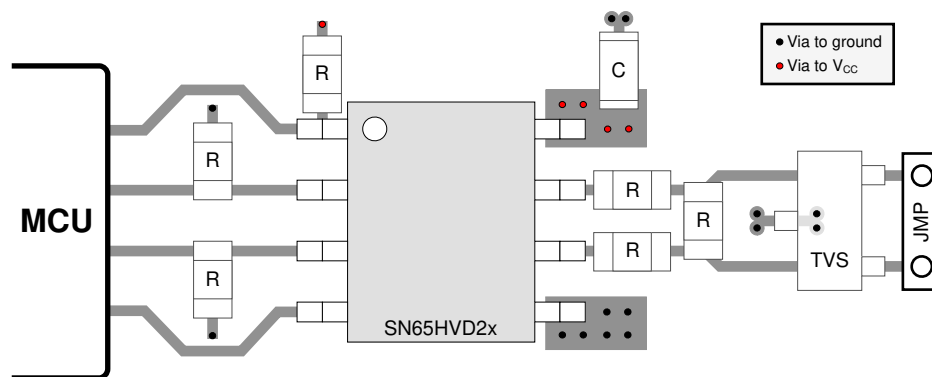

Figure 13-1. SN65HVD2x Layout Example

14 Device and Documentation Support

14.1 Receiving Notification of Documentation Updates

To receive notification of documentation updates, navigate to the device product folder on ti.com. In the upper right corner, click on *Alert me* to register and receive a weekly digest of any product information that has changed. For change details, review the revision history included in any revised document.

14.2 Support Resources

TI E2E™ [support forums](#) are an engineer's go-to source for fast, verified answers and design help — straight from the experts. Search existing answers or ask your own question to get the quick design help you need.

Linked content is provided "AS IS" by the respective contributors. They do not constitute TI specifications and do not necessarily reflect TI's views; see TI's [Terms of Use](#).

14.3 Trademarks

TI E2E™ is a trademark of Texas Instruments.
All trademarks are the property of their respective owners.

14.4 Electrostatic Discharge Caution



This integrated circuit can be damaged by ESD. Texas Instruments recommends that all integrated circuits be handled with appropriate precautions. Failure to observe proper handling and installation procedures can cause damage.

ESD damage can range from subtle performance degradation to complete device failure. Precision integrated circuits may be more susceptible to damage because very small parametric changes could cause the device not to meet its published specifications.

14.5 Glossary

[TI Glossary](#) This glossary lists and explains terms, acronyms, and definitions.

15 Mechanical, Packaging, and Orderable Information

The following pages include mechanical, packaging, and orderable information. This information is the most current data available for the designated devices. This data is subject to change without notice and revision of this document. For browser-based versions of this data sheet, refer to the left-hand navigation.

PACKAGING INFORMATION

Orderable Device	Status (1)	Package Type	Package Drawing	Pins	Package Qty	Eco Plan (2)	Lead finish/ Ball material (6)	MSL Peak Temp (3)	Op Temp (°C)	Device Marking (4/5)	Samples
SN65HVD20DR	ACTIVE	SOIC	D	8	2500	RoHS & Green	NIPDAU	Level-1-260C-UNLIM	-40 to 85	VP20	Samples
SN65HVD20P	ACTIVE	PDIP	P	8	50	RoHS & Green	NIPDAU	N / A for Pkg Type	-40 to 85	65HVD20	Samples
SN65HVD21DR	ACTIVE	SOIC	D	8	2500	RoHS & Green	NIPDAU	Level-1-260C-UNLIM	-40 to 85	VP21	Samples
SN65HVD21P	ACTIVE	PDIP	P	8	50	RoHS & Green	NIPDAU	N / A for Pkg Type	-40 to 85	65HVD21	Samples
SN65HVD22DR	ACTIVE	SOIC	D	8	2500	RoHS & Green	NIPDAU	Level-1-260C-UNLIM	-40 to 85	VP22	Samples
SN65HVD22DRG4	ACTIVE	SOIC	D	8	2500	RoHS & Green	NIPDAU	Level-1-260C-UNLIM	-40 to 85	VP22	Samples
SN65HVD22P	ACTIVE	PDIP	P	8	50	RoHS & Green	NIPDAU	N / A for Pkg Type	-40 to 85	65HVD22	Samples
SN65HVD23DR	ACTIVE	SOIC	D	8	2500	RoHS & Green	NIPDAU	Level-1-260C-UNLIM	-40 to 85	VP23	Samples
SN65HVD23P	ACTIVE	PDIP	P	8	50	RoHS & Green	NIPDAU	N / A for Pkg Type	-40 to 85	65HVD23	Samples
SN65HVD24DR	ACTIVE	SOIC	D	8	2500	RoHS & Green	NIPDAU	Level-1-260C-UNLIM	-40 to 85	VP24	Samples

(1) The marketing status values are defined as follows:

ACTIVE: Product device recommended for new designs.

LIFEBUY: TI has announced that the device will be discontinued, and a lifetime-buy period is in effect.

NRND: Not recommended for new designs. Device is in production to support existing customers, but TI does not recommend using this part in a new design.

PREVIEW: Device has been announced but is not in production. Samples may or may not be available.

OBSOLETE: TI has discontinued the production of the device.

(2) **RoHS:** TI defines "RoHS" to mean semiconductor products that are compliant with the current EU RoHS requirements for all 10 RoHS substances, including the requirement that RoHS substance do not exceed 0.1% by weight in homogeneous materials. Where designed to be soldered at high temperatures, "RoHS" products are suitable for use in specified lead-free processes. TI may reference these types of products as "Pb-Free".

RoHS Exempt: TI defines "RoHS Exempt" to mean products that contain lead but are compliant with EU RoHS pursuant to a specific EU RoHS exemption.

Green: TI defines "Green" to mean the content of Chlorine (Cl) and Bromine (Br) based flame retardants meet JS709B low halogen requirements of <=1000ppm threshold. Antimony trioxide based flame retardants must also meet the <=1000ppm threshold requirement.

(3) MSL, Peak Temp. - The Moisture Sensitivity Level rating according to the JEDEC industry standard classifications, and peak solder temperature.

(4) There may be additional marking, which relates to the logo, the lot trace code information, or the environmental category on the device.

⁽⁵⁾ Multiple Device Markings will be inside parentheses. Only one Device Marking contained in parentheses and separated by a "~" will appear on a device. If a line is indented then it is a continuation of the previous line and the two combined represent the entire Device Marking for that device.

⁽⁶⁾ Lead finish/Ball material - Orderable Devices may have multiple material finish options. Finish options are separated by a vertical ruled line. Lead finish/Ball material values may wrap to two lines if the finish value exceeds the maximum column width.

Important Information and Disclaimer:The information provided on this page represents TI's knowledge and belief as of the date that it is provided. TI bases its knowledge and belief on information provided by third parties, and makes no representation or warranty as to the accuracy of such information. Efforts are underway to better integrate information from third parties. TI has taken and continues to take reasonable steps to provide representative and accurate information but may not have conducted destructive testing or chemical analysis on incoming materials and chemicals. TI and TI suppliers consider certain information to be proprietary, and thus CAS numbers and other limited information may not be available for release.

In no event shall TI's liability arising out of such information exceed the total purchase price of the TI part(s) at issue in this document sold by TI to Customer on an annual basis.

TAPE AND REEL INFORMATION

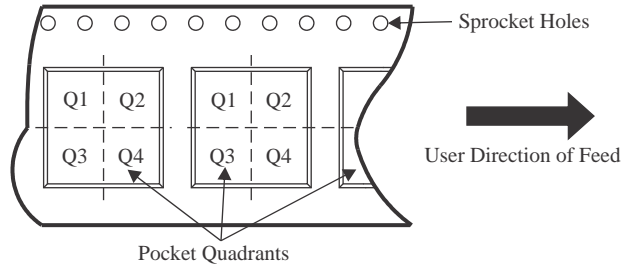
QUADRANT ASSIGNMENTS FOR PIN 1 ORIENTATION IN TAPE

*All dimensions are nominal

Device	Package Type	Package Drawing	Pins	SPQ	Reel Diameter (mm)	Reel Width W1 (mm)	A0 (mm)	B0 (mm)	K0 (mm)	P1 (mm)	W (mm)	Pin1 Quadrant
SN65HVD20DR	SOIC	D	8	2500	330.0	12.4	6.4	5.2	2.1	8.0	12.0	Q1
SN65HVD21DR	SOIC	D	8	2500	330.0	12.4	6.4	5.2	2.1	8.0	12.0	Q1
SN65HVD22DR	SOIC	D	8	2500	330.0	12.4	6.4	5.2	2.1	8.0	12.0	Q1
SN65HVD23DR	SOIC	D	8	2500	330.0	12.4	6.4	5.2	2.1	8.0	12.0	Q1
SN65HVD24DR	SOIC	D	8	2500	330.0	12.4	6.4	5.2	2.1	8.0	12.0	Q1

TAPE AND REEL BOX DIMENSIONS

*All dimensions are nominal

Device	Package Type	Package Drawing	Pins	SPQ	Length (mm)	Width (mm)	Height (mm)
SN65HVD20DR	SOIC	D	8	2500	367.0	367.0	35.0
SN65HVD21DR	SOIC	D	8	2500	367.0	367.0	35.0
SN65HVD22DR	SOIC	D	8	2500	367.0	367.0	35.0
SN65HVD23DR	SOIC	D	8	2500	367.0	367.0	35.0
SN65HVD24DR	SOIC	D	8	2500	367.0	367.0	35.0

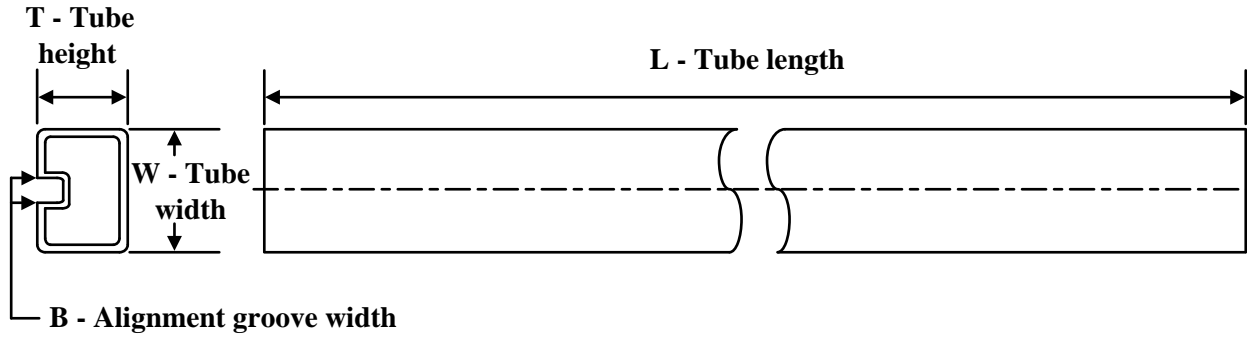
TUBE

*All dimensions are nominal

Device	Package Name	Package Type	Pins	SPQ	L (mm)	W (mm)	T (μm)	B (mm)
SN65HVD20P	P	PDIP	8	50	506	13.97	11230	4.32
SN65HVD21P	P	PDIP	8	50	506	13.97	11230	4.32
SN65HVD22P	P	PDIP	8	50	506	13.97	11230	4.32
SN65HVD23P	P	PDIP	8	50	506	13.97	11230	4.32



D0008A

PACKAGE OUTLINE

SOIC - 1.75 mm max height

SMALL OUTLINE INTEGRATED CIRCUIT



4214825/C 02/2019

NOTES:

1. Linear dimensions are in inches [millimeters]. Dimensions in parenthesis are for reference only. Controlling dimensions are in inches. Dimensioning and tolerancing per ASME Y14.5M.
2. This drawing is subject to change without notice.
3. This dimension does not include mold flash, protrusions, or gate burrs. Mold flash, protrusions, or gate burrs shall not exceed $.006$ [0.15] per side.
4. This dimension does not include interlead flash.
5. Reference JEDEC registration MS-012, variation AA.

EXAMPLE BOARD LAYOUT

D0008A

SOIC - 1.75 mm max height

SMALL OUTLINE INTEGRATED CIRCUIT



LAND PATTERN EXAMPLE
 EXPOSED METAL SHOWN
 SCALE:8X



SOLDER MASK DETAILS

4214825/C 02/2019

NOTES: (continued)

- 6. Publication IPC-7351 may have alternate designs.
- 7. Solder mask tolerances between and around signal pads can vary based on board fabrication site.

EXAMPLE STENCIL DESIGN

D0008A

SOIC - 1.75 mm max height

SMALL OUTLINE INTEGRATED CIRCUIT



SOLDER PASTE EXAMPLE
BASED ON .005 INCH [0.125 MM] THICK STENCIL
SCALE:8X

4214825/C 02/2019

NOTES: (continued)

8. Laser cutting apertures with trapezoidal walls and rounded corners may offer better paste release. IPC-7525 may have alternate design recommendations.
9. Board assembly site may have different recommendations for stencil design.

P (R-PDIP-T8)

PLASTIC DUAL-IN-LINE PACKAGE



- NOTES:
- A. All linear dimensions are in inches (millimeters).
 - B. This drawing is subject to change without notice.
 - C. Falls within JEDEC MS-001 variation BA.

IMPORTANT NOTICE AND DISCLAIMER

TI PROVIDES TECHNICAL AND RELIABILITY DATA (INCLUDING DATA SHEETS), DESIGN RESOURCES (INCLUDING REFERENCE DESIGNS), APPLICATION OR OTHER DESIGN ADVICE, WEB TOOLS, SAFETY INFORMATION, AND OTHER RESOURCES "AS IS" AND WITH ALL FAULTS, AND DISCLAIMS ALL WARRANTIES, EXPRESS AND IMPLIED, INCLUDING WITHOUT LIMITATION ANY IMPLIED WARRANTIES OF MERCHANTABILITY, FITNESS FOR A PARTICULAR PURPOSE OR NON-INFRINGEMENT OF THIRD PARTY INTELLECTUAL PROPERTY RIGHTS.

These resources are intended for skilled developers designing with TI products. You are solely responsible for (1) selecting the appropriate TI products for your application, (2) designing, validating and testing your application, and (3) ensuring your application meets applicable standards, and any other safety, security, regulatory or other requirements.

These resources are subject to change without notice. TI grants you permission to use these resources only for development of an application that uses the TI products described in the resource. Other reproduction and display of these resources is prohibited. No license is granted to any other TI intellectual property right or to any third party intellectual property right. TI disclaims responsibility for, and you will fully indemnify TI and its representatives against, any claims, damages, costs, losses, and liabilities arising out of your use of these resources.

TI's products are provided subject to [TI's Terms of Sale](#) or other applicable terms available either on [ti.com](https://www.ti.com) or provided in conjunction with such TI products. TI's provision of these resources does not expand or otherwise alter TI's applicable warranties or warranty disclaimers for TI products.

TI objects to and rejects any additional or different terms you may have proposed.

Mailing Address: Texas Instruments, Post Office Box 655303, Dallas, Texas 75265
Copyright © 2024, Texas Instruments Incorporated

Looking for pricing, stock, or lifecycle information?

Click below to explore more details on WIN SOURCE:

 [View SN65HVD23DRG4 on WIN SOURCE](#)

 [Texas Instruments](#) Information

Optimize Your Supply Chain with WIN SOURCE Solutions

-  Global Sourcing Solution
-  Obsolete Management
-  Cost Control Management
-  Shortage Management
-  Alternative Solution
-  Excess Inventory Management