



**THE DATASHEET OF  
SN74ALS541DW**



# SN54ALS541, SN74ALS540, SN74ALS541 OCTAL BUFFERS AND LINE DRIVERS WITH 3-STATE OUTPUTS

SDAS025D – APRIL 1982 – REVISED MARCH 2002

- 3-State Outputs Drive Bus Lines or Buffer Memory Address Registers
- pnp Inputs Reduce dc Loading
- Data Flowthrough Pinout (All Inputs on Opposite Side From Outputs)

## description

These octal buffers and line drivers are designed to have the performance of the popular SN54ALS240A/SN74ALS240A series and, at the same time, offer a pinout with inputs and outputs on opposite sides of the package. This arrangement greatly facilitates printed circuit board layout.

The 3-state control gate is a 2-input NOR gate such that, if either output-enable ( $\overline{OE1}$  or  $\overline{OE2}$ ) input is high, all eight outputs are in the high-impedance state.

The SN74ALS540 provides inverted data. The 'ALS541 provide true data at the outputs.

The -1 versions of SN74ALS540 and SN74ALS541 are identical to the standard versions, except that the recommended maximum  $I_{OL}$  is increased to 48 mA. There is no -1 version of the SN54ALS541.

SN54ALS541 . . . J PACKAGE  
SN74ALS540 . . . DW, N, OR NS PACKAGE  
SN74ALS541 . . . DB, DW, N, OR NS PACKAGE  
(TOP VIEW)

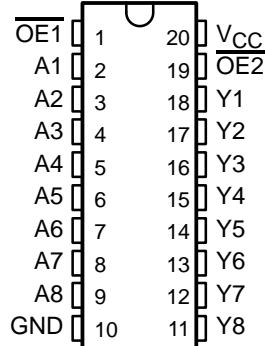

SN54ALS541 . . . FK PACKAGE  
(TOP VIEW)

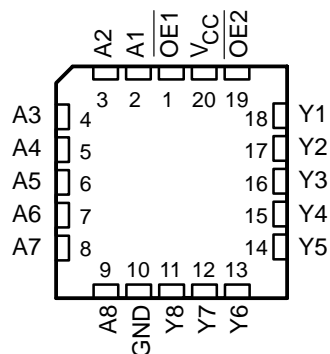

Please be aware that an important notice concerning availability, standard warranty, and use in critical applications of Texas Instruments semiconductor products and disclaimers thereto appears at the end of this data sheet.

PRODUCTION DATA information is current as of publication date. Products conform to specifications per the terms of Texas Instruments standard warranty. Production processing does not necessarily include testing of all parameters.

 **TEXAS  
INSTRUMENTS**

POST OFFICE BOX 655303 • DALLAS, TEXAS 75265

Copyright © 2002, Texas Instruments Incorporated  
On products compliant to MIL-PRF-38535, all parameters are tested unless otherwise noted. On all other products, production processing does not necessarily include testing of all parameters.

# SN54ALS541, SN74ALS540, SN74ALS541 OCTAL BUFFERS AND LINE DRIVERS WITH 3-STATE OUTPUTS

SDAS025D – APRIL 1982 – REVISED MARCH 2002

## ORDERING INFORMATION

| T <sub>A</sub>  | PACKAGE†  |               | ORDERABLE PART NUMBER | TOP-SIDE MARKING |
|-----------------|-----------|---------------|-----------------------|------------------|
| 0°C to 70°C     | PDIP – N  | Tube          | SN74ALS540N           | SN74ALS540N      |
|                 |           |               | SN74ALS540-1N         | SN74ALS540-1N    |
|                 |           |               | SN74ALS541N           | SN74ALS541N      |
|                 |           |               | SN74ALS541-1N         | SN74ALS541-1N    |
|                 | SOIC – DW | Tube          | SN74ALS540DW          | ALS540           |
|                 |           | Tape and reel | SN74ALS540DWR         |                  |
|                 |           | Tube          | SN74ALS540-1DW        | ALS540-1         |
|                 |           | Tube          | SN74ALS541DW          |                  |
|                 |           | Tape and reel | SN74ALS541DWR         | ALS541           |
|                 |           | Tube          | SN74ALS541-1DW        |                  |
|                 | SOP – NS  | Tape and reel | SN74ALS540NSR         | ALS540           |
|                 |           |               | SN74ALS540-1NSR       | ALS540-1         |
|                 |           |               | SN74ALS541NSR         | ALS541           |
|                 | SSOP – DB | Tape and reel | SN74ALS541DBR         | G541             |
| SN74ALS541-1DBR |           |               | G541-1                |                  |
| –55°C to 125°C  | CDIP – J  | Tube          | SNJ54ALS541J          | SNJ54ALS541J     |
|                 | LCCC – FK | Tube          | SNJ54ALS541FK         | SNJ54ALS541FK    |

† Package drawings, standard packing quantities, thermal data, symbolization, and PCB design guidelines are available at [www.ti.com/sc/package](http://www.ti.com/sc/package).

## logic diagrams (positive logic)

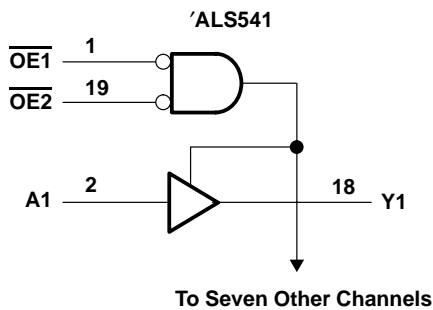
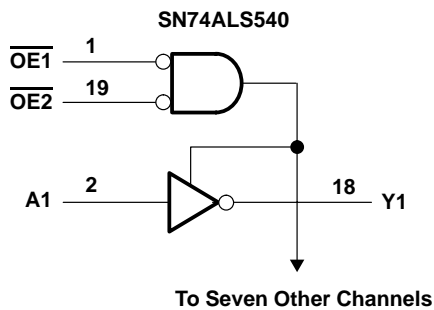

# SN54ALS541, SN74ALS540, SN74ALS541 OCTAL BUFFERS AND LINE DRIVERS WITH 3-STATE OUTPUTS

SDAS025D – APRIL 1982 – REVISED MARCH 2002

## absolute maximum ratings over operating free-air temperature (unless otherwise noted)†

|   |                |
|---|----------------|
| Supply voltage, $V_{CC}$ .....  | 7 V            |
| Input voltage, $V_I$ .....  | 7 V            |
| Voltage applied to a disabled 3-state output .....                      | 5.5 V          |
| Package thermal impedance, $\theta_{JA}$ (see Note 1): DB package ..... | 70°C/W         |
| DW package .....  | 58°C/W         |
| N package .....   | 69°C/W         |
| NS package .....  | 60°C/W         |
| Storage temperature range, $T_{stg}$ .....                              | –65°C to 150°C |

† Stresses beyond those listed under “absolute maximum ratings” may cause permanent damage to the device. These are stress ratings only, and functional operation of the device at these or any other conditions beyond those indicated under “recommended operating conditions” is not implied. Exposure to absolute-maximum-rated conditions for extended periods may affect device reliability.

NOTE 1: The package thermal impedance is calculated in accordance with JESD 51-7.

## recommended operating conditions

|          |                                | SN54ALS541 |     |     | SN74ALS540<br>SN74ALS541 |     |     | UNIT |
|----------|--------------------------------|------------|-----|-----|--------------------------|-----|-----|------|
|          |                                | MIN        | NOM | MAX | MIN                      | NOM | MAX |      |
| $V_{CC}$ | Supply voltage                 | 4.5        | 5   | 5.5 | 4.5                      | 5   | 5.5 | V    |
| $V_{IH}$ | High-level input voltage       | 2          |     |     | 2                        |     |     | V    |
| $V_{IL}$ | Low-level input voltage        |            |     | 0.7 |                          |     | 0.8 | V    |
| $I_{OH}$ | High-level output current      |            |     | –12 |                          |     | –15 | mA   |
| $I_{OL}$ | Low-level output current       |            |     | 12  |                          |     | 24  | mA   |
|          |                                |            |     |     |                          |     | 48† |      |
| $T_A$    | Operating free-air temperature | –55        |     | 125 | 0                        |     | 70  | °C   |

† Applies only to the -1 version and only if  $V_{CC}$  is between 4.75 V and 5.25 V



# SN54ALS541, SN74ALS540, SN74ALS541

## OCTAL BUFFERS AND LINE DRIVERS

### WITH 3-STATE OUTPUTS

SDAS025D – APRIL 1982 – REVISED MARCH 2002

electrical characteristics over recommended operating free-air temperature range (unless otherwise noted)

| PARAMETER                   | TEST CONDITIONS   |                                      | SN54ALS541          |                  |          | SN74ALS540<br>SN74ALS541 |                  |     | UNIT |
|-----------------------------|---|--------------------------------------|---------------------|------------------|----------|--------------------------|------------------|-----|------|
|                             |   |                                      | MIN                 | TYP <sup>‡</sup> | MAX      | MIN                      | TYP <sup>‡</sup> | MAX |      |
| V <sub>IK</sub>             | V <sub>CC</sub> = 4.5 V, I <sub>I</sub> = -18 mA            |                                      | -1.2                |                  |          | -1.2                     |                  |     | V    |
| V <sub>OH</sub>             | V <sub>CC</sub> = 4.5 V to 5.5 V, I <sub>OH</sub> = -0.4 mA |                                      | V <sub>CC</sub> - 2 |                  |          | V <sub>CC</sub> - 2      |                  |     | V    |
|                             | V <sub>CC</sub> = 4.5 V                                     | I <sub>OH</sub> = -3 mA              | 2.4                 | 3.2              | 2.4      | 3.2                      |                  |     |      |
|                             |   | I <sub>OH</sub> = -12 mA             | 2                   |                  | 2        |                          |                  |     |      |
| V <sub>OL</sub>             | V <sub>CC</sub> = 4.5 V                                     | I <sub>OL</sub> = 12 mA              | 0.25 0.4            |                  | 0.25 0.4 |                          |                  |     |      |
|                             |   | I <sub>OL</sub> = 24 mA              |                     |                  | 0.35 0.5 |                          |                  |     |      |
|                             |   | I <sub>OL</sub> = 48 mA <sup>†</sup> |                     |                  | 0.35 0.5 |                          |                  |     |      |
| I <sub>OZH</sub>            | V <sub>CC</sub> = 5.5 V, V <sub>O</sub> = 2.7 V             | 20                                   |                     |                  | 20       |                          |                  | μA  |      |
| I <sub>OZL</sub>            | V <sub>CC</sub> = 5.5 V, V <sub>O</sub> = 0.4 V             | -20                                  |                     |                  | -20      |                          |                  | μA  |      |
| I <sub>I</sub>              | V <sub>CC</sub> = 5.5 V, V <sub>I</sub> = 7 V               | 0.1                                  |                     |                  | 0.1      |                          |                  | mA  |      |
| I <sub>IH</sub>             | V <sub>CC</sub> = 5.5 V, V <sub>I</sub> = 2.7 V             | 20                                   |                     |                  | 20       |                          |                  | μA  |      |
| I <sub>IL</sub>             | V <sub>CC</sub> = 5.5 V, V <sub>I</sub> = 0.4 V             | -0.2                                 |                     |                  | -0.1     |                          |                  | mA  |      |
| I <sub>O</sub> <sup>§</sup> | V <sub>CC</sub> = 5.5 V, V <sub>O</sub> = 2.25 V            | -20                                  | -112                |                  | -30      | -112                     |                  | mA  |      |
| I <sub>CC</sub>             | SN74ALS540  | V <sub>CC</sub> = 5.5 V              | Outputs high        |                  | 5 10     |                          |                  |     |      |
|                             |   |                                      | Outputs low         |                  | 13 22    |                          |                  |     |      |
|                             |   |                                      | Outputs disabled    |                  | 11 19    |                          |                  |     |      |
|                             | 'ALS541   | V <sub>CC</sub> = 5.5 V              | Outputs high        |                  | 6        | 14                       | 6                | 14  |      |
|                             |   |                                      | Outputs low         |                  | 15       | 25                       | 15               | 25  |      |
|                             |   |                                      | Outputs disabled    |                  | 13.5     | 32                       | 13.5             | 22  |      |

<sup>†</sup> Applies only to the -1 version and only if V<sub>CC</sub> is between 4.75 V and 5.25 V

<sup>‡</sup> All typical values are at V<sub>CC</sub> = 5 V, T<sub>A</sub> = 25°C.

<sup>§</sup> The output conditions have been chosen to produce a current that closely approximates one-half of the true short-circuit output current, I<sub>OS</sub>.

### switching characteristics (see Figure 1)

| PARAMETER        | FROM<br>(INPUT) | TO<br>(OUTPUT) | V <sub>CC</sub> = 4.5 V to 5.5 V,<br>C <sub>L</sub> = 50 pF,<br>R <sub>1</sub> = 500 Ω,<br>R <sub>2</sub> = 500 Ω,<br>T <sub>A</sub> = MIN to MAX <sup>†</sup> |     |            |     |            |     | UNIT |
|------------------|-----------------|----------------|--|-----|------------|-----|------------|-----|------|
|                  |                 |                | SN54ALS541   |     | SN74ALS540 |     | SN74ALS541 |     |      |
|                  |                 |                | MIN  | MAX | MIN        | MAX | MIN        | MAX |      |
| t <sub>PLH</sub> | A               | Y              | 4  | 17  | 2          | 12  | 4          | 14  | ns   |
| t <sub>PHL</sub> |                 |                | 2  | 14  | 2          | 9   | 2          | 10  |      |
| t <sub>PZH</sub> | $\overline{OE}$ | Y              | 5  | 18  | 5          | 15  | 5          | 15  | ns   |
| t <sub>PZL</sub> |                 |                | 8  | 28  | 8          | 20  | 8          | 20  |      |
| t <sub>PHZ</sub> | $\overline{OE}$ | Y              | 1  | 12  | 1          | 10  | 1          | 10  | ns   |
| t <sub>PLZ</sub> |                 |                | 2  | 14  | 2          | 12  | 2          | 12  |      |

<sup>†</sup> For conditions shown as MIN or MAX, use the appropriate value specified under recommended operating conditions.



PARAMETER MEASUREMENT INFORMATION  
 SERIES 54ALS/74ALS AND 54AS/74AS DEVICES

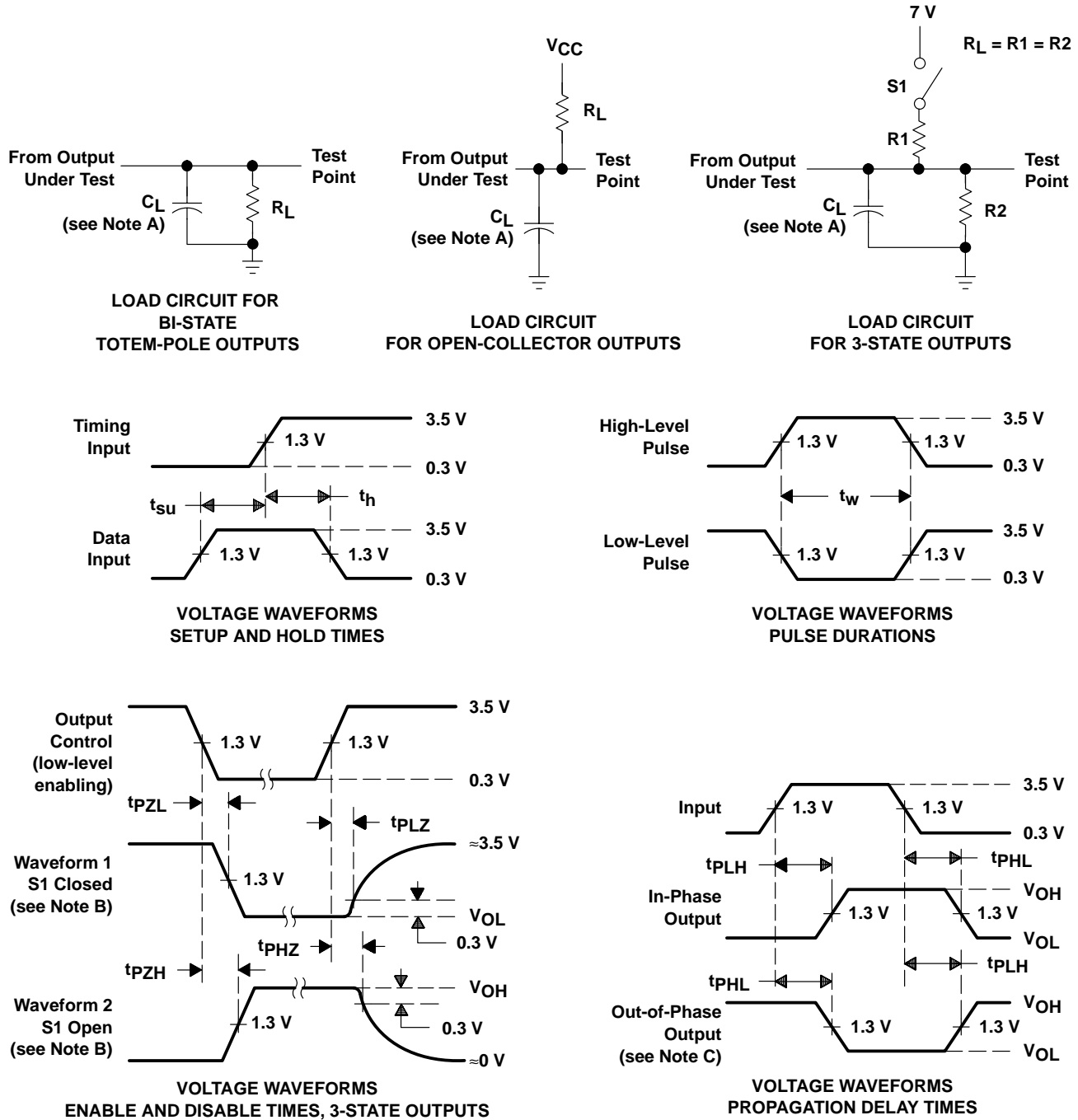

- NOTES: A.  $C_L$  includes probe and jig capacitance.  
 B. Waveform 1 is for an output with internal conditions such that the output is low except when disabled by the output control. Waveform 2 is for an output with internal conditions such that the output is high except when disabled by the output control.  
 C. When measuring propagation delay items of 3-state outputs, switch S1 is open.  
 D. All input pulses have the following characteristics:  $PRR \leq 1$  MHz,  $t_r = t_f = 2$  ns, duty cycle = 50%.  
 E. The outputs are measured one at a time with one transition per measurement.

Figure 1. Load Circuits and Voltage Waveforms

**PACKAGING INFORMATION**

| Orderable Device | Status<br>(1) | Package Type | Package Drawing | Pins | Package Qty | Eco Plan<br>(2)  | Lead finish/<br>Ball material<br>(6) | MSL Peak Temp<br>(3) | Op Temp (°C) | Device Marking<br>(4/5)        | Samples                 |
|------------------|---------------|--------------|-----------------|------|-------------|------------------|--------------------------------------|----------------------|--------------|--------------------------------|-------------------------|
| 5962-8960201RA   | ACTIVE        | CDIP         | J               | 20   | 20          | Non-RoHS & Green | SNPB                                 | N / A for Pkg Type   | -55 to 125   | 5962-8960201RA<br>SNJ54ALS541J | <a href="#">Samples</a> |
| SN54ALS541J      | ACTIVE        | CDIP         | J               | 20   | 20          | Non-RoHS & Green | SNPB                                 | N / A for Pkg Type   | -55 to 125   | SN54ALS541J                    | <a href="#">Samples</a> |
| SN74ALS540-1N    | ACTIVE        | PDIP         | N               | 20   | 20          | RoHS & Green     | NIPDAU                               | N / A for Pkg Type   | 0 to 70      | SN74ALS540-1N                  | <a href="#">Samples</a> |
| SN74ALS540-1NSR  | ACTIVE        | SO           | NS              | 20   | 2000        | RoHS & Green     | NIPDAU                               | Level-1-260C-UNLIM   | 0 to 70      | ALS540-1                       | <a href="#">Samples</a> |
| SN74ALS540DWR    | ACTIVE        | SOIC         | DW              | 20   | 2000        | RoHS & Green     | NIPDAU                               | Level-1-260C-UNLIM   | 0 to 70      | ALS540                         | <a href="#">Samples</a> |
| SN74ALS540N      | ACTIVE        | PDIP         | N               | 20   | 20          | RoHS & Non-Green | NIPDAU                               | N / A for Pkg Type   | 0 to 70      | SN74ALS540N                    | <a href="#">Samples</a> |
| SN74ALS540NSR    | ACTIVE        | SO           | NS              | 20   | 2000        | RoHS & Green     | NIPDAU                               | Level-1-260C-UNLIM   | 0 to 70      | ALS540                         | <a href="#">Samples</a> |
| SN74ALS541-1DW   | ACTIVE        | SOIC         | DW              | 20   | 25          | RoHS & Green     | NIPDAU                               | Level-1-260C-UNLIM   | 0 to 70      | ALS541-1                       | <a href="#">Samples</a> |
| SN74ALS541-1N    | ACTIVE        | PDIP         | N               | 20   | 20          | RoHS & Non-Green | NIPDAU                               | N / A for Pkg Type   | 0 to 70      | SN74ALS541-1N                  | <a href="#">Samples</a> |
| SN74ALS541-1NE4  | ACTIVE        | PDIP         | N               | 20   | 20          | RoHS & Non-Green | NIPDAU                               | N / A for Pkg Type   | 0 to 70      | SN74ALS541-1N                  | <a href="#">Samples</a> |
| SN74ALS541-1NSR  | ACTIVE        | SO           | NS              | 20   | 2000        | RoHS & Green     | NIPDAU                               | Level-1-260C-UNLIM   | 0 to 70      | ALS541-1                       | <a href="#">Samples</a> |
| SN74ALS541DBR    | ACTIVE        | SSOP         | DB              | 20   | 2000        | RoHS & Green     | NIPDAU                               | Level-1-260C-UNLIM   | 0 to 70      | G541                           | <a href="#">Samples</a> |
| SN74ALS541DWR    | ACTIVE        | SOIC         | DW              | 20   | 2000        | RoHS & Green     | NIPDAU                               | Level-1-260C-UNLIM   | 0 to 70      | ALS541                         | <a href="#">Samples</a> |
| SN74ALS541N      | ACTIVE        | PDIP         | N               | 20   | 20          | RoHS & Green     | NIPDAU                               | N / A for Pkg Type   | 0 to 70      | SN74ALS541N                    | <a href="#">Samples</a> |
| SN74ALS541NSR    | ACTIVE        | SO           | NS              | 20   | 2000        | RoHS & Green     | NIPDAU                               | Level-1-260C-UNLIM   | 0 to 70      | ALS541                         | <a href="#">Samples</a> |
| SN74ALS541NSRE4  | ACTIVE        | SO           | NS              | 20   | 2000        | RoHS & Green     | NIPDAU                               | Level-1-260C-UNLIM   | 0 to 70      | ALS541                         | <a href="#">Samples</a> |
| SNJ54ALS541J     | ACTIVE        | CDIP         | J               | 20   | 20          | Non-RoHS & Green | SNPB                                 | N / A for Pkg Type   | -55 to 125   | 5962-8960201RA<br>SNJ54ALS541J | <a href="#">Samples</a> |

(1) The marketing status values are defined as follows:

**ACTIVE:** Product device recommended for new designs.

**LIFEBUY:** TI has announced that the device will be discontinued, and a lifetime-buy period is in effect.

**NRND:** Not recommended for new designs. Device is in production to support existing customers, but TI does not recommend using this part in a new design.

**PREVIEW:** Device has been announced but is not in production. Samples may or may not be available.

**OBSOLETE:** TI has discontinued the production of the device.

<sup>(2)</sup> **RoHS:** TI defines "RoHS" to mean semiconductor products that are compliant with the current EU RoHS requirements for all 10 RoHS substances, including the requirement that RoHS substance do not exceed 0.1% by weight in homogeneous materials. Where designed to be soldered at high temperatures, "RoHS" products are suitable for use in specified lead-free processes. TI may reference these types of products as "Pb-Free".

**RoHS Exempt:** TI defines "RoHS Exempt" to mean products that contain lead but are compliant with EU RoHS pursuant to a specific EU RoHS exemption.

**Green:** TI defines "Green" to mean the content of Chlorine (Cl) and Bromine (Br) based flame retardants meet JS709B low halogen requirements of  $\leq 1000$ ppm threshold. Antimony trioxide based flame retardants must also meet the  $\leq 1000$ ppm threshold requirement.

<sup>(3)</sup> **MSL, Peak Temp.** - The Moisture Sensitivity Level rating according to the JEDEC industry standard classifications, and peak solder temperature.

<sup>(4)</sup> There may be additional marking, which relates to the logo, the lot trace code information, or the environmental category on the device.

<sup>(5)</sup> Multiple Device Markings will be inside parentheses. Only one Device Marking contained in parentheses and separated by a "~" will appear on a device. If a line is indented then it is a continuation of the previous line and the two combined represent the entire Device Marking for that device.

<sup>(6)</sup> **Lead finish/Ball material** - Orderable Devices may have multiple material finish options. Finish options are separated by a vertical ruled line. Lead finish/Ball material values may wrap to two lines if the finish value exceeds the maximum column width.

**Important Information and Disclaimer:** The information provided on this page represents TI's knowledge and belief as of the date that it is provided. TI bases its knowledge and belief on information provided by third parties, and makes no representation or warranty as to the accuracy of such information. Efforts are underway to better integrate information from third parties. TI has taken and continues to take reasonable steps to provide representative and accurate information but may not have conducted destructive testing or chemical analysis on incoming materials and chemicals. TI and TI suppliers consider certain information to be proprietary, and thus CAS numbers and other limited information may not be available for release.

In no event shall TI's liability arising out of such information exceed the total purchase price of the TI part(s) at issue in this document sold by TI to Customer on an annual basis.

**OTHER QUALIFIED VERSIONS OF SN54ALS541, SN74ALS541 :**

● Catalog : [SN74ALS541](#)

● Military : [SN54ALS541](#)

NOTE: Qualified Version Definitions:

● Catalog - TI's standard catalog product

- Military - QML certified for Military and Defense Applications

**TAPE AND REEL INFORMATION**

**QUADRANT ASSIGNMENTS FOR PIN 1 ORIENTATION IN TAPE**



\*All dimensions are nominal

| Device          | Package Type | Package Drawing | Pins | SPQ  | Reel Diameter (mm) | Reel Width W1 (mm) | A0 (mm) | B0 (mm) | K0 (mm) | P1 (mm) | W (mm) | Pin1 Quadrant |
|-----------------|--------------|-----------------|------|------|--------------------|--------------------|---------|---------|---------|---------|--------|---------------|
| SN74ALS540-1NSR | SO           | NS              | 20   | 2000 | 330.0              | 24.4               | 8.4     | 13.0    | 2.5     | 12.0    | 24.0   | Q1            |
| SN74ALS540DWR   | SOIC         | DW              | 20   | 2000 | 330.0              | 24.4               | 10.8    | 13.3    | 2.7     | 12.0    | 24.0   | Q1            |
| SN74ALS540NSR   | SO           | NS              | 20   | 2000 | 330.0              | 24.4               | 8.4     | 13.0    | 2.5     | 12.0    | 24.0   | Q1            |
| SN74ALS541-1NSR | SO           | NS              | 20   | 2000 | 330.0              | 24.4               | 8.4     | 13.0    | 2.5     | 12.0    | 24.0   | Q1            |
| SN74ALS541DBR   | SSOP         | DB              | 20   | 2000 | 330.0              | 16.4               | 8.2     | 7.5     | 2.5     | 12.0    | 16.0   | Q1            |
| SN74ALS541DWR   | SOIC         | DW              | 20   | 2000 | 330.0              | 24.4               | 10.8    | 13.3    | 2.7     | 12.0    | 24.0   | Q1            |
| SN74ALS541NSR   | SO           | NS              | 20   | 2000 | 330.0              | 24.4               | 8.4     | 13.0    | 2.5     | 12.0    | 24.0   | Q1            |

**TAPE AND REEL BOX DIMENSIONS**

\*All dimensions are nominal

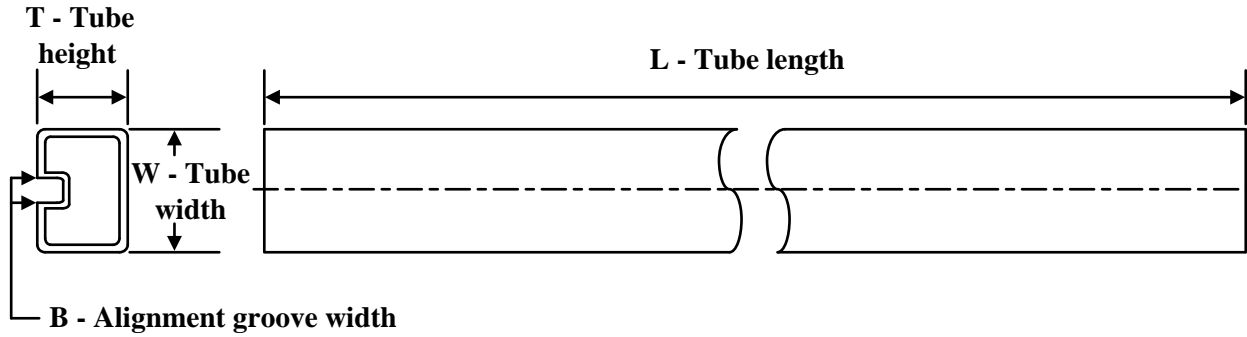
| Device          | Package Type | Package Drawing | Pins | SPQ  | Length (mm) | Width (mm) | Height (mm) |
|-----------------|--------------|-----------------|------|------|-------------|------------|-------------|
| SN74ALS540-1NSR | SO           | NS              | 20   | 2000 | 367.0       | 367.0      | 45.0        |
| SN74ALS540DWR   | SOIC         | DW              | 20   | 2000 | 367.0       | 367.0      | 45.0        |
| SN74ALS540NSR   | SO           | NS              | 20   | 2000 | 367.0       | 367.0      | 45.0        |
| SN74ALS541-1NSR | SO           | NS              | 20   | 2000 | 367.0       | 367.0      | 45.0        |
| SN74ALS541DBR   | SSOP         | DB              | 20   | 2000 | 356.0       | 356.0      | 35.0        |
| SN74ALS541DWR   | SOIC         | DW              | 20   | 2000 | 367.0       | 367.0      | 45.0        |
| SN74ALS541NSR   | SO           | NS              | 20   | 2000 | 367.0       | 367.0      | 45.0        |

**TUBE**

\*All dimensions are nominal

| Device          | Package Name | Package Type | Pins | SPQ | L (mm) | W (mm) | T (μm) | B (mm) |
|-----------------|--------------|--------------|------|-----|--------|--------|--------|--------|
| SN74ALS540-1N   | N            | PDIP         | 20   | 20  | 506    | 13.97  | 11230  | 4.32   |
| SN74ALS540N     | N            | PDIP         | 20   | 20  | 506    | 13.97  | 11230  | 4.32   |
| SN74ALS541-1DW  | DW           | SOIC         | 20   | 25  | 507    | 12.83  | 5080   | 6.6    |
| SN74ALS541-1N   | N            | PDIP         | 20   | 20  | 506    | 13.97  | 11230  | 4.32   |
| SN74ALS541-1NE4 | N            | PDIP         | 20   | 20  | 506    | 13.97  | 11230  | 4.32   |
| SN74ALS541N     | N            | PDIP         | 20   | 20  | 506    | 13.97  | 11230  | 4.32   |

# DB0020A



# PACKAGE OUTLINE

## SSOP - 2 mm max height

SMALL OUTLINE PACKAGE



4214851/B 08/2019

### NOTES:

1. All linear dimensions are in millimeters. Any dimensions in parenthesis are for reference only. Dimensioning and tolerancing per ASME Y14.5M.
2. This drawing is subject to change without notice.
3. This dimension does not include mold flash, protrusions, or gate burrs. Mold flash, protrusions, or gate burrs shall not exceed 0.15 mm per side.
4. This dimension does not include interlead flash. Interlead flash shall not exceed 0.25 mm per side.
5. Reference JEDEC registration MO-150.

# EXAMPLE BOARD LAYOUT

DB0020A

SSOP - 2 mm max height

SMALL OUTLINE PACKAGE



LAND PATTERN EXAMPLE  
EXPOSED METAL SHOWN  
SCALE: 10X

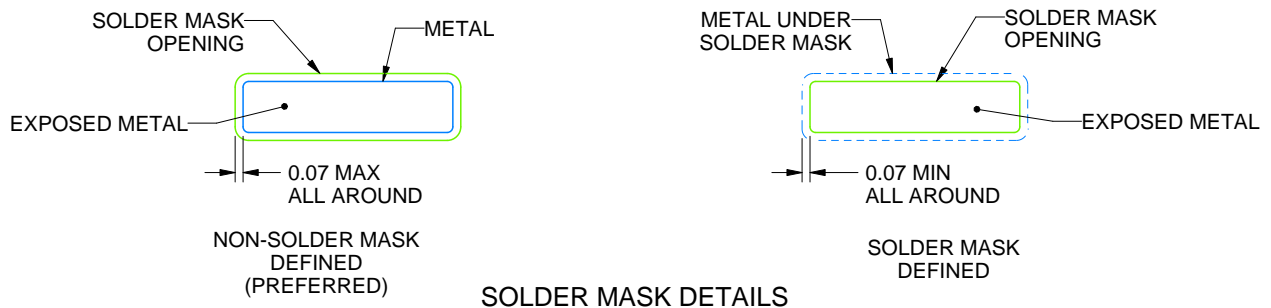

4214851/B 08/2019

NOTES: (continued)

6. Publication IPC-7351 may have alternate designs.
7. Solder mask tolerances between and around signal pads can vary based on board fabrication site.

# EXAMPLE STENCIL DESIGN

DB0020A

SSOP - 2 mm max height

SMALL OUTLINE PACKAGE

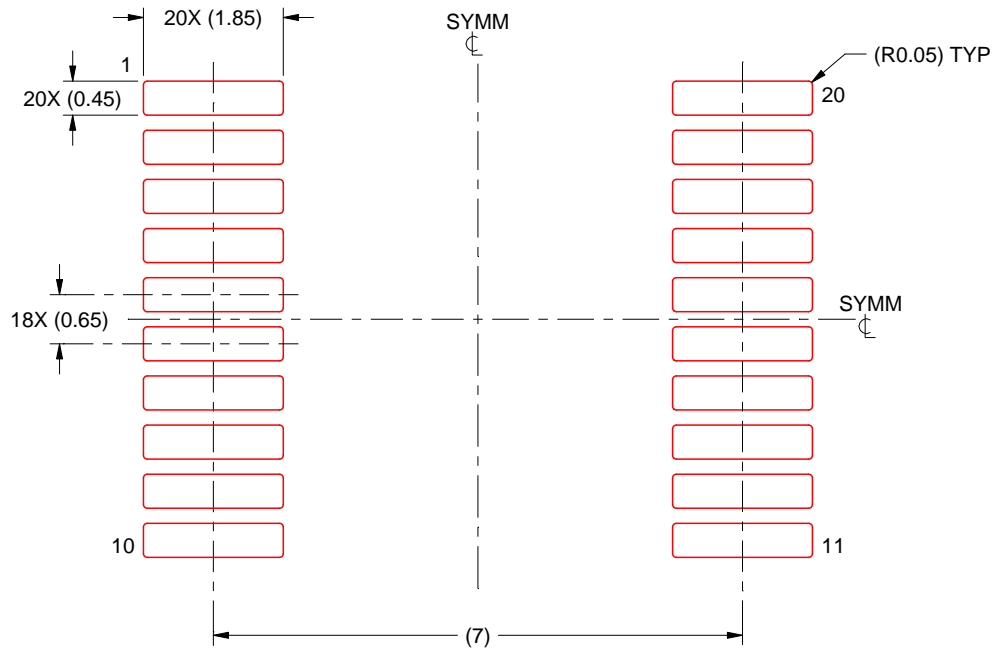

SOLDER PASTE EXAMPLE  
BASED ON 0.125 mm THICK STENCIL  
SCALE: 10X

4214851/B 08/2019

NOTES: (continued)

8. Laser cutting apertures with trapezoidal walls and rounded corners may offer better paste release. IPC-7525 may have alternate design recommendations.
9. Board assembly site may have different recommendations for stencil design.

# MECHANICAL DATA

NS (R-PDSO-G\*\*)

PLASTIC SMALL-OUTLINE PACKAGE

14-PINS SHOWN



- NOTES:
- A. All linear dimensions are in millimeters.
  - B. This drawing is subject to change without notice.
  - C. Body dimensions do not include mold flash or protrusion, not to exceed 0,15.

J (R-GDIP-T\*\*)

14 LEADS SHOWN

CERAMIC DUAL IN-LINE PACKAGE



| DIM \ PINS ** | 14                     | 16                     | 18                     | 20                     |
|---------------|------------------------|------------------------|------------------------|------------------------|
| A             | 0.300<br>(7,62)<br>BSC | 0.300<br>(7,62)<br>BSC | 0.300<br>(7,62)<br>BSC | 0.300<br>(7,62)<br>BSC |
| B MAX         | 0.785<br>(19,94)       | .840<br>(21,34)        | 0.960<br>(24,38)       | 1.060<br>(26,92)       |
| B MIN         | —                      | —                      | —                      | —                      |
| C MAX         | 0.300<br>(7,62)        | 0.300<br>(7,62)        | 0.310<br>(7,87)        | 0.300<br>(7,62)        |
| C MIN         | 0.245<br>(6,22)        | 0.245<br>(6,22)        | 0.220<br>(5,59)        | 0.245<br>(6,22)        |



4040083/F 03/03

- NOTES:
- All linear dimensions are in inches (millimeters).
  - This drawing is subject to change without notice.
  - This package is hermetically sealed with a ceramic lid using glass frit.
  - Index point is provided on cap for terminal identification only on press ceramic glass frit seal only.
  - Falls within MIL STD 1835 GDIP1-T14, GDIP1-T16, GDIP1-T18 and GDIP1-T20.

N (R-PDIP-T\*\*)

PLASTIC DUAL-IN-LINE PACKAGE

16 PINS SHOWN



- NOTES:
- A. All linear dimensions are in inches (millimeters).
  - B. This drawing is subject to change without notice.
  - $\triangle C$  Falls within JEDEC MS-001, except 18 and 20 pin minimum body length (Dim A).
  - $\triangle D$  The 20 pin end lead shoulder width is a vendor option, either half or full width.

# DW0020A



# PACKAGE OUTLINE

## SOIC - 2.65 mm max height

SOIC



4220724/A 05/2016

# EXAMPLE BOARD LAYOUT

DW0020A

SOIC - 2.65 mm max height

SOIC



LAND PATTERN EXAMPLE  
SCALE:6X



SOLDER MASK DETAILS

4220724/A 05/2016

NOTES: (continued)

- 6. Publication IPC-7351 may have alternate designs.
- 7. Solder mask tolerances between and around signal pads can vary based on board fabrication site.

# EXAMPLE STENCIL DESIGN

DW0020A

SOIC - 2.65 mm max height

SOIC



SOLDER PASTE EXAMPLE  
BASED ON 0.125 mm THICK STENCIL  
SCALE:6X

4220724/A 05/2016

NOTES: (continued)

8. Laser cutting apertures with trapezoidal walls and rounded corners may offer better paste release. IPC-7525 may have alternate design recommendations.
9. Board assembly site may have different recommendations for stencil design.

## IMPORTANT NOTICE AND DISCLAIMER

TI PROVIDES TECHNICAL AND RELIABILITY DATA (INCLUDING DATA SHEETS), DESIGN RESOURCES (INCLUDING REFERENCE DESIGNS), APPLICATION OR OTHER DESIGN ADVICE, WEB TOOLS, SAFETY INFORMATION, AND OTHER RESOURCES "AS IS" AND WITH ALL FAULTS, AND DISCLAIMS ALL WARRANTIES, EXPRESS AND IMPLIED, INCLUDING WITHOUT LIMITATION ANY IMPLIED WARRANTIES OF MERCHANTABILITY, FITNESS FOR A PARTICULAR PURPOSE OR NON-INFRINGEMENT OF THIRD PARTY INTELLECTUAL PROPERTY RIGHTS.

These resources are intended for skilled developers designing with TI products. You are solely responsible for (1) selecting the appropriate TI products for your application, (2) designing, validating and testing your application, and (3) ensuring your application meets applicable standards, and any other safety, security, regulatory or other requirements.

These resources are subject to change without notice. TI grants you permission to use these resources only for development of an application that uses the TI products described in the resource. Other reproduction and display of these resources is prohibited. No license is granted to any other TI intellectual property right or to any third party intellectual property right. TI disclaims responsibility for, and you will fully indemnify TI and its representatives against, any claims, damages, costs, losses, and liabilities arising out of your use of these resources.

TI's products are provided subject to [TI's Terms of Sale](#) or other applicable terms available either on [ti.com](https://www.ti.com) or provided in conjunction with such TI products. TI's provision of these resources does not expand or otherwise alter TI's applicable warranties or warranty disclaimers for TI products.

TI objects to and rejects any additional or different terms you may have proposed.

Mailing Address: Texas Instruments, Post Office Box 655303, Dallas, Texas 75265  
Copyright © 2024, Texas Instruments Incorporated

## Looking for pricing, stock, or lifecycle information?

Click below to explore more details on WIN SOURCE:

 [View SN74ALS541DW on WIN SOURCE](#)

 [Texas Instruments](#) Information

## Optimize Your Supply Chain with WIN SOURCE Solutions

-  Global Sourcing Solution
-  Obsolete Management
-  Cost Control Management
-  Shortage Management
-  Alternative Solution
-  Excess Inventory Management