



THE DATASHEET OF OPA606KM





OPA606

Wide-Bandwidth *Difer*[®] OPERATIONAL AMPLIFIER

FEATURES

- WIDE BANDWIDTH: 13MHz typ
- HIGH SLEW RATE: 35V/μs typ
- LOW BIAS CURRENT: 10pA max at $T_A = +25^\circ\text{C}$
- LOW OFFSET VOLTAGE: 500μV max
- LOW DISTORTION: 0.0035% typ at 10kHz

APPLICATIONS

- OPTOELECTONICS
- DATA ACQUISITION
- TEST EQUIPMENT
- AUDIO AMPLIFIERS

DESCRIPTION

The OPA606 is a wide-bandwidth monolithic dielectrically-isolated FET (*Difer*[®]) operational amplifier featuring a wider bandwidth and lower bias current than BIFET[®] LF156A amplifiers. Bias current is specified under warmed-up and operating conditions, as opposed to a junction temperature of +25°C.

Laser-trimmed thin-film resistors offer improved offset voltage and noise performance.

The OPA606 is internally compensated for unity-gain stability.

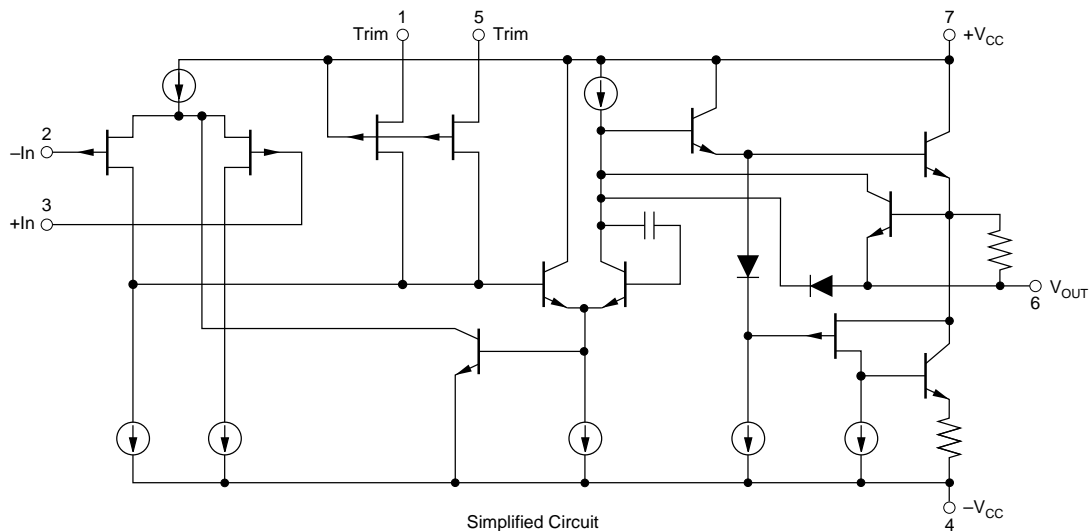

Difer[®]; Burr-Brown Corp.

BIFET[®]; National Semiconductor Corp.

International Airport Industrial Park • Mailing Address: PO Box 11400 • Tucson, AZ 85734 • Street Address: 6730 S. Tucson Blvd. • Tucson, AZ 85706
Tel: (520) 746-1111 • Twx: 910-952-1111 • Cable: BBRCORP • Telex: 066-6491 • FAX: (520) 889-1510 • Immediate Product Info: (800) 548-6132

SPECIFICATIONS

ELECTRICAL

At $V_{CC} = \pm 15\text{VDC}$ and $T_A = +25^\circ\text{C}$ unless otherwise noted.

PARAMETER	CONDITIONS	OPA606KM			OPA606LM			OPA606KP			UNITS
		MIN	TYP	MAX	MIN	TYP	MAX	MIN	TYP	MAX	
FREQUENCY RESPONSE											
Gain Bandwidth	Small Signal	10	12.5		11	13		9	12		MHz
Full Power Response	20Vp-p, $R_L = 2\text{k}\Omega$		515			550			470		kHz
Slew Rate	$V_O = \pm 10\text{V}$, $R_L = 2\text{k}\Omega$	22	33		25	35		20	30		V/ μs
Settling Time ⁽¹⁾ : 0.1%	Gain = -1, $R_L = 2\text{k}\Omega$		1.0			1.0			1.0		μs
0.01%	10V Step		2.1			2.1			2.1		μs
Total Harmonic Distortion	G = +1, 20Vp-p $R_L = 2\text{k}\Omega$ f = 10kHz		0.0035			0.0035			0.0035		%
INPUT OFFSET VOLTAGE⁽²⁾											
Input Offset Voltage	$V_{CM} = 0\text{VDC}$		± 180	$\pm 1.5\text{mV}$		± 100	± 500		± 300	$\pm 3\text{mV}$	μV
Average Drift	$T_A = T_{MIN}$ to T_{MAX}		± 5			± 3	± 5		± 10		$\mu\text{V}/^\circ\text{C}$
Supply Rejection	$V_{CC} = \pm 10\text{V}$ to $\pm 18\text{V}$	82	100		90	104		80	90		dB
			± 10	± 79		± 6	± 32		± 32	± 100	$\mu\text{V/V}$
BIAS CURRENT⁽²⁾											
Input Bias Current	$V_{CM} = 0\text{VDC}$		± 7	± 15		± 5	± 10		± 8	± 25	pA
OFFSET CURRENT⁽²⁾											
Input Offset Current	$V_{CM} = 0\text{VDC}$		± 0.6	± 10		± 0.4	± 5		± 1	± 15	pA
NOISE											
Voltage, $f_O = 10\text{Hz}$	100% tested (L)		37			30	40		37		$\text{nV}/\sqrt{\text{Hz}}$
100Hz	100% tested (L)		21			20	28		21		$\text{nV}/\sqrt{\text{Hz}}$
1kHz	100% tested (L)		14			13	16		14		$\text{nV}/\sqrt{\text{Hz}}$
10kHz	⁽³⁾		12			11	13		12		$\text{nV}/\sqrt{\text{Hz}}$
20kHz	⁽³⁾		11			10.5	13		11		$\text{nV}/\sqrt{\text{Hz}}$
$f_B = 10\text{Hz}$ to 10kHz	⁽³⁾		1.3			1.2	1.5		1.3		μVrms
Current, $f_O = 0.1\text{Hz}$ thru 20kHz	⁽³⁾		1.5			1.3	2		1.7		$\text{fA}/\sqrt{\text{Hz}}$
IMPEDANCE											
Differential			$10^{13} \parallel 1$			$10^{13} \parallel 1$			$10^{13} \parallel 1$		$\Omega \parallel \text{pF}$
Common-Mode			$10^{14} \parallel 3$			$10^{14} \parallel 3$			$10^{14} \parallel 3$		$\Omega \parallel \text{pF}$
VOLTAGE RANGE											
Common-Mode Input Range		± 10.5	± 11.5		± 11	± 11.6		± 10.2	± 11		V
Common-Mode Rejection	$V_{IN} = \pm 10\text{VDC}$	80	95		85	96		78	90		dB
OPEN-LOOP GAIN, DC											
Open-Loop Voltage Gain	$R_L \geq 2\text{k}\Omega$	95	115		100	118		90	110		dB
RATED OUTPUT											
Voltage Output	$R_L = 2\text{k}\Omega$	± 11	± 12.2		± 12	± 12.6		± 11	± 12		V
Current Output	$V_O = \pm 10\text{VDC}$	± 5	± 10		± 5	± 10		± 5	± 10		mA
Output Resistance	DC, Open Loop		40			40			40		Ω
Load Capacitance Stability	Gain = +1		1000			1000			1000		pF
Short Circuit Current		10	20		10	20		10	20		mA
POWER SUPPLY											
Rated Voltage			± 15			± 15			± 15		VDC
Voltage Range, Derated Performance		± 5		± 18	± 5		± 18	± 5		± 18	VDC
Current, Quiescent	$I_O = 0\text{mADC}$		6.5	9.5		6.2	9		6.5	10	mA
TEMPERATURE RANGE											
Specification	Ambient Temperature										
	KM, KP, LM	0		+70	0		+70	0		+70	$^\circ\text{C}$
Operating	Ambient Temperature	-55		+125	-55		+125	-40		+85	$^\circ\text{C}$
θ_{JA}			200			200			155		$^\circ\text{C/W}$

NOTES: (1) See settling time test circuit in Figure 2. (2) Offset voltage, offset current, and bias current are measured with the units fully warmed up. (3) Sample tested—this parameter is guaranteed on L grade only.

ELECTRICAL (FULL TEMPERATURE RANGE SPECIFICATIONS)

At $V_{CC} = \pm 15\text{VDC}$ and $T_A = T_{MIN}$ to T_{MAX} unless otherwise noted.

PARAMETER	CONDITIONS	OPA606KM			OPA606LM			OPA606KP			UNITS
		MIN	TYP	MAX	MIN	TYP	MAX	MIN	TYP	MAX	
TEMPERATURE RANGE Specification Range	Ambient Temp.	0		+70	0		+70	0		+70	°C
INPUT OFFSET VOLTAGE⁽¹⁾ Input Offset Voltage Average Drift Supply Rejection	$V_{CM} = 0\text{VDC}$ $V_{CC} = \pm 10\text{V}$ to $\pm 18\text{V}$		± 400 ± 5 98 ± 13	$\pm 2\text{mV}$ ± 100		± 335 ± 3 100 ± 10	± 750 ± 5 ± 56		± 750 ± 10 95 ± 18	$\pm 3.5\text{mV}$ ± 126	μV $\mu\text{V}/^\circ\text{C}$ dB $\mu\text{V}/\text{V}$
BIAS CURRENT⁽¹⁾ Input Bias Current	$V_{CM} = 0\text{VDC}$		± 158	± 339		± 113	± 226		± 181	± 566	pA
OFFSET CURRENT⁽¹⁾ Input Offset Current	$V_{CM} = 0\text{VDC}$		± 14	± 226		± 9	± 113		± 23	± 339	pA
VOLTAGE RANGE Common-Mode Input Range Common-Mode Rejection	$V_{IN} = \pm 10\text{VDC}$	± 10.4 78	± 11.4 92		± 10.9 82	± 11.5 95		± 10 75	± 10.9 88		V dB
OPEN-LOOP GAIN, DC Open-Loop Voltage Gain	$R_L \geq 2\text{k}\Omega$	90	106		95	112		88	104		dB
RATED OUTPUT Voltage Output Current Output	$R_L = 2\text{k}\Omega$ $V_O = \pm 10\text{VDC}$	± 10.5 ± 5	± 12 ± 10		± 11.5 ± 5	± 12.4 ± 10		± 10.4 ± 5	± 11.8 ± 10		V mA
POWER SUPPLY Current, Quiescent	$I_O = 0\text{mA DC}$		6.6	10		6.4	9.5		6.6	10.5	mA

NOTES: (1) Offset voltage, offset current, and bias current are measured with the units fully warmed up.

ABSOLUTE MAXIMUM RATINGS

Supply Voltage	$\pm 18\text{VDC}$
Internal Power Dissipation ⁽¹⁾	500mW
Differential Input Voltage	$\pm 36\text{VDC}$
Input Voltage Range	$\pm 18\text{VDC}$
Storage Temperature Range	M = -65°C to $+150^\circ\text{C}$ P = -40°C to $+85^\circ\text{C}$
Operating Temperature Range	M = -55°C to $+125^\circ\text{C}$ P = -40°C to $+85^\circ\text{C}$
Lead Temperature (soldering, 10s)	$+300^\circ\text{C}$
Output Short-Circuit Duration ⁽³⁾	Continuous
Junction Temperature	$+175^\circ\text{C}$

NOTES: (1) Packages must be derated based on $\theta_{JC} = 15^\circ\text{C}/\text{W}$ or θ_{JA} . (2) For supply voltages less than $\pm 18\text{VDC}$, the absolute maximum input voltage is equal to the negative supply voltage. (3) Short circuit may be to power supply common only. Rating applies to $+25^\circ\text{C}$ ambient. Observe dissipation limit and T_J .

CONNECTION DIAGRAMS

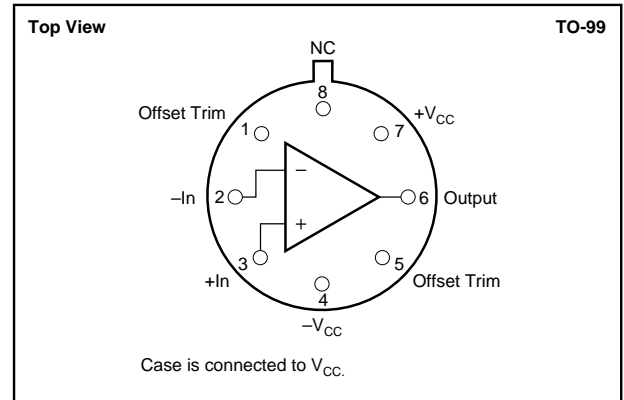

PACKAGE INFORMATION

MODEL	PACKAGE	PACKAGE DRAWING NUMBER ⁽¹⁾
OPA606KM	TO-99	001
OPA606LM	TO-99	001
OPA606KP	Plastic DIP	006

NOTE: (1) For detailed drawing and dimension table, please see end of data sheet, or Appendix D of Burr-Brown IC Data Book.

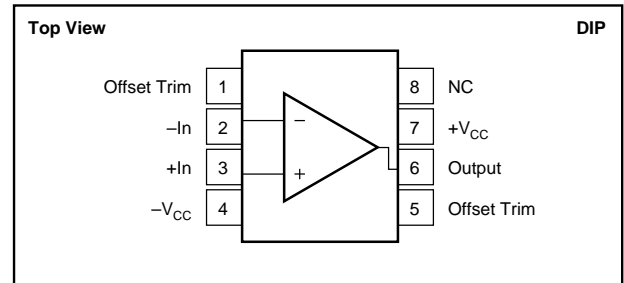

ORDERING INFORMATION

MODEL	PACKAGE	TEMPERATURE RANGE
OPA606KM	TO-99	0°C to 70°C
OPA606LM	TO-99	0°C to 70°C
OPA606KP	Plastic DIP	0°C to 70°C

DICE INFORMATION

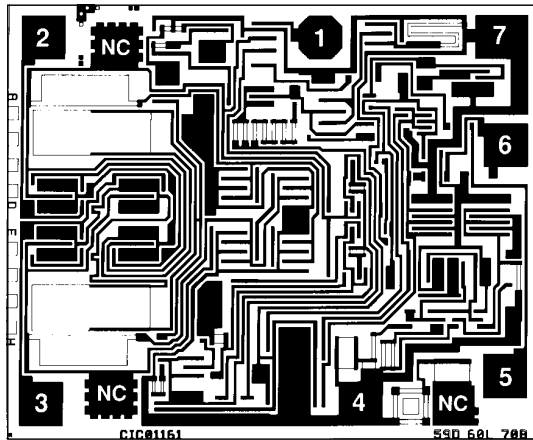

OPA606 DIE TOPOGRAPHY

PAD	FUNCTION
1	Offset Trim
2	-In
3	+In
4	-V _S
5	Offset Trim
6	Output
7	+V _S
8	NC
NC	No Connection

Substrate Bias: No Connection.

MECHANICAL INFORMATION

	MILS (0.001")	MILLIMETERS
Die Size	65 x 54 ±5	1.65 x 1.37 ±0.13
Die Thickness	20 ±3	0.51 ±0.08
Min. Pad Size	4 x 4	0.10 x 0.10
Backing		None
Transistor Count		43

The information provided herein is believed to be reliable; however, BURR-BROWN assumes no responsibility for inaccuracies or omissions. BURR-BROWN assumes no responsibility for the use of this information, and all use of such information shall be entirely at the user's own risk. Prices and specifications are subject to change without notice. No patent rights or licenses to any of the circuits described herein are implied or granted to any third party. BURR-BROWN does not authorize or warrant any BURR-BROWN product for use in life support devices and/or systems.

TYPICAL PERFORMANCE CURVES

$T_A = +25^\circ\text{C}$, $V_{CC} = \pm 15\text{VDC}$ unless otherwise noted.

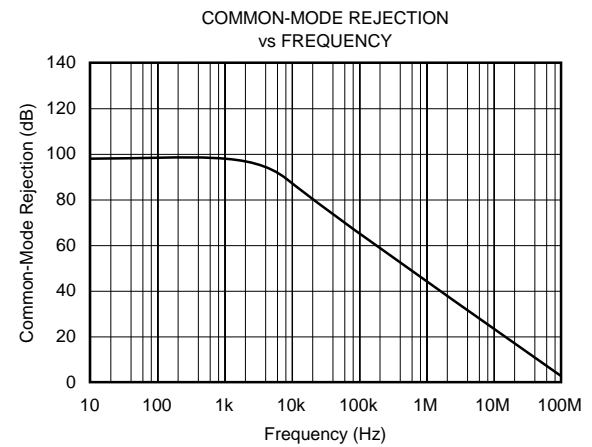
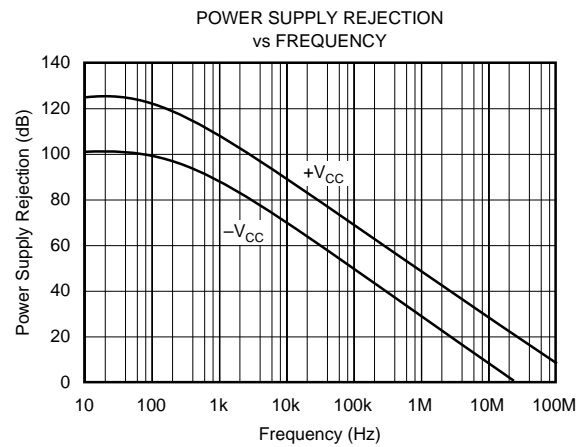
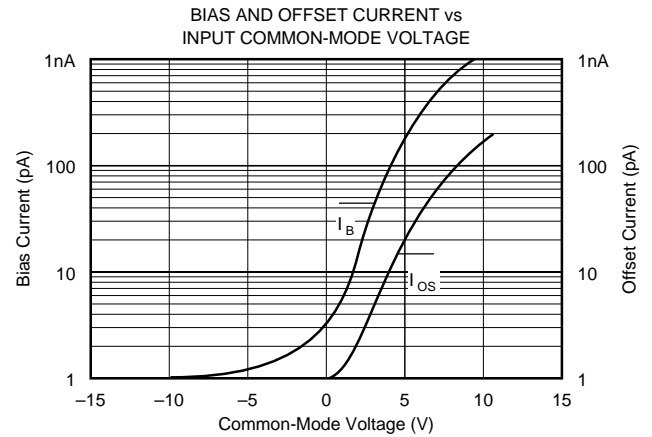
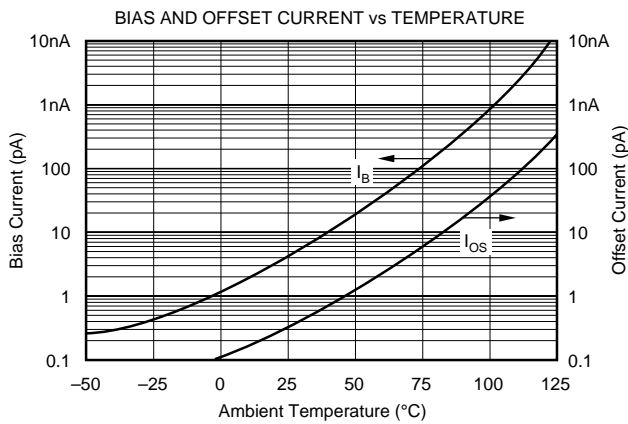
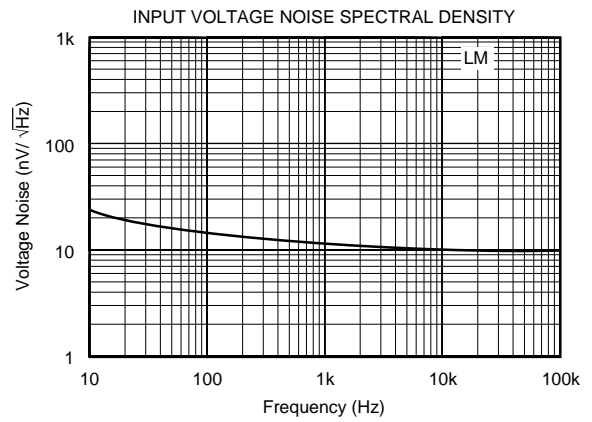
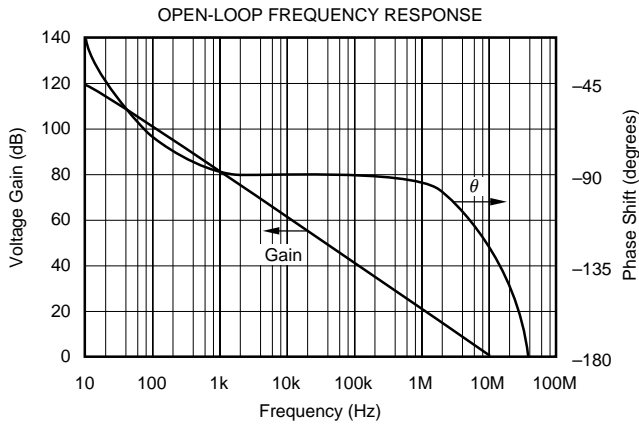

TYPICAL PERFORMANCE CURVES (CONT)

$T_A = +25^\circ\text{C}$, $V_{CC} = \pm 15\text{V}$ unless otherwise noted.

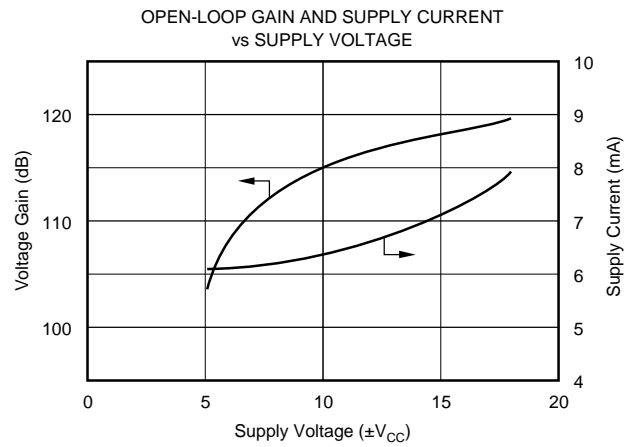
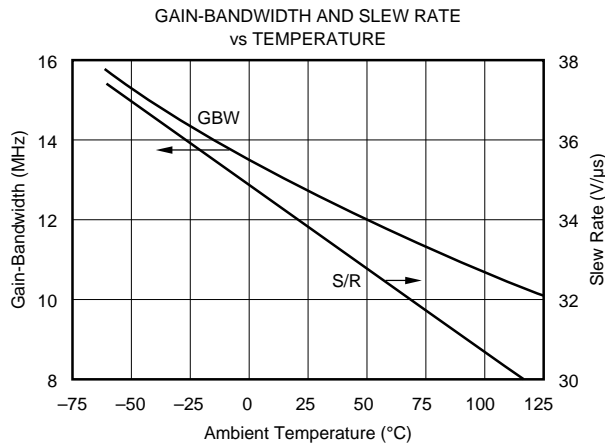
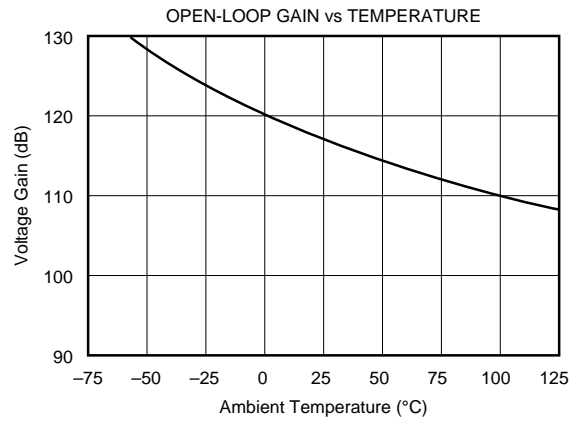
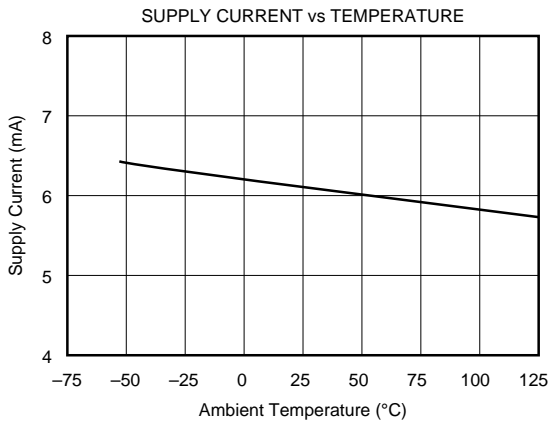
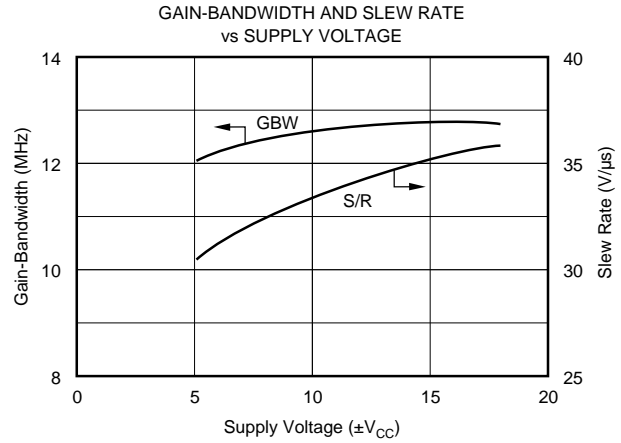
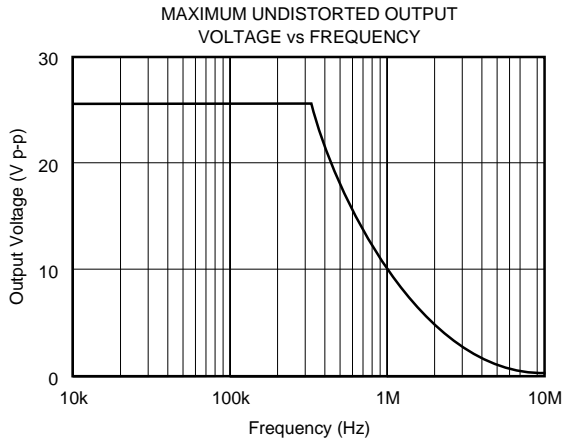

TYPICAL PERFORMANCE CURVES (CONT)

$T_A = +25^\circ\text{C}$, $V_{CC} = \pm 15\text{V}$ unless otherwise noted.

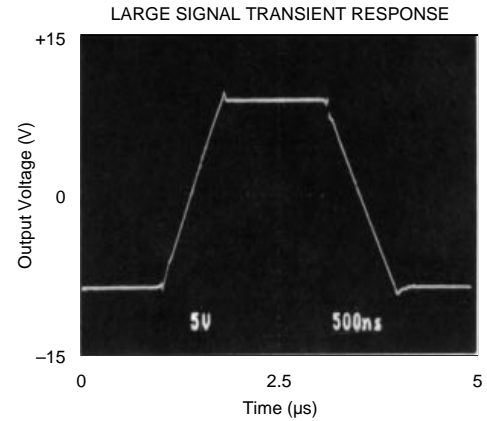
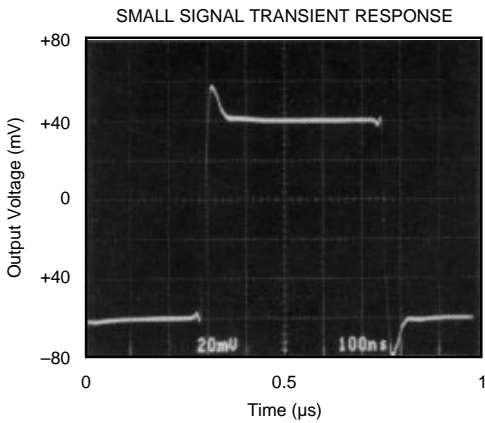
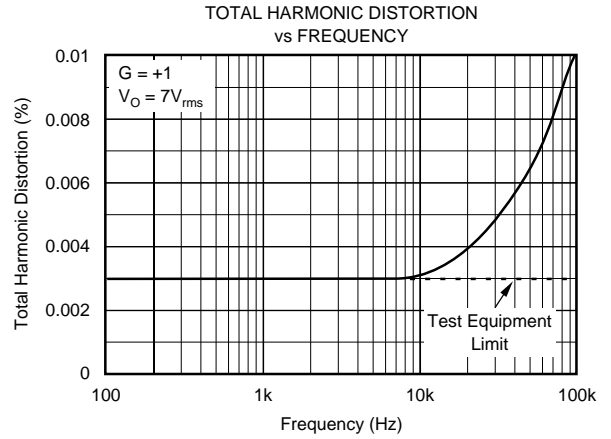
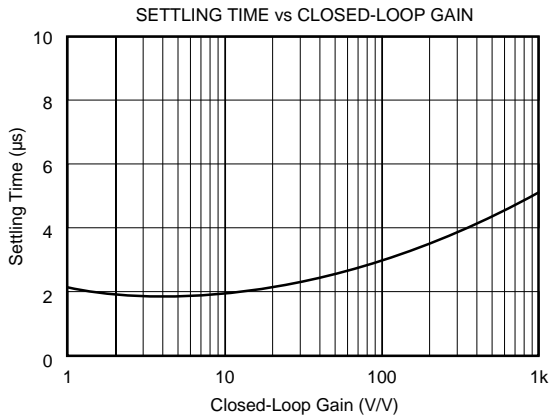

APPLICATIONS INFORMATION

OFFSET VOLTAGE ADJUSTMENT

The OPA606 offset voltage is laser-trimmed and will require no further trim for most applications. As with most amplifiers, externally trimming the remaining offset can change drift performance by about $0.5\mu\text{V}/^\circ\text{C}$ for each millivolt of adjusted offset. Note that the trim (Figure 1) is similar to operational amplifiers such as LF156 and OP-16. The OPA606 can replace most other amplifiers by leaving the external null circuit unconnected.

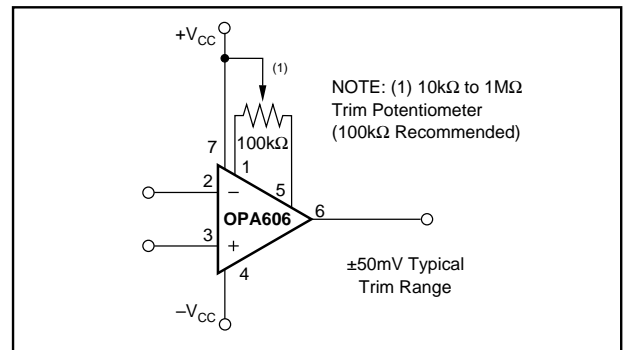

FIGURE 1. Offset Voltage Trim.

INPUT PROTECTION

Static damage can cause subtle changes in amplifier input characteristics without necessarily destroying the device. In precision operational amplifiers (both bipolar and FET types), this may cause a noticeable degradation of offset voltage and drift. Static protection is recommended when handling any precision IC operational amplifier.

If the input voltage exceeds the amplifier's negative supply voltage, input current limiting must be used to prevent damage.

CIRCUIT LAYOUT

Wideband amplifiers require good circuit layout techniques and adequate power supply bypassing. Short, direct connections and good high frequency bypass capacitors (ceramic or tantalum) will help avoid noise pickup or oscillation.

GUARDING AND SHIELDING

As in any situation where high impedances are involved, careful shielding is required to reduce "hum" pickup in input leads. If large feedback resistors are used, they should also be shielded along with the external input circuitry.

Leakage currents across printed circuit boards can easily exceed the bias current of the OPA606. To avoid leakage problems, it is recommended that the signal input lead of the OPA606 be wired to a Teflon® standoff. If the OPA606 is to be soldered directly into a printed circuit board, utmost care must be used in planning the board layout.

A "guard" pattern should completely surround the high impedance input leads and should be connected to a low impedance point which is at the signal input potential (see Figure 3).

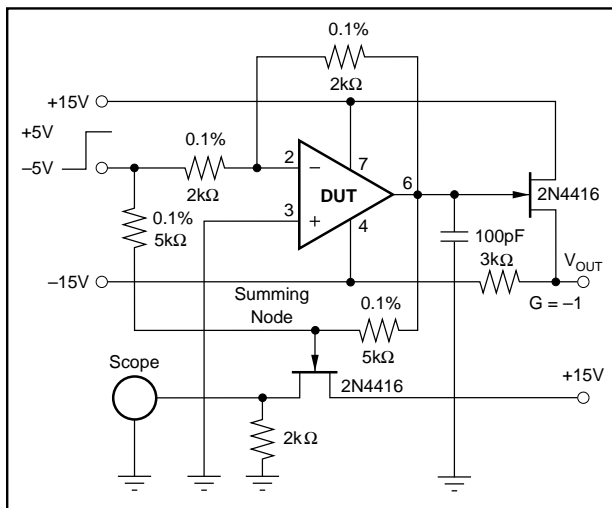

FIGURE 2. Settling Time Test Circuit.

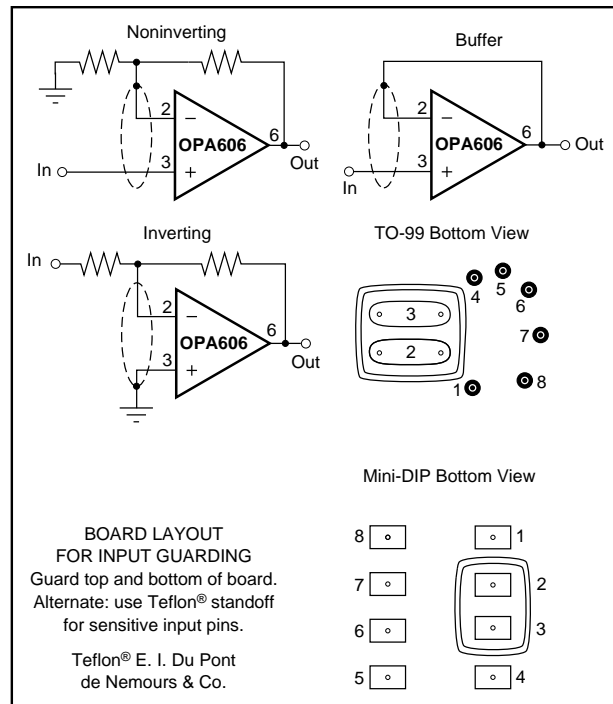

FIGURE 3. Connection of Input Guard.

APPLICATIONS CIRCUITS

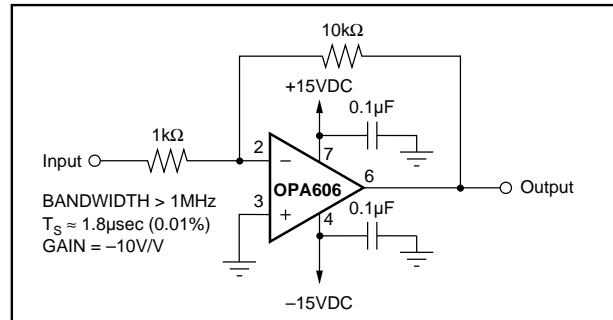

FIGURE 4. Inverting Amplifier.

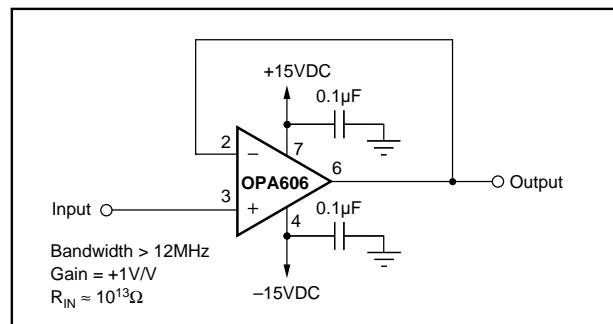

FIGURE 5. Noninverting Buffer.

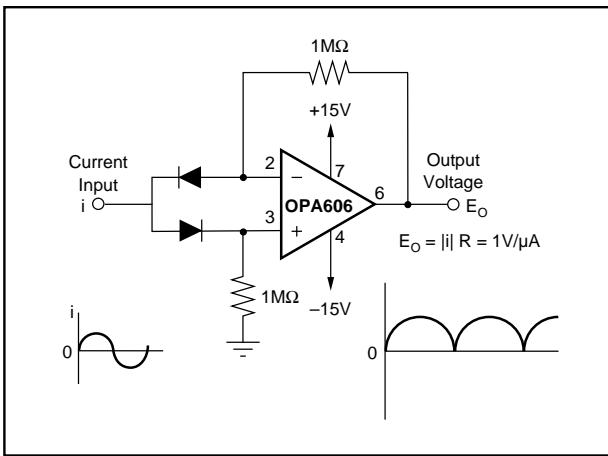

FIGURE 6. Absolute Value Current-to-Voltage Circuit.

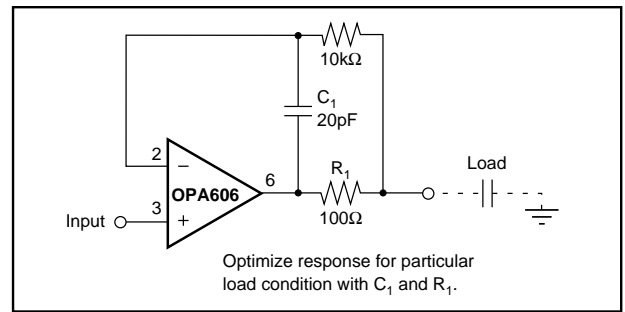

FIGURE 8. Isolating Load Capacitance from Buffer.

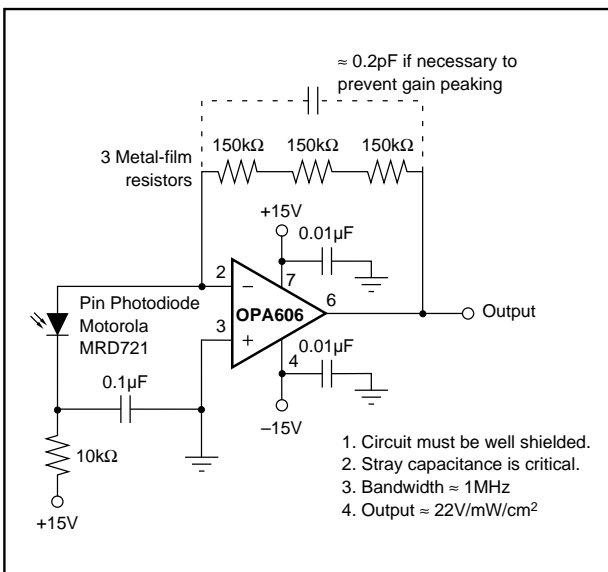

FIGURE 7. High-Speed Photodetector.

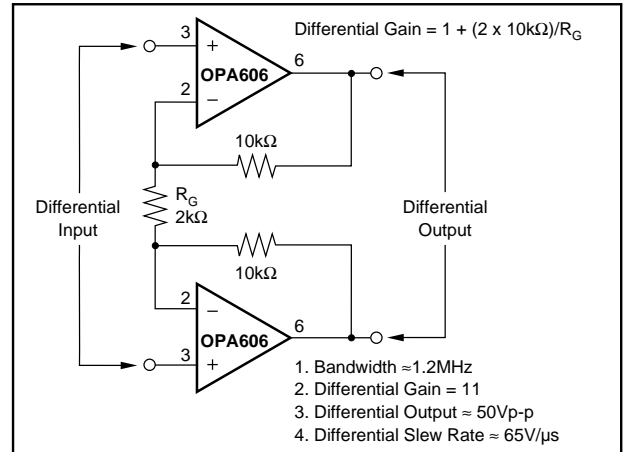

FIGURE 9. Differential Input/Differential Output Amplifier.

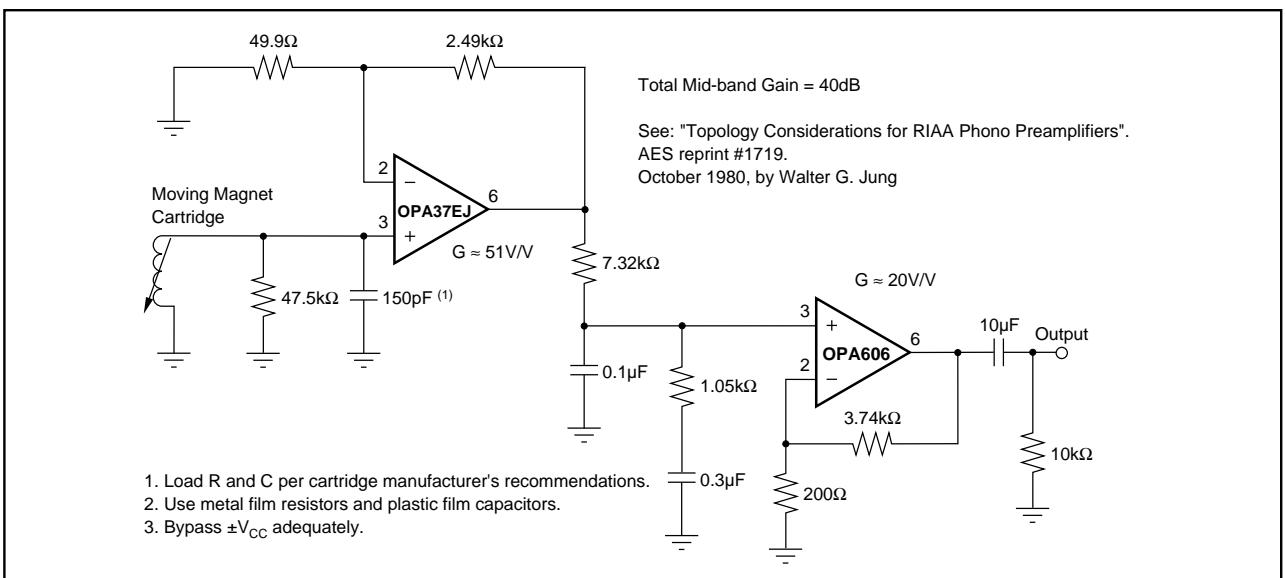

FIGURE 10. Low Noise/Low Distortion RIAA Preampfier.

PACKAGING INFORMATION

ORDERABLE DEVICE	STATUS(1)	PACKAGE TYPE	PACKAGE DRAWING	PINS	PACKAGE QTY
OPA606KM	OBSOLETE	TO/SOT	LMC	8	
OPA606KP	ACTIVE	PDIP	P	8	50
OPA606LM	OBSOLETE	TO/SOT	LMC	8	

(1) The marketing status values are defined as follows:

ACTIVE: Product device recommended for new designs.

LIFEBUY: TI has announced that the device will be discontinued, and a lifetime-buy period is in effect.

NRND: Not recommended for new designs. Device is in production to support existing customers, but TI does not recommend using this part in a new design.

PREVIEW: Device has been announced but is not in production. Samples may or may not be available.

OBSOLETE: TI has discontinued the production of the device.

IMPORTANT NOTICE

Texas Instruments Incorporated and its subsidiaries (TI) reserve the right to make corrections, modifications, enhancements, improvements, and other changes to its products and services at any time and to discontinue any product or service without notice. Customers should obtain the latest relevant information before placing orders and should verify that such information is current and complete. All products are sold subject to TI's terms and conditions of sale supplied at the time of order acknowledgment.

TI warrants performance of its hardware products to the specifications applicable at the time of sale in accordance with TI's standard warranty. Testing and other quality control techniques are used to the extent TI deems necessary to support this warranty. Except where mandated by government requirements, testing of all parameters of each product is not necessarily performed.

TI assumes no liability for applications assistance or customer product design. Customers are responsible for their products and applications using TI components. To minimize the risks associated with customer products and applications, customers should provide adequate design and operating safeguards.

TI does not warrant or represent that any license, either express or implied, is granted under any TI patent right, copyright, mask work right, or other TI intellectual property right relating to any combination, machine, or process in which TI products or services are used. Information published by TI regarding third-party products or services does not constitute a license from TI to use such products or services or a warranty or endorsement thereof. Use of such information may require a license from a third party under the patents or other intellectual property of the third party, or a license from TI under the patents or other intellectual property of TI.

Reproduction of information in TI data books or data sheets is permissible only if reproduction is without alteration and is accompanied by all associated warranties, conditions, limitations, and notices. Reproduction of this information with alteration is an unfair and deceptive business practice. TI is not responsible or liable for such altered documentation.

Resale of TI products or services with statements different from or beyond the parameters stated by TI for that product or service voids all express and any implied warranties for the associated TI product or service and is an unfair and deceptive business practice. TI is not responsible or liable for any such statements.

Following are URLs where you can obtain information on other Texas Instruments products and application solutions:

Products		Applications	
Amplifiers	amplifier.ti.com	Audio	www.ti.com/audio
Data Converters	dataconverter.ti.com	Automotive	www.ti.com/automotive
DSP	dsp.ti.com	Broadband	www.ti.com/broadband
Interface	interface.ti.com	Digital Control	www.ti.com/digitalcontrol
Logic	logic.ti.com	Military	www.ti.com/military
Power Mgmt	power.ti.com	Optical Networking	www.ti.com/opticalnetwork
Microcontrollers	microcontroller.ti.com	Security	www.ti.com/security
		Telephony	www.ti.com/telephony
		Video & Imaging	www.ti.com/video
		Wireless	www.ti.com/wireless

Mailing Address: Texas Instruments
Post Office Box 655303 Dallas, Texas 75265

Copyright © 2003, Texas Instruments Incorporated

Looking for pricing, stock, or lifecycle information?

Click below to explore more details on WIN SOURCE:

 [View OPA606KM](#) on WIN SOURCE

 [Texas Instruments](#) Information

Optimize Your Supply Chain with WIN SOURCE Solutions

-  Global Sourcing Solution
-  Obsolete Management
-  Cost Control Management
-  Shortage Management
-  Alternative Solution
-  Excess Inventory Management