



**THE DATASHEET OF  
TAS3004PFBG4**



# **TAS3004**

## ***Digital Audio Processor With Codec***

*Data  
Manual*

# Contents

<i>Section</i>	<i>Title</i>	<i>Page</i>
<b>1</b>	<b>Introduction</b>	<b>1-1</b>
1.1	Description	1-1
1.2	Features	1-1
1.3	Functional Block Diagram	1-3
1.4	Terminal Assignments	1-4
1.5	Terminal Functions	1-4
<b>2</b>	<b>Audio Data Formats</b>	<b>2-1</b>
2.1	Serial Interface Formats	2-1
2.2	ADC Digital Output Modes	2-2
2.2.1	MSB First, Right-Justified Serial Interface Format—Normal Mode	2-2
2.2.2	I <sup>2</sup> S Serial Interface Format—Normal Mode	2-3
2.2.3	MSB Left-Justified Serial Interface Format—Normal Mode	2-4
2.3	ADC Digital Output Mode—Monaural	2-4
2.3.1	MSB First, Right-Justified Serial Interface Format—Monaural ADC Mode, B Left Input Selected	2-5
2.3.2	I <sup>2</sup> S Serial Interface Format—Monaural ADC Mode, B Left Input Selected	2-6
2.3.3	MSB Left-Justified Serial Interface Format—Monaural ADC Mode, B Left Input Selected	2-7
2.3.4	MSB First, Right-Justified Serial Interface Format—Monaural ADC Mode, B Right Input Selected	2-8
2.3.5	I <sup>2</sup> S Serial Interface Format—Monaural ADC Mode, B Right Input Selected	2-9
2.3.6	MSB Left-Justified Serial Interface Format—Monaural ADC Mode, B Right Input Selected	2-10
2.4	Switching Characteristics	2-11
<b>3</b>	<b>Analog Input/Output</b>	<b>3-1</b>
3.1	Analog Input	3-1
3.2	Analog Output	3-1
3.2.1	Analog Output	3-1
3.2.2	Analog Output With Gain	3-2
3.2.3	Reference Voltage Filter	3-3
<b>4</b>	<b>Audio Control/Enhancement Functions</b>	<b>4-1</b>
4.1	Soft Volume Update	4-1
4.2	Software Soft Mute	4-1
4.3	Input Mixer Control	4-1
4.4	Mono Mixer Control	4-2
4.5	Treble Control	4-2

4.6	Bass Control .....	4-3
4.7	De-Emphasis (DM) .....	4-3
4.8	Analog Control Register Operation .....	4-4
4.9	Dynamic Loudness Contour .....	4-5
4.9.1	Loudness Biquads .....	4-5
4.9.2	Loudness Gain .....	4-5
4.9.3	Loudness Contour Operation .....	4-5
4.10	Dynamic Range Compression/Expansion .....	4-6
4.11	AllPass Function .....	4-6
4.12	Main Control Register 2 (43h) .....	4-7
<b>5</b>	<b>Filter Processor .....</b>	<b>5-1</b>
5.1	Biquad Block .....	5-1
5.1.1	Filter Coefficients .....	5-1
5.1.2	Biquad Structure .....	5-1
<b>6</b>	<b>I<sup>2</sup>C Serial Control Interface .....</b>	<b>6-1</b>
6.1	Introduction .....	6-1
6.2	I <sup>2</sup> C Protocol .....	6-1
6.3	Operation .....	6-2
6.3.1	Write Cycle Example .....	6-2
6.3.2	TAS3004 I <sup>2</sup> C Readback Example .....	6-3
6.3.3	I <sup>2</sup> C Wait States .....	6-3
6.4	SMBus Operation .....	6-4
6.4.1	Block Write Protocol .....	6-4
6.4.2	Write Byte Protocol .....	6-4
6.4.3	Wait States .....	6-5
6.4.4	TAS3004 SMBus Readback .....	6-5
<b>7</b>	<b>Microcontroller Operation .....</b>	<b>7-1</b>
7.1	General Description .....	7-1
7.2	Power-Up/Power-Down Reset .....	7-1
7.2.1	Power-Up Sequence .....	7-1
7.2.2	Reset .....	7-1
7.2.3	Reset Circuit .....	7-2
7.2.4	Fast Load Mode .....	7-2
7.2.5	Codec Reset .....	7-3
7.3	Power-Down Mode .....	7-3
7.3.1	Power-Down Timing Sequence .....	7-3
7.4	Test Mode .....	7-4
7.5	Internal Interface .....	7-4
7.6	GPI Terminal Programming .....	7-4
7.6.1	Switch Interface .....	7-4
7.6.2	GPI Architecture .....	7-4
7.7	External EPROM Memory Maps .....	7-6
<b>8</b>	<b>Electrical Characteristics .....</b>	<b>8-1</b>
8.1	Absolute Maximum Ratings Over Operating Temperature Ranges ..	8-1

8.2	Recommended Operating Conditions .....	8-1
8.3	Static Digital Specifications .....	8-1
8.4	ADC Digital Filter .....	8-2
8.5	Analog-to-Digital Converter .....	8-3
8.6	Input Multiplexer .....	8-4
8.7	DAC Interpolation Filter .....	8-4
8.8	Digital-to-Analog Converter .....	8-5
8.9	DAC Output Performance Data .....	8-5
8.10	I <sup>2</sup> C Serial Port Timing Characteristics .....	8-6
<b>9</b>	<b>System Diagrams .....</b>	<b>9-1</b>
<b>10</b>	<b>Mechanical Information .....</b>	<b>10-1</b>
<b>A</b>	<b>Software Interface .....</b>	<b>A-1</b>
A.1	Main Control Register Map .....	A-3
A.1.1	Main Control Register 1 .....	A-3
A.1.2	Main Control Register 2 .....	A-3
A.1.3	Analog Control Register 2 .....	A-4
A.2	Volume Gain Command .....	A-5
A.3	Treble Control Register Command .....	A-6
A.4	Bass Control Register Command .....	A-7
A.5	I <sup>2</sup> C Mix Register Command .....	A-7
A.6	Programming Instruction for the Loudness Contour .....	A-9
A.7	Examples of DRCE .....	A-9
A.7.1	DRCE On/Off .....	A-9
A.7.2	Above Threshold Ratios .....	A-10
A.7.3	Below Threshold Ratios .....	A-11
A.7.4	Threshold .....	A-12
A.7.5	Time Constants .....	A-12
A.7.6	DRCE Example With Threshold at -12 dB .....	A-13

## List of Illustrations

<i>Figure</i>	<i>Title</i>	<i>Page</i>
1-1	TAS3004 Block Diagram .....	1-3
1-2	TAS3004 Terminal Assignments .....	1-4
2-1	MSB First, Right-Justified Serial Interface Format—Normal Mode .....	2-2
2-2	I <sup>2</sup> S Serial Interface Format—Normal Mode .....	2-3
2-3	MSB Left-Justified Serial Interface Format—Normal Mode .....	2-4
2-4	MSB First, Right-Justified Serial Interface Format—Monaural ADC Mode, B Left Input Selected .....	2-5
2-5	I <sup>2</sup> S Serial Interface Format—Monaural ADC Mode, B Left Input Selected .....	2-6
2-6	MSB Left-Justified Serial Interface Format—Monaural ADC Mode, B Left Input Selected .....	2-7
2-7	MSB First, Right-Justified Serial Interface Format—Monaural ADC Mode, B Right Input Selected .....	2-8
2-8	I <sup>2</sup> S Serial Interface Format—Monaural ADC Mode, B Right Input Selected .....	2-9
2-9	MSB Left-Justified Serial Interface Format—Monaural ADC Mode, B Right Input Selected .....	2-10
2-10	For Right-/Left-Justified, I <sup>2</sup> S, and Left-/Left-Justified Serial Protocols ..	2-11
3-1	Analog Input to the TAS3004 Device .....	3-1
3-2	VCOM Decoupling Network .....	3-2
3-3	Analog Output With External Amplifier .....	3-2
3-4	TAS3004 Reference Voltage Filter .....	3-3
4-1	TAS3004 Mix Function .....	4-2
4-2	De-Emphasis Mode Frequency Response .....	4-3
4-3	Block Diagram .....	4-5
4-4	TAS3004 Digital Signal Processing Block Diagram .....	4-6
5-1	Biquad Cascade Configuration .....	5-1
6-1	Typical I <sup>2</sup> C Data Transfer Sequence .....	6-1
7-1	TAS3004 Reset Circuit .....	7-2
7-2	Power-Down Timing Sequence .....	7-3
7-3	Internal Interface Block Diagram .....	7-5
8-1	ADC Digital Filter Characteristics .....	8-2
8-2	ADC Digital Filter Stopband Characteristics .....	8-2
8-3	ADC Digital Filter Passband Characteristics .....	8-3
8-4	ADC High Pass Filter Characteristics .....	8-3
8-5	DAC Filter Overall Frequency Characteristics .....	8-4

8-6	DAC Digital Filter Passband Ripple Characteristics .....	8-4
8-7	I <sup>2</sup> C Bus Timing .....	8-6
9-1	Stereo Application .....	9-1
9-2	TAS3004 Device, 2.1 Channels .....	9-2
A-1	TAS3004 DRCE Characteristics in the dB Domain .....	A-10
A-2	DRCE Example With Threshold at -12 dB .....	A-13

## List of Tables

<i>Table</i>	<i>Title</i>	<i>Page</i>
1–1	TAS3004 Terminal Functions .....	1–4
2–1	Serial Interface Options .....	2–1
4–1	Analog Control Register Description .....	4–4
4–2	Main Control Register 2 Description .....	4–7
6–1	I <sup>2</sup> C Protocol Definitions .....	6–2
6–2	I <sup>2</sup> C Address Byte Table .....	6–2
6–3	I <sup>2</sup> C Wait States .....	6–4
7–1	GPI Terminal Programming .....	7–4
7–2	512-Byte EEPROM Memory Map 2.0 Channels .....	7–6
7–3	512-Byte EEPROM Memory Map 2.1 Channels (with TAS3001) .....	7–7
7–4	2048-Byte EEPROM Memory Map—2.0 Speakers With Multiple Equalizations .....	7–8
7–5	2048-Byte EEPROM Memory Map—2.1 Speakers With Multiple Equalizations .....	7–9
A–1	I <sup>2</sup> C Register Map .....	A–1
A–2	Main Control Register 1 Description .....	A–3
A–3	Main Control Register 2 Description .....	A–4
A–4	Analog Control Register 2 Description .....	A–4
A–5	Volume Versus Gain Values .....	A–5
A–6	Treble Control Register .....	A–6
A–7	Bass Control Register .....	A–7
A–8	Mixer1 and Mixer2 Gain Values .....	A–8
A–9	Example of a DRCE I <sup>2</sup> C Instruction With DRCE On .....	A–9
A–10	Example of a DRCE I <sup>2</sup> C Instruction With DRCE Off .....	A–9
A–11	Above Threshold Ratios for Compression .....	A–10
A–12	Above Threshold Ratios for Expansion .....	A–11
A–13	Below Threshold Ratios for Expansion .....	A–11
A–14	Below Threshold Ratios for Compression .....	A–11
A–15	Threshold Values .....	A–12
A–16	Time Constants .....	A–13

# 1 Introduction

## 1.1 Description

The TAS3004 device is a system-on-a-chip that replaces conventional analog equalization to perform digital parametric equalization, dynamic range compression, and loudness contour. Additionally, this device provides high-quality, soft digital volume, bass, and treble control. All control parameters are uploaded through the I<sup>2</sup>C port from an outside MCU through the I<sup>2</sup>C slave port or from an external EPROM through the I<sup>2</sup>C master port.

The TAS3004 device also has an integrated 24-bit stereo codec with two I<sup>2</sup>C-selectable, single-ended inputs per channel.

The digital parametric equalization consists of seven cascaded, independent biquad filters per channel. Each biquad filter has five 24-bit coefficients that can be configured into many different filter functions (such as bandpass, high pass, and low pass).

The internal loudness contour algorithm can be controlled and programmed with an I<sup>2</sup>C command.

Dynamic range compression/expansion (DRCE) is programmable through the I<sup>2</sup>C port. The system designer can set the threshold, energy estimation time constant, compression ratio, and attack and decay time constants.

The TAS3004 device supports 13 serial interface formats (I<sup>2</sup>S, left justified, right justified) with data word lengths of 16, 18, 20, or 24 bits. The sampling frequency ( $f_S$ ) may be set to 32 kHz, 44.1 kHz, or 48 kHz.

The TAS3004 device uses a system clock generated by the internal phase-locked loop (PLL). The reference clock for the PLL is provided by an external master clock (MCLK) of  $256f_S$  or  $512f_S$ , or a  $256f_S$  crystal.

The TAS3004 device has six internally configurable general-purpose input (GPI) terminals that control volume, bass, treble, and equalization. Each GPI terminal has a debounce algorithm that is programmed into the TAS3004 internal microcontroller.

## 1.2 Features

- Programmable seven-band parametric equalization
- Programmable digital volume control
- Programmable digital bass and treble control
- Programmable dynamic range compression/expansion (DRCE)
- Programmable loudness contour/dynamic bass control
- Configurable serial port for audio data
- Two input data channels that can be mixed with digital data from the analog-to-digital converter (ADC) of the codec (analog input). These channels are controlled by I<sup>2</sup>C commands.
- Three output data channels: Left and right data go through equalization; bass, treble, DRCE, and volume to SDOUT1; SDOUT2 mixes left and right data. SDOUT2 operates as a center channel or subwoofer channel. The output of the ADC is available for additional processing.
- Capability to configure ADC output to one of two monaural data streams or one stereo data stream
- Capability to digitally mix left and right input channels for a monaural output to facilitate subwoofer operation
- Serial I<sup>2</sup>C master/slave port that allows:
  - Downloading of control data to the device externally from the EPROM or an I<sup>2</sup>C master

- Controlling other I<sup>2</sup>C devices
- Two I<sup>2</sup>C-selectable, single-ended analog input stereo channels
- Equalization bypass mode
- Single 3.3-V power supply
- Powerdown without reloading the coefficients
- Sampling rates: 32 kHz, 44.1 kHz, or 48 kHz
- Master clock frequency,  $256f_S$  or  $512f_S$
- Can have crystal input to replace MCLK. Crystal input frequency is  $256f_S$ .
- Six GPI terminals for volume, bass, treble up/down control, mute, and selection of equalization filters

### 1.3 Functional Block Diagram

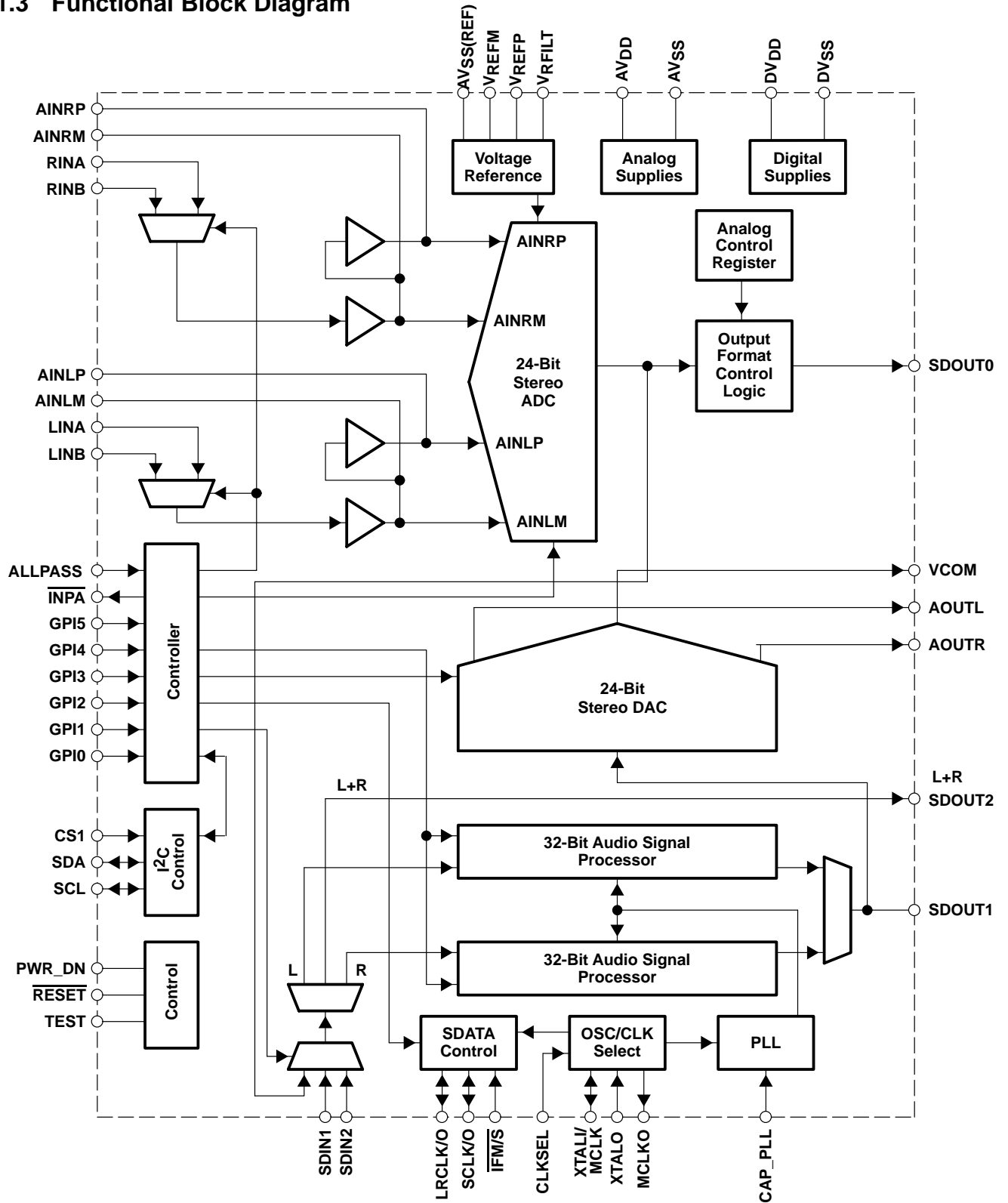

Figure 1–1. TAS3004 Block Diagram

## 1.4 Terminal Assignments

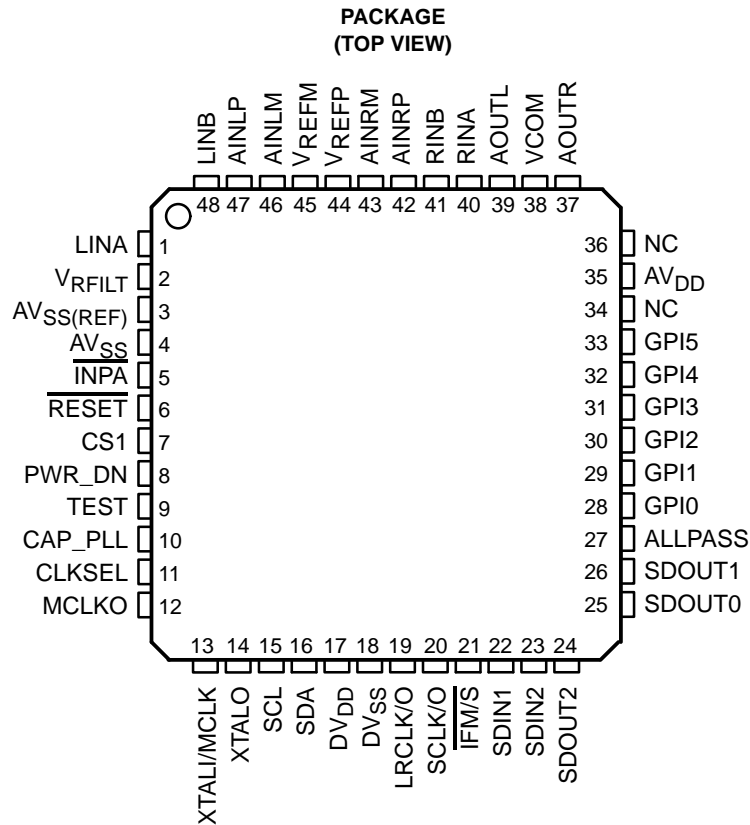

Figure 1–2. TAS3004 Terminal Assignments

## 1.5 Terminal Functions

Table 1–1. TAS3004 Terminal Functions

TERMINAL NAME	NO.	I/O	DESCRIPTION
AINLM	46	I	ADC left channel analog input (anti-alias capacitor)
AINLP	47	I	ADC left channel analog input (anti-alias capacitor)
AINRM	43	I	ADC right channel analog input (anti-alias capacitor)
AINRP	42	I	ADC right channel analog input (anti-alias capacitor)
ALLPASS	27	I	Logic high bypasses equalization filters
AOATL	39	O	Left channel analog output
AOATR	37	O	Right channel analog output
AVDD	35	I	Analog power supply (3.3 V)
AVSS	4	I	Analog voltage ground
AVSS(REF)	3	I	Analog ground voltage reference
CAP_PLL	10	I	Loop filter for internal phase-locked loop (PLL)
CLKSEL	11	I	Logic low selects 256f <sub>S</sub> ; logic high selects 512f <sub>S</sub> MCLK
CS1	7	I	I <sup>2</sup> C address bit A0; low = 68h, high = 6Ah

**Table 1–1. TAS3004 Terminal Functions (Continued)**

TERMINAL NAME	NO.	I/O	DESCRIPTION
DVDD	17	I	Digital power supply (3.3 V)
DVSS	18	I	Digital ground
GPI0	28	I	Switch input terminals
GPI1	29		
GPI2	30		
GPI3	31		
GPI4	32		
GPI5	33		
$\overline{\text{IFM/S}}$	21	I	Digital audio I/O control (low = input; high = output)
$\overline{\text{INPA}}$	5	O	Low when analog input A is selected (will sink 4 mA)
LINA	1	I	Left channel analog input 1
LINB	48	I	Left channel analog input 2
LRCLK/O	19	I/O	Left/right clock input/output (output when $\overline{\text{IFM/S}}$ is high)
MCLKO	12	O	MCLK output for slave devices
NC	34		No connection; Can be used as a printed circuit board routing channel
NC	36		No connection; Can be used as a printed circuit board routing channel
PWR_DN	8	I	Logic high places the TAS3004 device in power-down mode
$\overline{\text{RESET}}$	6	I	Logic low resets the TAS3004 device to the initial state
RINA	40	I	Right channel analog input 1
RINB	41	I	Right channel analog input 2
SCL	15	I/O	I <sup>2</sup> C clock connection
SCLK/O	20	I/O	Shift (bit) clock input (output when $\overline{\text{IFM/S}}$ is high)
SDA	16	I/O	I <sup>2</sup> C data connection
SDIN1	22	I	Serial data input 1
SDIN2	23	I	Serial data input 2
SDOUT1	26	O	Serial data output (from internal audio processing)
SDOUT2	24	O	Serial data output (a monaural mix of left and right, before processing)
SDOUT0	25	O	Serial data output from ADC
TEST	9	I	Reserved manufacturing test terminal; connect to DVSS
VCOM	38	O	Digital-to-analog converter mid-rail supply (decouple with parallel combination of 10- $\mu$ F and 0.1- $\mu$ F capacitors)
VREFM	45	I	ADC minus voltage reference
VREFP	44	I	ADC plus voltage reference
VRFILT	2	O	Voltage reference low pass filter
XTALI/MCLK	13	I	Crystal or external MCLK input
XTALO	14	I	Crystal input (crystal is connected between terminals 13 and 14)



## 2 Audio Data Formats

### 2.1 Serial Interface Formats

The TAS3004 device works in master or slave mode.

In the master mode, terminal 21 ( $\overline{\text{IFM/S}}$ ) is tied high. This activates the master clock (MCLK) circuitry. A crystal can be connected across terminals 13 (XTALI/MCLK) and 14 (XTALO), or an external, TTL-compatible MCLK can be connected to XTALI/MCLK. In that case, MCLK outputs from terminal 12 (MCLKO) with terminals 19 (LRCLK/O) and 20 (SCLK/O) becoming outputs to drive slave devices.

In the slave mode,  $\overline{\text{IFM/S}}$  is tied low. LRCLK/O and SCLK/O are inputs and the interface operates as a slave device requiring externally supplied MCLK, LRCLK (left/right clock), and SCLK (shift clock) inputs. There are two options for selecting the clock rates. If the  $512f_S$  MCLK rate is selected, terminal 11 (CLKSEL) is tied high and an MCLK rate of  $512f_S$  must be supplied. If the  $256f_S$  MCLK is selected, CLKSEL is tied low and an MCLK of  $256f_S$  must be supplied. In both cases, an LRCLK of  $64\text{SCLK}$  must be supplied.

- MCLK and SCLK must be synchronous and their edges must be at least 3 ns apart.
- If the LRCLK phase changes more than  $10\text{MCLK}$ , the codec automatically resets.

The TAS3004 device is compatible with 13 different serial interfaces. Available interface options are I<sup>2</sup>S, right justified, and left justified. Table 2–1 indicates how the 13 options are selected using the I<sup>2</sup>C bus and the main control register (MCR, I<sup>2</sup>C address x01h). All serial interface options at either 16, 18, 20, or 24 bits operate with SCLK at  $64f_S$ . Additionally, the 16-bit mode operates at  $32f_S$ .

**Table 2–1. Serial Interface Options**

MODE	MCR BIT (6)	MCR BIT (5–4)	MCR BIT (1–0)	SERIAL INTERFACE SDIN1, SDIN2, SDOUT1, SDOUT2, AND SDOUT0
0	0	00	00	16-bit, left justified, $32f_S$
1	1	00	00	16-bit, left justified, $64f_S$
2	1	01	00	16-bit, right justified, $64f_S$
3	1	10	00	16-bit, I <sup>2</sup> S, $64f_S$
4	1	00	01	18-bit, left justified, $64f_S$
5	1	01	01	18-bit, right justified, $64f_S$
6	1	10	01	18-bit, I <sup>2</sup> S, $64f_S$
7	1	00	10	20-bit, left justified, $64f_S$
8	1	01	10	20-bit, right justified, $64f_S$
9	1	10	10	20-bit, I <sup>2</sup> S, $64f_S$
10	1	00	11	24-bit, left justified, $64f_S$
11	1	01	11	24-bit, right justified, $64f_S$
12	1	10	11	24-bit, I <sup>2</sup> S, $64f_S$

Figure 2–1 through Figure 2–9 illustrate the relationship between the SCLK, LRCLK, and the serial data I/O for the different interface protocols.

## 2.2 ADC Digital Output Modes

ADC digital output mode (SDOUT0) has two operational modes, normal and monaural. In the normal mode, the output of the ADC conforms to the output modes described in Sections 2.2.1 through 2.2.3. To enter the normal output mode, bit 7 (ADM) in the analog control register must be cleared to 0. In the monaural output mode, the digital output of the ADC conforms to the output modes described in Sections 2.3.1 through 2.3.6. To enter the monaural mode, bit 7 (ADM) in the analog control register must be set to 1.

### 2.2.1 MSB First, Right-Justified Serial Interface Format—Normal Mode

The normal output mode for the MSB first, right-justified serial interface format is for 16, 18, 20, and 24 bits with bit 7 (ADM) in the analog control register cleared to 0. Figure 2–1 shows the following characteristics of this protocol:

- Left channel is transmitted when LRCLK is high.
- The SDIN(s) (recorded) data is justified to the trailing edge of the LRCLK.
- The SDOUT(s) MSB (playback) data is transmitted at the same time as LRCLK edge and captured at the next rising edge of SCLK.
- If LRCLK phase changes by more than 10MCLK, the codec automatically resets.

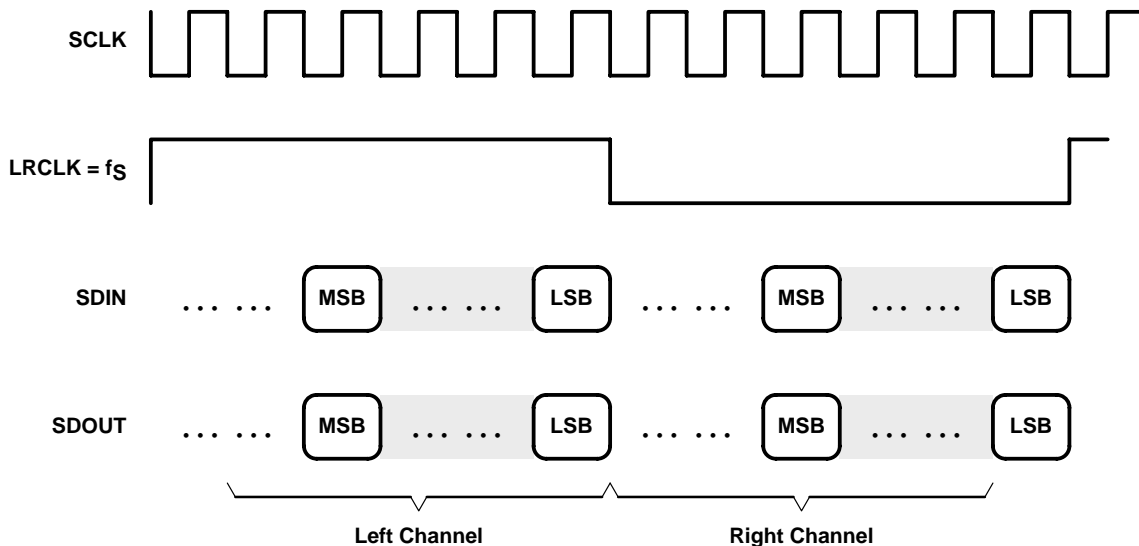

Figure 2–1. MSB First, Right-Justified Serial Interface Format—Normal Mode

## 2.2.2 I<sup>2</sup>S Serial Interface Format—Normal Mode

The normal output mode for the I<sup>2</sup>S serial interface format is for 16, 18, 20, and 24 bits with bit 7 (ADM) in the analog control register cleared to 0.

Figure 2–2 shows the following characteristics of this protocol:

- Left channel is transmitted when LRCLK is low.
- SDIN is sampled with the rising edge of SCLK.
- SDOUT is transmitted on the falling edge of SCLK.
- If LRCLK phase changes by more than 10MCLK, the codec automatically resets.

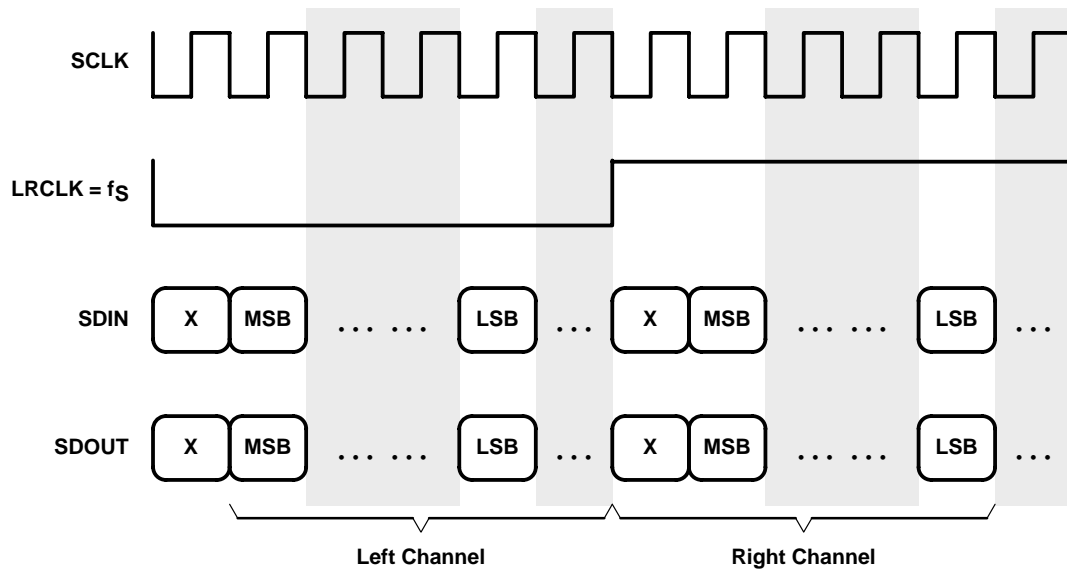

Figure 2–2. I<sup>2</sup>S Serial Interface Format—Normal Mode

### 2.2.3 MSB Left-Justified Serial Interface Format—Normal Mode

The normal output mode for the MSB left-justified serial interface format is for 16, 18, 20, and 24 bits with bit 7 (ADM) in the analog control register cleared to 0.

Figure 2–3 shows the following characteristics of this protocol:

- Left channel is transmitted when LRCLK is high.
- The SDIN data is justified to the leading edge of the LRCLK.
- The MSBs are transmitted at the same time as LRCLK edge and captured at the next rising edge of SCLK.

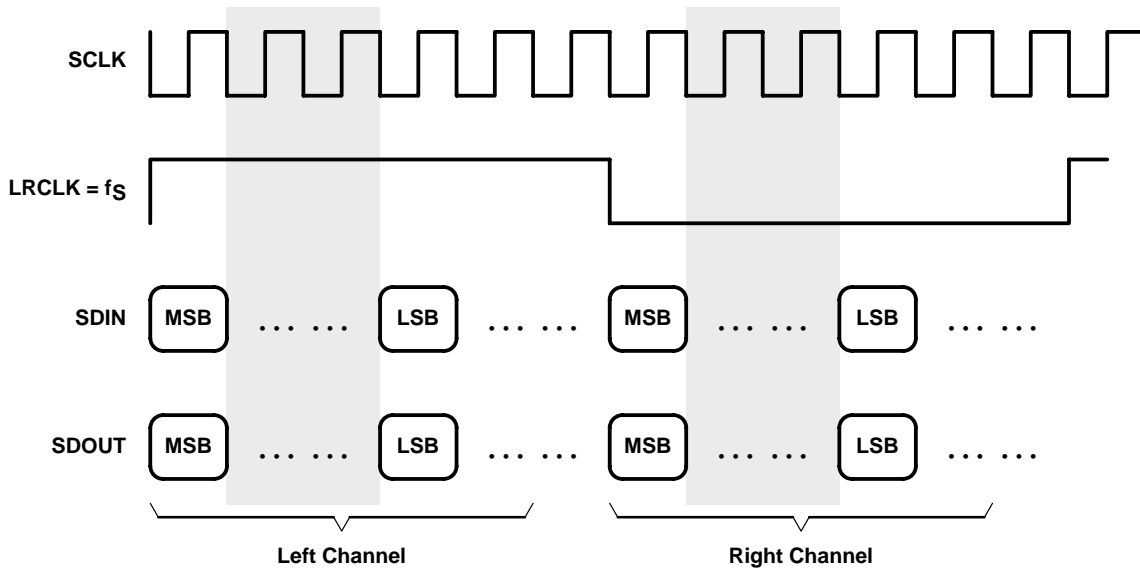

Figure 2–3. MSB Left-Justified Serial Interface Format—Normal Mode

### 2.3 ADC Digital Output Mode—Monaural

For the monaural ADC digital output mode, bit 7 (ADM) is set to 1, and bit 6 (LRB) and bit 1 (INP) in the analog control register (see Section 4.8, *Analog Control Register Operation*) control the operation of the monaural output mode. All interface formats are for 16, 18, 20, and 24 bits.

### 2.3.1 MSB First, Right-Justified Serial Interface Format—Monaural ADC Mode, B Left Input Selected

The monaural output mode for the MSB first, right-justified serial interface format is for 16, 18, 20, and 24 bits with the following bits in the analog control register set as shown:

- Bit 7 (ADM) is set to 1.
- Bit 6 (LRB) is cleared to 0.
- Bit 1 (INP) is set to 1.

Figure 2–4 shows the following characteristics of this protocol:

- Left channel is transmitted when LRCLK is either high or low.
- The SDIN(s) (recorded) data is justified to the trailing edge of the LRCLK.
- The SDOUT(s) MSB (playback) data is transmitted at the same time as LRCLK edge and captured at the next rising edge of SCLK.
- If LRCLK phase changes by more than 10MCLK, the codec automatically resets.

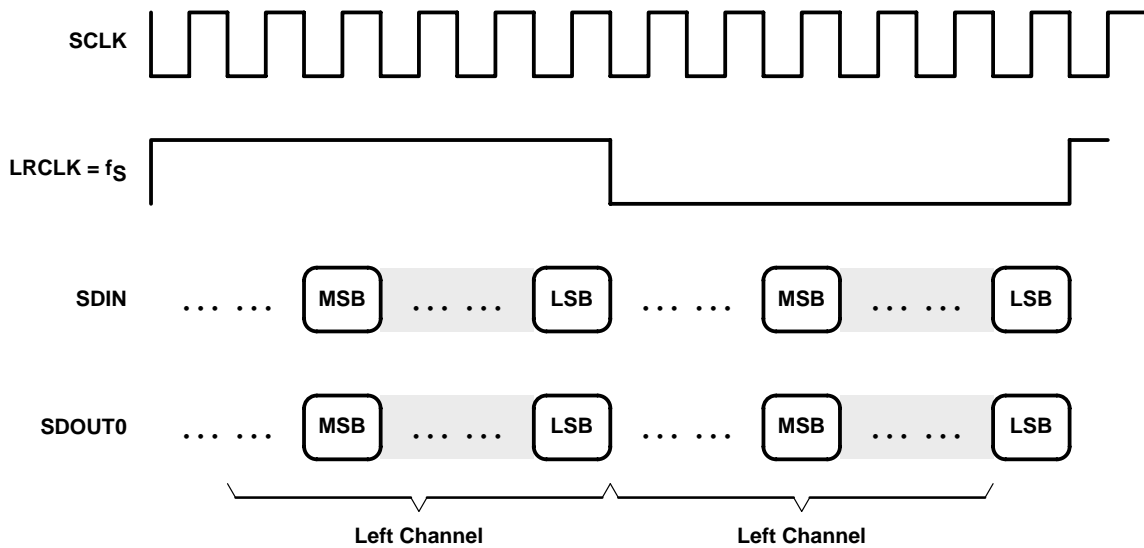

Figure 2–4. MSB First, Right-Justified Serial Interface Format—Monaural ADC Mode, B Left Input Selected

### 2.3.2 I<sup>2</sup>S Serial Interface Format—Monaural ADC Mode, B Left Input Selected

The monaural output mode for the I<sup>2</sup>S serial interface format is for 16, 18, 20, and 24 bits with the following bits in the analog control register set as shown:

- Bit 7 (ADM) is set to 1.
- Bit 6 (LRB) is cleared to 0.
- Bit 1 (INP) is set to 1.

Figure 2–5 shows the following characteristics of this protocol:

- Left channel is transmitted when LRCLK is either high or low.
- SDIN is sampled with the rising edge of SCLK.
- SDOUT is transmitted on the falling edge of SCLK.
- If LRCLK phase changes by more than 10MCLK, the codec automatically resets.

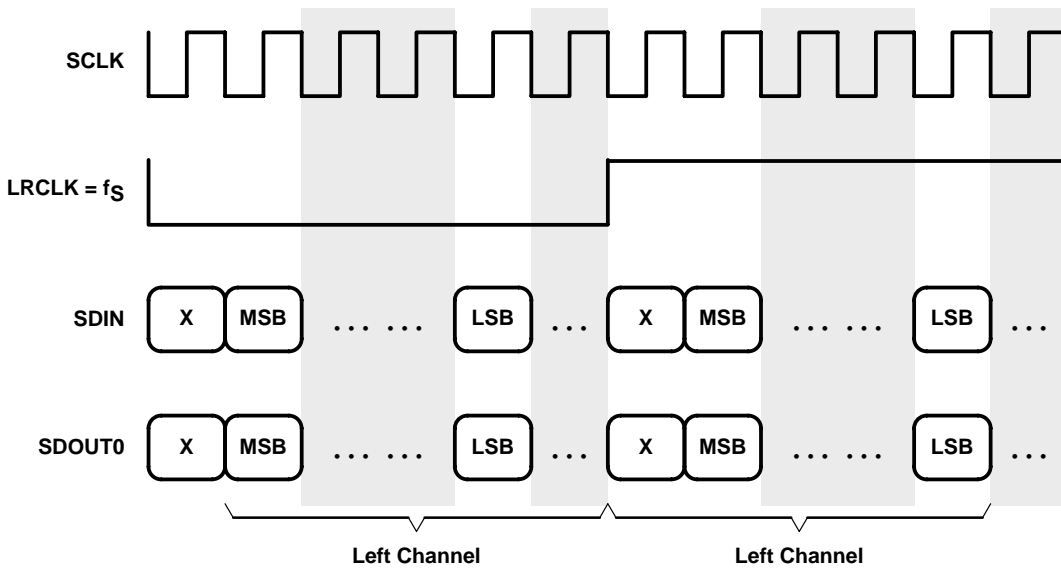

Figure 2–5. I<sup>2</sup>S Serial Interface Format—Monaural ADC Mode, B Left Input Selected

### 2.3.3 MSB Left-Justified Serial Interface Format—Monaural ADC Mode, B Left Input Selected

The monaural output mode for the MSB left-justified serial interface format is for 16, 18, 20, and 24 bits with the following bits in the analog control register set as shown:

- Bit 7 (ADM) is set to 1.
- Bit 6 (LRB) is cleared to 0.
- Bit 1 (INP) is set to 1.

Figure 2–6 shows the following characteristics of this protocol:

- Left channel is transmitted when LRCLK is either high or low.
- The SDIN data is justified to the leading edge of the LRCLK.
- The MSBs are transmitted at the same time as LRCLK edge and captured at the next rising edge of SCLK.

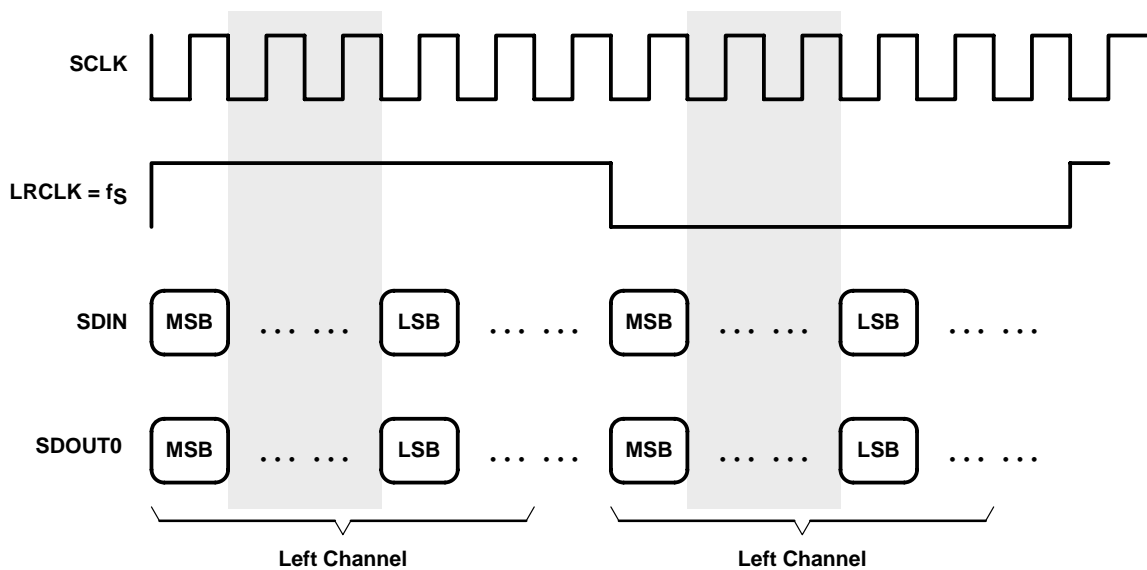

Figure 2–6. MSB Left-Justified Serial Interface Format—Monaural ADC Mode, B Left Input Selected

### 2.3.4 MSB First, Right-Justified Serial Interface Format—Monaural ADC Mode, B Right Input Selected

The monaural output mode for the MSB first, right-justified serial interface format is for 16, 18, 20, and 24 bits with the following bits in the analog control register set as shown:

- Bit 7 (ADM) is set to 1.
- Bit 6 (LRB) is set to 1.
- Bit 1 (INP) is set to 1.

Figure 2–7 shows the following characteristics of this protocol:

- Right channel is transmitted when LRCLK is either high or low.
- The SDIN(s) (recorded) data is justified to the trailing edge of the LRCLK.
- The SDOUT(s) MSB (playback) data is transmitted at the same time as LRCLK edge and captured at the next rising edge of SCLK.
- If LRCLK phase changes by more than 10MCLK, the codec automatically resets.

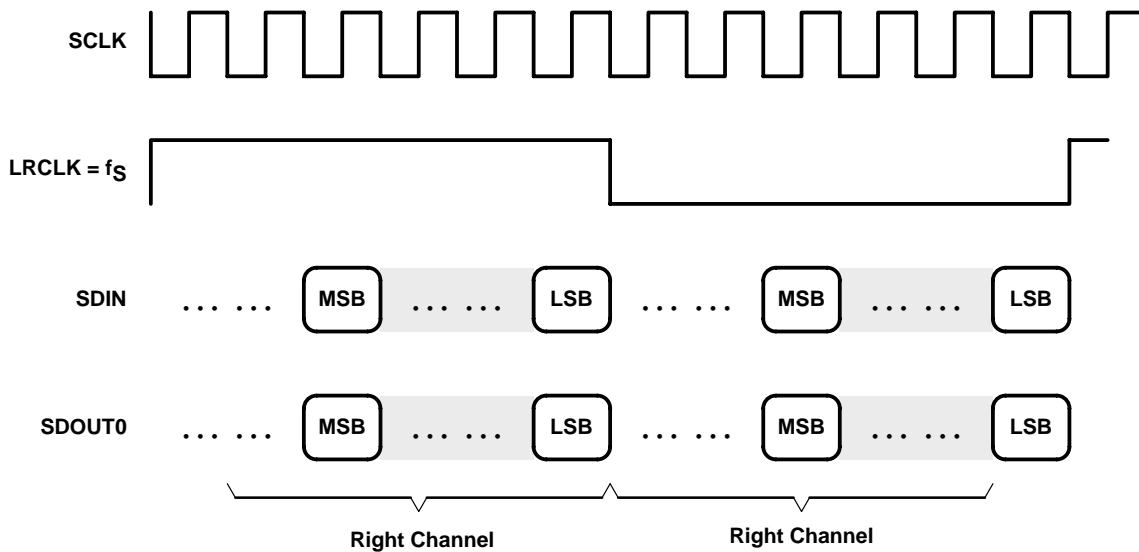

Figure 2–7. MSB First, Right-Justified Serial Interface Format—Monaural ADC Mode, B Right Input Selected

### 2.3.5 I<sup>2</sup>S Serial Interface Format—Monaural ADC Mode, B Right Input Selected

The monaural output mode for the I<sup>2</sup>S serial interface format is for 16, 18, 20, and 24 bits with the following bits in the analog control register set as shown:

- Bit 7 (ADM) is set to 1.
- Bit 6 (LRB) is set to 1.
- Bit 1 (INP) is set to 1.

Figure 2–8 shows the following characteristics of this protocol:

- Right channel is transmitted when LRCLK is either high or low.
- SDIN is sampled with the rising edge of SCLK.
- SDOUT is transmitted on the falling edge of SCLK.
- If LRCLK phase changes by more than 10MCLK, the codec automatically resets.

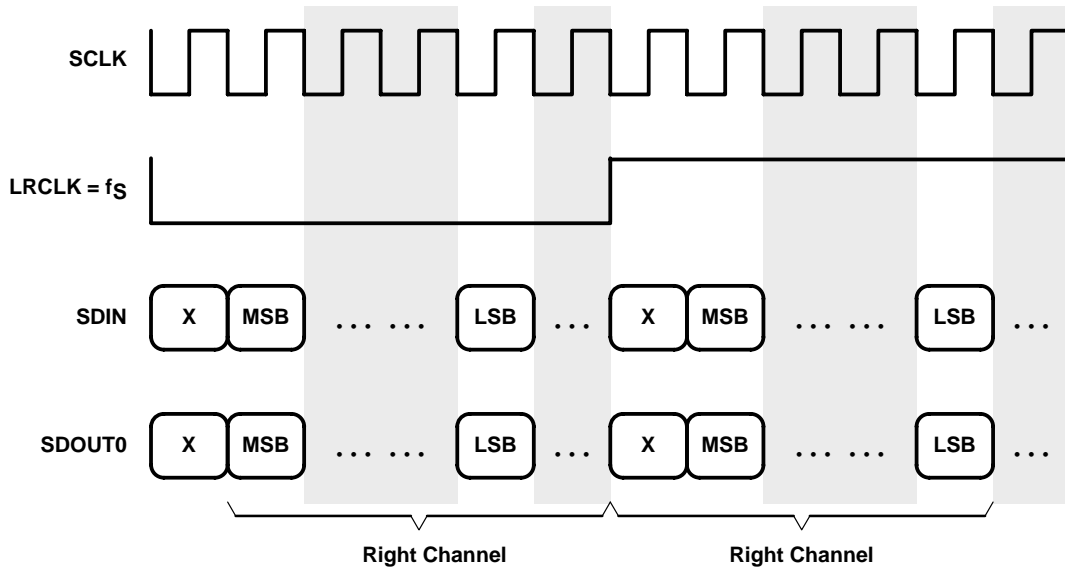

Figure 2–8. I<sup>2</sup>S Serial Interface Format—Monaural ADC Mode, B Right Input Selected

### 2.3.6 MSB Left-Justified Serial Interface Format—Monaural ADC Mode, B Right Input Selected

The monaural output mode for the MSB left-justified serial interface format is for 16, 18, 20, and 24 bits with the following bits in the analog control register set as shown:

- Bit 7 (ADM) is set to 1.
- Bit 6 (LRB) is set to 1.
- Bit 1 (INP) is set to 1.

Figure 2–9 shows the following characteristics of this protocol:

- Right channel is transmitted when LRCLK is either high or low.
- The SDIN data is justified to the leading edge of the LRCLK.
- The MSBs are transmitted at the same time as LRCLK edge and captured at the next rising edge of SCLK.

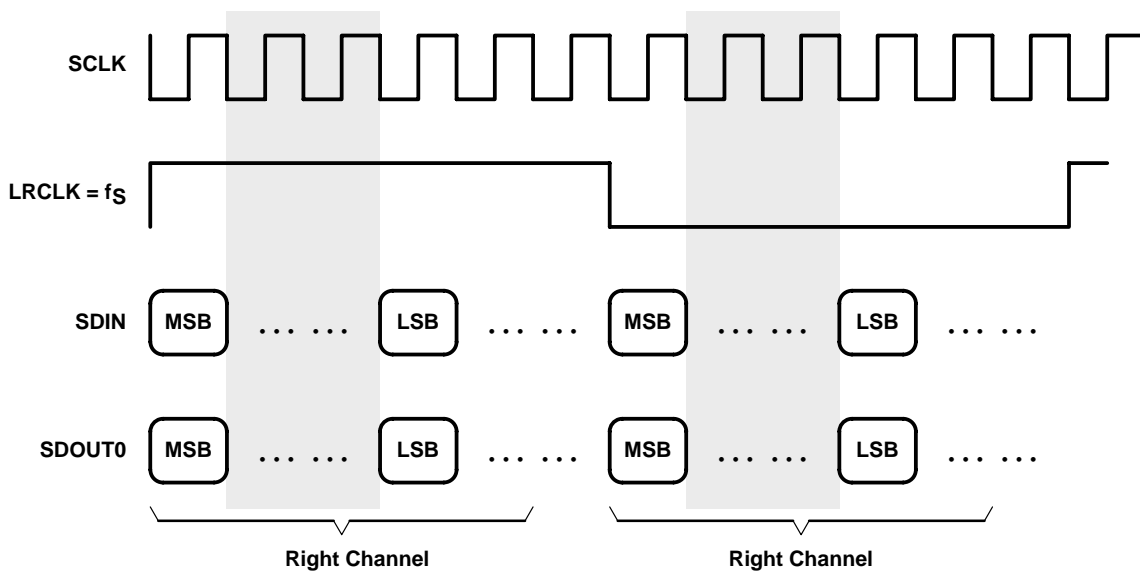

Figure 2–9. MSB Left-Justified Serial Interface Format—Monaural ADC Mode, B Right Input Selected

## 2.4 Switching Characteristics

PARAMETER		MIN	TYP	MAX	UNIT
$t_c(\text{SCLK})$	SCLK frequency			3.072	MHz
$t_d(\text{SLR})$	SCLK rising to LRCLK edge	20			ns
$t_d(\text{SDOUT})$	SDOUT valid from SCLK falling (see Note 1)			$(1/256f_s) + 10$	ns
$t_{su}(\text{SDIN})$	SDIN setup before SCLK rising edge	20			ns
$t_h(\text{SDIN})$	SDIN hold after SCLK rising edge	100			ns
LRCLK		32	44.1	48	kHz
Duty cycle			50		%

NOTE 1: Maximum of 50-pF external load on SDOUT.

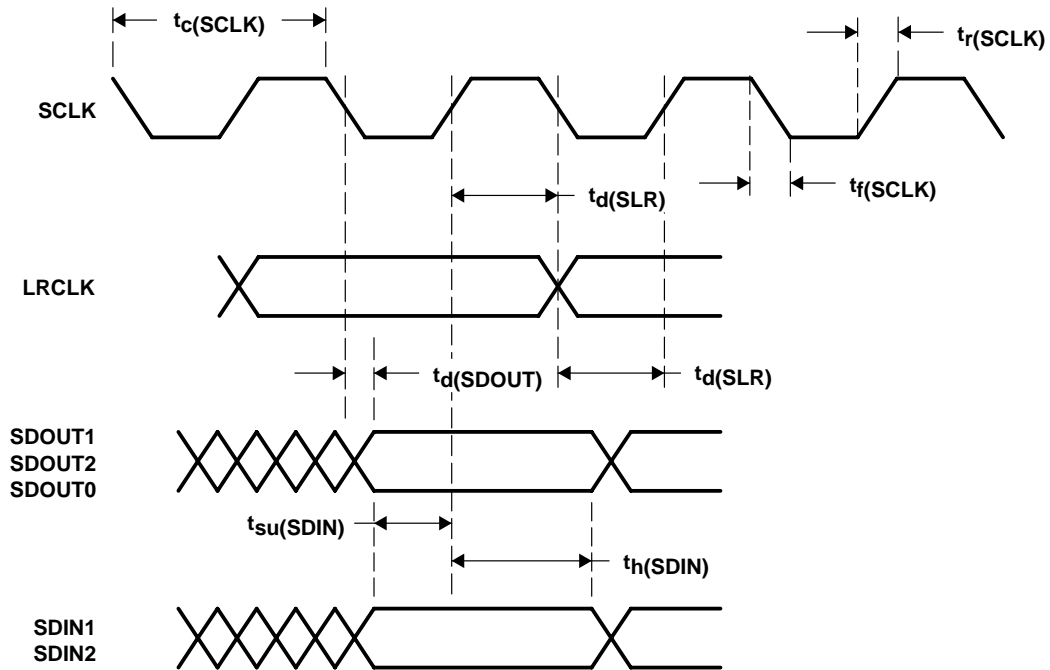

Figure 2–10. For Right-/Left-Justified, I<sup>2</sup>S, and Left-/Left-Justified Serial Protocols



### 3 Analog Input/Output

The TAS3004 device contains a stereo 24-bit ADC with two single-ended inputs per channel. Selection of the A or B analog input is accomplished by setting a bit in the analog control register (ACR) by an I<sup>2</sup>C command. Additionally, the TAS3004 device has a stereo 24-bit digital-to-analog converter (DAC).

#### 3.1 Analog Input

Figure 3–1 shows the technique and components required for analog input to the TAS3004 device. The maximum input signal must not exceed  $0.7 V_{rms}$ . Selection of the above component values gives a frequency response from 20 Hz to 20 kHz at a sampling frequency of 48 kHz without alias frequency problems.

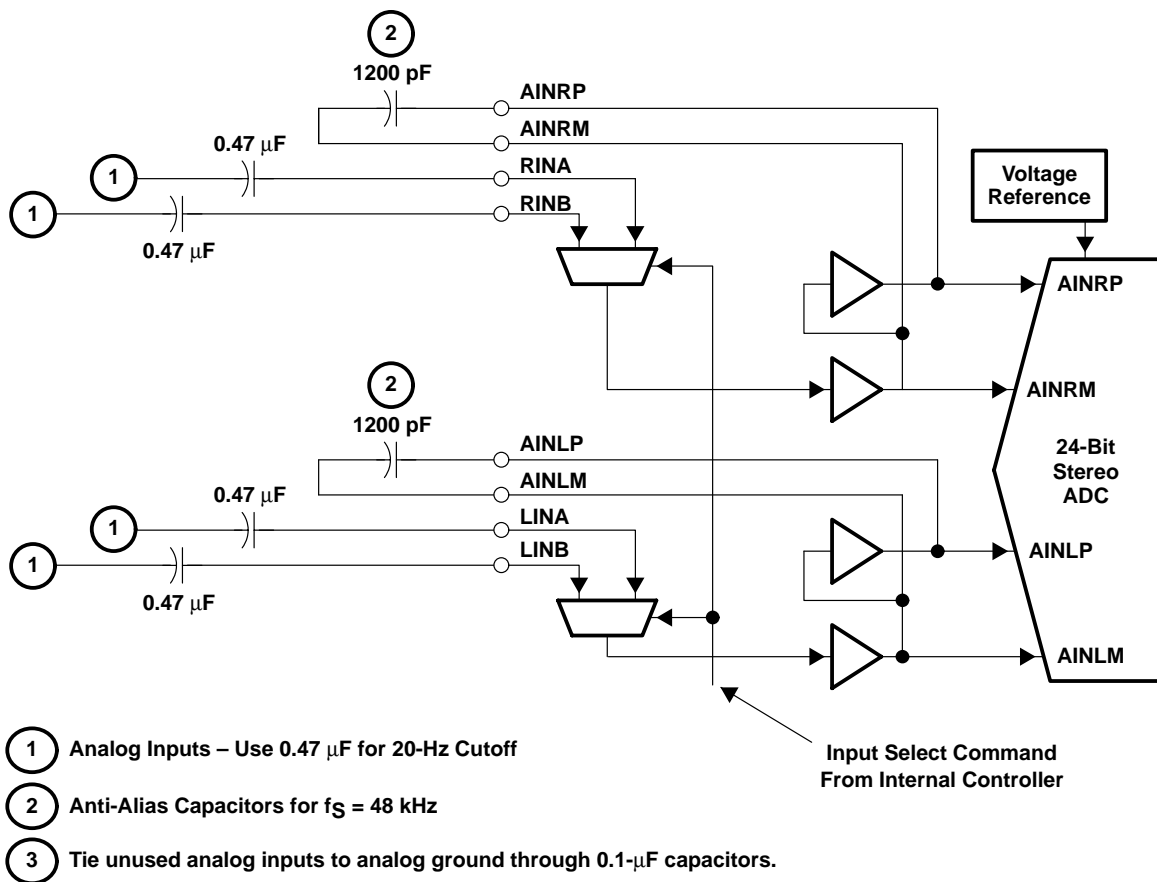

Figure 3–1. Analog Input to the TAS3004 Device

#### 3.2 Analog Output

##### 3.2.1 Analog Output

The full scale analog output from the TAS3004 device is  $0.7 V_{rms}$ . It is referenced to VCOM which is approximately 1.5 Vdc. VCOM must be decoupled with the network as shown in Figure 3–2.

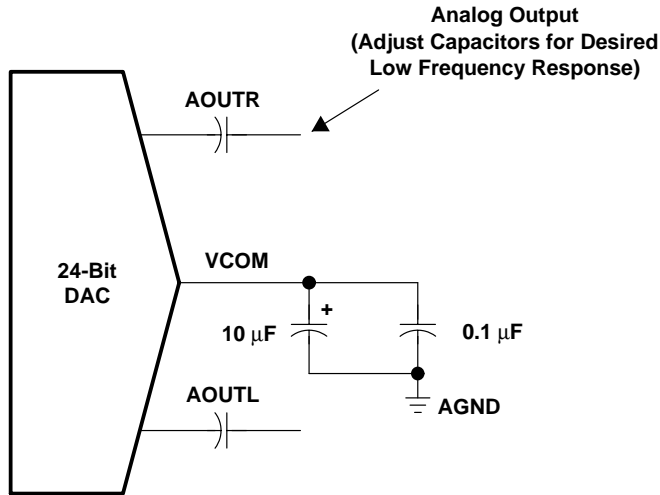

Figure 3-2. VCOM Decoupling Network

### 3.2.2 Analog Output With Gain

Since the analog output from the TAS3004 device is  $0.7 V_{rms}$ , the output level can be increased by using an external amplifier. The circuit shown in Figure 3-3 boosts the output level to  $1 V_{rms}$  (when it has a gain of 1.414) and provides improved signal-to-noise ratio (SNR). Since this circuit lowers the noise floor, THD + N is improved also.

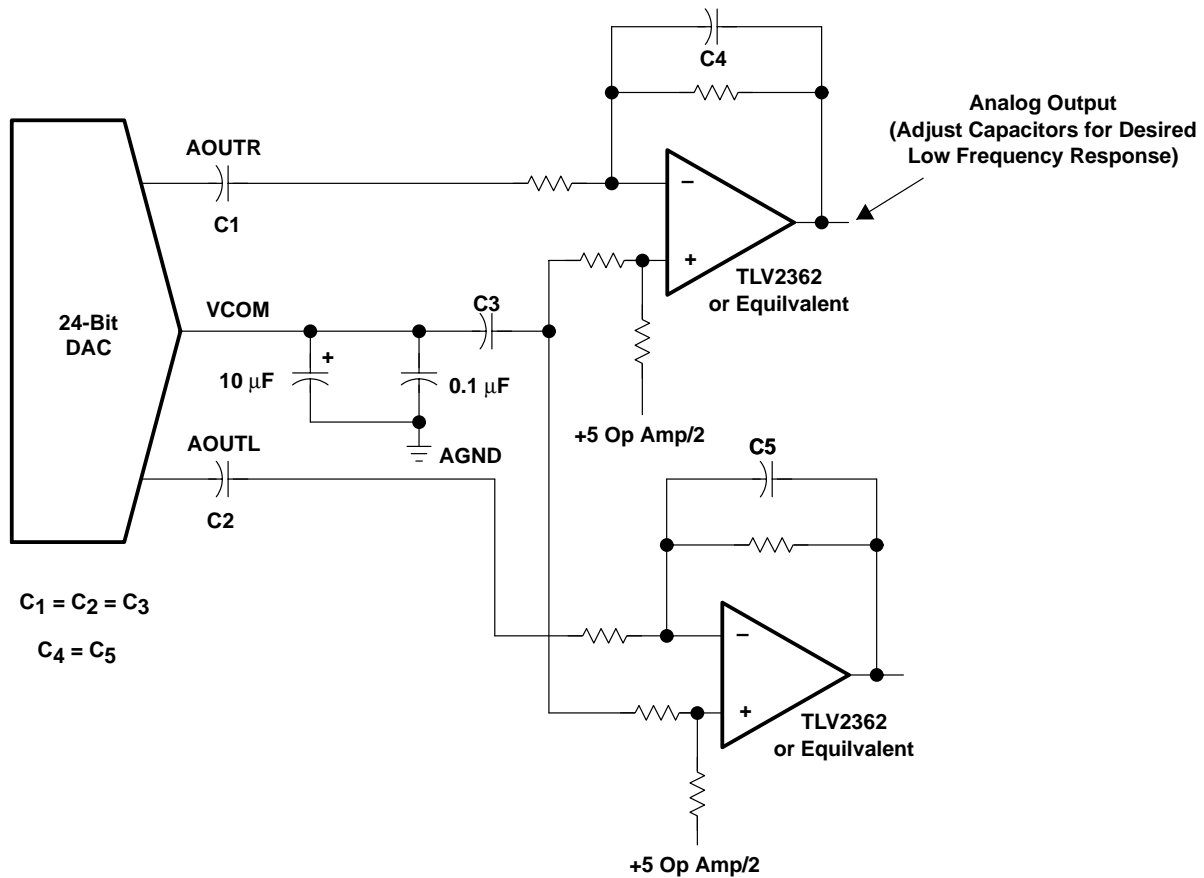

Figure 3-3. Analog Output With External Amplifier

### 3.2.3 Reference Voltage Filter

Figure 3–4 shows the TAS3004 reference voltage filter.

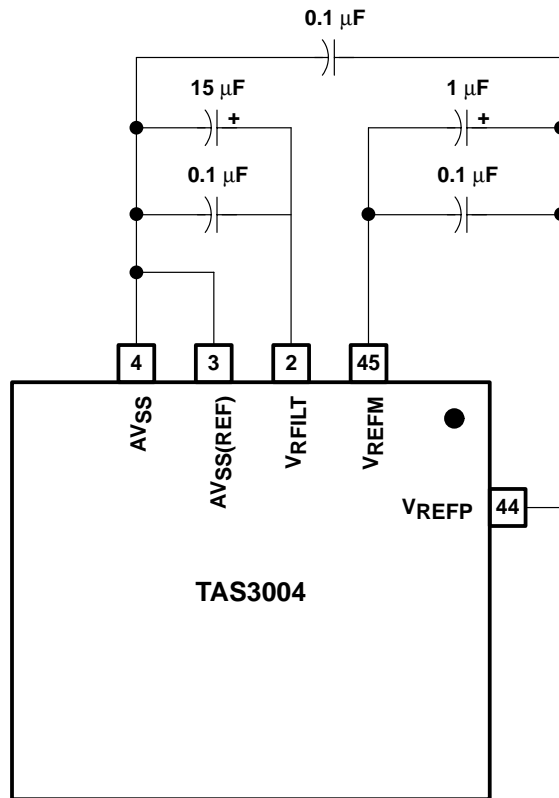

Figure 3–4. TAS3004 Reference Voltage Filter



## 4 Audio Control/Enhancement Functions

### 4.1 Soft Volume Update

The TAS3004 device implements a TI proprietary soft volume update. This feature allows a smooth and pleasant-sounding change from one volume level to another over the entire range of volume control (18 dB to mute).

The volume is adjustable by downloading a 4.16 gain coefficient through the I<sup>2</sup>C interface. Table A–5 lists the 4.16 coefficients converted into dB for the range of –70 dB to 18 dB with 0.5-dB step resolution.

Right and left channel volumes can be ungangled and set to different values. This feature implements a balance control.

Volume is changed by writing the desired value into the volume control registers. This is done by asserting the GPI terminals for volume-up or volume-down for a limited range of volume control. Alternately, volume control settings can be sent to the TAS3004 device over the I<sup>2</sup>C bus.

### 4.2 Software Soft Mute

Mute is implemented by loading all zeros in the volume control register. This causes the volume to ramp down over a duration of  $2048f_s$  samples to a final output of 0 (– infinity dB).

Soft mute can be enabled by either asserting the mute GPI terminal or sending a mute command over the I<sup>2</sup>C bus.

### 4.3 Input Mixer Control

The TAS3004 device is capable of mixing and multiplexing three channels of serial audio data. The mixing is controlled through three mixer control registers. This is accomplished by loading values into the corresponding bytes of the mixer left gain (07h) and mixer right gain (08h) control registers.

The values loaded into these registers are in 4.20 format—4 bits for the integer and 20 bits for the fractional part. Table A–8 lists the 4.20 numbers converted into dB for the range of –70 dB to 18 dB, although any positive 4.20 number may be used.

To mute any of the channels, 0s are loaded into the respective mixer control register.

Mixer controls are updated instantly and can cause audible artifacts for large changes in setting when updated dynamically outside of the fast load mode; therefore, it is desirable to use fast load in conjunction with the soft-volume mode.

SDIN1, SDIN2, and the ADC output can be mixed with a user-selectable gain for each channel. The gain control registers are represented in 4.20 format.

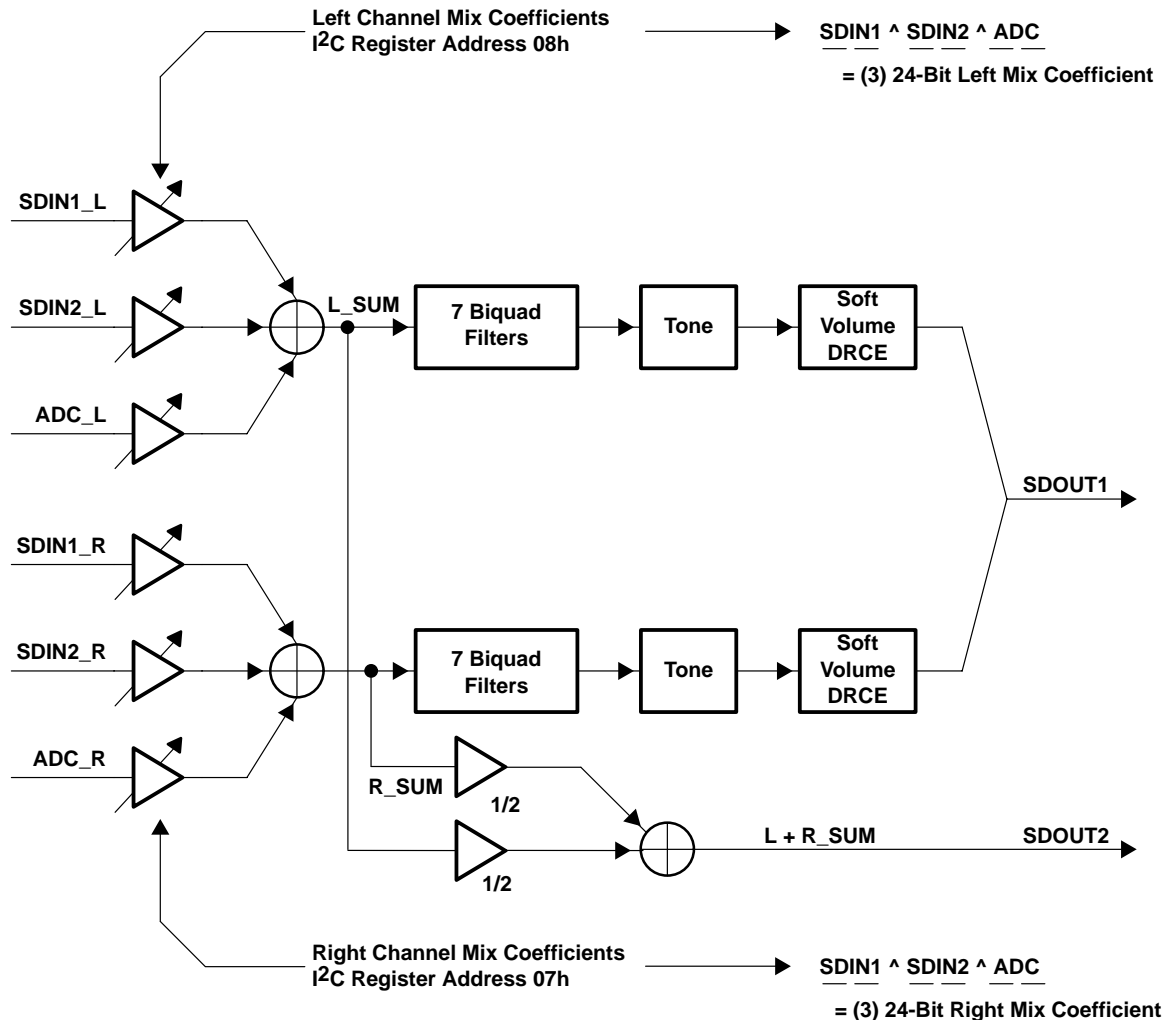

Figure 4–1. TAS3004 Mix Function

#### 4.4 Mono Mixer Control

The TAS3004 device contains a second mixer that performs the function of mixing left and right channel digital audio data from the input mixer in order to derive a monaural channel. This mixer has a fixed gain of –6 dB so that full scale inputs on L\_sum and R\_sum do not produce clipping on the resulting L+R\_sum.

The output of this mixer is present on terminal 24 (SDOUT2) and is generally used for a digitally-mixed subwoofer or center channel application.

#### 4.5 Treble Control

The treble gain level may be adjusted within the range of 15 dB to –15 dB with 0.5-dB step resolution. The level changes are accomplished by downloading treble codes (shown in Appendix A) into the treble gain register. Alternately, a limited range of treble control is available by asserting the GPI terminals.

The treble control has a corner frequency of 6 kHz at a 48-kHz sample rate.

The gain values for treble control can be found in Section A.3.

## 4.6 Bass Control

The bass gain level can be adjusted within the range of 15 dB to –15 dB with 0.5-dB step resolution. The level changes are accomplished by downloading bass codes (shown in Appendix A) into the bass frequency control register. Alternately, a limited range of bass control is available by asserting the GPI terminals.

Bass control is a shelf filter with a corner frequency of 250 Hz at a 48-kHz sample rate.

The gain values for bass control can be found in Section A.4.

## 4.7 De-Emphasis (DM)

De-emphasis is implemented in the DAC and is software controlled. De-emphasis is valid at 44.1 kHz and 48 kHz.

To enable de-emphasis, values are written into the analog control register via the I<sup>2</sup>C command. See Section 4.8 for analog control register operation.

Figure 4–2 illustrates the frequency response of the de-emphasis mode.

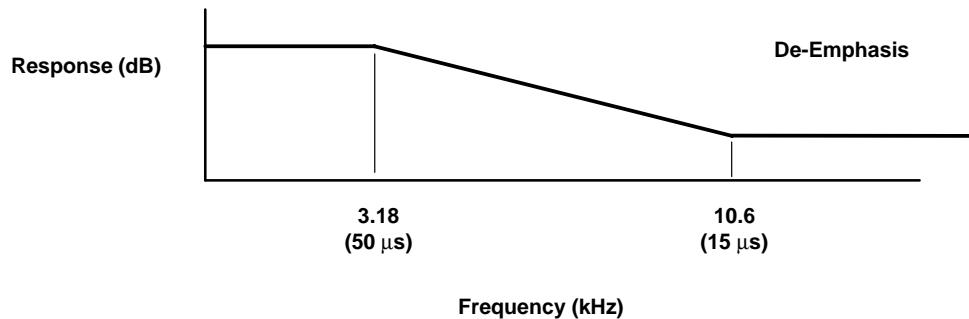

**Figure 4–2. De-Emphasis Mode Frequency Response**

## 4.8 Analog Control Register Operation

The analog control register (ACR) allows control of de-emphasis, selection of the analog input channel to the ADC, and analog power down.

An I<sup>2</sup>C master is required to write the appropriate command into the ACR. The ACR subaddress is 0x40.

Bit	7	6	5	4	3	2	1	0
Type	R/W	R/W	R/W	R/W	R/W	R/W	R/W	R/W
Default	0	0	0	0	0	0	0	0

**Table 4–1. Analog Control Register Description**

BIT	FIELD NAME	TYPE	DESCRIPTION
7	ADM	R/W	ADC output mode. 0 = Normal operation 1 = A inputs are normal; B inputs are monaural.
6	LRB	R/W	Selects left or right B input for monaural output. 0 = B left input selected for monaural ADC output when bit 7 (ADM) is set to 1. 1 = B right input selected for monaural ADC output when bit 7 (ADM) is set to 1.
5–4	RSVD	R/W	Reserved. Bits 5 and 4 return 0s when read.
3–2	DM(1–0)	R/W	De-emphasis control. 00 = De-emphasis off (initial condition after reset) 01 = 48 kHz sample rate de-emphasis selected 10 = 44.1 kHz sample rate de-emphasis selected 11 = Reserved
1	INP	R/W	Analog input select. 0 = LINA and RINA selected (initial condition after reset) 1 = LINB and RINB selected
0	APD	R/W	Analog powerdown. 0 = Normal operation (initial condition after reset) 1 = Powerdown

## 4.9 Dynamic Loudness Contour

The necessity for applying loudness compensation to playback systems to compensate for the fact that the ear perceives bass and treble less audibly at low levels than at high ones has been established with the first data published by Fletcher and Munson in 1933.

There are many equal-loudness contours in publication, like Steven's contours, Robinson and Dadson contours even reached the acceptance level of ISO recommendation.

The TAS3004 device has a simplified loudness contour algorithm that diminishes the effect of weak bass at low listening levels. Since contour has volume level dependency, the user must define the relation between the gain of the contour circuit and the volume level.

Figure 4–3 is a block diagram of this circuit.

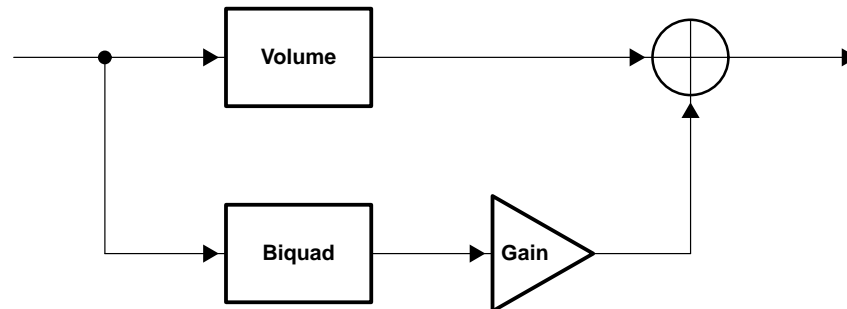

**Figure 4–3. Block Diagram**

The loudness contour is activated by sending an activation command via I<sup>2</sup>C from an external device. Optionally, a contour gain command can be sent by an external device to provide tracking with the system's volume control.

### 4.9.1 Loudness Biquads

Loudness biquad filters for the left and right channels are independently programmable via I<sup>2</sup>C. Their subaddresses are 0x21 and 0x22, respectively. The digital filters are written as five 24-bit (4.20) hex coefficients for each channel.

### 4.9.2 Loudness Gain

Loudness gain values for the left and right channels are independently programmable via I<sup>2</sup>C. Their subaddresses are 0x23 and 0x24, respectively. The gain values are written as one 4.20 hex coefficient for each channel.

### 4.9.3 Loudness Contour Operation

When the frequency of the loudness contour is determined, a digital filter must be developed. Then, the gain of the filter is determined. These values are placed in the storage area of the system controller (microcontroller) and sent to the TAS3004 device when it is desired to activate the loudness contour.

If it is necessary to change the frequency or gain of the contour, new gain and filter coefficients are sent by the system controller. This function is performed normally when the volume control is changed (that is, more volume, less contour). The gain of the loudness contour filter then tracks the volume control.

The loudness contour biquad filters are provided in addition to the seven equalization biquad filters.

See Section A.6 for programming instructions.

## 4.10 Dynamic Range Compression/Expansion

The TAS3004 device provides the user with the ability to manage the dynamic range of the audio system. The DRCE receives data, and affects scaling after the volume/loudness block. As shown in Figure 4–4, the DRCE is applied after the volume/loudness control block as a DRCE scale factor. The DRCE must be adjusted such that the signal does not reach the hard limit value. However, if the signal does reach the maximum digital value, the saturation logic serves as a hard limiter that does not allow the signal to extend beyond the available range.

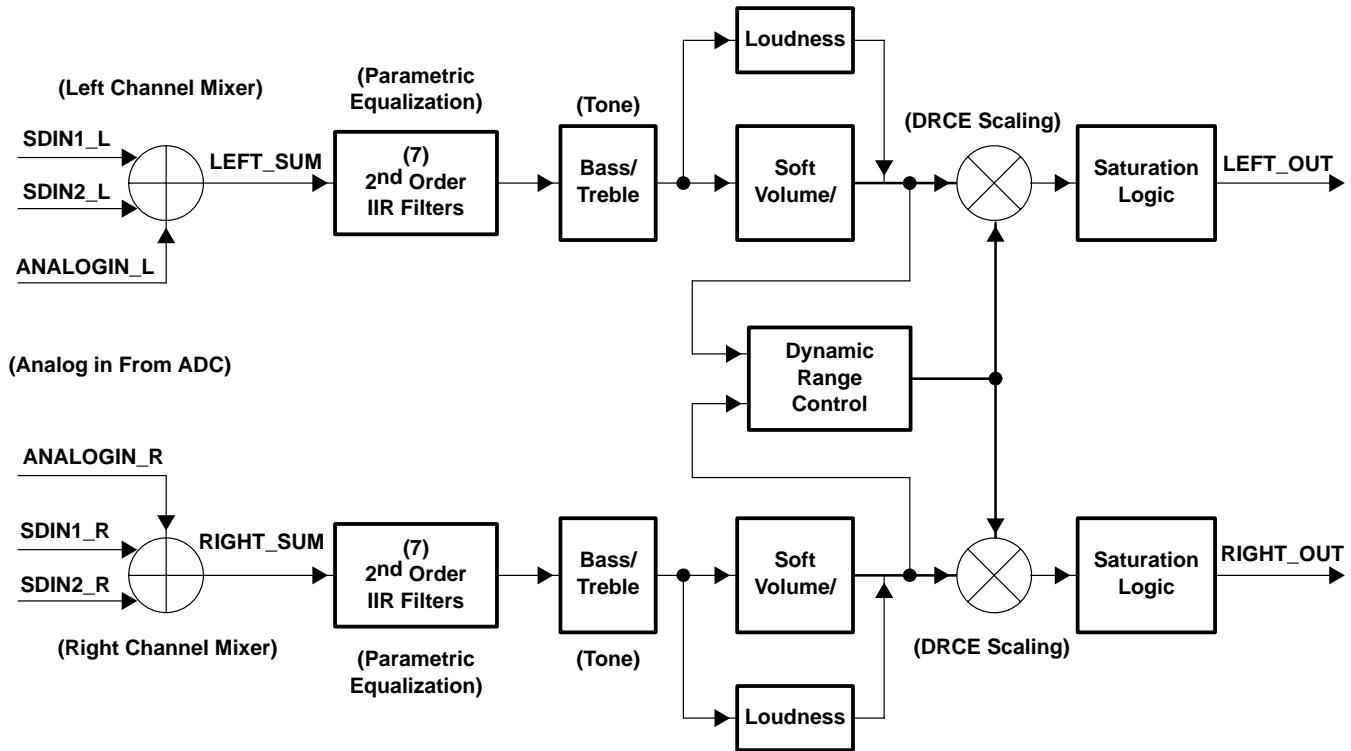

Figure 4–4. TAS3004 Digital Signal Processing Block Diagram

The DRCE instruction consists of eight bytes that must be sent each time in the order shown in the example code of Table A–9. Each instruction downloaded must be eight bytes. If only one byte is changed, all eight bytes must be transmitted. The first two bytes remain the same for every instruction, however the last six bytes can be programmed using hexadecimal values from the corresponding tables referred to in Section A.7.

With high compression ratios and fast attack times available, this function is suited for a commercial killer in a television set application.

## 4.11 AllPass Function

This function is enabled by setting terminal 27 (ALLPASS) on the TAS3004 device to 1. When asserted, the internal equalization filters are set into AllPass (flat) mode. When this terminal is reset to 0, the equalization filters are returned to the equalization that was in use before the terminal was asserted.

In AllPass mode, the bass and treble controls are still functional.

This function is frequently used for headphones. When the headphone plug is inserted into its jack, a switched contact in the jack enables the AllPass function.

The AllPass function also can be activated by writing a 1 to bit 2 of the analog control register.

## 4.12 Main Control Register 2 (43h)

The TAS3004 device contains two main control registers: main control register 1 (MCR1) and main control register 2 (MCR2). The MCR2 contains the bits associated with the AllPass function and the download of bass and treble control information, and it is accessed via I<sup>2</sup>C with the address 43h.

MCR2 (43h)

Bit	b7	b6	b5	b4	b3	b2	b1	b0
Type	R/W	R	R	R	R	R	R/W	R
Default	0	0	0	x	x	x	0	0

**Table 4–2. Main Control Register 2 Description**

BIT	TYPE	DESCRIPTION
b7	R/W	0 = Normal operation (initial condition after reset) 1 = Download bass and treble
b6–b5	R	Reserved. Bits b6 and b5 return 0s when read.
b4–b2	R	Undefined.
b1	R/W	0 = Normal operation (initial condition after reset) 1 = AllPass mode (bass and treble are still functional)
b0	R	Reserved. Bit b0 returns 0 when read.



## 5 Filter Processor

### 5.1 Biquad Block

The biquad block consists of seven digital biquad filters per channel organized in a cascade structure, as shown in Figure 5–1. Each of these biquad filters has five downloadable 24-bit (4.20) coefficients. Each stereo channel has independent coefficients.

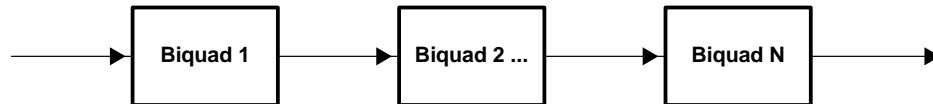

Figure 5–1. Biquad Cascade Configuration

#### 5.1.1 Filter Coefficients

The filter coefficients for the TAS3004 device are downloaded through the I<sup>2</sup>C port and loaded into the biquad memory space. Each biquad filter memory space has an independent address. Digital audio data coming into the device is processed by the biquad block and then converted into analog waveforms by the DAC. Alternately, filters can be loaded by asserting terminals on the GPI port.

#### 5.1.2 Biquad Structure

The biquad structure that is used for the parametric equalization filters is as follows:

$$H(z) = \frac{b_0 + b_1z^{-1} + b_2z^{-2}}{a_0 + a_1z^{-1} + a_2z^{-2}} \quad (1)$$

**NOTE:**  $a_0$  is fixed at value 1 and is not downloadable.

The coefficients for these filters are represented in 4.20 format—4 bits for the integer part and 20 bits for the fractional part. In order to transmit them over I<sup>2</sup>C, it is necessary to separate each coefficient into three bytes. The upper 4 bits of byte 2 is the integer part, and the second nibble of byte 2, byte 1, and byte 0 are the fractional parts.

The filters can be designed using the automatic loudspeaker equalization program (ALE) or a script running under MatLab named Filtermaker. Both of these tools are available from Texas Instruments.



## 6 I<sup>2</sup>C Serial Control Interface

### 6.1 Introduction

Control parameters for the TAS3004 device can be loaded from an I<sup>2</sup>C serial EPROM by using the TAS3004 master interface mode. If no EPROM is found, the TAS3004 device becomes a slave device and loads from another I<sup>2</sup>C master interface. Information loaded into the TAS3004 registers is defined in Appendix A.

The I<sup>2</sup>C bus uses terminals 16 (SDA for data) and 15 (SCL for clock) to communicate between integrated circuits in a system. These devices can be addressed by sending a unique 7-bit slave address plus R/W bit (1 byte). All compatible devices share the same terminals via a bidirectional bus using a wired-AND connection. An external pullup resistor must be used to set the high level on the bus. The TAS3004 device operates in standard mode up to 100 kbps with as many devices on the bus as desired up to the capacitance load limit of 400 pF.

Furthermore, the TAS3004 device supports a subset of the SMBus protocol. When it is attached to the SMBUS, then byte, word, and block transfers are supported. The SMBus NAK function is not supported and care must be taken with the sequence of the instructions sent to the TAS3004 device.

Additionally, the TAS3004 device operates in either master or slave mode; therefore, at least one device connected to the I<sup>2</sup>C bus must operate in master mode.

### 6.2 I<sup>2</sup>C Protocol

The bus standard uses transitions on SDA while the clock is high to indicate start and stop conditions. A high-to-low transition on SDA indicates a start and a low-to-high transition indicates a stop. Normal data bit transitions must occur within the low time of the clock period. Figure 6–1 shows these conditions. These start and stop conditions for the I<sup>2</sup>C bus are required by standard protocol to be generated by the master. The master must also generate the 7-bit slave address and the read/write (R/W) bit to open communication with another device and then wait for an acknowledge condition. The slave holds SDA low during acknowledge clock period to indicate an acknowledgment. When this occurs, the master transmits the next byte of the sequence.

After each 8-bit word, an acknowledgment must be transmitted by the receiving device. There is no limit on the number of bytes that can be transmitted between start and stop conditions. When the last word transfers, the master generates a stop condition to release the bus. Figure 6–1 shows a generic data transfer sequence.

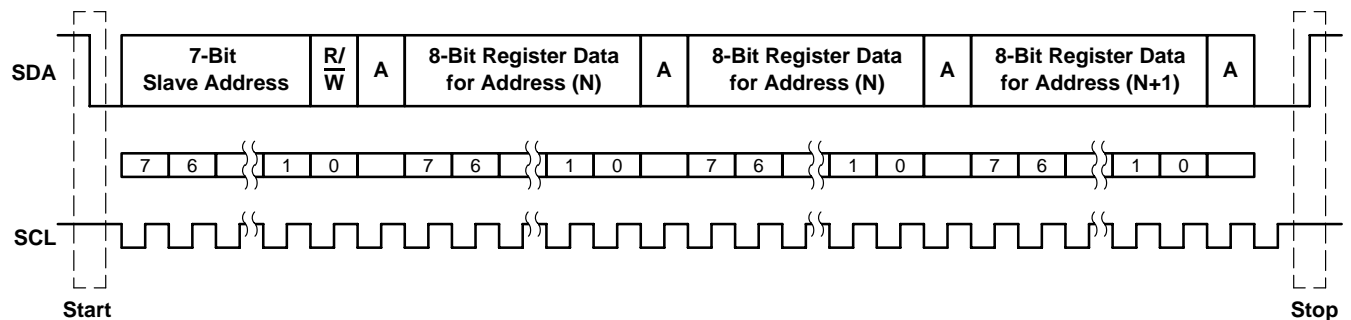

Figure 6–1. Typical I<sup>2</sup>C Data Transfer Sequence

Table 6–1 lists the definitions used by the I<sup>2</sup>C protocol.

**Table 6–1. I<sup>2</sup>C Protocol Definitions**

DEFINITION	DESCRIPTION
Transmitter	The device that sends data
Receiver	The device that receives data
Master	The device that initiates a transfer, generates clock signals, and terminates the transfer
Slave	The device addressed by the master
Multimaster	More than one master can attempt to control the bus at the same time without corrupting the message.
Arbitration	Procedure to ensure the message is not corrupted when two masters attempt to control the bus.
Synchronization	Procedure to synchronize the clock signals of two or more devices

### 6.3 Operation

The 7-bit address for the TAS3004 device is 011010X  $\overline{R/W}$  where X is a programmable address bit, set by terminal 7 (CS1). Combining CS1 and the  $\overline{R/W}$  bit, the TAS3004 device can respond to four different I<sup>2</sup>C addresses (two read and two write). These two addresses are licensed I<sup>2</sup>C addresses that do not conflict with other licensed I<sup>2</sup>C audio devices. In addition to the 7-bit device address, subaddresses direct communication to the proper memory location within the device. A complete table of subaddresses and control registers is provided in Appendix A. For example, to change bass to 10-dB gain, Section 6.3.1 shows the data that is written to the I<sup>2</sup>C port:

**Table 6–2. I<sup>2</sup>C Address Byte Table**

I <sup>2</sup> C ADDRESS BYTE	A6–A1	CS1 (A0)	$\overline{R/W}$
0x68	011010	0	0
0x69	011010	0	1
0x6A	011010	1	0
0x6B	011010	1	1

#### 6.3.1 Write Cycle Example

Start	Slave Address	$\overline{R/W}$	A	Subaddress	A	Data	A	Stop
-------	---------------	------------------	---	------------	---	------	---	------

FUNCTION	DESCRIPTION
Start	Start condition as defined in I <sup>2</sup> C
Slave address	0110100 (CS1 = 0)
$\overline{R/W}$	0 (write)
A	Acknowledgement as defined in I <sup>2</sup> C (slave)
Subaddress	00000110 (see Appendix A)
Data	00011100 (see Appendix A)
Stop	Stop condition as defined in I <sup>2</sup> C

NOTE: Table is for serial data (SDA); serial clock (SCL) is not shown but conditions apply as well.

Whenever writing to a subaddress, the correct number of data bytes must follow in order to complete the write cycle. For example, if the volume control register with subaddress 04 (hex) is written to, six bytes of data must follow; otherwise, the cycle is incomplete and errors occur.

### 6.3.2 TAS3004 I<sup>2</sup>C Readback Example

The TAS3004 will save in a Stack or First-In First-Out (FIFO) buffer the last 7 bytes that were sent to it. When an I<sup>2</sup>C read command is sent to the device (LSB=high), it answers by popping the first byte off the stack. The TAS3004 will then expect either a SendAck command or an I<sup>2</sup>C Stop command from the host. If a SendAck command is sent from the host then the TAS3004 will pop another byte off the stack. If an I<sup>2</sup>C Stop is sent then the TAS3004 will end this transaction. The proper sequence for reading is described as follows:

I <sup>2</sup> C Start
Send I <sup>2</sup> C address byte with read Bit Set to 1 (LSB set equal to 1)
receive Byte 0
Send Ack
receive Byte 1
Send Ack
receive Byte 2
Send Ack
receive Byte 3
Send Ack
receive Byte 4
Send Ack
receive Byte 5
Send Ack
receive Byte 6 (if you send an ACK after Byte 6 it will lock up the TAS3004)
I <sup>2</sup> C Stop

Where:

- I<sup>2</sup>C Start is a valid I<sup>2</sup>C Start Command
- Receive Byte is a valid I<sup>2</sup>C Command which reads a byte from the TAS3004.
- SendAck is a valid I<sup>2</sup>C Command that informs the TAS3004 that a byte has been read.
- I<sup>2</sup>C Stop is a valid I<sup>2</sup>C Stop Command

NOTES: 1. The TAS3004 will appear to be locked up, if a SendACK is issued after the last byte read. It is required to send an I<sup>2</sup>C Stop Condition after the last byte and not a SendACK.  
 2. The I<sup>2</sup>Cstart and I<sup>2</sup>Cstop commands are the same for both I<sup>2</sup>C read and I<sup>2</sup>C write.

### 6.3.3 I<sup>2</sup>C Wait States

The TAS3004 device performs interpolation algorithms for its volume and tone controls. If a volume or tone change is sent to the part via I<sup>2</sup>C, the command sent after the volume or tone (bass and treble) change causes an I<sup>2</sup>C wait state to occur. This wait state lasts from 41 ms to 231 ms, depending on the system clock rate, the command sent, and, in the case of bass or treble, the amount of the change.

Secondly, if a long series of commands are sent to the TAS3004 device, it may occasionally create a short wait state on the order of 150 μs to 300 μs while it loads and processes the commands.

When a sample rate of 32 kHz is used, longer wait states can occur, occasionally up to 15 ms.

The preferred way to take care of wait states is to use an I<sup>2</sup>C controller that recognizes wait states. During the wait state period, it stops sending data over I<sup>2</sup>C. If this function is not available on the system controller, fixed delays can be implemented in the system software to ensure that the controller is not trying to send more data while the TAS3004 device is busy. Sending I<sup>2</sup>C data while the TAS3004 device is busy causes errors and locks up the device, which must then be reset.

Table 6–3 gives typical values of the wait states that can be expected with the various functions of the part:

**Table 6–3. I<sup>2</sup>C Wait States**

	SYSTEM SAMPLING FREQUENCY			Comment
	32 kHz	44.1 kHz	48 kHz	
Volume	62 ms	49 ms	41 ms	Not dependent on size of change
Bass	231 ms	167 ms	153 ms	0 to –18 dB, –1 dB = 0.055 T @ f <sub>S</sub>
Treble	231 ms	167 ms	153 ms	0 to –18 dB, –1 dB = 0.055 T @ f <sub>S</sub>
DRC On	300 μs	300 μs	300 μs	
Mixer	None	None	None	
Loudness	None	None	None	
Equalization	15 ms	190 μs	300 μs	Can occur with each filter

## 6.4 SMBus Operation

The TAS3004 device supports a subset of the SMBus protocol. With proper programming techniques, it is possible to use the SMBus to set up the TAS3004 device.

### 6.4.1 Block Write Protocol

The TAS3004 device supports the block write protocol that allows up to 32 bytes to be sent as a block. To send a command using this format, the most significant bit (MSB) of the TAS3004 subaddress must be set high and the subaddress (also with MSB set high) must be programmed into the SMBus command byte. This operation signals the TAS3004 device to realize that the next byte is the SMBus byte count byte. The next byte after the byte count is then entered into the device as the first byte of data.

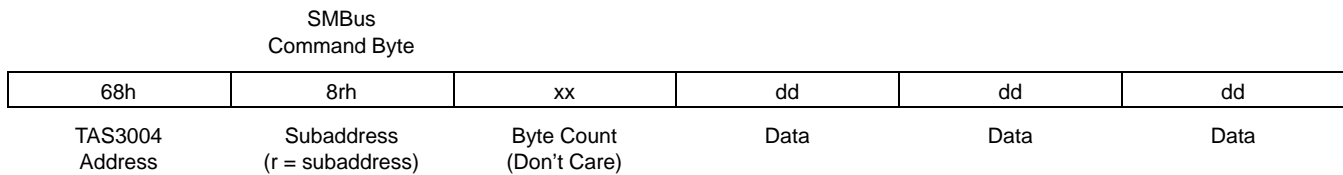

### 6.4.2 Write Byte Protocol

The TAS3004 device also supports the SMBus write byte protocol. Writing to the main control register (MCR), bass, and treble registers require using the byte write protocol. To send a command using this format, the most significant bit (MSB) of the TAS3004 subaddress must be set high and the subaddress (also with MSB set high) must be programmed into the SMBus command byte. The next byte after the command byte is then entered into the device as the first byte of data.

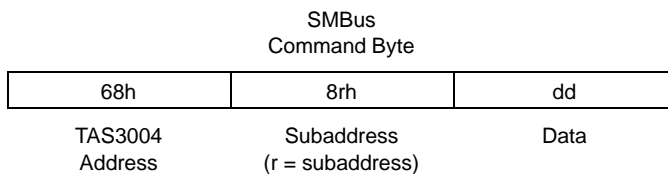

### 6.4.3 Wait States

If separate I<sup>2</sup>C/SMBus commands are sent too frequently, the TAS3004 device can generate a bus wait state. This happens when the device is busy while performing smoothing operations and changing volume, bass, and treble. The wait occurs after the bus acknowledge on the first data byte and can exceed the maximum allowable time allowed according to the SMBus specification (worst case 200 ms).

The following is a possible bus wait state scenario:

<b>CODE</b>	Start	68	84	06	01	00	00	01	00	00	Stop	
<b>ACTUAL</b>	Start	68	84	06	01	Wait†	00	00	01	00	00	Stop

† If the master does not recognize bus waiting or if the master times out on a long wait, the master must not send consecutive I<sup>2</sup>C/SMBus commands without a time interval of 200 ms between transactions.

### 6.4.4 TAS3004 SMBus Readback

The TAS3004 device supports a subset of SMBus readback. When an SMBus read command is sent to the device (LSB = high), it answers with the subaddress and the last six bytes written.

		SMBus Command Byte	Byte Count							
<b>SENT</b>	Start	69h	xxh	07h	Stop					
<b>RECEIVED</b>	Start	07h	aah	ddh	ddh	ddh	ddh	ddh	ddh	Stop

Byte  
Count

Where:

- xxh = Command byte, it is a *don't care* because the response contains only the subaddress and the last six bytes of data written to the TAS3004 device
- aah = The last subaddress accessed in the device
- ddh = Data bytes from the TAS3004 device

NOTE: Use read sequence defined in 6.3.2



## 7 Microcontroller Operation

The TAS3004 device contains an internal microcontroller programmed by Texas Instruments to perform housekeeping and interface functions. Additionally, it handles I<sup>2</sup>C communication and general purpose input functions.

### 7.1 General Description

The microcontroller uses a 256f<sub>S</sub> system clock and can access up to 8K bytes of memory. It interfaces with the digital audio interface I<sup>2</sup>C master/slave for downloading data and coefficients. It also interfaces with two internal DSPs for transferring coefficients and other information.

The TAS3004 coefficients are loaded through I<sup>2</sup>C in the master or slave mode. Standard audio processing functions (volume, bass, and treble) can be controlled/activated through external switches connected to the six GPI terminals. Upon reset, the internal microcontroller sets all coefficients and audio parameters to the default values. See Section 7.2.2 for default values.

If the TAS3004 address is 68h (ADDR\_SEL=0), it becomes the bus master device and attempts to load parameters and coefficients from the external EPROM. If no EPROM is present, the TAS3004 device remains in its default condition. If addresses other than 68h/69h are set, the TAS3004 device only operates as an I<sup>2</sup>C slave device.

If the microcontroller determines the TAS3004 device has an I<sup>2</sup>C address of 68h/69h and the EPROM is present, the microcontroller downloads coefficients from the EPROM. Once the download is complete, it enables the serial audio in the mode defined by an I<sup>2</sup>C write to the MCR to transfer data into and out of the device. Before reading the EPROM, the serial audio port defaults to I<sup>2</sup>S mode.

The TAS3004 device allows the user to update volume, bass, and treble dynamically by an I<sup>2</sup>C slave command or by a simple GPI switch input. The GPI can select volume up and down, bass/treble up and down, or digital equalizations. Up to five different equalizations (that is, flat, jazz, rock, voice, etc.) can be stored in the external EPROM. Also, DRCE, MCR1, MCR2, and loudness contour are enabled and disabled by I<sup>2</sup>C.

When the TAS3004 device operates in the I<sup>2</sup>C master mode, it echoes changes to all of its functions to other I<sup>2</sup>C addresses that are defined in its external EPROM. If no addresses are defined, it does not echo.

### 7.2 Power-Up/Power-Down Reset

#### 7.2.1 Power-Up Sequence

An active low on terminal 6 ( $\overline{\text{RESET}}$ ) while MCLK is running, resets the internal microcontroller and DSP(s).  $\overline{\text{RESET}}$  synchronizes internally and can be asserted asynchronously or with the simple RC circuit in Figure 7–1. On reset, SCL and SDA go to a high-impedance state. If the I<sup>2</sup>C address is set to 68h, approximately 400 μs after  $\overline{\text{RESET}}$  returns to a 1, the device sends a one-byte query via I<sup>2</sup>C to look for an EPROM. If an EPROM is found, it becomes an I<sup>2</sup>C master; otherwise, it becomes an I<sup>2</sup>C slave. When using address 68h in the slave mode, an external master must wait until after the EPROM query or else bus contention and improper operation occurs.

I<sup>2</sup>C address x6Ah does not query the bus for an EPROM. The address for the EPROM is xA0h.

#### 7.2.2 Reset

The TAS3004 device has an asynchronous reset terminal ( $\overline{\text{RESET}}$ ). This reset is synchronized with various clocks used in this device to generate a synchronous internal reset. Upon reset, the TAS3004 device goes through the following process:

- Clears all the RAM memory content

- Clears all the registers in the circuits
- Purges the codec
- Selects analog input A (RINA and LINA) and sets the input A active indicator ( $\overline{\text{INPA}}$ ) low.
- Initializes the equalization parameters to AllPass filters
- Sets the digital audio interface to I<sup>2</sup>S—18-bit mode
- Sets the bass/treble to 0 dB
- Sets the mixer gain to 0 dB SDIN1 and mutes both SDIN2 and analog-in
- Sets the volume to –40 dB
- Turns off all enhancement features (DRCE, etc.).
- Reads the I<sup>2</sup>C address. If the address is 68h, the device reads its EPROM. It is possible to load the user-defined bass/treble data and break points (optional). If there is no data, the device loads default bass/treble delta and break points from ROM.
- If the address is 6Ah, the device puts the I<sup>2</sup>C interface in slave mode and waits for input.

### 7.2.3 Reset Circuit

Since the TAS3004 device has an internal power-on reset (POR), in many cases, additional components are not needed to reset the device. It resets internally at approximately 80% of  $V_{DD}$ .

In the case where the system's power supplies are slow in reaching their final voltage or where there is a difference in the time the system power supplies take to become stable, the TAS3004 reset can be delayed by a simple RC circuit.

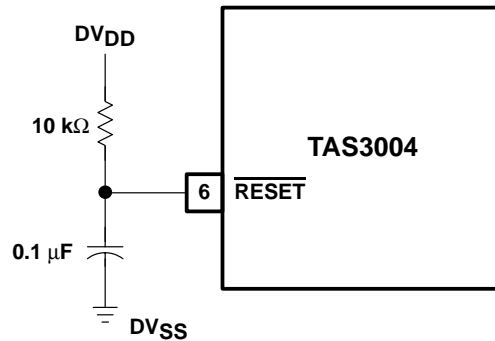

**Figure 7–1. TAS3004 Reset Circuit**

The values for the above circuit can be calculated by the simple equation:

$$t_{rd} = 0.8RC + 400 \mu s$$

Where:  $t_{rd}$  = The delay before the TAS3004 device comes out of reset

C = Value of the capacitance from  $\overline{\text{RESET}}$  (pin 6) to  $DV_{SS}$

R = Value of the resistance from  $\overline{\text{RESET}}$  (pin 6) to  $DV_{DD}$

The circuit described in Figure 7–1 delays the start-up of the TAS3004 device approximately 1.2 ms.

When it is necessary to control the reset of the TAS3004 device with an external device, such as a microcontroller,  $\overline{\text{RESET}}$  (pin 6) can be treated as a logic signal. It then brings the device out of reset when the voltage on  $\overline{\text{RESET}}$  reaches  $V_{DD}/2$ .

### 7.2.4 Fast Load Mode

While in fast load mode, it is possible to update the parametric equalization without any audio processing delay. The audio processor pauses while the RAM is updated in this mode. Bass and treble cannot download in this mode. Mixer1 and Mixer2 registers can download in this mode or normal mode (FL bit = 0).

Once the download is complete, the fast load bit must be cleared by writing a 0 into bit 7 of the main control register (MCR). This puts the TAS3004 device into normal mode.

### 7.2.5 Codec Reset

During initialization, the output of the CODEC is disabled. Throughout reset and initialization, the output of the DAC is muted to prevent extraneous noise being sent to the system output.

Data from the ADC and other internal processing is purged so that when reset/initialization is complete, only valid inputs are sent to the system output.

### 7.3 Power-Down Mode

The TAS3004 device has an asynchronous power-down mode. In the power-down mode, the internal control registers and equalization programming of the device are stored in the device.

To enter power-down mode:

- Assert the power-down control signal (1)
- Set the serial audio input clocks to 0

The TAS3004 device goes into power-down mode.

To exit the power-down mode:

- Assert  $\overline{\text{RESET}}$  (logic 0)
- Restart the serial audio clocks
- Wait for a delay of 1.0 ms (to allow the PLL to lock)
- Negate the power-down control signal (logic 0)
- Negate  $\overline{\text{RESET}}$  (logic 1)

The device then returns to the state it was in before power down (resumes normal operation).

#### 7.3.1 Power-Down Timing Sequence

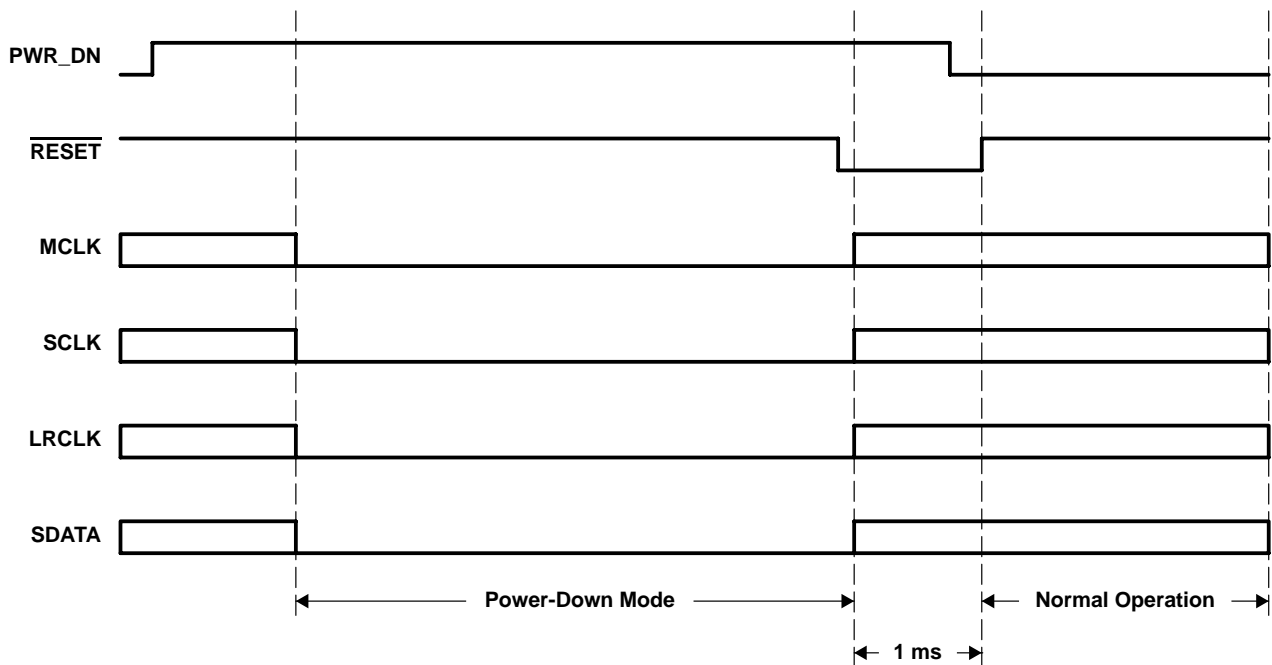

**Figure 7–2. Power-Down Timing Sequence**

In power-down mode, the TAS3004 device consumes typically less than 1 mA.

## 7.4 Test Mode

Terminal 9 (TEST) is tied low in normal operation. This function is reserved for factory test and must not be asserted.

## 7.5 Internal Interface

Figure 7–3 shows the block diagram of the interface between the microcontroller and its peripheral blocks.

## 7.6 GPI Terminal Programming

During initialization, the microcontroller fetches a control byte from its EPROM or receives a command from I<sup>2</sup>C.

### 7.6.1 Switch Interface

The six GPI terminals are programmed to operate in the following manner:

**Table 7–1. GPI Terminal Programming**

	GPI5	GPI4	GPI3	GPI2	GPI1	GPI0
VOL_UP, +1 dB	x					
VOL_DN, -1 dB		x				
BASS_UP, +1 dB			x			
BASS_DN, -1 dB				x		
TREB_UP, +1 dB					x	
TREB_DN, -1 dB						x
Shift 1	x					x
Mute	x					
EQ1		x				
EQ2			x			
EQ3				x		
EQ4					x	
EQ5						x
Shift 2			x	x		

NOTE: x = Logic low

Initially (after reset), the TAS3004 GPI is set to control volume, bass, and treble. Simultaneously setting GPI bits 1 and 5 low for 1 second changes the function of the GPI terminals to control mute and equalization.

To return to volume, bass, and treble control, simultaneously set GPI terminals 2 and 3 low for 1 second.

When a GPI switch is activated, the TAS3004 device echoes its function over I<sup>2</sup>C to a TAS3001 device mapped to address x6Ah. Therefore, a system with two audio equalization chips can be implemented without the need for a microcontroller.

### 7.6.2 GPI Architecture

The GPI provides simple but flexible input port to activate the input parameters. Each terminal input is an active logic low.

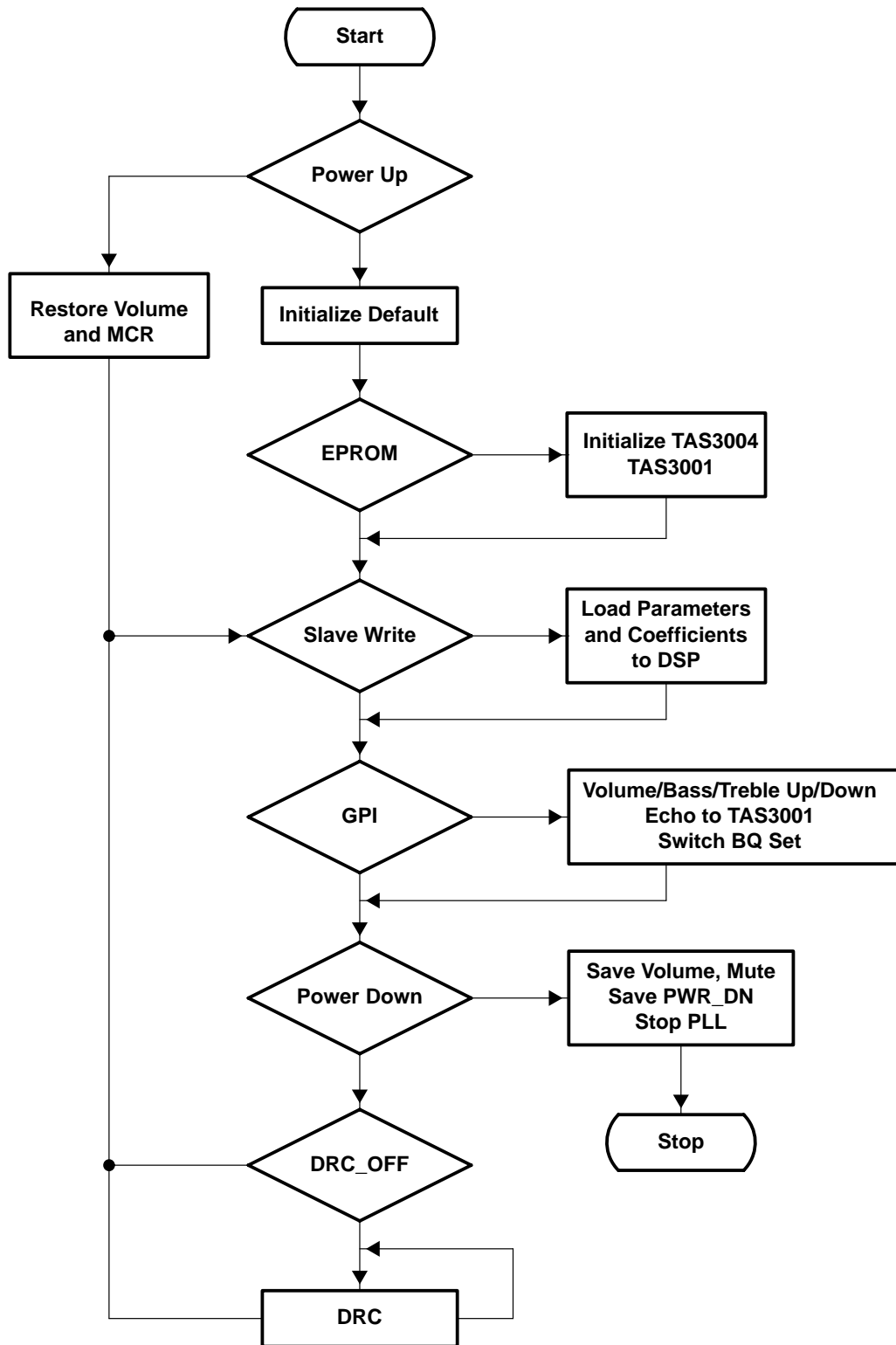

Figure 7-3. Internal Interface Block Diagram

## 7.7 External EPROM Memory Maps

Table 7–2 through Table 7–5 show the 512-byte and 2048-byte EPROM memory maps.

**Table 7–2. 512-Byte EPROM Memory Map 2.0 Channels**

ADDRESS	BYTE NUMBER	FUNCTION	
000h	1	Signature (2Ah)	
001h	1	ID byte = 0000 0000	
002h	1	MCR	
003h–00Bh	9	Mixer left gain	
00Ch–014h	9	Mixer right gain	
015h–01Ah	6	DRC (ratio, threshold, energy $\alpha$ , attack $\alpha$ , decay $\alpha$ )	
01Bh	1	Bass	
01Ch	1	Treble	
01Dh–022h	6	Volume	
031h–03Fh	15	Biquad 0	Left channel
040h–04Eh	15	Biquad 1	
04Fh–05Dh	15	Biquad 2	
05Eh–06Ch	15	Biquad 3	
06Dh–07Bh	15	Biquad 4	
07Ch–08Ah	15	Biquad 5	
08Bh–099h	15	Biquad 6	
09Ah	1	0 dB/bass	Right channel
09Bh	1	0 dB/treble	
09Ch–0A1h	6	Bass break	
0A2h–0A7h	6	Treble break	
0A8h–110h	105	Bass delta	
111h–179h	105	Treble delta	
17Ah–17Fh	6	Bass set point	
180h–185h	6	Treble set point	
186h–194h	15	Biquad 0	
195h–1A3h	15	Biquad 1	
1A4h–1B2h	15	Biquad 2	
1B3h–1C1h	15	Biquad 3	
1C2h–1D0h	15	Biquad 4	
1D1h–1DFh	15	Biquad 5	
1E0h–1EEh	15	Biquad 6	

NOTE: Bytes are in the same order as they appear in the I<sup>2</sup>C register map. The EPROM address is xA0h.

**Table 7–3. 512-Byte EPROM Memory Map 2.1 Channels (with TAS3001)**

ADDRESS	BYTE NUMBER		FUNCTION	
000h	1		Signature (2Ah)	
001h	1		ID byte = 0000 0011	
	TAS3004	AD81	TAS3004	TAS3001
002h	1	1	MCR	1EFh
003h–00Bh	9	9	Mixer left gain	1F0h–1F2h
00Ch–014h	9	9	Mixer right gain	1F3h–1F5h
015h–01Ah	6	6	DRC (ratio, threshold, energy $\alpha$ , attack $\alpha$ , decay $\alpha$ )	1F6h–1F7h
01Bh	1	1	Bass	1F8h
01Ch	1	1	Treble	1F9h
01Dh–022h	6	6	Volume	1FAh–1FFh
031h–03Fh	15		Biquad 0	TAS3004 right and left channel
040h–04Eh	15		Biquad 1	
04Fh–05Dh	15		Biquad 2	
05Eh–06Ch	15		Biquad 3	
06Dh–07Bh	15		Biquad 4	
07Ch–08Ah	15		Biquad 5	
08Bh–099h	15		Biquad 6	
09Ah	1		0 dB/bass	
09Bh	1		0 dB/treble	
09Ch–0A1h	6		Bass break	
0A2h–0A7h	6		Treble break	
0A8h–110h	105		Bass delta	
111h–179h	105		Treble delta	
17Ah–17Fh	6		Bass set point	
180h–185h	6		Treble set point	
186h–194h	15		Biquad 0	TAS3001 right and left channel
195h–1A3h	15		Biquad 1	
1A4h–1B2h	15		Biquad 2	
1B3h–1C1h	15		Biquad 3	
1C2h–1D0h	15		Biquad 4	
1D1h–1DFh	15		Biquad 5	
1E0h–1EEh	15		Biquad 6	

NOTE: In this mode, the TAS3004 and the TAS3001 devices both use the same equalization coefficients for their right and left channels. Bytes are in the same order as they appear in the I<sup>2</sup>C register map. The EPROM address is xA0h.

**Table 7–4. 2048-Byte EPROM Memory Map—2.0 Speakers With Multiple Equalizations**

TAS3004 ADDRESS LEFT BIQUAD	NUMBER OF BYTES	FUNCTION	CATEGORY	TAS3004 ADDRESS RIGHT BIQUAD	TAS3001				
000h	1	Signature (2Ah)							
001h	1	1	0	0	0	0	0	1	0
002h	1	MCR				1EFh			
003h–00Bh	9/3	Mixer left gain				1F0h–1F2h			
00Ch–014h	9/3	Mixer right gain				1F3h–1F5h			
015h–019h	5/2	DRC (ratio, threshold, energy $\alpha$ , attack $\alpha$ , decay $\alpha$ )				1F6h–1F7h			
01Ah	1	Bass				1F8h			
01Bh	1	Treble				1F9h			
01Ch–021h	6	Volume				1FAh–1FFh			
031h–03Fh	15	Biquad 0	Set 0	3A4h–3B2h	186h–194h				
040h–04Eh	15	Biquad 1		3B3h–3C1h	195h–1A3h				
04Fh–05Dh	15	Biquad 2		3C2h–3D0h	1A4h–1B2h				
05Eh–06Ch	15	Biquad 3		3D1h–3DFh	1B3h–1C1h				
06Dh–07Bh	15	Biquad 4		3E0h–3EEh	1C2h–1D0h				
07Ch–08Ah	15	Biquad 5		3EFh–3FDh	1D1h–1DFh				
08Bh–099h	15	Biquad 6		3FEh–40Ch	1E0h–1EEh				
09Ah–185h	236	Bass treble table							
200h–20Eh	15	Biquad 0	Set 1	40Dh–41Bh	5B1h–5BFh				
20Fh–21Dh	15	Biquad 1		41Ch–42Ah	5C0h–5CEh				
21Eh–22Ch	15	Biquad 2		42Bh–439h	5CFh–5DDh				
22Dh–23Bh	15	Biquad 3		43Ah–448h	5DEh–5ECh				
23Ch–24Ah	15	Biquad 4		449h–457h	5EDh–5FBh				
24Bh–259h	15	Biquad 5		458h–466h	5FCh–60Ah				
25Ah–268h	15	Biquad 6		467h–475h	60Bh–619h				
269h–277h	15	Biquad 0	Set 2	476h–484h	61Ah–628h				
278h–286h	15	Biquad 1		485h–493h	629h–637h				
287h–295h	15	Biquad 2		494h–4A2h	638h–646h				
296h–2A4h	15	Biquad 3		4A3h–4B1h	647h–655h				
2A5h–2B3h	15	Biquad 4		4B2h–4C0h	656h–664h				
2B4h–2C2h	15	Biquad 5		4C1h–4CFh	665h–673h				
2C3h–2D1h	15	Biquad 6		4D0h–4DEh	674h–682h				
2D2h–2E0h	15	Biquad 0	Set 3	4DFh–4EDh	683h–691h				
2E1h–2EFh	15	Biquad 1		4EEh–4FCh	692h–6A0h				
2F0h–2FEh	15	Biquad 2		4FDh–50Bh	6A1h–6AFh				
2FFh–30Dh	15	Biquad 3		50Ch–51Ah	6B0h–6BEh				
30Eh–31Ch	15	Biquad 4		51Bh–529h	6BFh–6CDh				
31Dh–32Bh	15	Biquad 5		52Ah–538h	6CEh–6DCh				
32Ch–33Ah	15	Biquad 6		539h–547h	6DDh–6EBh				
33Bh–349h	15	Biquad 0	Set 4	548h–556h	6ECh–6FAh				
34Ah–358h	15	Biquad 1		557h–565h	6FBh–709h				
359h–367h	15	Biquad 2		566h–574h	70Ah–718h				
368h–376h	15	Biquad 3		575h–583h	719h–727h				
377h–385h	15	Biquad 4		584h–592h	728h–736h				
386h–394h	15	Biquad 5		593h–5A1h	737h–745h				
395h–3A3h	15	Biquad 6		5A2h–5B0h	746h–754h				

NOTE: Bytes are in the same order as they appear in the I<sup>2</sup>C register map. The EPROM address is xA0h.

**Table 7–5. 2048-Byte EPROM Memory Map—2.1 Speakers With Multiple Equalizations**

TAS3004 ADDRESS	NUMBER OF BYTES	FUNCTION	CATEGORY	TAS3001 ADDRESS LEFT CHANNEL	TAS3001 ADDRESS RIGHT CHANNEL
000h	1	Signature (2Ah)			
001h	1	1	0	0	0
002h	1	MCR			1EFh
003h–00Bh	9/3	Mixer left gain			1F0h–1F2h
00Ch–014h	9/3	Mixer right gain			1F3h–1F5h
015h–019h	5/2	DRC (ratio, threshold, energy $\alpha$ , attack $\alpha$ , decay $\alpha$ )			1F6h–1F7h
01Ah	1	Bass			1F8h
01Bh	1	Treble			1F9h
01Ch–021h	6	Volume			1FAh–1FFh
031h–03Fh	15	Biquad 0	Set 0	186h–194h	3A4h–3B2h
040h–04Eh	15	Biquad 1		195h–1A3h	3B3h–3C1h
04Fh–05Dh	15	Biquad 2		1A4h–1B2h	3C2h–3D0h
05Eh–06Ch	15	Biquad 3		1B3h–1C1h	3D1h–3DFh
06Dh–07Bh	15	Biquad 4		1C2h–1D0h	3E0h–3EEh
07Ch–08Ah	15	Biquad 5		1D1h–1DFh	3EFh–3FDh
08Bh–099h	15	Biquad 6		1E0h–1EEh	3FEh–40Ch
09Ah–185h	236	Bass treble table			
200h–20Eh	15	Biquad 0	Set 1	5B1h–5BFh	40Dh–41Bh
20Fh–21Dh	15	Biquad 1		5C0h–5CEh	41Ch–42Ah
21Eh–22Ch	15	Biquad 2		5CFh–5DDh	42Bh–439h
22Dh–23Bh	15	Biquad 3		5DEh–5ECh	43Ah–448h
23Ch–24Ah	15	Biquad 4		5EDh–5FBh	449h–457h
24Bh–259h	15	Biquad 5		5FCh–60Ah	458h–466h
25Ah–268h	15	Biquad 6		60Bh–619h	467h–475h
269h–277h	15	Biquad 0	Set 2	61Ah–628h	476h–484h
278h–286h	15	Biquad 1		629h–637h	485h–493h
287h–295h	15	Biquad 2		638h–646h	494h–4A2h
296h–2A4h	15	Biquad 3		647h–655h	4A3h–4B1h
2A5h–2B3h	15	Biquad 4		656h–664h	4B2h–4C0h
2B4h–2C2h	15	Biquad 5		665h–673h	4C1h–4CFh
2C3h–2D1h	15	Biquad 6		674h–682h	4D0h–4DEh
2D2h–2E0h	15	Biquad 0	Set 3	683h–691h	4DFh–4EDh
2E1h–2EFh	15	Biquad 1		692h–6A0h	4EEh–4FCh
2F0h–2FEh	15	Biquad 2		6A1h–6AFh	4FDh–50Bh
2FFh–30Dh	15	Biquad 3		6B0h–6BEh	50Ch–51Ah
30Eh–31Ch	15	Biquad 4		6BFh–6CDh	51Bh–529h
31Dh–32Bh	15	Biquad 5		6CEh–6DCh	52Ah–538h
32Ch–33Ah	15	Biquad 6		6DDh–6EBh	539h–547h
33Bh–349h	15	Biquad 0	Set 4	6ECh–6FAh	548h–556h
34Ah–358h	15	Biquad 1		6FBh–709h	557h–565h
359h–367h	15	Biquad 2		70Ah–718h	566h–574h
368h–376h	15	Biquad 3		719h–727h	575h–583h
377h–385h	15	Biquad 4		728h–736h	584h–592h
386h–394h	15	Biquad 5		737h–745h	593h–5A1h
395h–3A3h	15	Biquad 6		746h–754h	5A2h–5B0h

NOTE: Bytes are in the same order as they appear in the I<sup>2</sup>C register map. The EPROM address is xA0h.



## 8 Electrical Characteristics

### 8.1 Absolute Maximum Ratings Over Operating Temperature Ranges†

Supply voltage range: $AV_{DD\_PLL}$ .....	-0.3 V to 3.6 V
$DV_{DD}$ .....	-0.3 V to 3.6 V
Digital input voltage range: .....	-0.3 to $V_{DD} + 0.3$ V
Operating free-air temperature, $T_A$ .....	0°C to 70°C
Storage temperature range, $T_{stg}$ .....	-65°C to 150°C
Case temperature for 10 seconds .....	+122°C
Lead temperature from case for 10 seconds .....	+97.8°C
Electrostatic discharge (see Note 1) .....	2000 V

† Stresses beyond those listed under absolute maximum ratings may cause permanent damage to the device. These are stress ratings only, and functional operation of the device at these or any other conditions beyond those indicated under recommended operating conditions is not implied. Exposure to absolute-maximum-rated conditions for extended periods may affect device reliability.

NOTE 1: Human body model per Method 3015.2 of MIL-STD-883B.

### 8.2 Recommended Operating Conditions

$T_A = 25^\circ\text{C}$ ,  $AV_{DD} = 3.3$  V,  $DV_{DD} = 3.3$  V

Voltages at analog inputs and outputs and at  $AV_{DD}$  are with respect to ground.

		MIN	NOM	MAX	UNIT
Supply voltage, $AV_{DD}$		3.0	3.3	3.6	V
Supply voltage, $DV_{DD}$		3.0	3.3	3.6	V
Supply current, analog	Operating	34			mA
	Power down (see Note 2)	88			$\mu\text{A}$
Supply current, digital	Operating	47			mA
	Power down (see Note 2)	942			$\mu\text{A}$
Power dissipation	Operating	267			mW
	Power down (see Note 2)	0.35			W

NOTE 2: If the clocks are turned off.

### 8.3 Static Digital Specifications

$T_A = 25^\circ\text{C}$ ,  $AV_{DD} = 3.3$  V,  $DV_{DD} = 3.3$  V

PARAMETER		TEST CONDITIONS	MIN	MAX	UNIT
$V_{IH}$	High-level input voltage		2.0	3.6	V
$V_{IL}$	Low-level output voltage		-0.3	0.8	V
$V_{OH}$	High-level output voltage	$I_O = -1$ mA	2.4		V
$V_{OL}$	Low-level output voltage	$I_O = +4$ mA		0.4	V
Input leakage current			-10	10	$\mu\text{A}$
Output load capacitance				50	pF

## 8.4 ADC Digital Filter

$T_A = 25^\circ\text{C}$ ,  $AV_{DD} = 3.3\text{ V}$ ,  $DV_{DD} = 3.3\text{ V}$ ,  $f_S = 48\text{ kHz}$ , 20-bit I<sup>2</sup>S mode

All terms characterized by frequency are scaled with the chosen sampling frequency,  $f_S$ . See Figure 8–1 through Figure 8–4 for performance curves of the ADC digital filter.

PARAMETER	TEST CONDITIONS	MIN	TYP	MAX	UNIT
ADC decimation filter (LPF)					
Pass band		0.0		20.0	kHz
Pass band ripple			$\pm 0.01$		dB
Stop band			24.1		kHz
Stop band attenuation		80			dB
Group delay			720		$\mu\text{s}$
ADC high-pass filter (HPF)					
Pass band ( $-3\text{ dB}$ )			0.87		Hz
Deviation from linear phase	20 Hz to 20 kHz		1.23		degrees

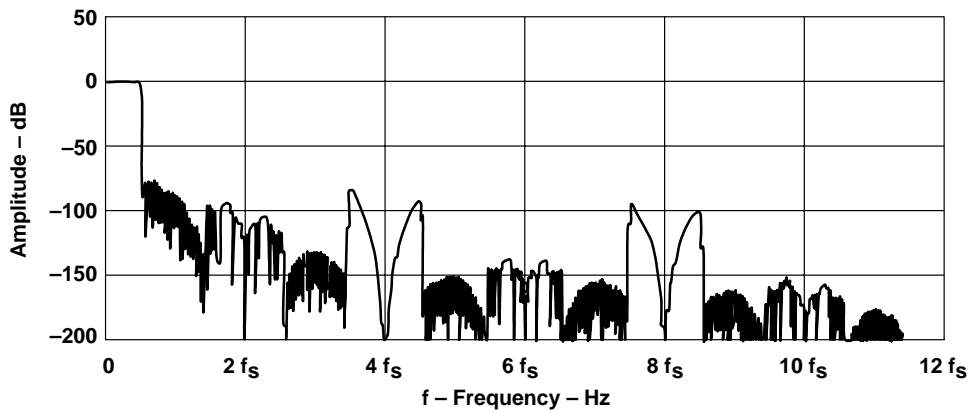

Figure 8–1. ADC Digital Filter Characteristics

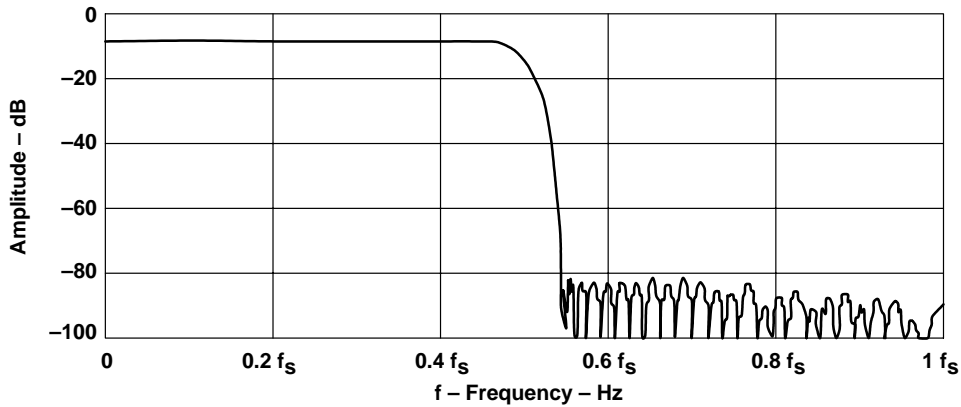

Figure 8–2. ADC Digital Filter Stopband Characteristics

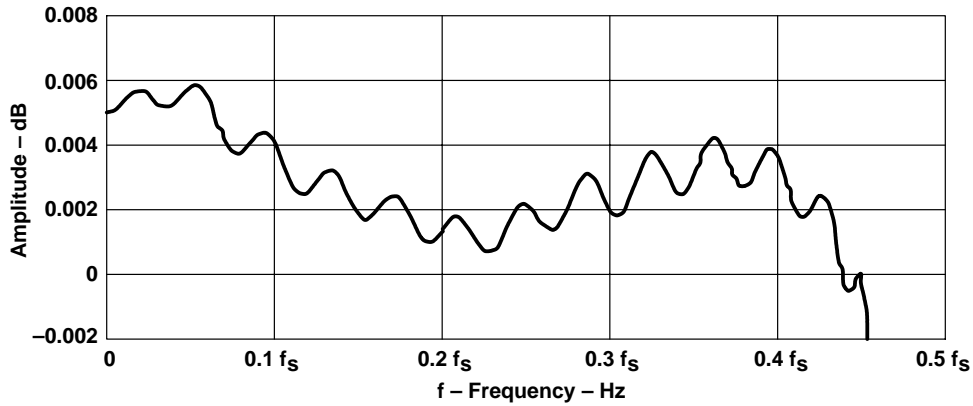

Figure 8-3. ADC Digital Filter Passband Characteristics

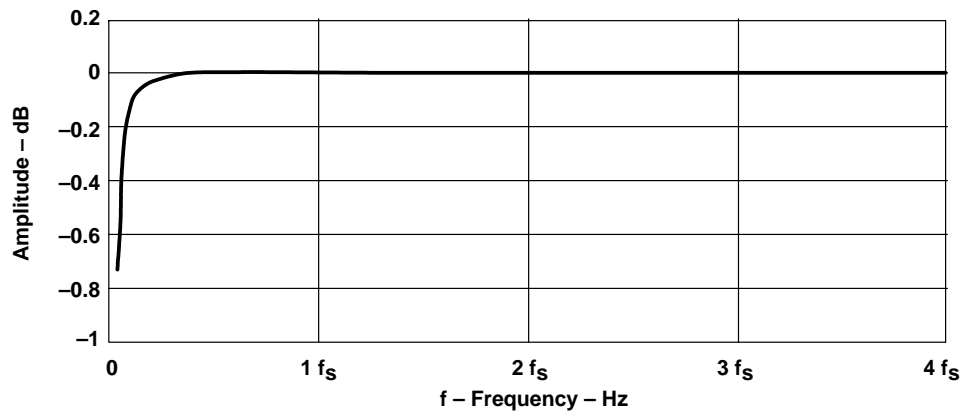

Figure 8-4. ADC High Pass Filter Characteristics

## 8.5 Analog-to-Digital Converter

$T_A = 25^\circ\text{C}$ ,  $AV_{DD} = 3.3\text{ V}$ ,  $DV_{DD} = 3.3\text{ V}$ ,  $f_S = 48\text{ kHz}$ , 20-bit I<sup>2</sup>S mode

All terms characterized by frequency are scaled with the chosen sampling frequency,  $f_S$ .

PARAMETER	TEST CONDITIONS	MIN	TYP	MAX	UNIT
SNR (EIAJ)	A weighted		93		dB
Dynamic range	-60 dB, 1 kHz		88		dB
Signal to (noise + distortion) ratio	-1 dB, 1 kHz, 20 Hz to 20 kHz		82		dB
Power supply rejection ratio	1 kHz (see Note 3)		50		dB
Idle channel tone rejection			+110		dB
Intermodulation distortion			-80		dB
ADC crosstalk			93		dB
Overall ADC frequency response	20 Hz to 20 kHz		$\pm 0.1$		dB
Gain error				5%	
Gain matching			$\pm 0.02$		dB

NOTE 3: Measured with a 50-mV peak sine curve.

## 8.6 Input Multiplexer

$T_A = 25^\circ\text{C}$ ,  $AV_{DD} = 3.3\text{ V}$ ,  $DV_{DD} = 3.3\text{ V}$ ,  $f_S = 48\text{ kHz}$ , 20-bit I<sup>2</sup>S mode

All terms characterized by frequency are scaled with the chosen sampling frequency,  $f_S$ .

PARAMETER	TEST CONDITIONS	MIN	TYP	MAX	UNIT
Input impedance			20		k $\Omega$
Crosstalk			85		dB
Full scale input voltage range			1.7		V <sub>PP</sub>

## 8.7 DAC Interpolation Filter

$T_A = 25^\circ\text{C}$ ,  $AV_{DD} = 3.3\text{ V}$ ,  $DV_{DD} = 3.3\text{ V}$ ,  $f_S = 48\text{ kHz}$ , 20-bit I<sup>2</sup>S mode

All terms characterized by frequency are scaled with the normal mode sampling frequency,  $f_S$ . See Figure 8–5 and Figure 8–6 for performance curves of the DAC digital filter.

PARAMETER	TEST CONDITIONS	MIN	TYP	MAX	UNIT
Pass band		0.0		20.0	kHz
Pass band ripple			$\pm 0.005$		dB
Stop band			24.1		kHz
Stop band attenuation	28.8 kHz to 3 MHz	75			dB
Group delay			700		$\mu\text{s}$

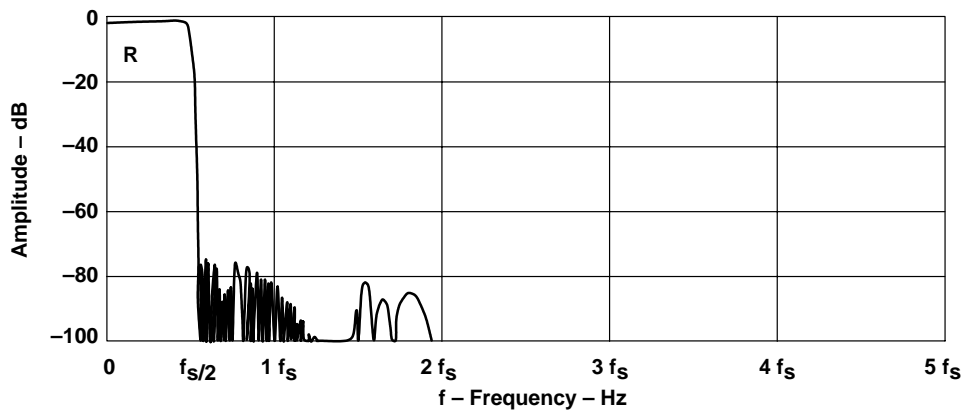

Figure 8–5. DAC Filter Overall Frequency Characteristics

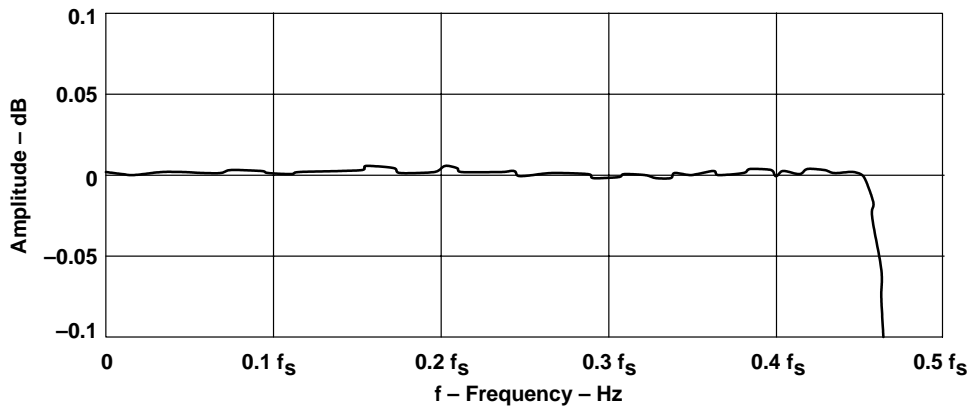

Figure 8–6. DAC Digital Filter Passband Ripple Characteristics

## 8.8 Digital-to-Analog Converter

$T_A = 25^\circ\text{C}$ ,  $AV_{DD} = 3.3\text{ V}$ ,  $DV_{DD} = 3.3\text{ V}$ ,  $f_S = 48\text{ kHz}$ , input = 0 dB- $f_S$  sine wave at 1 kHz  
 All terms characterized by frequency are scaled with the chosen sampling frequency,  $f_S$ .

PARAMETER	TEST CONDITIONS	MIN	TYP	MAX	UNIT
SNR (EIAJ)	A weighted	94	99		dB
Dynamic range	-60 dB, 1 kHz	92	96		dB
Signal to (noise + distortion) ratio	0 dB, 1 kHz, 20 Hz to 20 kHz		83		dB
Power supply rejection ratio	1 kHz		50		dB
Idle channel tone rejection			+118		dB
Intermodulation distortion			-75		dB
Frequency response		-0.5		+0.5	dB
Deviation from linear phase				$\pm 1.4$	degree
DAC crosstalk			-96		dB
Jitter tolerance			150		ps
Full scale, single-ended, output voltage range			1.9		$V_{PP}$
DC offset		-7.0		7.0	mV

## 8.9 DAC Output Performance Data

$T_A = 25^\circ\text{C}$ ,  $AV_{DD} = 3.3\text{ V}$ ,  $DV_{DD} = 3.3\text{ V}$

The output load resistance is connected through a dc blocking capacitor.

PARAMETER	TEST CONDITIONS	MIN	TYP	MAX	UNIT
Output load resistance		10			$k\Omega$
Output load capacitance				25	pF
VCOM internal resistance (see Note 4)			1		$k\Omega$
VCOM output CLOAD			10	100	$\mu\text{F}$
VRFILF internal resistance (see Note 5)			1		$k\Omega$

NOTES: 4. VCOM may vary during power down.  
 5. VRFILF must never be used as a voltage reference.

## 8.10 I<sup>2</sup>C Serial Port Timing Characteristics

		MIN	MAX	UNIT
$f_{scl}$	SCL clock frequency	0	100	kHz
$t_{buf}$	Bus free time between start and stop	4.7		$\mu$ s
$t_{low}$	Low period of SCL clock	4.7		$\mu$ s
$t_{high}$	High period of SCL clock	4.0		$\mu$ s
$t_{hdsta}$	Hold time repeated start	4.0		$\mu$ s
$t_{susta}$	Setup time repeated start	4.7	20	$\mu$ s
$t_{hd dat}$	Data hold time (See Note 6)	0		$\mu$ s
$t_{sudat}$	Data setup time	250		ns
$t_r$	Rise time for SDA and SCL		1000	ns
$t_f$	Fall time for SDA and SCL		300	ns
$t_{susto}$	Setup time for stop condition	4.0		$\mu$ s
$C_b$	Capacitive load for each bus line		400	pF

NOTE 6: A device must internally provide a hold time of at least 300 ns for the SDA signal to bridge the undefined region of the falling edge of SCL.

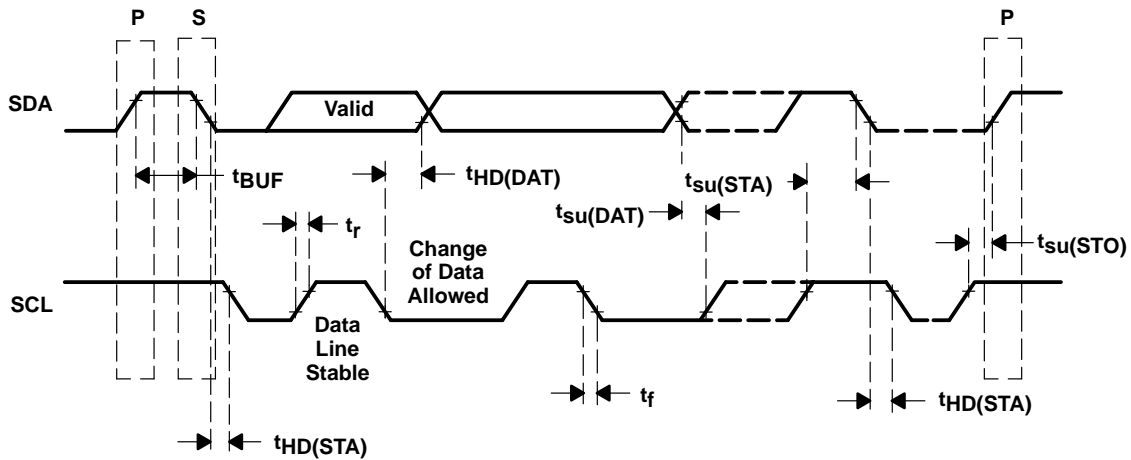

NOTE:  $t_{low}$  is measured from the end of  $t_f$  to the beginning of  $t_r$ .  
 $t_{high}$  is measured from the end of  $t_r$  to the beginning of  $t_f$ .

Figure 8–7. I<sup>2</sup>C Bus Timing

## 9 System Diagrams

Figure 9–1 and Figure 9–2 show the TAS3004 stereo and 2.1-channel applications, respectively.

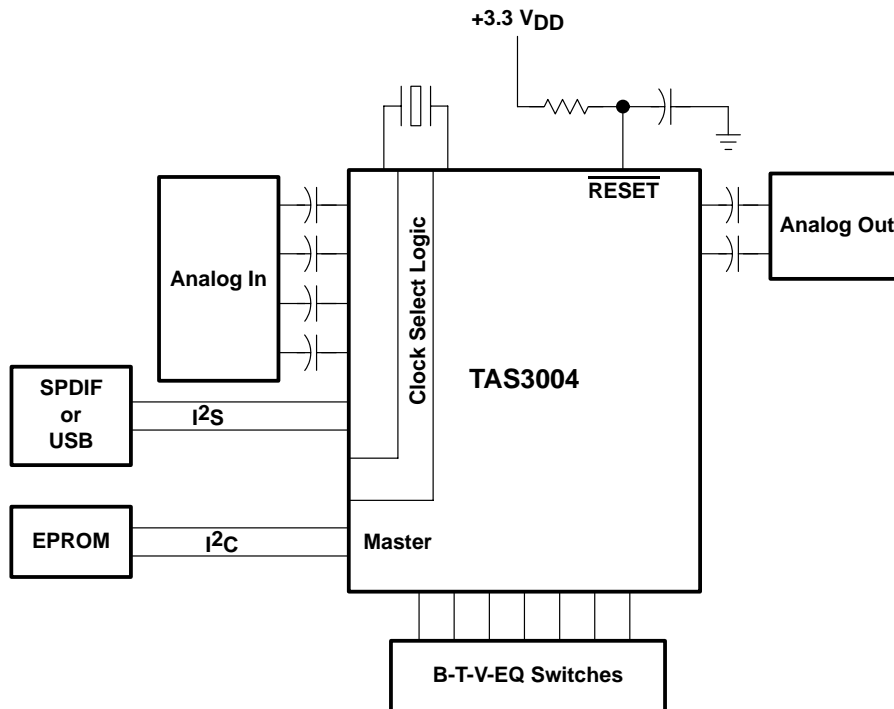

NOTE: Items such as the PLL network and power supplies are omitted for clarity.

**Figure 9–1. Stereo Application**

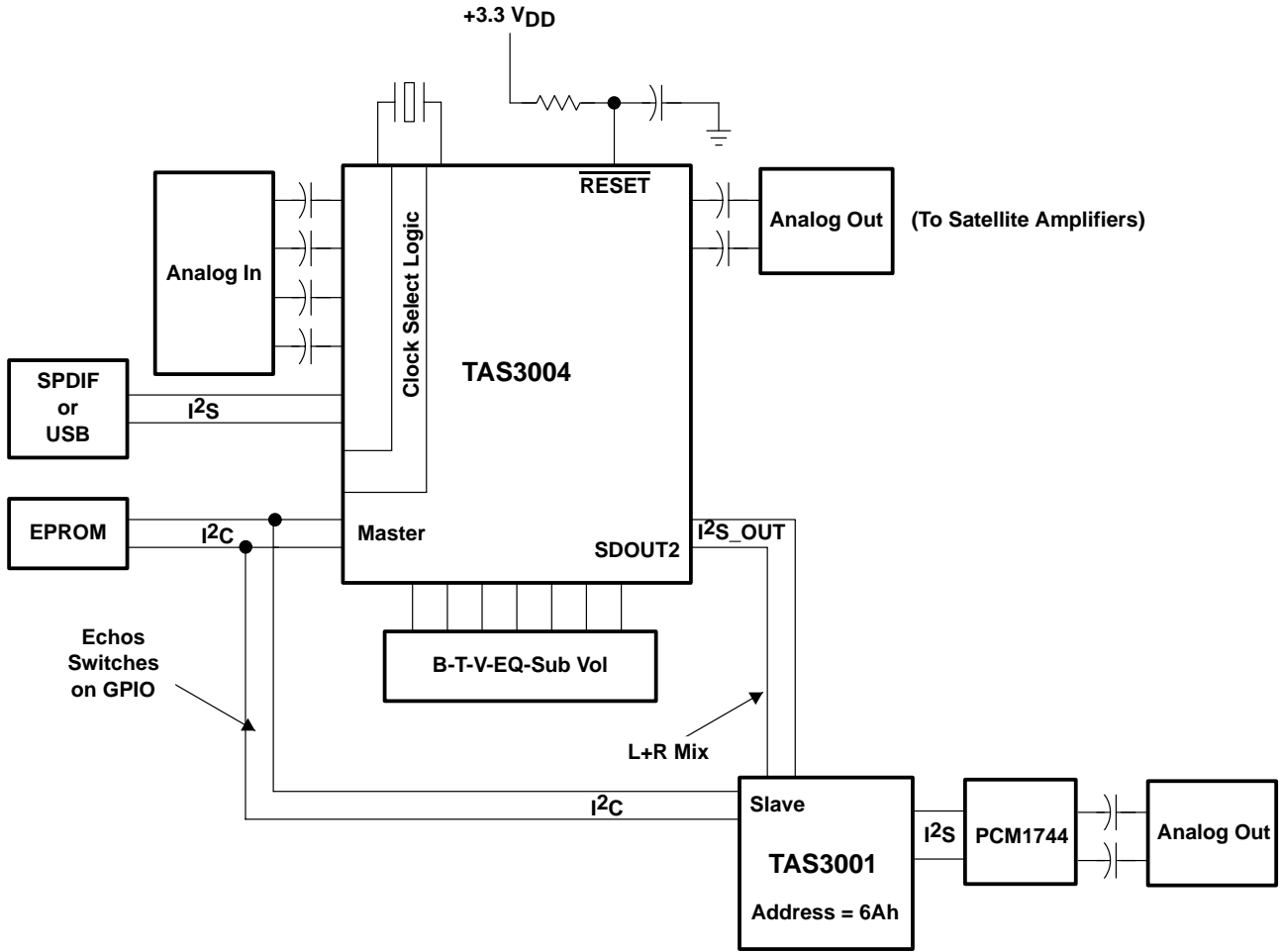

NOTE: Items such as the PLL network and power supplies are omitted for clarity.

**Figure 9–2. TAS3004 Device, 2.1 Channels**

## 10 Mechanical Information

The TAS3004 device is packaged in a 48-terminal PFB package. The following illustration shows the mechanical dimensions for the PFB package.

PFB (S-PQFP-G48)

PLASTIC QUAD FLATPACK

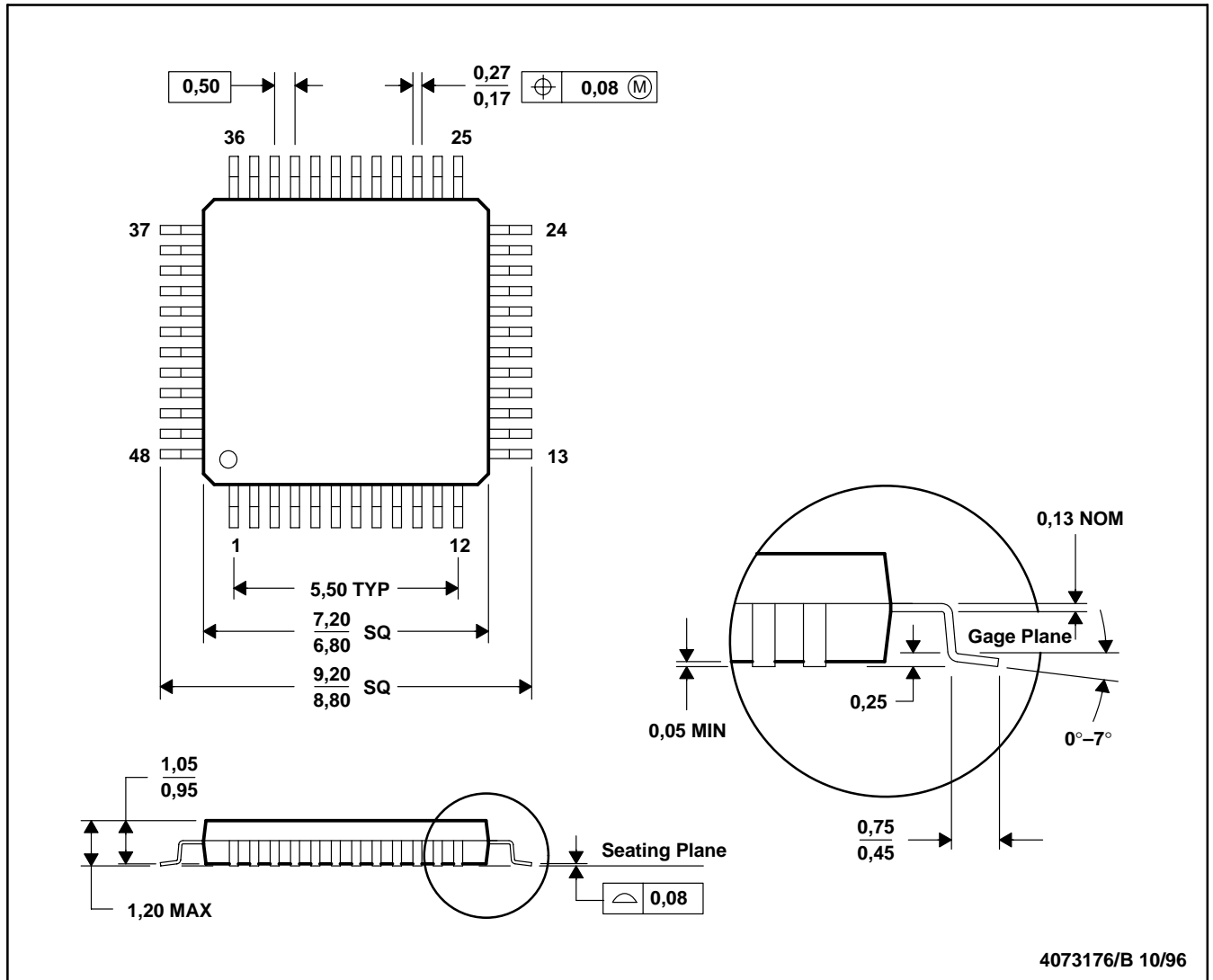



## Appendix A Software Interface

**Table A-1. I<sup>2</sup>C Register Map**

REGISTER	ADDRESS	NUMBER OF BYTES	BYTE DESCRIPTION
Reserved	0x00		
Main control	0x01	1	C(7-0)
DRC	0x02	5	Ratio(7-0), Threshold(7-0), Energy(7-0), Attack(7-0), Decay(7-0)
Reserved	0x03		
Volume	0x04	6	VL(23-16), VL(15-8), VL(7-0) VR(23-16), VR(15-8), VR(7-0)
Treble	0x05	1	T(7-0)
Bass	0x06	1	B(7-0)
Mixer left gain	0x07	9	S1L(23-16), S1L(15-8), S1L(7-0) S2L(23-16), S2L(15-8), S2L(7-0) AIL(23-16), AIL(15-8), AIL(7-0)
Mixer right gain	0x08	9	S1R(23-16), S1R(15-8), S1R(7-0) S2R(23-16), S2R(15-8), S2R(7-0) AIR(23-16), AIR(15-8), AIR(7-0)
Reserved	0x09		
Left biquad 0	0x0A	15	B0(23-16), B0(15-8), B0(7-0) B1(23-16), B1(15-8), B1(7-0) B2(23-16), B2(15-8), B2(7-0) A1(23-16), A1(15-8), A1(7-0) A2(23-16), A2(15-8), A2(7-0)
Left biquad 1	0x0B	15	B0(23-16), B0(15-8), B0(7-0) B1(23-16), B1(15-8), B1(7-0) B2(23-16), B2(15-8), B2(7-0) A1(23-16), A1(15-8), A1(7-0) A2(23-16), A2(15-8), A2(7-0)
Left biquad 2	0x0C	15	B0(23-16), B0(15-8), B0(7-0) B1(23-16), B1(15-8), B1(7-0) B2(23-16), B2(15-8), B2(7-0) A1(23-16), A1(15-8), A1(7-0) A2(23-16), A2(15-8), A2(7-0)
Left biquad 3	0x0D	15	B0(23-16), B0(15-8), B0(7-0) B1(23-16), B1(15-8), B1(7-0) B2(23-16), B2(15-8), B2(7-0) A1(23-16), A1(15-8), A1(7-0) A2(23-16), A2(15-8), A2(7-0)
Left biquad 4	0x0E	15	B0(23-16), B0(15-8), B0(7-0) B1(23-16), B1(15-8), B1(7-0) B2(23-16), B2(15-8), B2(7-0) A1(23-16), A1(15-8), A1(7-0) A2(23-16), A2(15-8), A2(7-0)
Left biquad 5	0x0F	15	B0(23-16), B0(15-8), B0(7-0) B1(23-16), B1(15-8), B1(7-0) B2(23-16), B2(15-8), B2(7-0) A1(23-16), A1(15-8), A1(7-0) A2(23-16), A2(15-8), A2(7-0)

**Table A-1. I<sup>2</sup>C Register Map (Continued)**

REGISTER	ADDRESS	NUMBER OF BYTES	BYTE DESCRIPTION
Left biquad 6	0x10	15	B0(23-16), B0(15-8), B0(7-0) B1(23-16), B1(15-8), B1(7-0) B2(23-16), B2(15-8), B2(7-0) A1(23-16), A1(15-8), A1(7-0) A2(23-16), A2(15-8), A2(7-0)
Reserved	0x11		
Reserved	0x12		
Right biquad 0	0x13	15	B0(23-16), B0(15-8), B0(7-0) B1(23-16), B1(15-8), B1(7-0) B2(23-16), B2(15-8), B2(7-0) A1(23-16), A1(15-8), A1(7-0) A2(23-16), A2(15-8), A2(7-0)
Right biquad 1	0x14	15	B0(23-16), B0(15-8), B0(7-0) B1(23-16), B1(15-8), B1(7-0) B2(23-16), B2(15-8), B2(7-0) A1(23-16), A1(15-8), A1(7-0) A2(23-16), A2(15-8), A2(7-0)
Right biquad 2	0x15	15	B0(23-16), B0(15-8), B0(7-0) B1(23-16), B1(15-8), B1(7-0) B2(23-16), B2(15-8), B2(7-0) A1(23-16), A1(15-8), A1(7-0) A2(23-16), A2(15-8), A2(7-0)
Right biquad 3	0x16	15	B0(23-16), B0(15-8), B0(7-0) B1(23-16), B1(15-8), B1(7-0) B2(23-16), B2(15-8), B2(7-0) A1(23-16), A1(15-8), A1(7-0) A2(23-16), A2(15-8), A2(7-0)
Right biquad 4	0x17	15	B0(23-16), B0(15-8), B0(7-0) B1(23-16), B1(15-8), B1(7-0) B2(23-16), B2(15-8), B2(7-0) A1(23-16), A1(15-8), A1(7-0) A2(23-16), A2(15-8), A2(7-0)
Right biquad 5	0x18	15	B0(23-16), B0(15-8), B0(7-0) B1(23-16), B1(15-8), B1(7-0) B2(23-16), B2(15-8), B2(7-0) A1(23-16), A1(15-8), A1(7-0) A2(23-16), A2(15-8), A2(7-0)
Right biquad 6	0x19	15	B0(23-16), B0(15-8), B0(7-0) B1(23-16), B1(15-8), B1(7-0) B2(23-16), B2(15-8), B2(7-0) A1(23-16), A1(15-8), A1(7-0) A2(23-16), A2(15-8), A2(7-0)
Reserved	0x20		
Left loudness biquad	0x21	15	B0(23-16), B0(15-8), B0(7-0) B1(23-16), B1(15-8), B1(7-0) B2(23-16), B2(15-8), B2(7-0) A1(23-16), A1(15-8), A1(7-0) A2(23-16), A2(15-8), A2(7-0)
Right loudness biquad	0x22	15	B0(23-16), B0(15-8), B0(7-0) B1(23-16), B1(15-8), B1(7-0) B2(23-16), B2(15-8), B2(7-0) A1(23-16), A1(15-8), A1(7-0) A2(23-16), A2(15-8), A2(7-0)

**Table A–1. I<sup>2</sup>C Register Map (Continued)**

REGISTER	ADDRESS	NUMBER OF BYTES	BYTE DESCRIPTION
Left loudness biquad gain	0x23	3	LBG(23–16), LBG(15–8), LBG(7–0)
Right loudness biquad gain	0x24	3	RBG(23–16), RBG(15–8), RBG(7–0)
Test	0x29	10	Reserved
Reserved	0x30 to 0xFF		
Analog control	0x40	1	Anal_ctrl(7–0)
Test	0x41	1	
Test	0x42	1	
Main control 2	0x43	1	MCR2(7–0)

## A.1 Main Control Register Map

### A.1.1 Main Control Register 1

MCR 0X01							
C(7)	C(6)	C(5)	C(4)	C(3)	C(2)	C(1)	C(0)
FL	SC	E1	E0	F1	F0	W1	W0
1	x	x	x	x	x	x	x

**Table A–2. Main Control Register 1 Description**

REGISTER	DESCRIPTOR	FUNCTION	VALUE	DESCRIPTION
C(7)	FL	Fast load	0	Normal operation mode
			1	Fast load mode
C(6)	SC	SCLK frequency	0	SCLK = 32f <sub>S</sub>
			1	SCLK = 64f <sub>S</sub>
C(5–4)	E(1–0)	Serial port mode	00	Left justified
			01	Right justified
			10	I <sup>2</sup> S
			11	Reserved
C(3)	XX		1	Reserved
C(2)			0	Download
C(1–0)	W(1–0)	Serial port word length	00	16-bit
			01	18-bit
			10	20-bit
			11	24-bit

### A.1.2 Main Control Register 2

MCR2 0X43							
C2(7)	C2(6)	C2(5)	C2(4)	C2(3)	C2(2)	C2(1)	C2(0)
DL	XX	XX	XX	XX	XX	AP	XX
1	0	0	0	0	0	1	0

**Table A–3. Main Control Register 2 Description**

REGISTER	DESCRIPTOR	FUNCTION	VALUE	DESCRIPTION
C2(7)	DL	Bass and treble load	0	Normal operation mode
			1	Downloaded values
C2(6)	XX	Reserved	0	
			1	
C2(5)	XX	Reserved	0	
			1	
C2(4)	XX	Reserved	0	
			1	
C2(3)	XX	Reserved	0	
			1	
C2(2)	XX	Reserved	0	
			1	
C2(1)	AP	Allpass mode	0	Normal operation
			1	Sets equalization filters to all pass
C2(0)	XX	Reserved	0	
			1	

### A.1.3 Analog Control Register

ANA 0X40							
A(7)	A(6)	A(5)	A(4)	A(3)	A(2)	A(1)	A(0)
ADM	LRB	XX	XX	DM1	DM0	INP	APD
0	0	0	0	1	1	1	1

**Table A–4. Analog Control Register Description**

REGISTER	DESCRIPTOR	FUNCTION	VALUE	DESCRIPTION
A(7)	ADM	ADC output mode	0	Normal operation
			1	B inputs are monaural
A(6)	LRB	Selects left or right B input for monaural output	0	B left input selected for monaural ADC output when bit 7 (ADM) is set to 1
			1	B right input selected for monaural ADC output when bit 7 (ADM) is set to 1
A(5)	XX	Reserved	0	
			1	
A(4)	XX	Reserved	0	
			1	
A(3–2)	DM(1–0)	De-emphasis control	00	De-emphasis off, normal operation
			01	De-emphasis for $f_S = 48$ kHz
			10	De-emphasis for $f_S = 44.1$ kHz
			11	Reserved
A(1)	INP	Analog input select	0	A inputs selected
			1	B inputs selected
A(0)	APD	Analog power down	1	Powers down analog section
			0	Normal operation

## A.2 Volume Gain Command

The gain error is less than 0.12 dB (exclusive mute).

Device ID	Subaddress	VL(23–16)	VL(15–8)	VL(7–0)	VR(23–16)	VR(15–8)	VR(7–0)
-----------	------------	-----------	----------	---------	-----------	----------	---------

For example, if left volume = 6 dB and right volume = –6 dB, then the command is:

68	04	01	FE	CA	00	80	4E
----	----	----	----	----	----	----	----

**Table A–5. Volume Versus Gain Values**

GAIN (dB)	VOLUME V(23–16), V(15–8), V(7–0)	GAIN (dB)	VOLUME V(23–16), V(15–8), V(7–0)	GAIN (dB)	VOLUME V(23–16), V(15–8), V(7–0)	GAIN (dB)	VOLUME V(23–16), V(15–8), V(7–0)	GAIN (dB)	VOLUME V(23–16), V(15–8), V(7–0)
18.0	07, F1, 7B	3.0	01, 69, 9C	–12.0	00, 40, 4E	–27.0	00, 0B, 6F	–42.0	00, 02, 09
17.5	07, 7F, BB	2.5	01, 55, 62	–12.5	00, 3C, B5	–27.5	00, 0A, CC	–42.5	00, 01, EB
17.0	07, 14, 57	2.0	01, 42, 49	–13.0	00, 39, 50	–28.0	00, 0A, 31	–43.0	00, 01, D0
16.5	06, AE, F6	1.5	01, 30, 42	–13.5	00, 36, 1B	–28.5	00, 09, 9F	–43.5	00, 01, B6
16.0	06, 4F, 40	1.0	01, 1F, 3D	–14.0	00, 33, 14	–29.0	00, 09, 15	–44.0	00, 01, 9E
15.5	05, F4, E5	0.5	01, 0F, 2B	–14.5	00, 30, 39	–29.5	00, 08, 93	–44.5	00, 01, 86
15.0	05, 9F, 98	0.0	01, 00, 00	–15.0	00, 2D, 86	–30.0	00, 08, 18	–45.0	00, 01, 71
14.5	05, 4F, 10	–0.5	00, F1, AE	–15.5	00, 2A, FA	–30.5	00, 07, A5	–45.5	00, 01, 5C
14.0	05, 03, 0A	–1.0	00, E4, 29	–16.0	00, 28, 93	–31.0	00, 07, 37	–46.0	00, 01, 48
13.5	04, BB, 44	–1.5	00, D7, 66	–16.5	00, 26, 4E	–31.5	00, 06, D0	–46.5	00, 01, 36
13.0	04, 77, 83	–2.0	00, CB, 59	–17.0	00, 24, 29	–32.0	00, 06, 6E	–47.0	00, 01, 25
12.5	04, 37, 8B	–2.5	00, BF, F9	–17.5	00, 22, 23	–32.5	00, 06, 12	–47.5	00, 01, 14
12.0	03, FB, 28	–3.0	00, B5, 3C	–18.0	00, 20, 3A	–33.0	00, 05, BB	–48.0	00, 01, 05
11.5	03, C2, 25	–3.5	00, AB, 19	–18.5	00, 1E, 6D	–33.5	00, 05, 69	–48.5	00, 00, F6
11.0	03, 8C, 53	–4.0	00, A1, 86	–19.0	00, 1C, B9	–34.0	00, 05, 1C	–49.0	00, 00, E9
10.5	03, 59, 83	–4.5	00, 98, 7D	–19.5	00, 1B, 1E	–34.5	00, 04, D2	–49.5	00, 00, DC
10.0	03, 29, 8B	–5.0	00, 8F, F6	–20.0	00, 19, 9A	–35.0	00, 04, 8D	–50.0	00, 00, CF
9.5	02, FC, 42	–5.5	00, 87, E8	–20.5	00, 18, 2B	–35.5	00, 04, 4C	–50.5	00, 00, C4
9.0	02, D1, 82	–6.0	00, 80, 4E	–21.0	00, 16, D1	–36.0	00, 04, 0F	–51.0	00, 00, B9
8.5	02, A9, 25	–6.5	00, 79, 20	–21.5	00, 15, 8A	–36.5	00, 03, D5	–51.5	00, 00, AE
8.0	02, 83, 0B	–7.0	00, 72, 5A	–22.0	00, 14, 56	–37.0	00, 03, 9E	–52.0	00, 00, A5
7.5	02, 5F, 12	–7.5	00, 6B, F4	–22.5	00, 13, 33	–37.5	00, 03, 6A	–52.5	00, 00, 9B
7.0	02, 3D, 1D	–8.0	00, 65, EA	–23.0	00, 12, 20	–38.0	00, 03, 39	–53.0	00, 00, 93
6.5	02, 1D, 0E	–8.5	00, 60, 37	–23.5	00, 11, 1C	–38.5	00, 03, 0B	–53.5	00, 00, 8B
6.0	01, FE, CA	–9.0	00, 5A, D5	–24.0	00, 10, 27	–39.0	00, 02, DF	–54.0	00, 00, 83
5.5	01, E2, 37	–9.5	00, 55, C0	–24.5	00, 0F, 40	–39.5	00, 02, B6	–54.5	00, 00, 7B
5.0	01, C7, 3D	–10.0	00, 50, F4	–25.0	00, 0E, 65	–40.0	00, 02, 8F	–55.0	00, 00, 75
4.5	01, AD, C6	–10.5	00, 4C, 6D	–25.5	00, 0D, 97	–40.5	00, 02, 6B	–55.5	00, 00, 6E
4.0	01, 95, BC	–11.0	00, 48, 27	–26.0	00, 0C, D5	–41.0	00, 02, 48	–56.0	00, 00, 68
3.5	01, 7F, 09	–11.5	00, 44, 1D	–26.5	00, 0C, 1D	–41.5	00, 02, 27	–56.5	00, 00, 62

**Table A-5. Volume Versus Gain Values (Continued)**

GAIN (dB)	VOLUME V(23-16), V(15-8), V(7-0)	GAIN (dB)	VOLUME V(23-16), V(15-8), V(7-0)	GAIN (dB)	VOLUME V(23-16), V(15-8), V(7-0)	GAIN (dB)	VOLUME V(23-16), V(15-8), V(7-0)	GAIN (dB)	VOLUME V(23-16), V(15-8), V(7-0)
-57.0	00, 00, 5D	-60.0	00, 00, 42	-63.0	00, 00, 2E	-66.0	00, 00, 21	-69.0	00, 00, 17
-57.5	00, 00, 57	-60.5	00, 00, 3E	-63.5	00, 00, 2C	-66.5	00, 00, 1F	-69.5	00, 00, 16
-58.0	00, 00, 53	-61.0	00, 00, 3A	-64.0	00, 00, 29	-67.0	00, 00, 1D	-70.0	00, 00, 15
-58.5	00, 00, 4E	-61.5	00, 00, 37	-64.5	00, 00, 27	-67.5	00, 00, 1C	mute	00, 00, 00
-59.0	00, 00, 4A	-62.0	00, 00, 34	-65.0	00, 00, 25	-68.0	00, 00, 1A		
-59.5	00, 00, 45	-62.5	00, 00, 31	-65.5	00, 00, 23	-68.5	00, 00, 19		

### A.3 Treble Control Register Command

Both left and right channel are given the same treble gain setting.

Device ID	Subaddress	T(7-0)
-----------	------------	--------

For example, if treble gain = 5 dB, then the command is:

68	05	65
----	----	----

**Table A-6. Treble Control Register**

GAIN (dB)	T(7-0) (hex)	GAIN (dB)	T(7-0) (hex)	GAIN (dB)	T(7-0) (hex)	GAIN (dB)	T(7-0) (hex)	GAIN (dB)	T(7-0) (hex)
18.0	0x01	10.5	0x4A	3.0	0x6B	-4.5	0x7B	-12.0	0x8A
17.5	0x01	10.0	0x4D	2.5	0x6C	-5.0	0x7C	-12.5	0x8B
17.0	0x04	9.5	0x51	2.0	0x6D	-5.5	0x7D	-13.0	0x8C
16.5	0x08	9.0	0x53	1.5	0x3F	-6.0	0x7E	-13.5	0x8D
16.0	0x13	8.5	0x56	1.0	0x70	-6.5	0x7F	-14.0	0x8E
15.5	0x1A	8.0	0x59	0.5	0x71	-7.0	0x80	-14.5	0x8F
15.0	0x20	7.5	0x5B	0.0	0x72	-7.5	0x81	-15.0	0x90
14.5	0x26	7.0	0x5D	-0.5	0x73	-8.0	0x82	-15.5	0x91
14.0	0x2C	6.5	0x60	-1.0	0x74	-8.5	0x83	-16.0	0x92
13.5	0x31	6.0	0x62	-1.5	0x75	-9.0	0x84	-16.5	0x93
13.0	0x36	5.5	0x63	-2.0	0x76	-9.5	0x85	-17.0	0x94
12.5	0x3B	5.0	0x65	-2.5	0x77	-10.0	0x86	-17.5	0x95
12.0	0x3F	4.5	0x67	-3.0	0x78	-10.5	0x87	-18.0	0x96
11.5	0x43	4.0	0x68	-3.5	0x79	-11.0	0x88		
11.0	0x47	3.5	0x69	-4.0	0x7A	-11.5	0x89		

## A.4 Bass Control Register Command

Both left and right channel are given the same bass gain setting.

Device ID	Subaddress	B(7-0)
-----------	------------	--------

For example, if bass gain = 5 dB, then the command is:

68	06	2B
----	----	----

**Table A-7. Bass Control Register**

GAIN (dB)	B(7-0) (hex)	GAIN (dB)	B(7-0) (hex)	GAIN (dB)	B(7-0) (hex)	GAIN (dB)	B(7-0) (hex)	GAIN (dB)	B(7-0) (hex)
18.0	0x01	10.5	0x4C	3.0	0x6A	-4.5	0x7B	-12.0	0x8A
17.5	0x0A	10.0	0x4F	2.5	0x6B	-5.0	0x7C	-12.5	0x8B
17.0	0x11	9.5	0x52	2.0	0x6D	-5.5	0x7D	-13.0	0x8C
16.5	0x18	9.0	0x55	1.5	0x6E	-6.0	0x7E	-13.5	0x8D
16.0	0x1E	8.5	0x58	1.0	0x6F	-6.5	0x7F	-14.0	0x8E
15.5	0x24	8.0	0x5B	0.5	0x71	-7.0	0x80	-14.5	0x8F
15.0	0x29	7.5	0x5D	0.0	0x72	-7.5	0x81	-15.0	0x90
14.5	0x2E	7.0	0x5F	-0.5	0x73	-8.0	0x82	-15.5	0x91
14.0	0x33	6.5	0x61	-1.0	0x74	-8.5	0x83	-16.0	0x92
13.5	0x37	6.0	0x62	-1.5	0x75	-9.0	0x84	-16.5	0x93
13.0	0x3B	5.5	0x63	-2.0	0x76	-9.5	0x85	-17.0	0x94
12.5	0x3F	5.0	0x65	-2.5	0x77	-10.0	0x86	-17.5	0x95
12.0	0x43	4.5	0x66	-3.0	0x78	-10.5	0x87	-18.0	0x96
11.5	0x46	4.0	0x67	-3.5	0x79	-11.0	0x88		
11.0	0x49	3.5	0x69	-4.0	0x7A	-11.5	0x89		

## A.5 I<sup>2</sup>C Mixer Register Command

The gain error is less than 0.12 dB, excluding mute.

Device ID	Subaddress	Mixer1	Mixer2	ADC Mixer
-----------	------------	--------	--------	-----------

For example, if Sdin1 Mix = +6dB, Sdin2 Mix = 0dB, and ADC Mix = Mute, then the command is:

### Left

68	07	1F EC 98	10 00 00	00 00 00
----	----	----------	----------	----------

### Right

68	08	1F EC 98	10 00 00	00 00 00
----	----	----------	----------	----------

Even if only one of the mixers needs to be changed, the whole command must be sent.

**Table A-8. Mixer1 and Mixer2 Gain Values**

GAIN (dB)	GAIN S(23-16), S(15-8), S(7-0)	GAIN (dB)	GAIN S(23-16), S(15-8), S(7-0)	GAIN (dB)	GAIN S(23-16), S(15-8), S(7-0)	GAIN (dB)	GAIN S(23-16), S(15-8), S(7-0)	GAIN (dB)	GAIN S(23-16), S(15-8), S(7-0)
18.0	7F, 17, AF	0.0	10, 00, 00	-18.0	02, 03, A7	-36.0	00, 40, EA	-54.0	00, 08, 2C
17.5	77, FB, AA	-0.5	0F, 1A, DF	-18.5	01, E6, CF	-36.5	00, 3D, 49	-54.5	00, 07, B7
17.0	71, 45, 75	-1.0	0E, 42, 90	-19.0	01, CB, 94	-37.0	00, 39, DB	-55.0	00, 07, 48
16.5	6A, EF, 5D	-1.5	0D, 76, 5A	-19.5	01, B1, DE	-37.5	00, 36, 9E	-55.5	00, 06, E0
16.0	64, F4, 03	-2.0	0C, B5, 91	-20.0	01, 99, 99	-38.0	00, 33, 90	-56.0	00, 06, 7D
15.5	5F, 4E, 52	-2.5	0B, FF, 91	-20.5	01, 82, AF	-38.5	00, 30, AE	-56.5	00, 06, 20
15.0	59, F9, 80	-3.0	0B, 53, BE	-21.0	01, 6D, 0E	-39.0	00, 2D, F5	-57.0	00, 05, C9
14.5	54, F1, 06	-3.5	0A, B1, 89	-21.5	01, 58, A2	-39.5	00, 2B, 63	-57.5	00, 05, 76
14.0	50, 30, A1	-4.0	0A, 18, 66	-22.0	01, 45, 5B	-40.0	00, 28, F5	-58.0	00, 05, 28
13.5	4B, B4, 46	-4.5	09, 87, D5	-22.5	01, 33, 28	-40.5	00, 26, AB	-58.5	00, 04, DE
13.0	47, 78, 28	-5.0	08, FF, 59	-23.0	01, 21, F9	-41.0	00, 24, 81	-59.0	00, 04, 98
12.5	43, 78, B0	-5.5	08, 7E, 80	-23.5	01, 11, C0	-41.5	00, 22, 76	-59.5	00, 04, 56
12.0	3F, B2, 78	-6.0	08, 04, DC	-24.0	01, 02, 70	-42.0	00, 20, 89	-60.0	00, 04, 18
11.5	3C, 22, 4C	-6.5	07, 92, 07	-24.5	00, F3, FB	-42.5	00, 1E, B7	-60.5	00, 03, DD
11.0	38, C5, 28	-7.0	07, 25, 9D	-25.0	00, E6, 55	-43.0	00, 1C, FF	-61.0	00, 03, A6
10.5	35, 98, 2F	-7.5	06, BF, 44	-25.5	00, D9, 73	-43.5	00, 1B, 60	-61.5	00, 03, 72
10.0	32, 98, B0	-8.0	06, 5E, A5	-26.0	00, CD, 49	-44.0	00, 19, D8	-62.0	00, 03, 40
9.5	2F, C4, 20	-8.5	06, 03, 6E	-26.5	00, C1, CD	-44.5	00, 18, 65	-62.5	00, 03, 12
9.0	2D, 18, 18	-9.0	05, AD, 50	-27.0	00, B6, F6	-45.0	00, 17, 08	-63.0	00, 02, E6
8.5	2A, 92, 54	-9.5	05, 5C, 04	-27.5	00, AC, BA	-45.5	00, 15, BE	-63.5	00, 02, BC
8.0	28, 30, AF	-10.0	05, 0F, 44	-28.0	00, A3, 10	-46.0	00, 14, 87	-64.0	00, 02, 95
7.5	25, F1, 25	-10.5	04, C6, D0	-28.5	00, 99, F1	-46.5	00, 13, 61	-64.5	00, 02, 70
7.0	23, D1, CD	-11.0	04, 82, 68	-29.0	00, 91, 54	-47.0	00, 12, 4B	-65.0	00, 02, 4D
6.5	21, D0, D9	-11.5	04, 41, D5	-29.5	00, 89, 33	-47.5	00, 11, 45	-65.5	00, 02, 2C
6.0	1F, EC, 98	-12.0	04, 04, DE	-30.0	00, 81, 86	-48.0	00, 10, 4E	-66.0	00, 02, 0D
5.5	1E, 23, 6D	-12.5	03, CB, 50	-30.5	00, 7A, 48	-48.5	00, 0F, 64	-66.5	00, 01, F0
5.0	1C, 73, D5	-13.0	03, 94, FA	-31.0	00, 73, 70	-49.0	00, 0E, 88	-67.0	00, 01, D4
4.5	1A, DC, 61	-13.5	03, 61, AF	-31.5	00, 6C, FB	-49.5	00, 0D, B8	-67.5	00, 01, BA
4.0	19, 5B, B8	-14.0	03, 31, 42	-32.0	00, 66, E3	-50.0	00, 0C, F3	-68.0	00, 01, A1
3.5	17, F0, 94	-14.5	03, 03, 8A	-32.5	00, 61, 21	-50.5	00, 0C, 3A	-68.5	00, 01, 8A
3.0	16, 99, C0	-15.0	02, D8, 62	-33.0	00, 5B, B2	-51.0	00, 0B, 8B	-69.0	00, 01, 74
2.5	15, 56, 1A	-15.5	02, AF, A3	-33.5	00, 56, 91	-51.5	00, 0A, E5	-69.5	00, 01, 5F
2.0	14, 24, 8E	-16.0	02, 89, 2C	-34.0	00, 51, B9	-52.0	00, 0A, 49	-70.0	00, 01, 4B
1.5	13, 04, 1A	-16.5	02, 64, DB	-34.5	00, 4D, 27	-52.5	00, 09, B6	Mute	00, 00, 00
1.0	11, F3, C9	-17.0	02, 42, 93	-35.0	00, 48, D6	-53.0	00, 09, 2B		
0.5	10, F2, B4	-17.5	02, 22, 35	-35.5	00, 44, C3	-53.5	00, 08, A8		

## A.6 Programming Instruction for the Loudness Contour

The gain error is less than 0.12 dB, excluding mute.

Device ID	Subaddress	B0(23-0)	B1(23-0)	B2(23-0)	A1(23-0)	A2(23-0)
-----------	------------	----------	----------	----------	----------	----------

For example:

Left Loudness Biquad

68	21	001A82	000000	FFE57E	E03550	0FCABB
----	----	--------	--------	--------	--------	--------

Right Loudness Biquad

68	22	001A82	000000	FFE57E	E03550	0FCABB
----	----	--------	--------	--------	--------	--------

Left Loudness Biquad Gain

Sub

G(23-0)

68	23	04C6D0
----	----	--------

Right Loudness Biquad Gain

68	24	04C6D0
----	----	--------

## A.7 Examples of DRCE

The gain error is less than 0.12 dB (excluding mute).

**Table A-9. Example of a DRCE I<sup>2</sup>C Instruction With DRCE On**

BYTE NUMBER	INSTRUCTION (HEX)	INSTRUCTION DEFINITION	TABLE
1	68	TAS3004 device identification	
2	02	DRC subaddress	
3	68	Above-threshold ratio of 5.33:1 with DRCE on	See Table A-11 and Table A-12
4	22	Below-threshold ratio of 1.33:1	See Table A-13 and Table A-14
5	9F	Threshold of -30 dB	See Table A-15
6	B0	Integration interval for energy level detection of 212 ms	See Table A-16
7	60	Attack time constant 6.7 ms	
8	A0	Decay time constant 106 ms	

### A.7.1 DRCE On/Off

The DRCE default mode in the TAS3004 device is off.

The DRCE turns on if all eight bytes in Table A-9 are transmitted and the LSB of the above threshold ratio byte is 0.

The DRCE turns off if all eight bytes in Table A-10 are transmitted and the LSB of the above threshold ratio byte is 1. Table A-10 is identical to Table A-9 except for this third byte.

**Table A-10. Example of a DRCE I<sup>2</sup>C Instruction With DRCE Off**

BYTE NUMBER	INSTRUCTION (HEX)	INSTRUCTION DEFINITION	TABLE
1	68	TAS3004 device identification	
2	02	DRC subaddress	
3	69	Above threshold ratio of 5.33:1 with DRCE off	See Table A-11 and Table A-12
4	22	Below threshold ratio of 1.33:1	See Table A-13 and Table A-14
5	9F	Threshold of -30 dB	See Table A-15
6	B0	Integration interval for energy level detection of 212 ms	See Table A-16
7	60	Attack time constant 6.7 ms	
8	A0	Decay time constant 106 ms	

## A.7.2 Above Threshold Ratios

The above threshold ratios are applied when the energy level of the incoming signal is detected anywhere between the threshold (from Table A-15) and 0 dB. See Figure A-1.

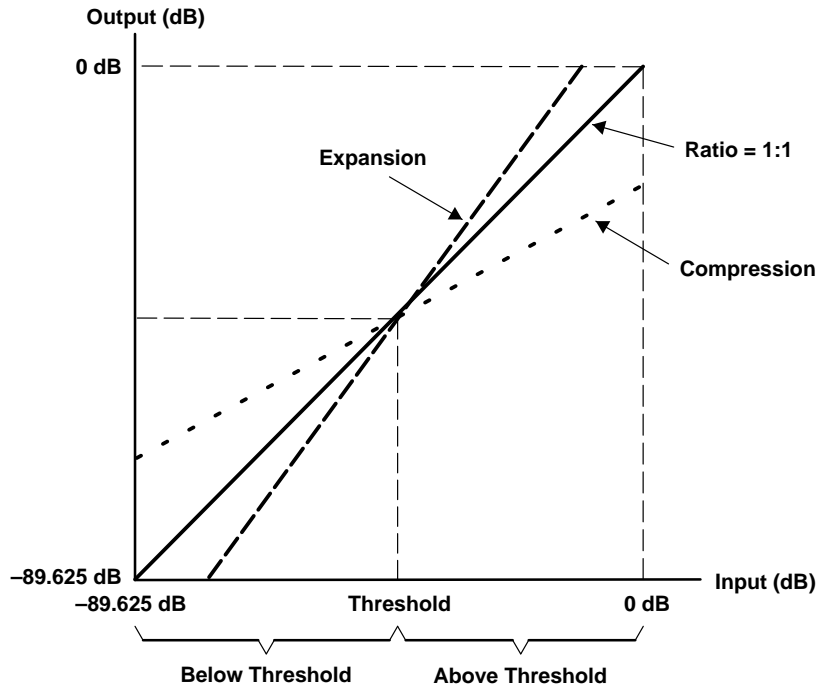

Figure A-1. TAS3004 DRCE Characteristics in the dB Domain

Table A-11. Above Threshold Ratios for Compression

HEXADECIMAL VALUE	RATIO (IN:OUT)
02	1.00 : 1
08	1.07 : 1
10	1.14 : 1
18	1.23 : 1
20	1.33 : 1
28	1.45 : 1
30	1.60 : 1
38	1.78 : 1
40	2.00 : 1
48	2.29 : 1
50	2.67 : 1
58	3.20 : 1
60	4.00 : 1
68	5.33 : 1
70	8.00 : 1
78	16.0 : 1

**Table A–12. Above Threshold Ratios for Expansion**

HEXADECIMAL VALUE	RATIO (IN:OUT)
02	1 : 1.00
0A	1 : 1.06
12	1 : 1.13
1A	1 : 1.19
22	1 : 1.25
2A	1 : 1.31
32	1 : 1.38
3A	1 : 1.44
42	1 : 1.50

**A.7.3 Below Threshold Ratios**

The below threshold ratios are applied when the energy level of the incoming signal is detected as being anywhere between the threshold (from Table A–15) and –89.625 dB. See Figure A–1.

**Table A–13. Below Threshold Ratios for Expansion**

HEXADECIMAL VALUE	RATIO (IN:OUT)
02	1 : 1.00
08	1 : 1.06
10	1 : 1.13
18	1 : 1.19
20	1 : 1.25
28	1 : 1.31
30	1 : 1.38
38	1 : 1.44
40	1 : 1.50
48	1 : 1.56
50	1 : 1.63
58	1 : 1.69
60	1 : 1.75
68	1 : 1.81
70	1 : 1.88
78	1 : 1.94
80	1 : 2.00

**Table A–14. Below Threshold Ratios for Compression**

HEXADECIMAL VALUE	RATIO (IN:OUT)
02	1.00 : 1
0A	1.07 : 1
12	1.14 : 1
1A	1.23 : 1
22	1.33 : 1
2A	1.45 : 1
32	1.60 : 1
3A	1.78 : 1
42	2.00 : 1

## A.7.4 Threshold

Table A–15 lists a range of threshold values from 0 dB to –89.625 dB in 0.75-dB decrements.

**NOTE:** The TAS3004 device is capable of 0.375-dB increments. The associated hexadecimal value can be determined by interpolating between the existing hexadecimal values in Table A–15.

**Table A–15. Threshold Values**

HEX VALUE	dB	HEX VALUE	dB	HEX VALUE	dB	HEX VALUE	dB	HEX VALUE	dB
EF	0	BD	–18.75	8B	–37.50	59	–56.25	27	–75.00
ED	–0.75	BB	–19.50	89	–38.25	57	–57.00	25	–75.75
EB	–1.50	B9	–20.25	87	–39.00	55	–57.75	23	–76.50
E9	–2.25	B7	–21.00	85	–39.75	53	–58.50	21	–77.25
E7	–3.00	B5	–21.75	83	–40.50	51	–59.25	1F	–78.00
E5	–3.75	B3	–22.50	81	–41.25	4F	–60.00	1D	–78.75
E3	–4.50	B1	–23.25	7F	–42.00	4D	–60.75	1B	–79.50
E1	–5.25	AF	–24.00	7D	–42.75	4B	–61.50	19	–80.25
DF	–6.00	AD	–24.75	7B	–43.50	49	–62.25	17	–80.00
DD	–6.75	AB	–25.50	79	–44.25	47	–63.00	15	–81.75
DB	–7.50	A9	–26.25	77	–45.00	45	–63.75	13	–82.50
D9	–8.25	A7	–27.00	75	–45.75	43	–64.50	11	–83.25
D7	–9.00	A5	–27.75	73	–46.50	41	–65.25	0F	–84.00
D5	–9.75	A3	–28.50	71	–47.25	3F	–66.00	0D	–84.75
D3	–10.50	A1	–29.25	6F	–48.00	3D	–66.75	0B	–85.50
D1	–11.25	9F	–30.00	6D	–48.75	3B	–67.50	09	–86.25
CF	–12.00	9D	–30.75	6B	–49.50	39	–68.25	07	–87.00
CD	–12.75	9B	–31.50	69	–50.25	37	–69.00	05	–87.75
CB	–13.50	99	–32.25	67	–51.00	35	–69.75	03	–88.50
C9	–14.25	97	–33.00	65	–51.75	33	–70.50	01	–89.25
C7	–15.00	95	–33.75	63	–52.50	31	–71.25	00	–89.625
C5	–15.75	93	–34.50	61	–53.25	2F	–72.00		
C3	–16.50	91	–35.25	5F	–54.00	2D	–72.75		
C1	–17.25	8F	–36.00	5D	–54.75	2B	–73.50		
BF	–18.00	8D	–36.75	5B	–55.50	29	–74.25		

## A.7.5 Time Constants

Use Table A–16 to program the attack time, the decay time, and the integration interval for energy level detection.

Level detection is performed by using an alpha filter at the input of the DRCE, which functions as an energy-level detection block for the DRCE. The time constant for level detection can be thought of as an integration interval. Use a time constant from Table A–16 as an integration interval for energy level detection.

Table A–16 lists the time constants used for integration interval for energy level detection, attack time constant, and decay time constant. All values represent the time required to reach 63% of maximum value from zero.

**Table A-16. Time Constants**

HEXADECIMAL VALUE	TIME DELAY
40	1.7 ms
50	3.5 ms
60	6.7 ms
70	13 ms
80	26 ms
90	53 ms
A0	106 ms
B0	212 ms
C0	425 ms
D0	850 ms
E0	1.7 s
F0	2.4 s

**A.7.6 DRCE Example With Threshold at -12 dB**

From the DRCE example shown in Figure A-2, the threshold is set at -12 dB. The input energy E, has a value of -6 dB.

$$\begin{aligned}
 \text{Output (dB)} &= [T(\text{dB}) + (E(\text{dB}) - T(\text{dB})) \times (1/\text{CR})] \\
 &= [-12 + (-6 - (-12)) \times (1/3)] \text{ dB} \\
 &= -12 + 2 = -10 \text{ dB}
 \end{aligned}$$

Where:

CR = Compression Ratio

T = Threshold (dB)

E = Energy estimate of current input

Note: Energy of sine wave is approximately 3 dB lower than peak.

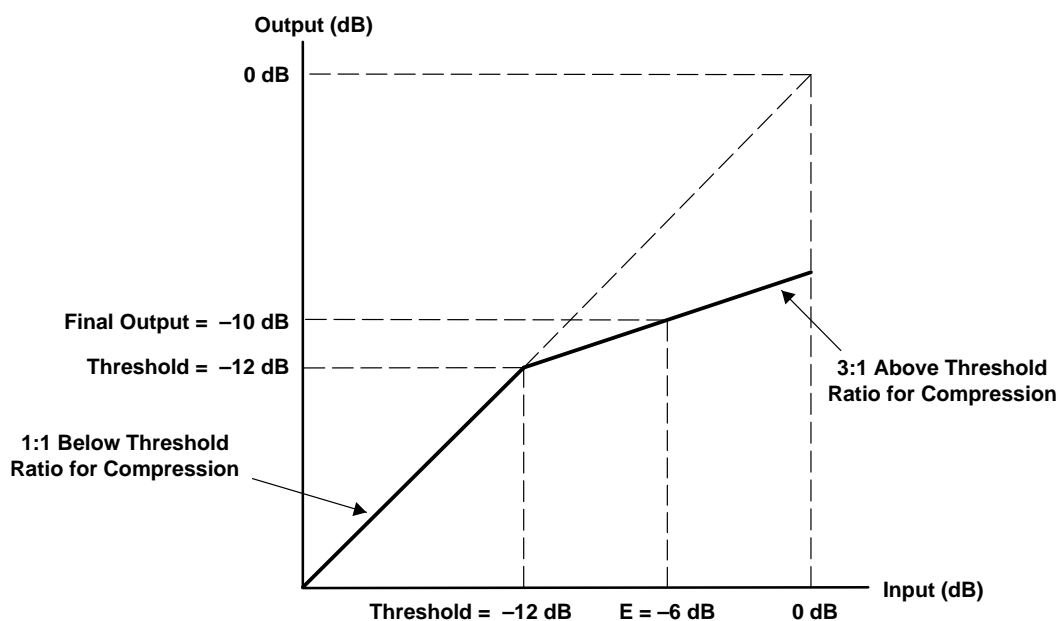

**Figure A-2. DRCE Example With Threshold at -12 dB**

**PACKAGING INFORMATION**

Orderable Device	Status <sup>(1)</sup>	Package Type	Package Drawing	Pins	Package Qty	Eco Plan <sup>(2)</sup>	Lead/ Ball Finish	MSL Peak Temp <sup>(3)</sup>	Samples (Requires Login)
TAS3004PFB	ACTIVE	TQFP	PFB	48	250	Green (RoHS & no Sb/Br)	CU NIPDAU	Level-2-260C-1 YEAR	
TAS3004PFBG4	ACTIVE	TQFP	PFB	48	250	Green (RoHS & no Sb/Br)	CU NIPDAU	Level-2-260C-1 YEAR	
TAS3004PFBR	ACTIVE	TQFP	PFB	48	1000	Green (RoHS & no Sb/Br)	CU NIPDAU	Level-2-260C-1 YEAR	
TAS3004PFBRG4	ACTIVE	TQFP	PFB	48	1000	Green (RoHS & no Sb/Br)	CU NIPDAU	Level-2-260C-1 YEAR	

<sup>(1)</sup> The marketing status values are defined as follows:

**ACTIVE:** Product device recommended for new designs.

**LIFEBUY:** TI has announced that the device will be discontinued, and a lifetime-buy period is in effect.

**NRND:** Not recommended for new designs. Device is in production to support existing customers, but TI does not recommend using this part in a new design.

**PREVIEW:** Device has been announced but is not in production. Samples may or may not be available.

**OBSOLETE:** TI has discontinued the production of the device.

<sup>(2)</sup> Eco Plan - The planned eco-friendly classification: Pb-Free (RoHS), Pb-Free (RoHS Exempt), or Green (RoHS & no Sb/Br) - please check <http://www.ti.com/productcontent> for the latest availability information and additional product content details.

**TBD:** The Pb-Free/Green conversion plan has not been defined.

**Pb-Free (RoHS):** TI's terms "Lead-Free" or "Pb-Free" mean semiconductor products that are compatible with the current RoHS requirements for all 6 substances, including the requirement that lead not exceed 0.1% by weight in homogeneous materials. Where designed to be soldered at high temperatures, TI Pb-Free products are suitable for use in specified lead-free processes.

**Pb-Free (RoHS Exempt):** This component has a RoHS exemption for either 1) lead-based flip-chip solder bumps used between the die and package, or 2) lead-based die adhesive used between the die and leadframe. The component is otherwise considered Pb-Free (RoHS compatible) as defined above.

**Green (RoHS & no Sb/Br):** TI defines "Green" to mean Pb-Free (RoHS compatible), and free of Bromine (Br) and Antimony (Sb) based flame retardants (Br or Sb do not exceed 0.1% by weight in homogeneous material)

<sup>(3)</sup> MSL, Peak Temp. -- The Moisture Sensitivity Level rating according to the JEDEC industry standard classifications, and peak solder temperature.

**Important Information and Disclaimer:** The information provided on this page represents TI's knowledge and belief as of the date that it is provided. TI bases its knowledge and belief on information provided by third parties, and makes no representation or warranty as to the accuracy of such information. Efforts are underway to better integrate information from third parties. TI has taken and continues to take reasonable steps to provide representative and accurate information but may not have conducted destructive testing or chemical analysis on incoming materials and chemicals. TI and TI suppliers consider certain information to be proprietary, and thus CAS numbers and other limited information may not be available for release.

In no event shall TI's liability arising out of such information exceed the total purchase price of the TI part(s) at issue in this document sold by TI to Customer on an annual basis.

## TAPE AND REEL INFORMATION

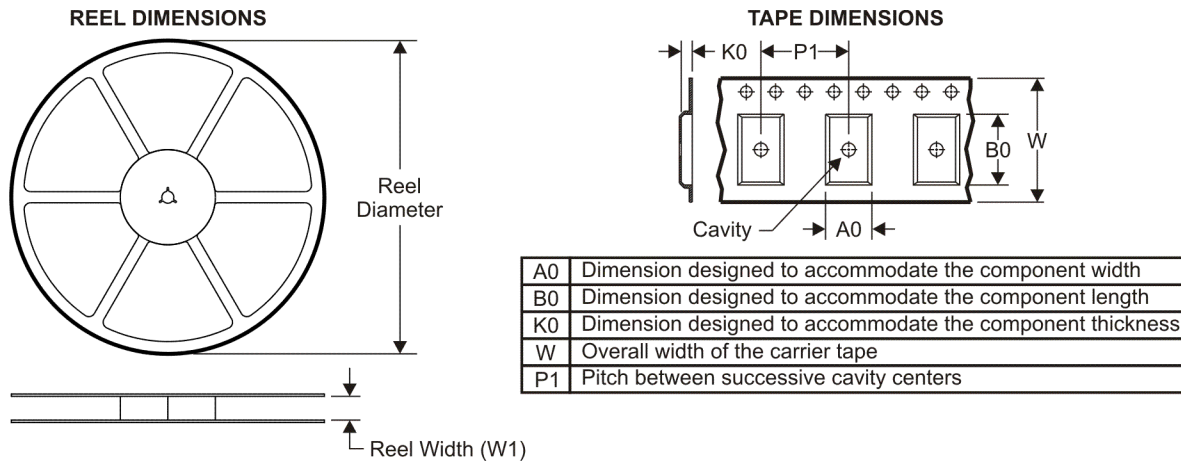

### QUADRANT ASSIGNMENTS FOR PIN 1 ORIENTATION IN TAPE

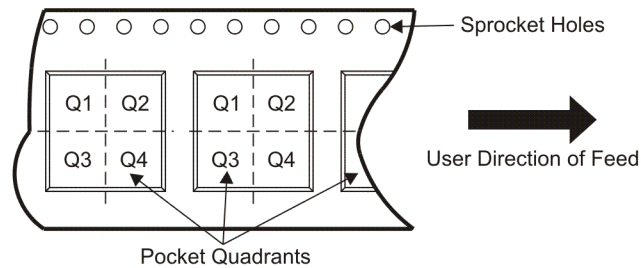

\*All dimensions are nominal

Device	Package Type	Package Drawing	Pins	SPQ	Reel Diameter (mm)	Reel Width W1 (mm)	A0 (mm)	B0 (mm)	K0 (mm)	P1 (mm)	W (mm)	Pin1 Quadrant
TAS3004PFBR	TQFP	PFB	48	1000	330.0	16.4	9.6	9.6	1.5	12.0	16.0	Q2

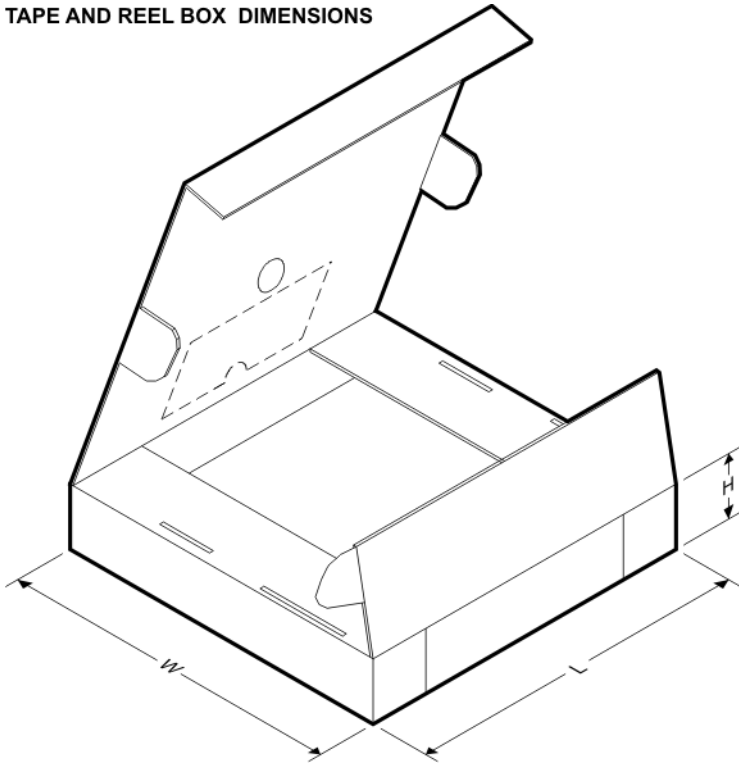
**TAPE AND REEL BOX DIMENSIONS**

\*All dimensions are nominal

Device	Package Type	Package Drawing	Pins	SPQ	Length (mm)	Width (mm)	Height (mm)
TAS3004PFBR	TQFP	PFB	48	1000	346.0	346.0	33.0

PFB (S-PQFP-G48)

PLASTIC QUAD FLATPACK

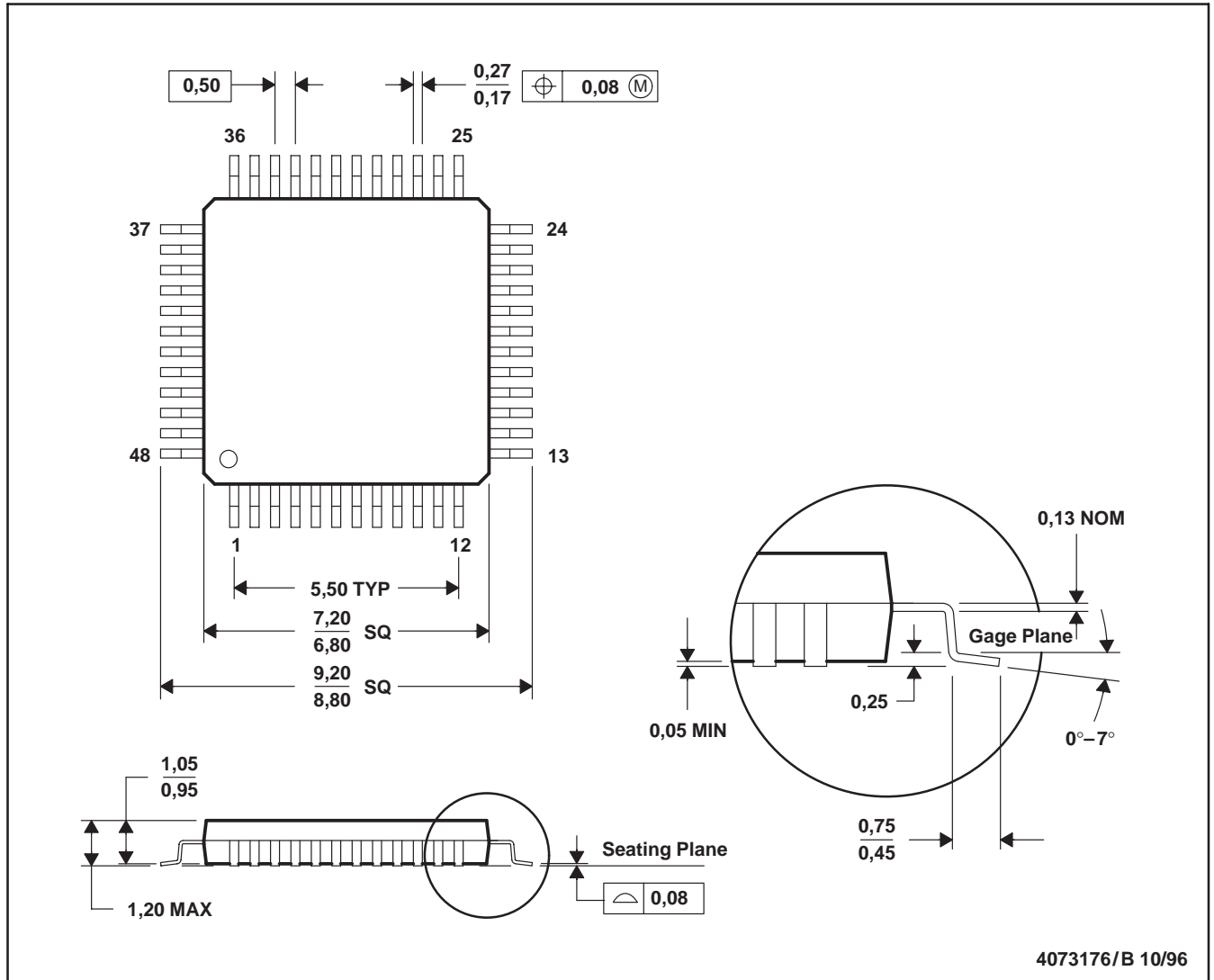

- NOTES: A. All linear dimensions are in millimeters.  
 B. This drawing is subject to change without notice.  
 C. Falls within JEDEC MS-026

PFB (S-PQFP-G48)

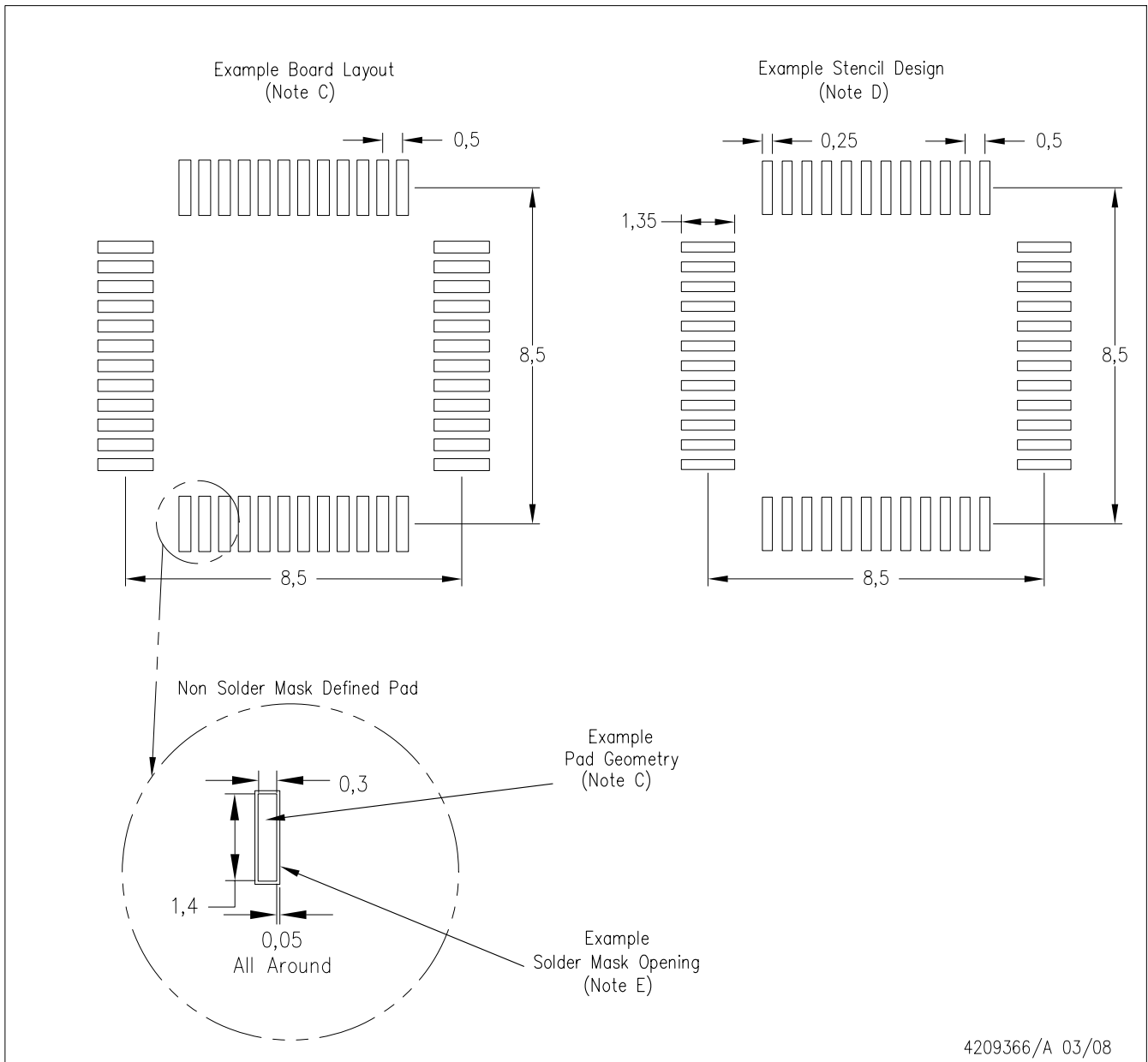

- NOTES:
- A. All linear dimensions are in millimeters.
  - B. This drawing is subject to change without notice.
  - C. Publication IPC-7351 is recommended for alternate designs.
  - D. Laser cutting apertures with trapezoidal walls and also rounding corners will offer better paste release. Customers should contact their board assembly site for stencil design recommendations. Refer to IPC-7525.
  - E. Customers should contact their board fabrication site for solder mask tolerances between and around signal pads.

## IMPORTANT NOTICE

Texas Instruments Incorporated and its subsidiaries (TI) reserve the right to make corrections, modifications, enhancements, improvements, and other changes to its products and services at any time and to discontinue any product or service without notice. Customers should obtain the latest relevant information before placing orders and should verify that such information is current and complete. All products are sold subject to TI's terms and conditions of sale supplied at the time of order acknowledgment.

TI warrants performance of its hardware products to the specifications applicable at the time of sale in accordance with TI's standard warranty. Testing and other quality control techniques are used to the extent TI deems necessary to support this warranty. Except where mandated by government requirements, testing of all parameters of each product is not necessarily performed.

TI assumes no liability for applications assistance or customer product design. Customers are responsible for their products and applications using TI components. To minimize the risks associated with customer products and applications, customers should provide adequate design and operating safeguards.

TI does not warrant or represent that any license, either express or implied, is granted under any TI patent right, copyright, mask work right, or other TI intellectual property right relating to any combination, machine, or process in which TI products or services are used. Information published by TI regarding third-party products or services does not constitute a license from TI to use such products or services or a warranty or endorsement thereof. Use of such information may require a license from a third party under the patents or other intellectual property of the third party, or a license from TI under the patents or other intellectual property of TI.

Reproduction of TI information in TI data books or data sheets is permissible only if reproduction is without alteration and is accompanied by all associated warranties, conditions, limitations, and notices. Reproduction of this information with alteration is an unfair and deceptive business practice. TI is not responsible or liable for such altered documentation. Information of third parties may be subject to additional restrictions.

Resale of TI products or services with statements different from or beyond the parameters stated by TI for that product or service voids all express and any implied warranties for the associated TI product or service and is an unfair and deceptive business practice. TI is not responsible or liable for any such statements.

TI products are not authorized for use in safety-critical applications (such as life support) where a failure of the TI product would reasonably be expected to cause severe personal injury or death, unless officers of the parties have executed an agreement specifically governing such use. Buyers represent that they have all necessary expertise in the safety and regulatory ramifications of their applications, and acknowledge and agree that they are solely responsible for all legal, regulatory and safety-related requirements concerning their products and any use of TI products in such safety-critical applications, notwithstanding any applications-related information or support that may be provided by TI. Further, Buyers must fully indemnify TI and its representatives against any damages arising out of the use of TI products in such safety-critical applications.

TI products are neither designed nor intended for use in military/aerospace applications or environments unless the TI products are specifically designated by TI as military-grade or "enhanced plastic." Only products designated by TI as military-grade meet military specifications. Buyers acknowledge and agree that any such use of TI products which TI has not designated as military-grade is solely at the Buyer's risk, and that they are solely responsible for compliance with all legal and regulatory requirements in connection with such use.

TI products are neither designed nor intended for use in automotive applications or environments unless the specific TI products are designated by TI as compliant with ISO/TS 16949 requirements. Buyers acknowledge and agree that, if they use any non-designated products in automotive applications, TI will not be responsible for any failure to meet such requirements.

Following are URLs where you can obtain information on other Texas Instruments products and application solutions:

### Products

Audio	<a href="http://www.ti.com/audio">www.ti.com/audio</a>
Amplifiers	<a href="http://amplifier.ti.com">amplifier.ti.com</a>
Data Converters	<a href="http://dataconverter.ti.com">dataconverter.ti.com</a>
DLP® Products	<a href="http://www.dlp.com">www.dlp.com</a>
DSP	<a href="http://dsp.ti.com">dsp.ti.com</a>
Clocks and Timers	<a href="http://www.ti.com/clocks">www.ti.com/clocks</a>
Interface	<a href="http://interface.ti.com">interface.ti.com</a>
Logic	<a href="http://logic.ti.com">logic.ti.com</a>
Power Mgmt	<a href="http://power.ti.com">power.ti.com</a>
Microcontrollers	<a href="http://microcontroller.ti.com">microcontroller.ti.com</a>
RFID	<a href="http://www.ti-rfid.com">www.ti-rfid.com</a>
RF/IF and ZigBee® Solutions	<a href="http://www.ti.com/lprf">www.ti.com/lprf</a>

### Applications

Communications and Telecom	<a href="http://www.ti.com/communications">www.ti.com/communications</a>
Computers and Peripherals	<a href="http://www.ti.com/computers">www.ti.com/computers</a>
Consumer Electronics	<a href="http://www.ti.com/consumer-apps">www.ti.com/consumer-apps</a>
Energy and Lighting	<a href="http://www.ti.com/energy">www.ti.com/energy</a>
Industrial	<a href="http://www.ti.com/industrial">www.ti.com/industrial</a>
Medical	<a href="http://www.ti.com/medical">www.ti.com/medical</a>
Security	<a href="http://www.ti.com/security">www.ti.com/security</a>
Space, Avionics and Defense	<a href="http://www.ti.com/space-avionics-defense">www.ti.com/space-avionics-defense</a>
Transportation and Automotive	<a href="http://www.ti.com/automotive">www.ti.com/automotive</a>
Video and Imaging	<a href="http://www.ti.com/video">www.ti.com/video</a>
Wireless	<a href="http://www.ti.com/wireless-apps">www.ti.com/wireless-apps</a>

TI E2E Community Home Page

[e2e.ti.com](http://e2e.ti.com)

Mailing Address: Texas Instruments, Post Office Box 655303, Dallas, Texas 75265  
Copyright © 2011, Texas Instruments Incorporated

## Looking for pricing, stock, or lifecycle information?

Click below to explore more details on WIN SOURCE:

 [View TAS3004PFBG4 on WIN SOURCE](#)

 [Texas Instruments](#) Information

## Optimize Your Supply Chain with WIN SOURCE Solutions

-  Global Sourcing Solution
-  Obsolete Management
-  Cost Control Management
-  Shortage Management
-  Alternative Solution
-  Excess Inventory Management