

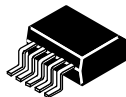

**THE DATASHEET OF
TPS75618KTT**

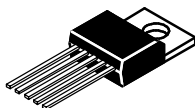



FAST-TRANSIENT RESPONSE 5-A LOW-DROPOUT VOLTAGE REGULATORS

FEATURES

- 5-A Low-Dropout Voltage Regulator
- Available in 1.5-V, 1.8-V, 2.5-V, and 3.3-V Fixed-Output and Adjustable Versions
- Dropout Voltage Typically 250 mV at 5 A (TPS75633)
- Low 125 μ A Typical Quiescent Current
- Fast Transient Response
- 3% Tolerance Over Specified Conditions for Fixed-Output Versions
- Available in 5-Pin TO-220 and TO-263 Surface-Mount Packages
- Thermal Shutdown Protection

DESCRIPTION

The TPS756xx family of 5-A low dropout (LDO) regulators contains four fixed voltage option regulators and an adjustable voltage option regulator. These devices are capable of supplying 5 A of output current with a dropout of 250 mV (TPS75633). Therefore, the device is capable of performing a 3.3-V to 2.5-V conversion.

Quiescent current is 125 μ A at full load and drops down to less than 1 μ A when the device is disabled. The TPS756xx is designed to have fast transient response for large load current changes.

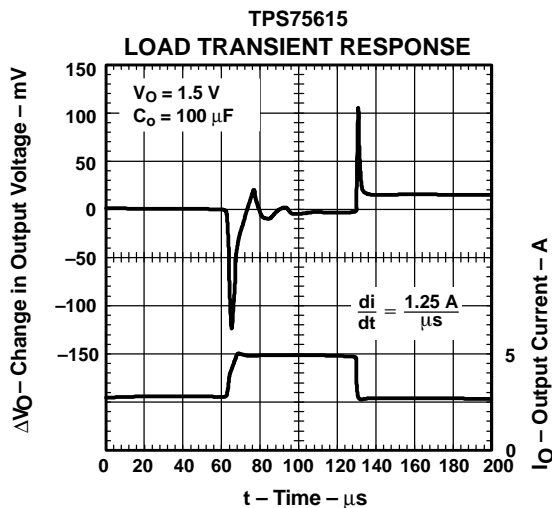
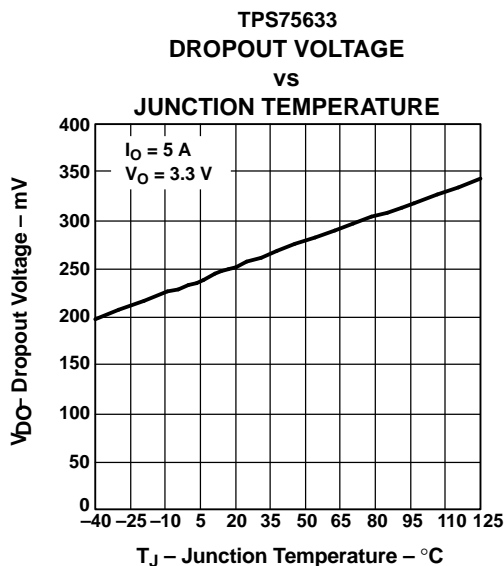
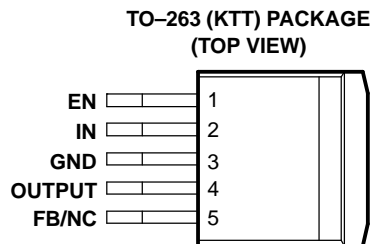
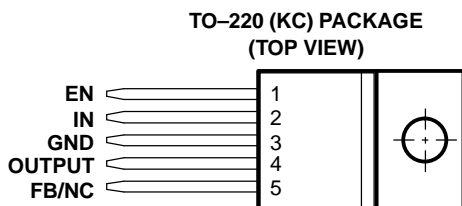

Please be aware that an important notice concerning availability, standard warranty, and use in critical applications of Texas Instruments semiconductor products and disclaimers thereto appears at the end of this data sheet.

PowerPAD is a trademark of Texas Instruments.

Because the PMOS device behaves as a low-value resistor, the dropout voltage is very low (typically 250 mV at an output current of 5 A for the TPS75633) and is directly proportional to the output current. Additionally, since the PMOS pass element is a voltage-driven device, the quiescent current is very low and independent of output loading (typically 125 μ A over the full range of output systems). These two key specifications yield a significant improvement in operating life for battery-powered systems.

The device is enabled when EN (enable) is connected to a high voltage level (> 2 V). Applying a low voltage level (< 0.7 V) to EN shuts down the regulator, reducing the quiescent current to less than 1 μ A at $T_J = 25^\circ\text{C}$.

The TPS756xx is offered in 1.5-V, 1.8-V, 2.5-V, and 3.3-V fixed-voltage versions and in an adjustable version (programmable over the range of 1.22 V to 5 V). Output voltage tolerance is specified as a maximum of 3% over line, load, and temperature ranges. The TPS756xx family is available in a 5-pin TO-220 (KC) and TO-263 (KTT) packages.

AVAILABLE OPTIONS

T_J	OUTPUT VOLTAGE (TYP)	TO-220 (KC)	TO-263(KTT) ⁽¹⁾
-40°C to +125°C	3.3 V	TPS75633KC	TPS75633KTT
	2.5 V	TPS75625KC	TPS75625KTT
	1.8 V	TPS75618KC	TPS75618KTT
	1.5 V	TPS75615KC	TPS75615KTT
	Adjustable 1.22 V to 5 V	TPS75601KC	TPS75601KTT

- (1) The TPS75601 is programmable using an external resistor divider (see application information). Add **T** for KTT devices in 50-piece reel. Add **R** for KTT devices in 500-piece reel.

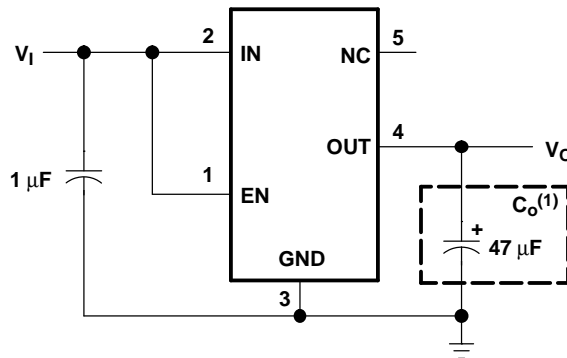

- (1) See application information section for capacitor selection details.

Figure 1. Typical Application Configuration (For Fixed Output Options)

FUNCTIONAL BLOCK DIAGRAM—ADJUSTABLE VERSION

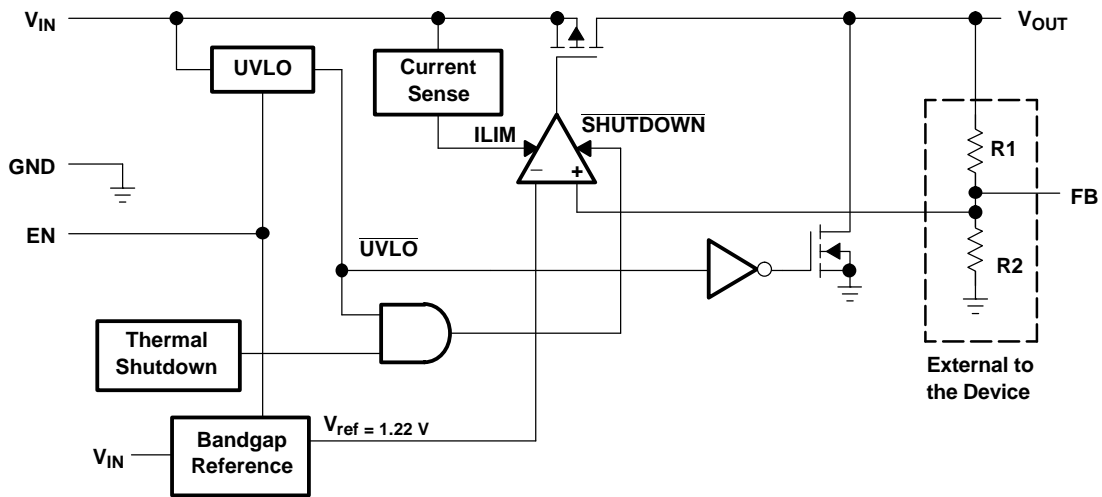

FUNCTIONAL BLOCK DIAGRAM—FIXED VERSION

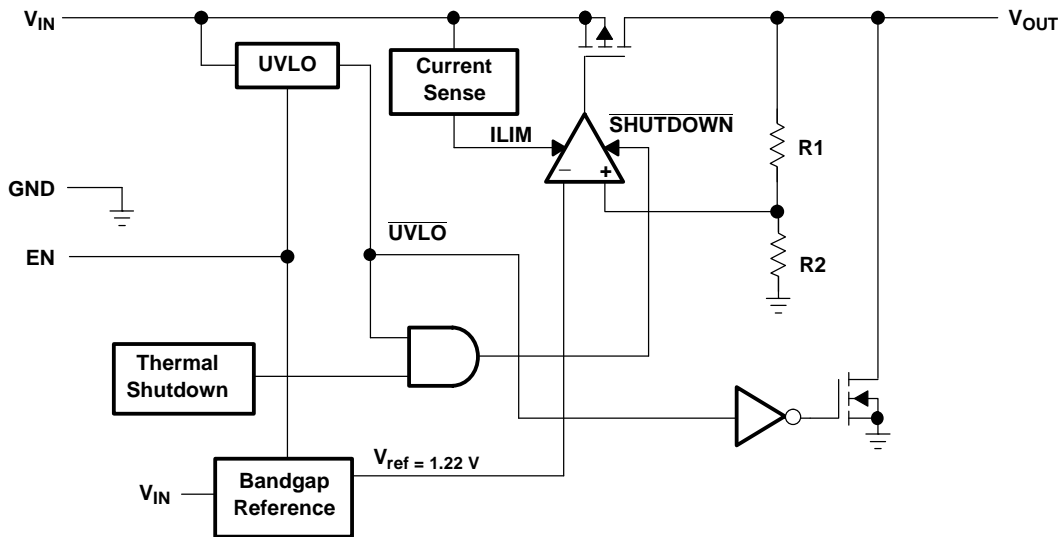

TERMINAL FUNCTIONS (TPS756xx)

TERMINAL NAME	NO.	I/O	DESCRIPTION
EN	1	I	Enable input
FB/NC	5	I	Feedback input voltage for adjustable device/no connection for fixed options
GND	3		Regulator ground
IN	2	I	Input voltage
OUTPUT	4	O	Regulated output voltage

DETAILED DESCRIPTION

The TPS756xx family includes four fixed-output voltage regulators (1.5 V, 1.8 V, 2.5 V, and 3.3 V), and an adjustable regulator, the TPS75601 (adjustable from 1.22 V to 5 V). The bandgap voltage is typically 1.22 V.

Pin Functions

Enable (EN)

The EN terminal is an input which enables or shuts down the device. If EN is a low voltage level (< 0.7 V), the device will be in shutdown or sleep mode. When EN goes to a high voltage level (> 2 V), the device will be enabled.

Feedback (FB)

FB is an input terminal used for the adjustable-output option and must be connected to the output terminal either directly, in order to generate the minimum output voltage of 1.22 V, or through an external feedback resistor divider for other output voltages. The FB connection should be as short as possible. It is essential to route it in such a way to minimize/avoid noise pickup. Adding RC networks between FB terminal and V_O to filter noise is not recommended because it may cause the regulator to oscillate.

Input Voltage (IN)

The V_{IN} terminal is an input to the regulator.

Output Voltage (OUTPUT)

The V_{OUTPUT} terminal is an output from the regulator.

ABSOLUTE MAXIMUM RATINGS

over operating junction temperature range (unless otherwise noted)⁽¹⁾⁽²⁾

	UNIT
Input voltage range, V_I	-0.3 V to 6 V
Voltage range at EN	-0.3 V to 6 V
Peak output current	Internally limited
Continuous total power dissipation	See Dissipation Rating Tables
Output voltage, V_O (OUTPUT, FB)	5.5 V
Operating junction temperature range, T_J	-40°C to 150°C
Storage temperature range, T_{stg}	-65°C to 150°C
ESD rating, HBM	2 kV
ESD rating, CDM	500 V

- (1) Stresses beyond those listed under, "absolute maximum ratings" may cause permanent damage to the device. These are stress ratings only, and functional operation of the device at these or any other conditions beyond those indicated under, "recommended operating conditions" is not implied. Exposure to absolute-maximum-rated conditions for extended periods may affect device reliability.
- (2) All voltage values are with respect to network terminal ground.

DISSIPATION RATING TABLE

package	$R_{\theta JC}$ (°C/W)	$R_{\theta JA}$ (°C/W) ⁽¹⁾
TO-220	2	58.7 ⁽²⁾
TO-263	2	38.7 ⁽³⁾

- (1) For both packages, the $R_{\theta JA}$ values were computed using JEDEC high K board (2S2P) with 1 ounce internal copper plane and ground plane. There was no air flow across the packages.
- (2) $R_{\theta JA}$ was computed assuming a vertical, free standing TO-220 package with pins soldered to the board. There is no heatsink attached to the package.
- (3) $R_{\theta JA}$ was computed assuming a horizontally mounted TO-263 package with pins soldered to the board. There is no copper pad underneath the package.

RECOMMENDED OPERATING CONDITIONS

	MIN	MAX	UNIT
Input voltage, $V_I^{(1)}$	2.8	5.5	V
Output voltage range, V_O	1.22	5	V
Output current, I_O	0	5	A
Operating virtual junction temperature, T_J	-40	125	°C

(1) To calculate the minimum input voltage for your maximum output current, use the following equation: $V_{I(\min)} = V_{O(\max)} + V_{DO(\max \text{ load})}$.

ELECTRICAL CHARACTERISTICS

over recommended operating junction temperature range ($T_J = -40^\circ\text{C}$ to 125°C), $V_I = V_O$ (typ) + 1 V, $I_O = 1$ mA, $EN = V_I$, $C_o = 100$ μF (unless otherwise noted)

PARAMETER	TEST CONDITIONS	MIN	TYP	MAX	UNIT	
Output voltage ⁽¹⁾	Adjustable voltage	$1.22 \text{ V} \leq V_O \leq 5.5 \text{ V}$, $T_J = 25^\circ\text{C}$		V_O	V	
		$1.22 \text{ V} \leq V_O \leq 5.5 \text{ V}$		$0.97 V_O$ $1.03 V_O$		
		$1.22 \text{ V} \leq V_O \leq 5.5 \text{ V}$, $T_J = 0$ to $125^\circ\text{C}^{(2)}$		$0.97 V_O$ $1.03 V_O$		
	1.5 V Output	$T_J = 25^\circ\text{C}$, $2.8 \text{ V} < V_I < 5.5 \text{ V}$		1.5		V
		$2.8 \text{ V} \leq V_I \leq 5.5 \text{ V}$		1.455	1.545	
	1.8 V Output	$T_J = 25^\circ\text{C}$, $2.8 \text{ V} < V_I < 5.5 \text{ V}$		1.8		V
		$2.8 \text{ V} \leq V_I \leq 5.5 \text{ V}$		1.746	1.854	
	2.5 V Output	$T_J = 25^\circ\text{C}$, $3.5 \text{ V} < V_I < 5.5 \text{ V}$		2.5		V
		$3.5 \text{ V} \leq V_I \leq 5.5 \text{ V}$		2.425	2.575	
	3.3 V Output	$T_J = 25^\circ\text{C}$, $4.3 \text{ V} < V_I < 5.5 \text{ V}$		3.3		V
		$4.3 \text{ V} \leq V_I \leq 5.5 \text{ V}$		3.201	3.399	
	Quiescent current (GND current) ^{(1), (3)}	$T_J = 25^\circ\text{C}$		125		μA
		200				
Output voltage line regulation ($\Delta V_O/V_O$) ⁽³⁾	$V_O + 1 \text{ V} \leq V_I \leq 5.5 \text{ V}$, $T_J = 25^\circ\text{C}$		0.04		%V	
	$V_O + 1 \text{ V} \leq V_I < 5.5 \text{ V}$		0.1			
Load regulation ⁽¹⁾			0.35		%V	
Output noise voltage	TPS75615	BW = 300 Hz to 50 kHz, $T_J = 25^\circ\text{C}$, $V_I = 2.8 \text{ V}$		35	μVrms	
Output current limit	$V_O = 0 \text{ V}$		5.5	10	14	A
Thermal shutdown junction temperature			150		°C	
Standby current	EN = 0 $T_J = 25^\circ\text{C}$		0.1		μA	
	EN = 0		10		μA	
FB input current	TPS75601	FB = 1.5 V		-1	1	μA
Power supply ripple rejection	TPS75615	f = 100 Hz, $T_J = 25^\circ\text{C}$, $V_I = 2.8 \text{ V}$, $I_O = 5 \text{ A}$		60		dB
Input current (\overline{EN})	EN = V_I		-1	1		μA
	EN = 0 V		-1	0	1	μA
High level EN input voltage			2		V	
Low level EN input voltage			0.7		V	

(1) $I_O = 1$ mA to 5 A

(2) The adjustable option operates with a 2% tolerance over $T_J = 0$ to 125°C .

(3) If $V_O < 2.5 \text{ V}$ then $V_{I\min} = 2.8 \text{ V}$, $V_{I\max} = 5.5 \text{ V}$:

$$\text{Line regulator (mV)} = (\%V) \times \frac{V_O(V_{I\max} - 2.8V)}{100} \times 1000$$

If $V_O \geq 2.5 \text{ V}$ then $V_{I\min} = V_O + 1 \text{ V}$, $V_{I\max} = 5.5 \text{ V}$:

$$\text{Line regulator (mV)} = (\%V) \times \frac{V_O(V_{I\max} - (V_O + 1V))}{100} \times 1000$$

ELECTRICAL CHARACTERISTICS (continued)

over recommended operating junction temperature range ($T_J = -40^\circ\text{C}$ to 125°C), $V_I = V_O$ (typ) + 1 V, $I_O = 1$ mA, $EN = V_I$, $C_o = 100$ μF (unless otherwise noted)

PARAMETER		TEST CONDITIONS	MIN	TYP	MAX	UNIT
V_O	Dropout voltage, (3.3 V output) ⁽⁴⁾	$I_O = 5$ A, $V_I = 3.2$ V, $T_J = 25^\circ\text{C}$		250		mV
		$I_O = 5$ A, $V_I = 3.2$ V			500	
	Discharge transistor current	$V_O = 1.5$ V, $T_J = 25^\circ\text{C}$	10	25		mA
V_I	UVLO	$T_J = 25^\circ\text{C}$, V_I rising	2.2		2.75	V
	UVLO hysteresis	$T_J = 25^\circ\text{C}$, V_I falling		100		mV

(4) If $V_O < 2.5$ V then $V_{I\text{min}} = 2.8$ V, $V_{I\text{max}} = 5.5$ V:

$$\text{Line regulator (mV)} = (\%V) \times \frac{V_O(V_{I\text{max}} - 2.8\text{V})}{100} \times 1000$$

If $V_O \geq 2.5$ V then $V_{I\text{min}} = V_O + 1$ V, $V_{I\text{max}} = 5.5$ V:

$$\text{Line regulator (mV)} = (\%V) \times \frac{V_O(V_{I\text{max}} - (V_O + 1\text{V}))}{100} \times 1000$$

TYPICAL CHARACTERISTICS

Table of Graphs

			FIGURE
V_O	Output voltage	vs Output current	2, 3
		vs Junction temperature	4, 5
	Ground current	vs Junction temperature	6
	Power supply ripple rejection	vs Frequency	7
	Output spectral noise density	vs Frequency	8
z_o	Output impedance	vs Frequency	9
V_{DO}	Dropout voltage	vs Input voltage	10
		vs Junction temperature	11
V_I	Minimum required input voltage	vs Output voltage	12
	Line transient response		13, 15
	Load transient response		14, 16
V_O	Output voltage and enable voltage	vs Time (start-up)	17
	Equivalent series resistance	vs Output current	19, 20

**TPS75633
 OUTPUT VOLTAGE
 vs
 OUTPUT CURRENT**

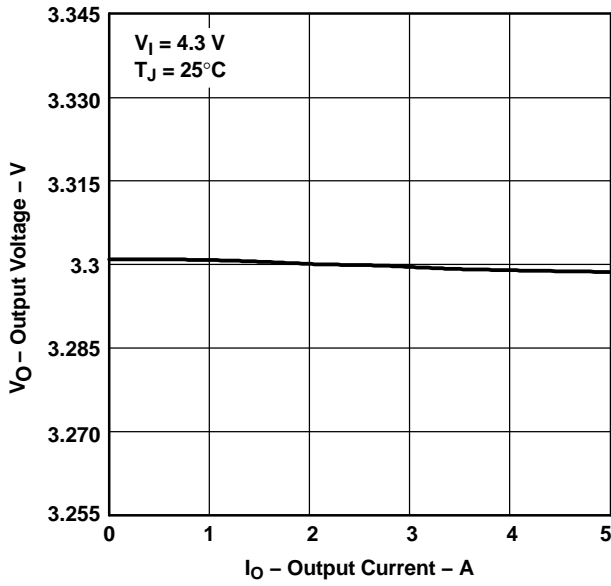

Figure 2.

**TPS75615
 OUTPUT VOLTAGE
 vs
 OUTPUT CURRENT**

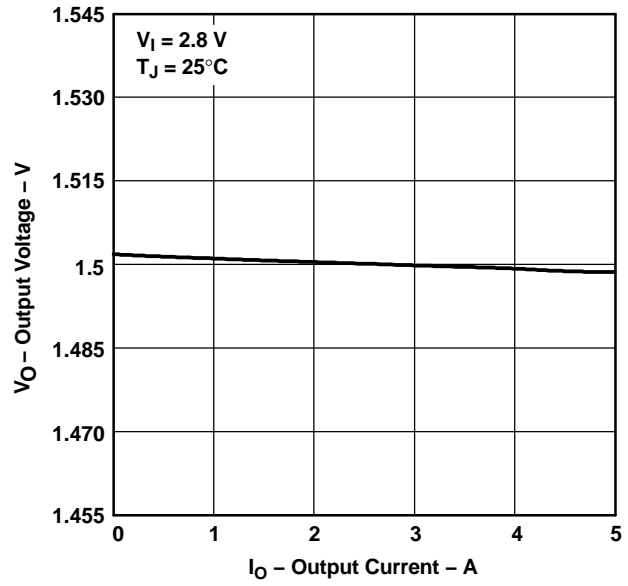

Figure 3.

**TPS75633
 OUTPUT VOLTAGE
 vs
 JUNCTION TEMPERATURE**

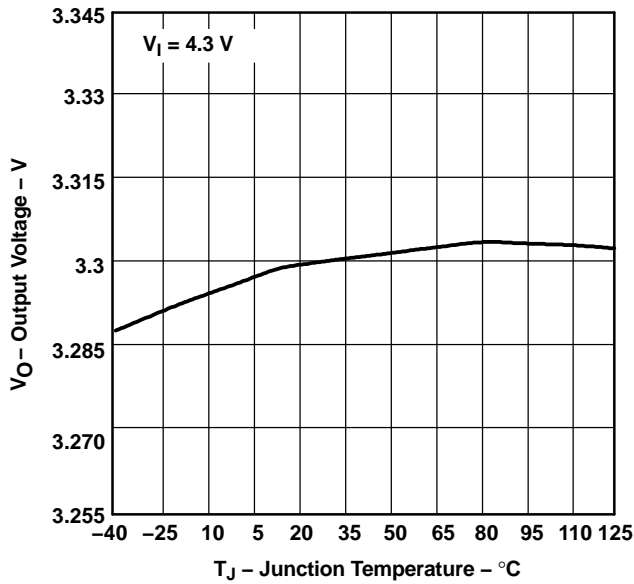

Figure 4.

**TPS75615
 OUTPUT VOLTAGE
 vs
 JUNCTION TEMPERATURE**

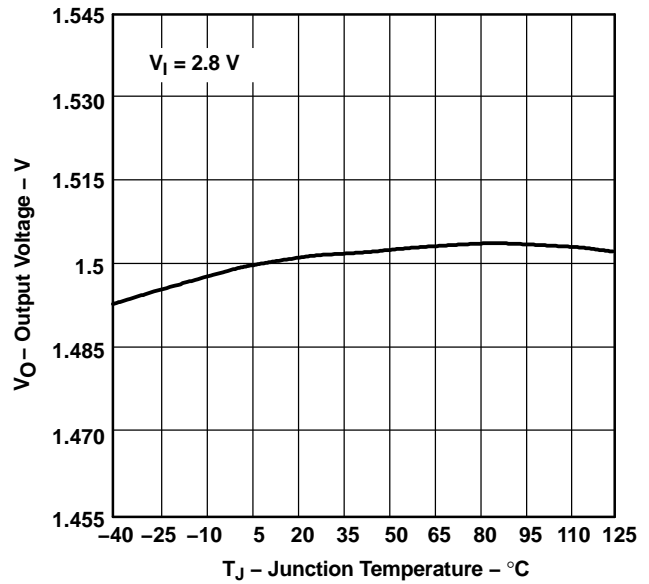

Figure 5.

TYPICAL CHARACTERISTICS (continued)

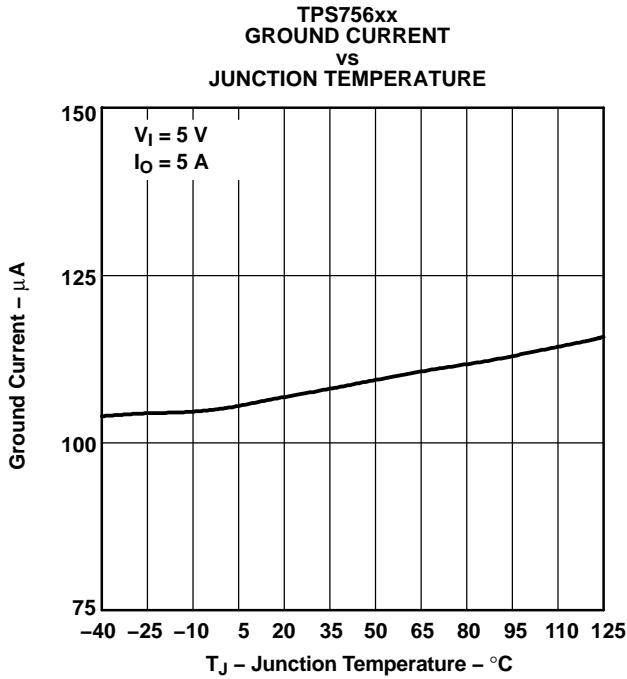

Figure 6.

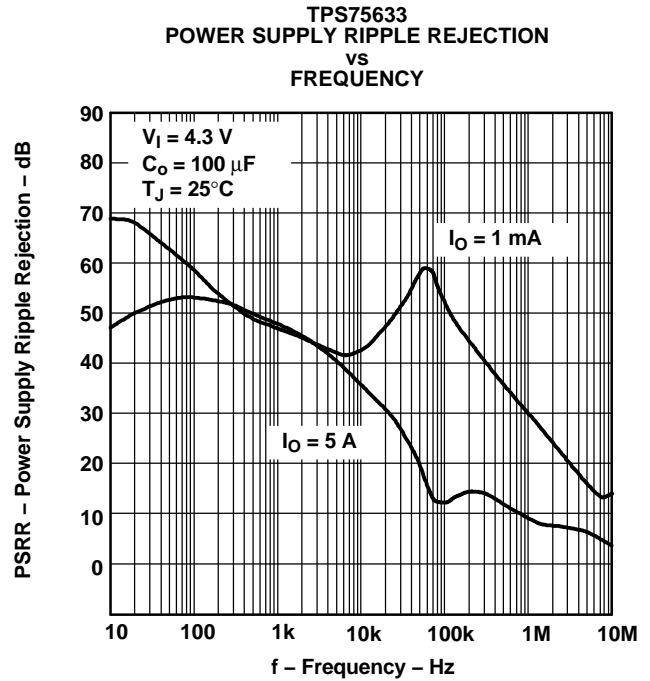

Figure 7.

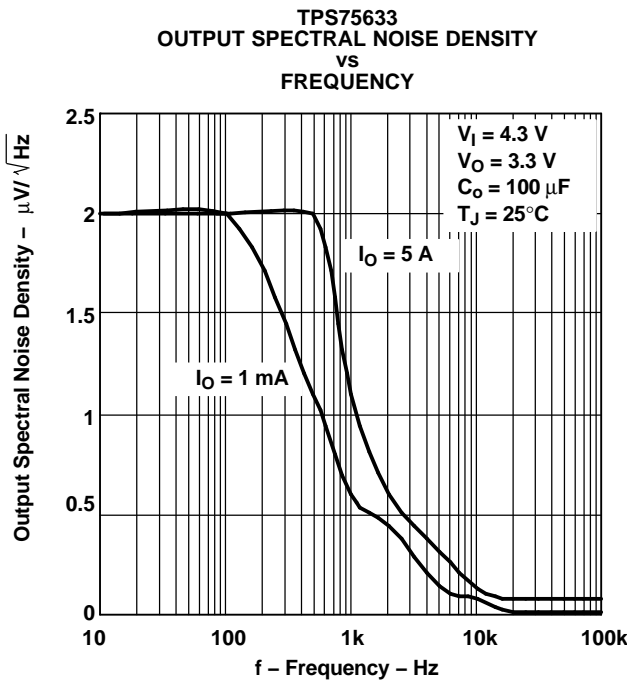

Figure 8.

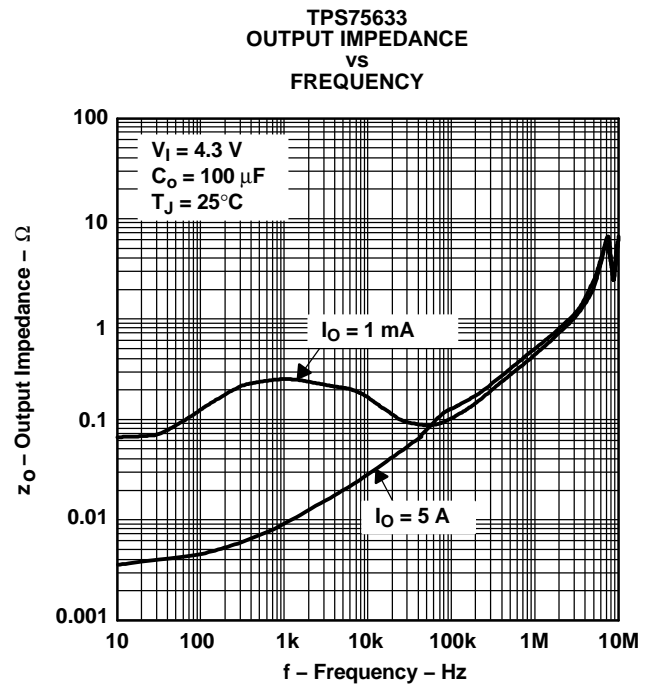

Figure 9.

TYPICAL CHARACTERISTICS (continued)

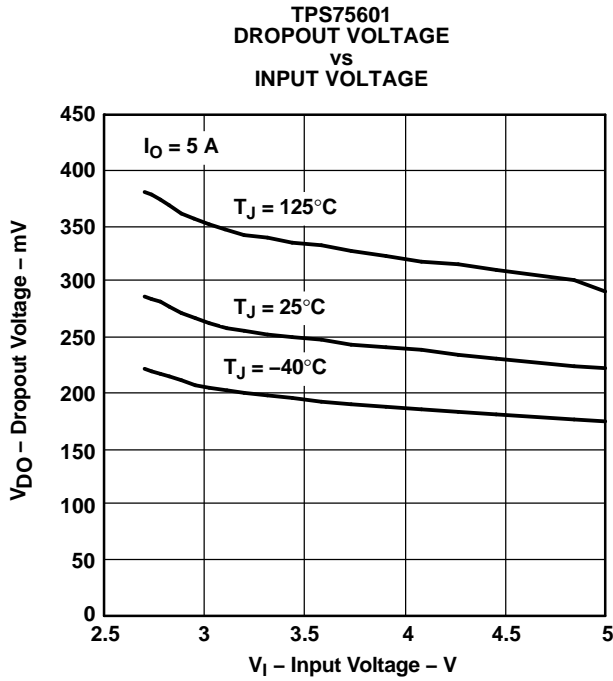

Figure 10.

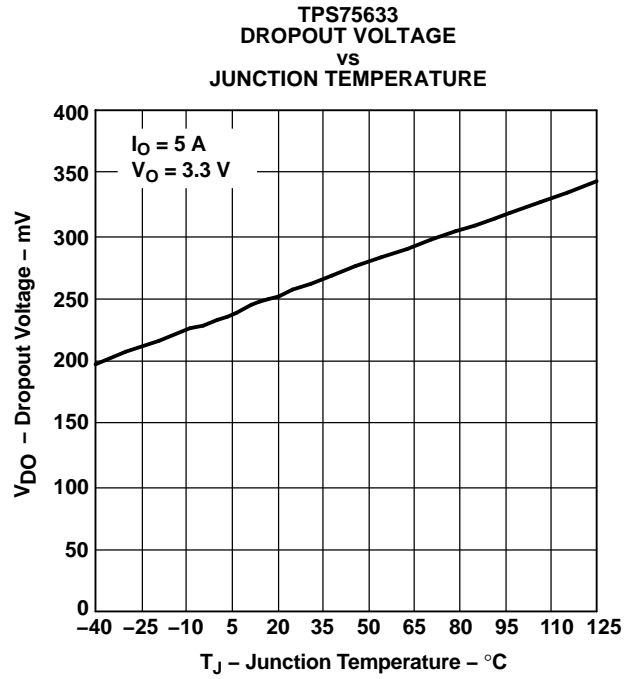

Figure 11.

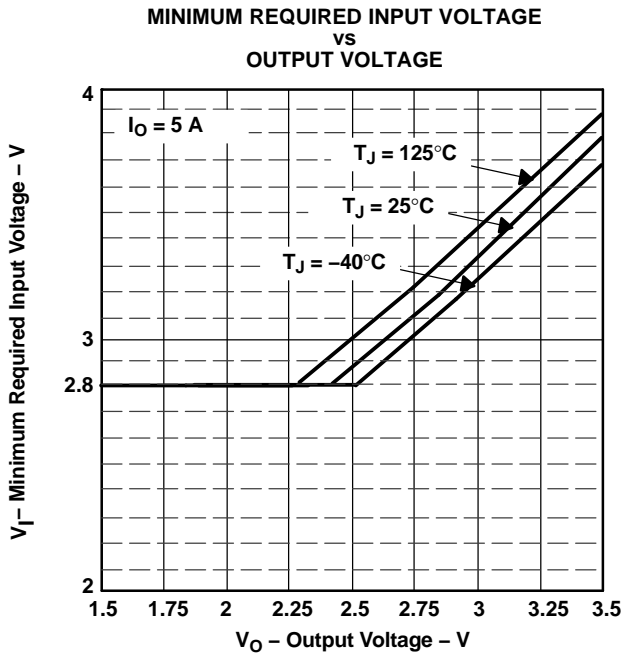

Figure 12.

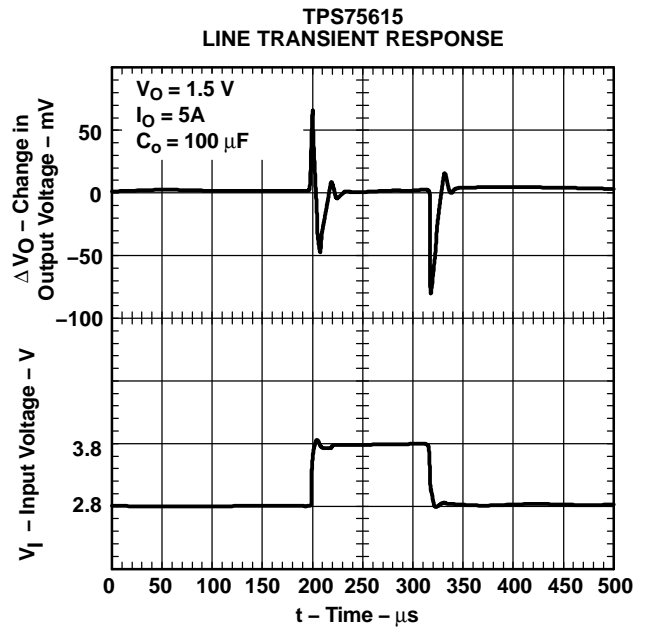

Figure 13.

TYPICAL CHARACTERISTICS (continued)

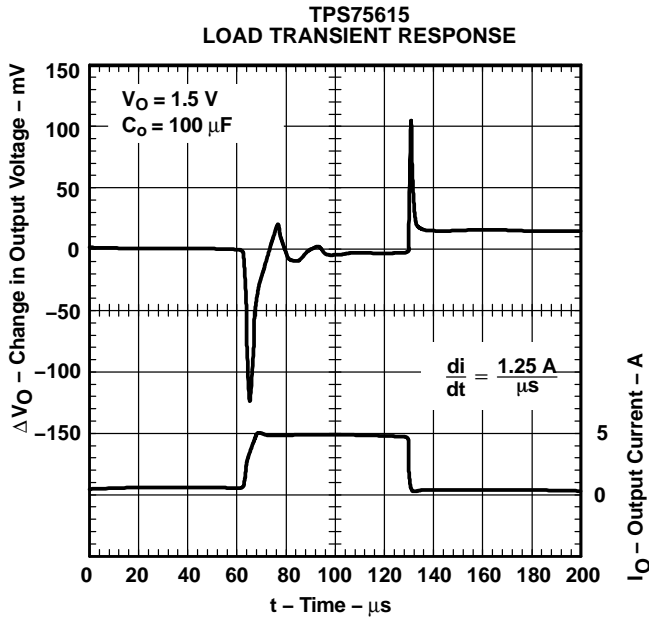

Figure 14.

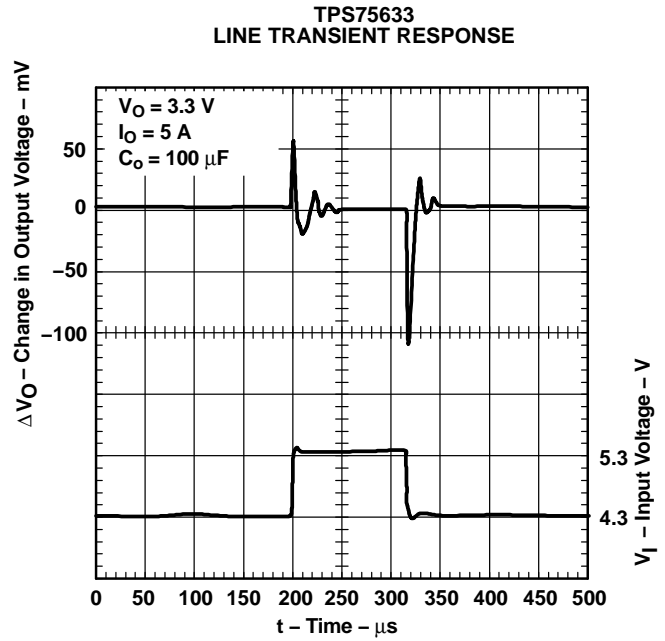

Figure 15.

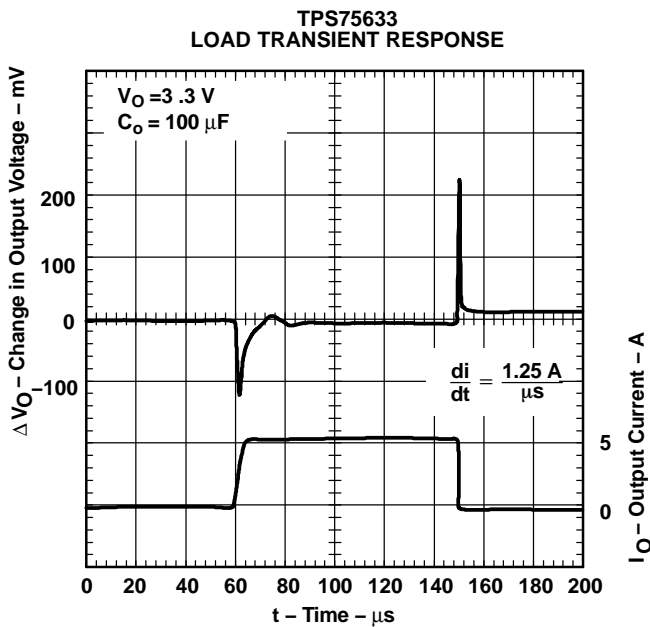

Figure 16.

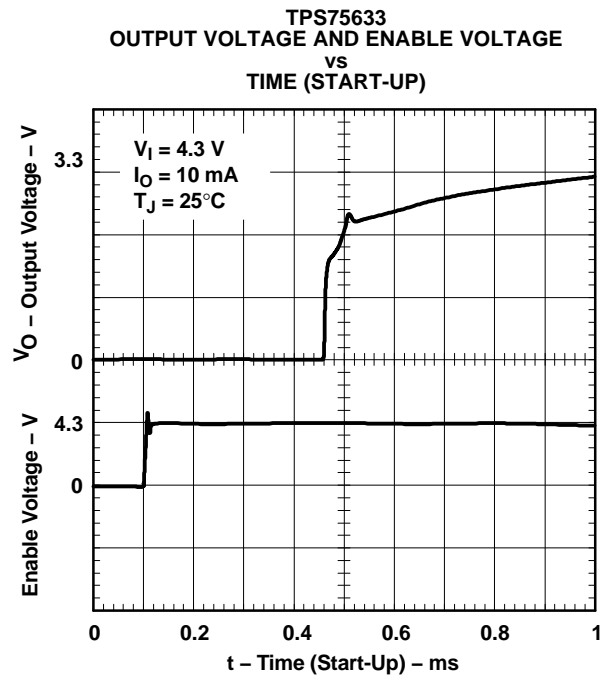

Figure 17.

TYPICAL CHARACTERISTICS (continued)

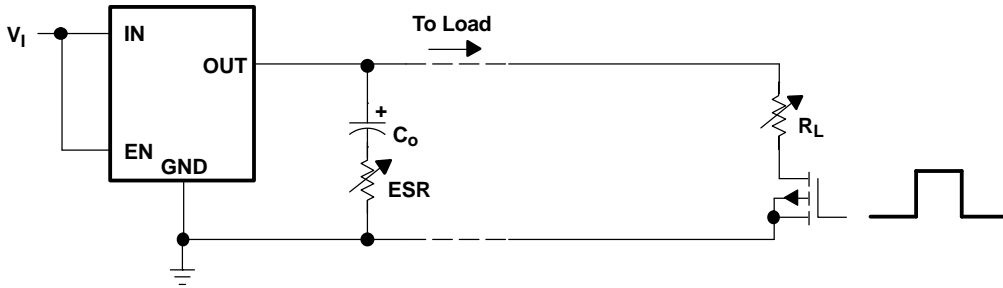

Figure 18. Test Circuit for Typical Regions of Stability (Figures 19 and 20) (Fixed Output Options)

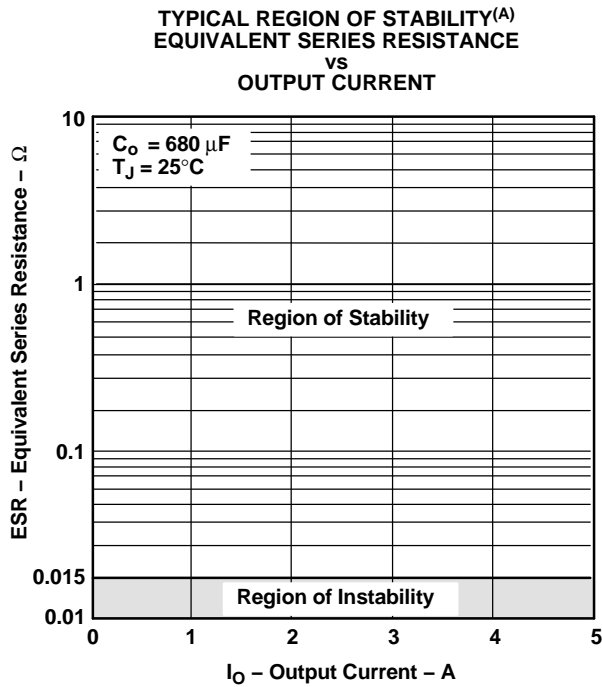

Figure 19.

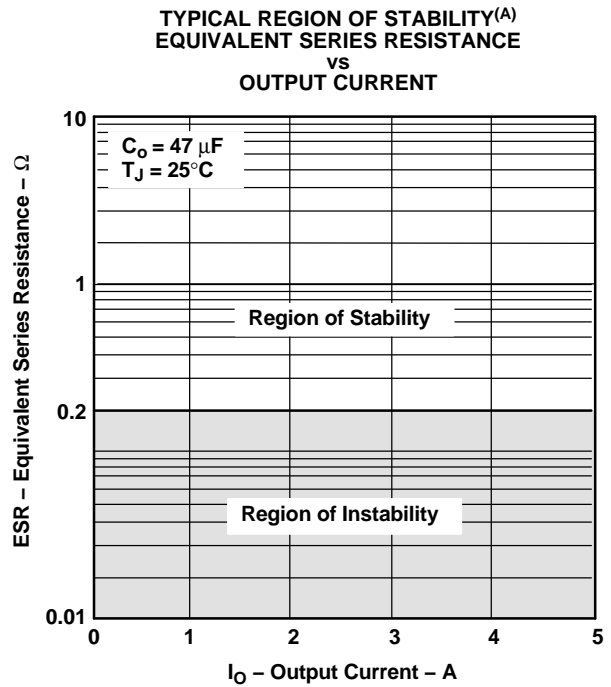

Figure 20.

A. Equivalent series resistance (ESR) refers to the total series resistance, including the ESR of the capacitor, any series resistance added externally, and PWB trace resistance to C_O .

THERMAL INFORMATION

The amount of heat that an LDO linear regulator generates is directly proportional to the amount of power it dissipates during operation. All integrated circuits have a maximum allowable junction temperature ($T_{J,max}$) above which normal operation is not assured. A system designer must design the operating environment so that the operating junction temperature (T_J) does not exceed the maximum junction temperature ($T_{J,max}$). The two main environmental variables that a designer can use to improve thermal performance are air flow and external heatsinks. The purpose of this information is to aid the designer in determining the proper operating environment for a linear regulator that is operating at a specific power level.

In general, the maximum expected power ($P_{D(max)}$) consumed by a linear regulator is computed as:

$$P_{D,max} = (V_{I(avg)} - V_{O(avg)}) \times I_{O(avg)} + V_{I(avg)} \times I_{(Q)} \quad (1)$$

Where:

- $V_{I(avg)}$ is the average input voltage.
- $V_{O(avg)}$ is the average output voltage.
- $I_{O(avg)}$ is the average output current.
- $I_{(Q)}$ is the quiescent current.

For most TI LDO regulators, the quiescent current is insignificant compared to the average output current; therefore, the term $V_{I(avg)} \times I_{(Q)}$ can be neglected. The operating junction temperature is computed by adding the ambient temperature (T_A) and the increase in temperature due to the regulator's power dissipation. The temperature rise is computed by multiplying the maximum expected power dissipation by the sum of the thermal resistances between the junction and the case ($R_{\theta JC}$), the case to heatsink ($R_{\theta CS}$), and the heatsink to ambient ($R_{\theta SA}$). Thermal resistances are measures of how effectively an object dissipates heat. Typically, the larger the device, the more surface area available for power dissipation and the lower the object's thermal resistance.

Figure 21 illustrates these thermal resistances for (a) a TO-220 package attached to a heatsink, and (b) a TO-263 package mounted on a JEDEC High-K board.

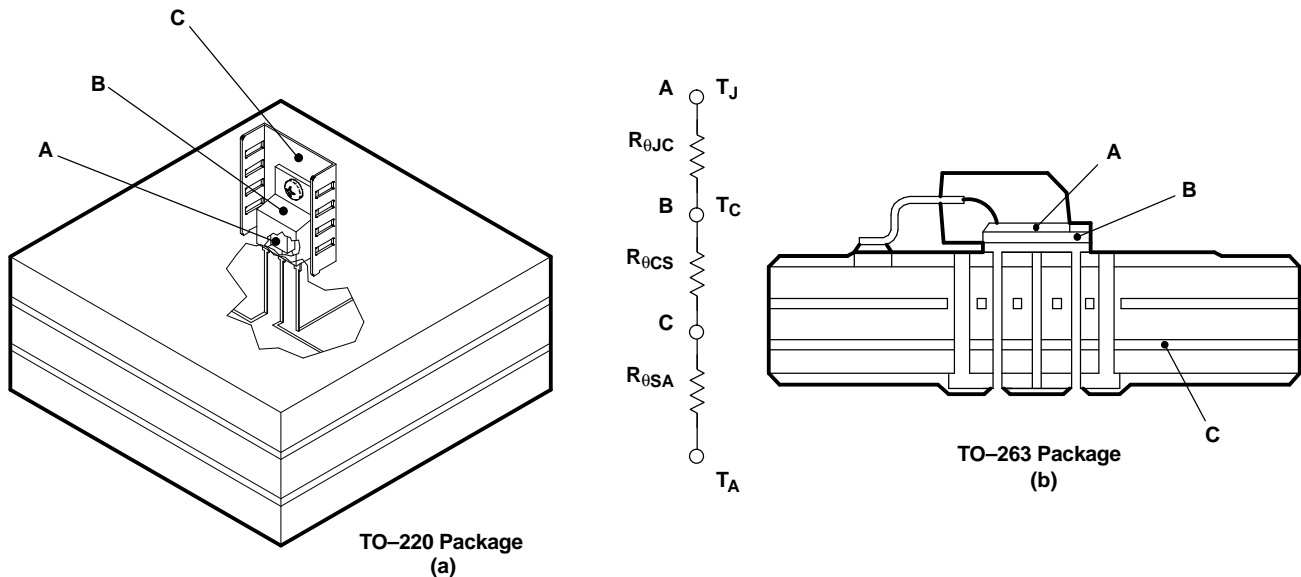

Figure 21. Thermal Resistances

THERMAL INFORMATION (continued)

Equation 2 summarizes the computation:

$$T_J = T_A + P_{Dmax} \times (R_{\theta JC} + R_{\theta CS} + R_{\theta SA}) \quad (2)$$

The $R_{\theta JC}$ is specific to each regulator as determined by its package, lead frame, and die size provided in the regulator's data sheet. The $R_{\theta SA}$ is a function of the type and size of heatsink. For example, *black body radiator* type heatsinks, like the one attached to the TO-220 package in Figure 21(a), can have $R_{\theta CS}$ values ranging from 5 °C/W for very large heatsinks to 50 °C/W for very small heatsinks. The $R_{\theta CS}$ is a function of how the package is attached to the heatsink. For example, if a thermal compound is used to attach a heatsink to a TO-220 package, $R_{\theta CS}$ of 1°C/W is reasonable.

Even if no external *black body radiator* type heatsink is attached to the package, the board on which the regulator is mounted will provide some heatsinking through the pin solder connections. Some packages, like the TO-263 and TI's TSSOP PowerPAD™ packages, use a copper plane underneath the package or the circuit board's ground plane for additional heatsinking to improve their thermal performance. Computer aided thermal modeling can be used to compute very accurate approximations of an integrated circuit's thermal performance in different operating environments (e.g., different types of circuit boards, different types and sizes of heatsinks, different air flows, etc.). Using these models, the three thermal resistances can be combined into one thermal resistance between junction and ambient ($R_{\theta JA}$). This $R_{\theta JA}$ is valid only for the specific operating environment used in the computer model.

Equation 2 simplifies into Equation 3:

$$T_J = T_A + P_{Dmax} \times R_{\theta JA} \quad (3)$$

Rearranging Equation 3 gives Equation 4:

$$R_{\theta JA} = \frac{T_J - T_A}{P_{Dmax}} \quad (4)$$

Using Equation 3 and the computer model generated curves shown in Figure 22 and Figure 25, a designer can quickly compute the required heatsink thermal resistance/board area for a given ambient temperature, power dissipation, and operating environment.

TO-220 Power Dissipation

The TO-220 package provides an effective means of managing power dissipation in through-hole applications. The TO-220 package dimensions are provided in the *Mechanical Data* section at the end of the data sheet. A heatsink can be used with the TO-220 package to effectively lower the junction-to-ambient thermal resistance.

To illustrate, the TPS75625 in a TO-220 package was chosen. For this example, the average input voltage is 3.3 V, the average output voltage is 2.5 V, the average output current is 3 A, the ambient temperature 55°C, the air flow is 150 LFM, and the operating environment is the same as documented below. Neglecting the quiescent current, the maximum average power is:

$$P_{Dmax} = (3.3 - 2.5) \text{ V} \times 3 \text{ A} = 2.4 \text{ W} \quad (5)$$

Substituting T_{Jmax} for T_J into Equation 4 gives Equation 6:

$$R_{\theta JAmax} = (125 - 55)^\circ\text{C} / 2.4 \text{ W} = 29^\circ\text{C/W} \quad (6)$$

From Figure 22, $R_{\theta JA}$ vs Heatsink Thermal Resistance, a heatsink with $R_{\theta SA} = 22^\circ\text{C/W}$ is required to dissipate 2.4 W. The model operating environment used in the computer model to construct Figure 22 consisted of a standard JEDEC High-K board (2S2P) with a 1 oz. internal copper plane and ground plane. Since the package pins were soldered to the board, 450 mm² of the board was modeled as a heatsink. Figure 23 shows the side view of the operating environment used in the computer model.

THERMAL INFORMATION (continued)

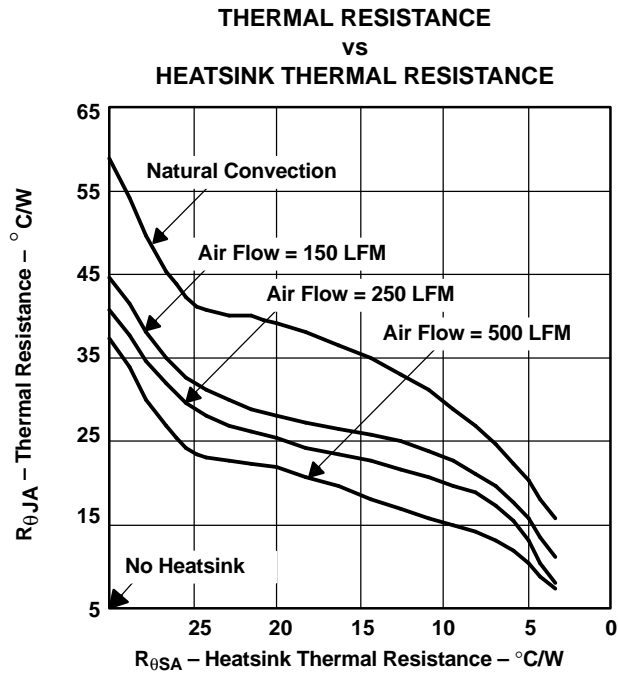

Figure 22.

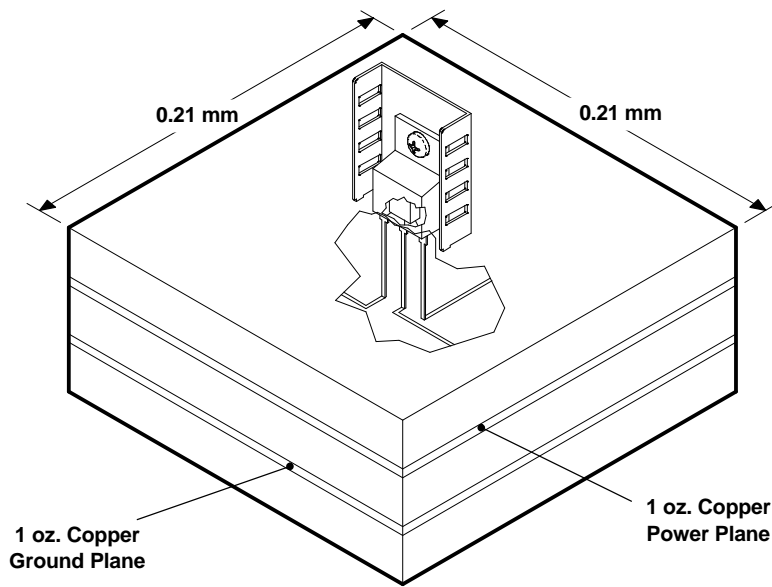

Figure 23.

From the data in Figure 22 and rearranging Equation 4, the maximum power dissipation for a different heatsink $R_{\theta SA}$ and a specific ambient temperature can be computed (see Figure 24).

THERMAL INFORMATION (continued)

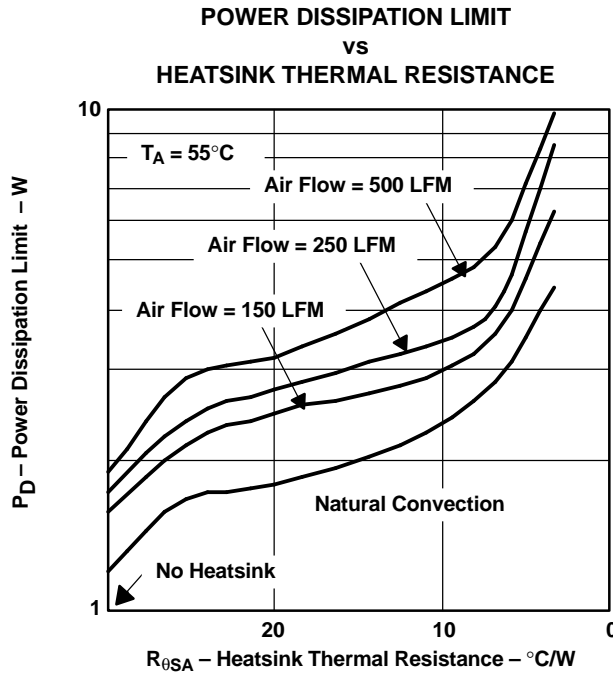

Figure 24.

TO-263 Power Dissipation

The TO-263 package provides an effective means of managing power dissipation in surface-mount applications. The TO-263 package dimensions are provided in the *Mechanical Data* section at the end of the data sheet. The addition of a copper plane directly underneath the TO-263 package enhances the thermal performance of the package.

To illustrate, the TPS75625 in a TO-263 package was chosen. For this example, the average input voltage is 3.3 V, the average output voltage is 2.5 V, the average output current is 3 A, the ambient temperature 55°C, the air flow is 150 LFM, and the operating environment is the same as documented below. Neglecting the quiescent current, the maximum average power is:

$$P_{Dmax} = (3.3 - 2.5) V \times 3 A = 2.4 W \tag{7}$$

Substituting T_{Jmax} for T_J into Equation 4 gives Equation 8:

$$R_{\theta JA} max = (125 - 55)^\circ C / 2.4 W = 29^\circ C/W \tag{8}$$

From Figure 25, R_{θJA} vs Copper Heatsink Area, the ground plane needs to be 2 cm² for the part to dissipate 2.4 W. The model operating environment used in the computer model to construct Figure 25 consisted of a standard JEDEC High-K board (2S2P) with a 1 oz. internal copper plane and ground plane. The package is soldered to a 2 oz. copper pad. The pad is tied through thermal vias to the 1 oz. ground plane. Figure 26 shows the side view of the operating environment used in the computer model.

THERMAL INFORMATION (continued)

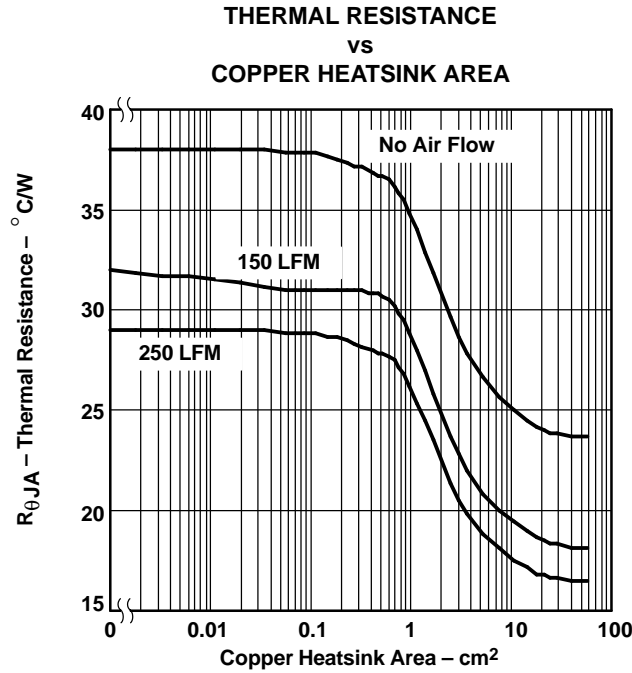

Figure 25.

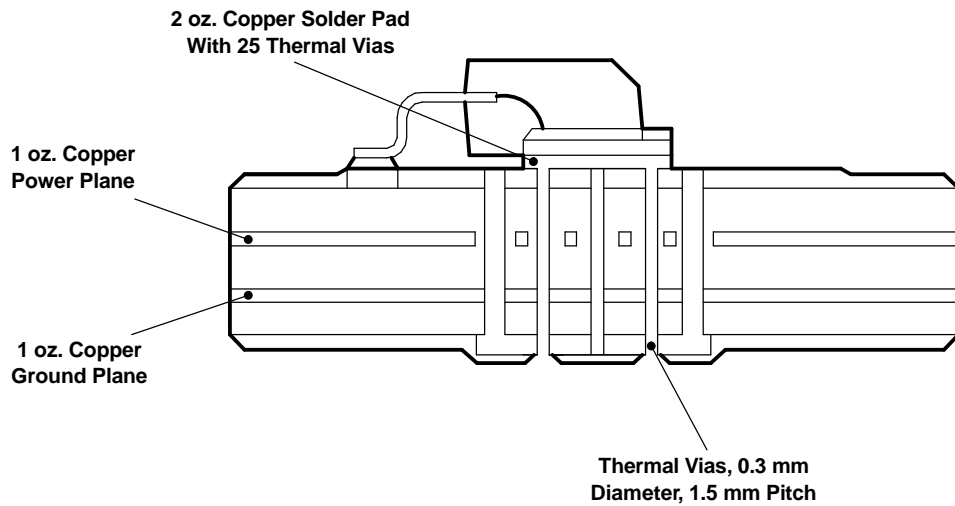

Figure 26.

From the data in Figure 25 and rearranging Equation 4, the maximum power dissipation for a different ground plane area and a specific ambient temperature can be computed (see Figure 27).

THERMAL INFORMATION (continued)

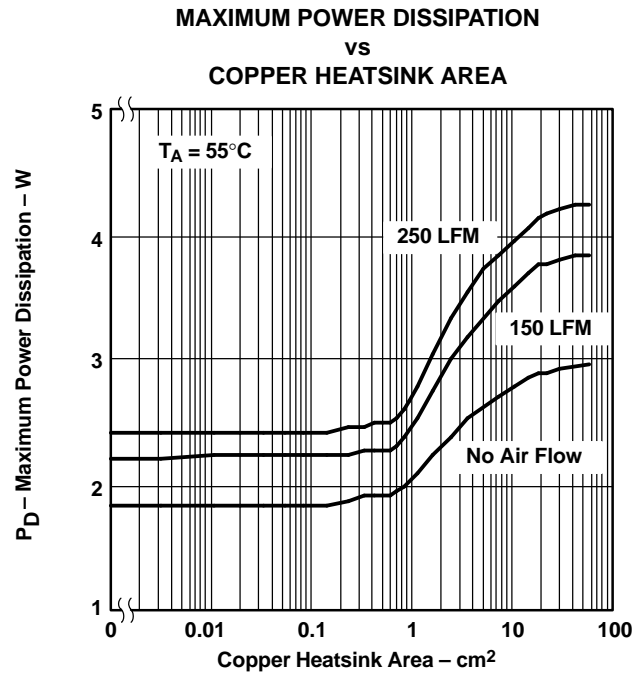

Figure 27.

APPLICATION INFORMATION

The output voltage of the TPS75601 adjustable regulator is programmed using an external resistor divider as shown in Figure 28. The output voltage is calculated using:

$$\text{Line regulator (mV)} = (\%V) \times \frac{V_o(V_{I_{max}} - 2.8V)}{100} \times 1000 \quad (9)$$

Resistors R1 and R2 should be chosen for approximately 40- μ A divider current. Lower value resistors can be used but offer no inherent advantage and waste more power. Higher values should be avoided as leakage currents at FB increase the output voltage error. The recommended design procedure is to choose R2 = 30.1 k Ω to set the divider current at 40 μ A and then calculate R1 using:

$$R1 = \left(\frac{V_o}{V_{ref}} - 1 \right) \times R2 \quad (10)$$

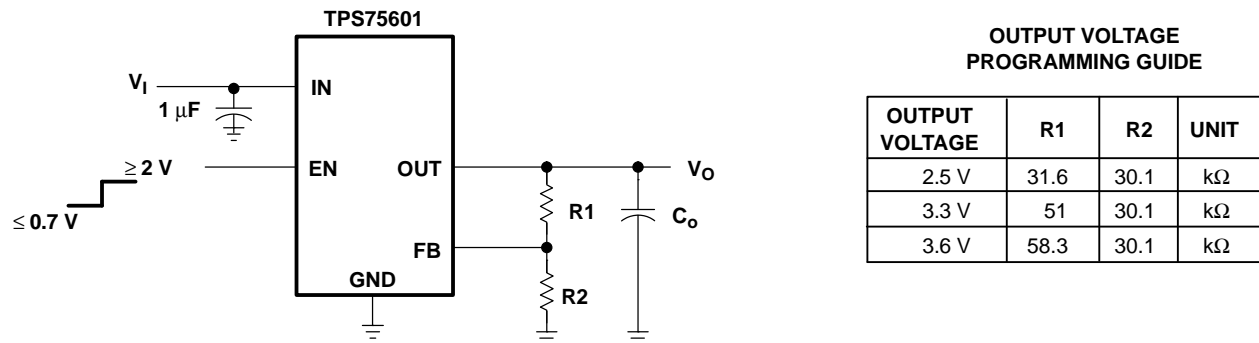

Figure 28. TPS75601 Adjustable LDO Regulator Programming

Regulator Protection

The TPS756xx PMOS-pass transistor has a built-in back diode that conducts reverse currents when the input voltage drops below the output voltage (e.g., during power down). Current is conducted from the output to the input and is not internally limited. When extended reverse voltage is anticipated, external limiting may be appropriate.

The TPS756xx also features internal current limiting and thermal protection. During normal operation, the TPS756xx limits output current to approximately 10 A. When current limiting engages, the output voltage scales back linearly until the overcurrent condition ends. While current limiting is designed to prevent gross device failure, care should be taken not to exceed the power dissipation ratings of the package. If the temperature of the device exceeds 150°C (typ), thermal-protection circuitry shuts it down. Once the device has cooled below 130°C (typ), regulator operation resumes.

Input Capacitor

For a typical application, a ceramic input bypass capacitor (0.22 μ F-1 μ F) is recommended to ensure device stability. This capacitor should be as close as possible to the input pin. Due to the impedance of the input supply, large transient currents will cause the input voltage to droop. If this droop causes the input voltage to drop below the UVLO threshold, the device will turn off. Therefore, it is recommended that a larger capacitor be placed in parallel with the ceramic bypass capacitor at the regulator's input. The size of this capacitor depends on the output current, response time of the main power supply, and the main power supply's distance to the regulator. At a minimum, the capacitor should be sized to ensure that the input voltage does not drop below the minimum UVLO threshold voltage during normal operating conditions.

APPLICATION INFORMATION (continued)

Output Capacitor

As with most LDO regulators, the TPS756xx requires an output capacitor connected between OUT and GND to stabilize the internal control loop. The minimum recommended capacitance value is 47 μF with an ESR (equivalent series resistance) of at least 200 $\text{m}\Omega$. As shown in Figure 29, most capacitor and ESR combinations with a product of $47\text{e-}6 \times 0.2 = 9.4\text{e-}6$ or larger will be stable, provided the capacitor value is at least 47 μF . Solid tantalum electrolytic and aluminum electrolytic capacitors are all suitable, provided they meet the requirements described in this section. Larger capacitors provide a wider range of stability and better load transient response.

This information along with the ESR graphs, Figure 19, Figure 20, and Figure 29, is included to assist in selection of suitable capacitance for the user's application. When necessary to achieve low height requirements along with high output current and/or high load capacitance, several higher ESR capacitors can be used in parallel to meet these guidelines.

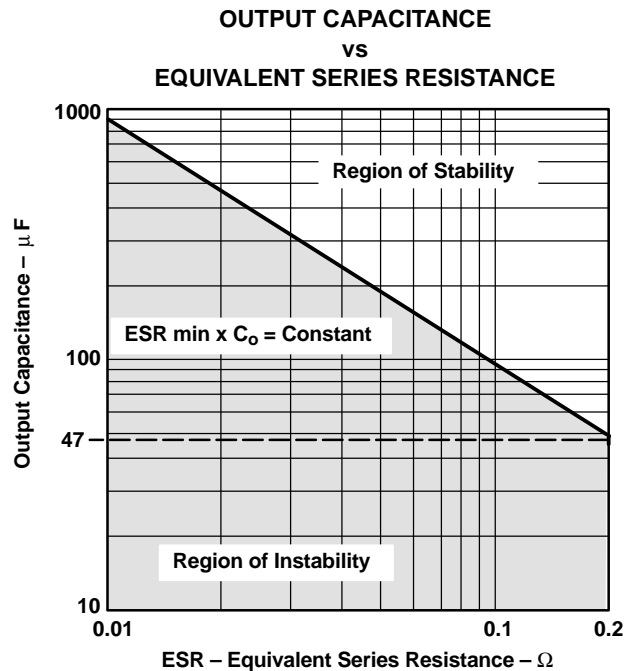

Figure 29.

PACKAGING INFORMATION

ORDERABLE DEVICE	STATUS(1)	PACKAGE TYPE	PACKAGE DRAWING	PINS	PACKAGE QTY
TPS75601KC	ACTIVE	TO/SOT	KC	5	50
TPS75601KTT	OBSOLETE	PFM	KTT	5	
TPS75601KTTR	ACTIVE	PFM	KTT	5	500
TPS75601KTTT	ACTIVE	PFM	KTT	5	50
TPS75615KC	ACTIVE	TO/SOT	KC	5	50
TPS75615KTT	OBSOLETE	PFM	KTT	5	
TPS75615KTTR	ACTIVE	PFM	KTT	5	500
TPS75615KTTT	ACTIVE	PFM	KTT	5	50
TPS75618KC	ACTIVE	TO/SOT	KC	5	50
TPS75618KTT	OBSOLETE	PFM	KTT	5	
TPS75618KTTR	ACTIVE	PFM	KTT	5	500
TPS75618KTTT	ACTIVE	PFM	KTT	5	50
TPS75625KC	ACTIVE	TO/SOT	KC	5	50
TPS75625KTT	OBSOLETE	PFM	KTT	5	
TPS75625KTTR	ACTIVE	PFM	KTT	5	500
TPS75625KTTT	ACTIVE	PFM	KTT	5	50
TPS75633KC	ACTIVE	TO/SOT	KC	5	50
TPS75633KTT	OBSOLETE	PFM	KTT	5	
TPS75633KTTR	ACTIVE	PFM	KTT	5	500
TPS75633KTTT	ACTIVE	PFM	KTT	5	50

(1) The marketing status values are defined as follows:

ACTIVE: Product device recommended for new designs.

LIFEBUY: TI has announced that the device will be discontinued, and a lifetime-buy period is in effect.

NRND: Not recommended for new designs. Device is in production to support existing customers, but TI does not recommend using this part in a new design.

PREVIEW: Device has been announced but is not in production. Samples may or may not be available.

OBSOLETE: TI has discontinued the production of the device.

KTT (R-PSFM-G5)

PLASTIC FLANGE-MOUNT PACKAGE

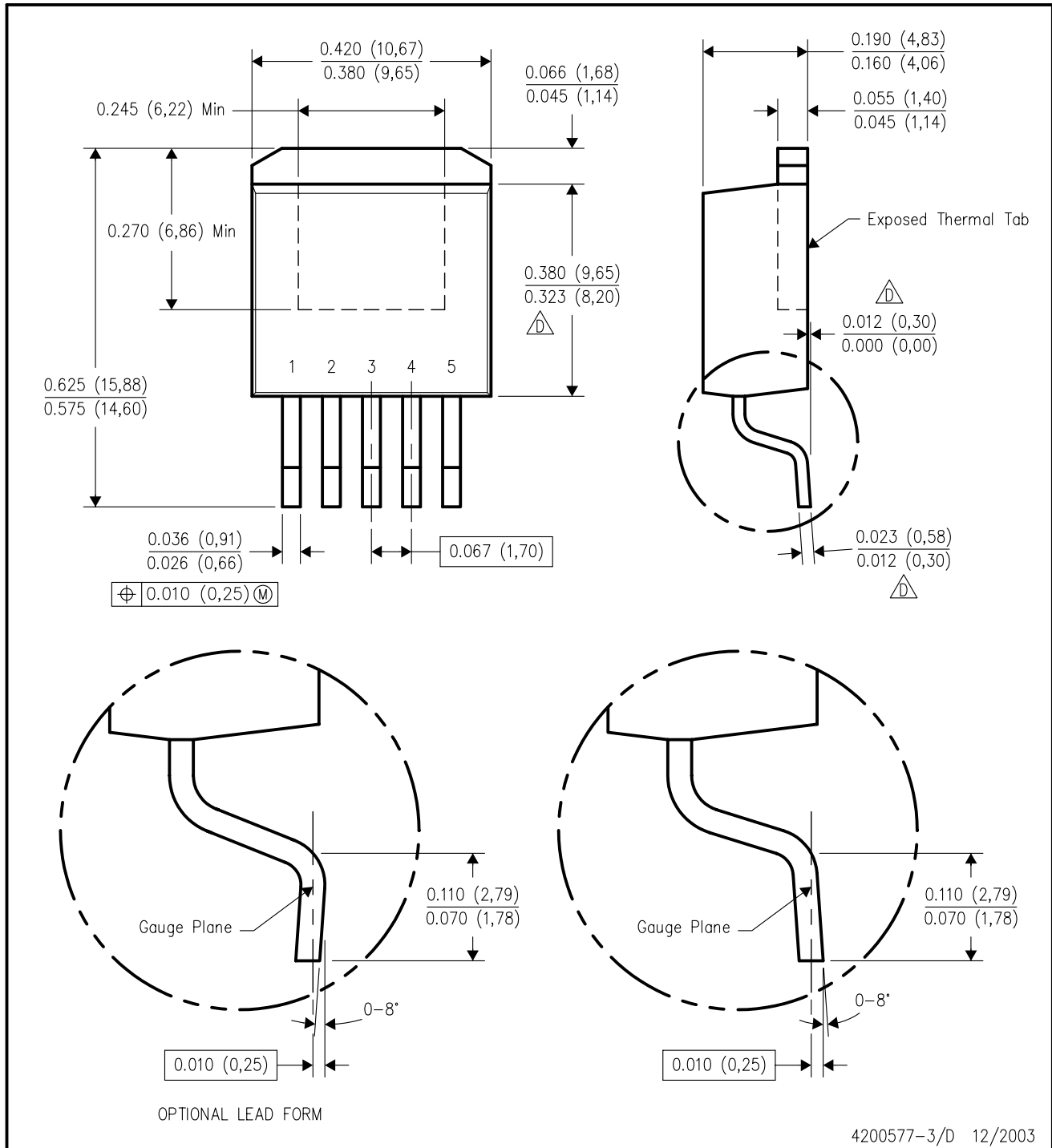

- NOTES:
- A. All linear dimensions are in inches (millimeters).
 - B. This drawing is subject to change without notice.
 - C. Dimensions do not include mold protrusions, not to exceed 0.006 (0,15).
- ⚠ Falls within JEDEC TO-263 variation BA, except minimum lead thickness, maximum seating height, and minimum body length.

KC (R-PSFM-T5)

PLASTIC FLANGE-MOUNT

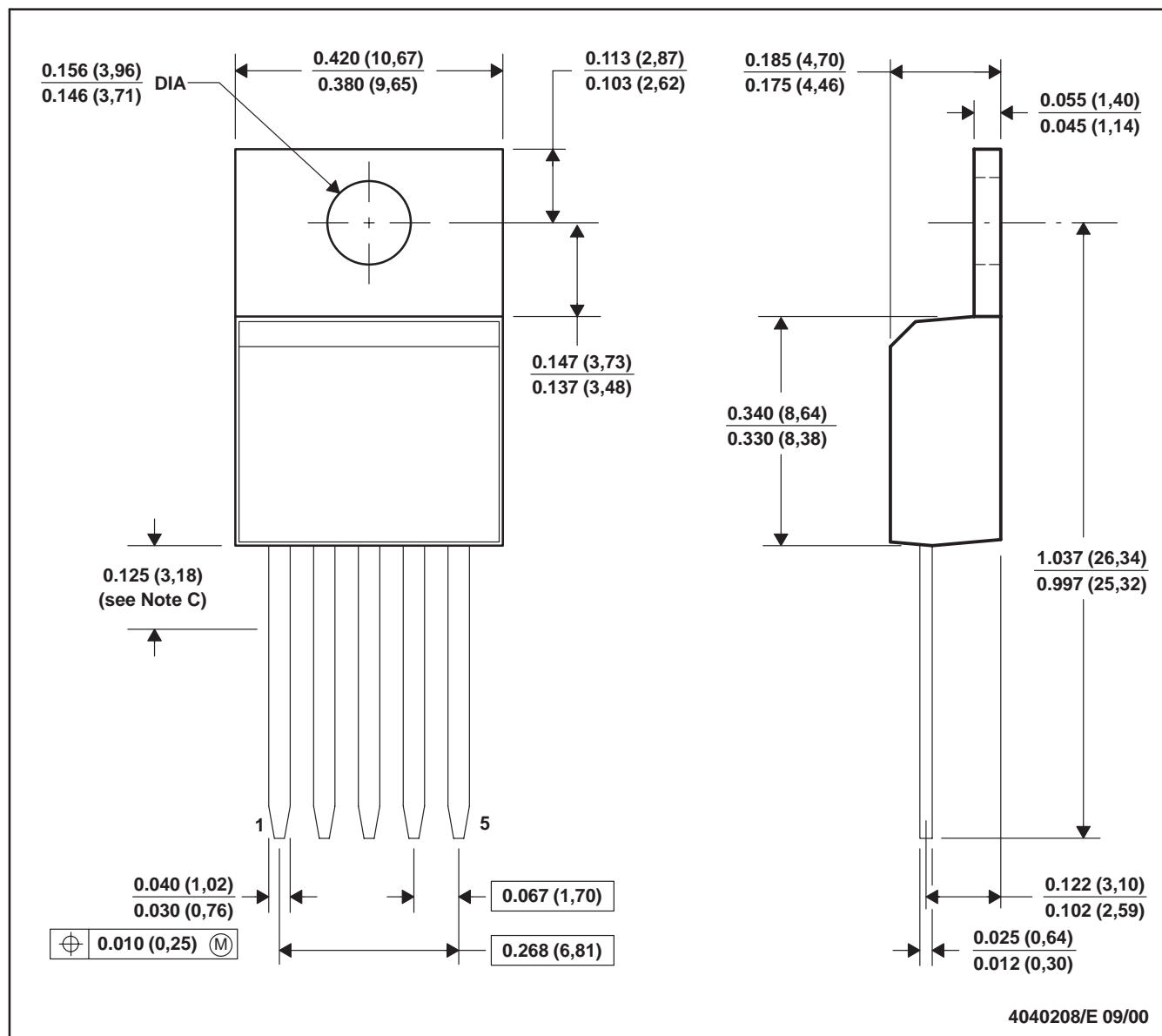

- NOTES: A. All linear dimensions are in inches (millimeters).
 B. This drawing is subject to change without notice.
 C. Lead dimensions are not controlled within this area.
 D. All lead dimensions apply before solder dip.
 E. The center lead is in electrical contact with the mounting tab.

IMPORTANT NOTICE

Texas Instruments Incorporated and its subsidiaries (TI) reserve the right to make corrections, modifications, enhancements, improvements, and other changes to its products and services at any time and to discontinue any product or service without notice. Customers should obtain the latest relevant information before placing orders and should verify that such information is current and complete. All products are sold subject to TI's terms and conditions of sale supplied at the time of order acknowledgment.

TI warrants performance of its hardware products to the specifications applicable at the time of sale in accordance with TI's standard warranty. Testing and other quality control techniques are used to the extent TI deems necessary to support this warranty. Except where mandated by government requirements, testing of all parameters of each product is not necessarily performed.

TI assumes no liability for applications assistance or customer product design. Customers are responsible for their products and applications using TI components. To minimize the risks associated with customer products and applications, customers should provide adequate design and operating safeguards.

TI does not warrant or represent that any license, either express or implied, is granted under any TI patent right, copyright, mask work right, or other TI intellectual property right relating to any combination, machine, or process in which TI products or services are used. Information published by TI regarding third-party products or services does not constitute a license from TI to use such products or services or a warranty or endorsement thereof. Use of such information may require a license from a third party under the patents or other intellectual property of the third party, or a license from TI under the patents or other intellectual property of TI.

Reproduction of information in TI data books or data sheets is permissible only if reproduction is without alteration and is accompanied by all associated warranties, conditions, limitations, and notices. Reproduction of this information with alteration is an unfair and deceptive business practice. TI is not responsible or liable for such altered documentation.

Resale of TI products or services with statements different from or beyond the parameters stated by TI for that product or service voids all express and any implied warranties for the associated TI product or service and is an unfair and deceptive business practice. TI is not responsible or liable for any such statements.

Following are URLs where you can obtain information on other Texas Instruments products and application solutions:

Products		Applications	
Amplifiers	amplifier.ti.com	Audio	www.ti.com/audio
Data Converters	dataconverter.ti.com	Automotive	www.ti.com/automotive
DSP	dsp.ti.com	Broadband	www.ti.com/broadband
Interface	interface.ti.com	Digital Control	www.ti.com/digitalcontrol
Logic	logic.ti.com	Military	www.ti.com/military
Power Mgmt	power.ti.com	Optical Networking	www.ti.com/opticalnetwork
Microcontrollers	microcontroller.ti.com	Security	www.ti.com/security
		Telephony	www.ti.com/telephony
		Video & Imaging	www.ti.com/video
		Wireless	www.ti.com/wireless

Mailing Address: Texas Instruments
Post Office Box 655303 Dallas, Texas 75265

Looking for pricing, stock, or lifecycle information?

Click below to explore more details on WIN SOURCE:

 [View TPS75618KTT on WIN SOURCE](#)

 [Texas Instruments](#) Information

Optimize Your Supply Chain with WIN SOURCE Solutions

-  Global Sourcing Solution
-  Obsolete Management
-  Cost Control Management
-  Shortage Management
-  Alternative Solution
-  Excess Inventory Management