



**THE DATASHEET OF**  
**2N3486**



# 2N2904,A, 2N2905,A, 2N2906,A, 2N2907,A, 2N3485,A, 2N3486,A

JAN, JTX, JTXV AVAILABLE\*

CASE 79-02, STYLE 1  
2N2904/2905 TO-39 (TO-205AD)  
CASE 22-03, STYLE 1  
2N2906/2907 TO-18 (TO-206AA)  
CASE 26-03, STYLE 1  
2N3485/3486 TO-46 (TO-206AB)

GENERAL PURPOSE  
TRANSISTOR

PNP SILICON

## MAXIMUM RATINGS

Rating	Symbol	Non-A Suffix	A-Suffix	Unit	
Collector-Emitter Voltage	$V_{CEO}$	40	60	Vdc	
Collector-Base Voltage	$V_{CBO}$	60		Vdc	
Emitter-Base Voltage	$V_{EBO}$	5.0		Vdc	
Collector Current — Continuous	$I_C$	600		mAdc	
		2N2904,A 2N2905,A	2N2906,A 2N2907,A	2N3485,A 2N3486,A	
Total Device Dissipation @ $T_A = 25^\circ\text{C}$ Derate above $25^\circ\text{C}$	$P_D$	600 3.43	400 2.28	400 2.28	mW mW/ $^\circ\text{C}$
Total Device Dissipation @ $T_C = 25^\circ\text{C}$ Derate above $25^\circ\text{C}$	$P_D$	3.0 17.2	1.8 10.3	2.0 11.43	Watts mW/ $^\circ\text{C}$
Operating and Storage Junction Temperature Range	$T_J, T_{stg}$	-65 to +200		$^\circ\text{C}$	

## ELECTRICAL CHARACTERISTICS ( $T_A = 25^\circ\text{C}$ unless otherwise noted.)

Characteristic	Symbol	Min	Typ	Max	Unit
<b>OFF CHARACTERISTICS</b>					
Collector-Emitter Breakdown Voltage(1) ( $I_C = 10 \text{ mAdc}, I_E = 0$ )	$V_{(BR)CEO}$	40	—	—	Vdc
Non-A Suffix A-Suffix		60	—	—	
Collector-Base Breakdown Voltage ( $I_C = 10 \text{ } \mu\text{Adc}, I_E = 0$ )	$V_{(BR)CBO}$	60	—	—	Vdc
Emitter-Base Breakdown Voltage ( $I_E = 10 \text{ } \mu\text{Adc}, I_C = 0$ )	$V_{(BR)EBO}$	5.0	—	—	Vdc
Collector Cutoff Current ( $V_{CE} = 30 \text{ Vdc}, V_{BE} = 0.5 \text{ Vdc}$ )	$I_{CEX}$	—	—	50	nAdc
Collector Cutoff Current ( $V_{CB} = 50 \text{ Vdc}, I_E = 0$ )	$I_{CBO}$	—	—	0.020	$\mu\text{Adc}$
Non-A Suffix A-Suffix		—	—	0.010	
( $V_{CB} = 50 \text{ Vdc}, I_E = 0, T_A = 150^\circ\text{C}$ )	Non-A Suffix A-Suffix	—	—	20 10	
Base Current ( $V_{CE} = 30 \text{ Vdc}, V_{BE} = 0.5 \text{ Vdc}$ )	$I_B$	—	—	50	nAdc

<b>ON CHARACTERISTICS</b>						
DC Current Gain ( $I_C = 0.1 \text{ mAdc}, V_{CE} = 10 \text{ Vdc}$ )	2N2904, 2N2906, 2N3485 2N2905, 2N2907, 2N3486 2N2904A, 2N2906A, 2N3485A 2N2905A, 2N2907A, 2N3486A	$h_{FE}$	20	—	—	—
(1)			35	—	—	—
			40	—	—	—
			75	—	—	—
( $I_C = 1.0 \text{ mAdc}, V_{CE} = 10 \text{ Vdc}$ )	2N2904, 2N2906, 2N3485 2N2905, 2N2907, 2N3486 2N2904A, 2N2906A, 2N3485A 2N2905A, 2N2907A, 2N3486A	$h_{FE}$	25	—	—	—
(1)			50	—	—	—
			40	—	—	—
			100	—	—	—
( $I_C = 10 \text{ mAdc}, V_{CE} = 10 \text{ Vdc}$ )	2N2904, 2N2906, 2N3485 2N2905, 2N2907, 2N3486 2N2904A, 2N2906A, 2N3485A 2N2905A, 2N2907A, 2N3486A	$h_{FE}$	35	—	—	—
(1)			75	—	—	—
			40	—	—	—
			100	—	—	—
( $I_C = 150 \text{ mAdc}, V_{CE} = 10 \text{ Vdc}$ )(1)	2N2904A, 2N2906A, 2N3485A 2N2905A, 2N2907A, 2N3486A	$h_{FE}$	40	—	120	—
			100	—	300	—

\*ALSO AVAILABLE 2N2905ALJANS AND 2N2907AJANS

**2N2904,A, 2N2905,A, 2N2906,A, 2N2907,A, 2N3485,A, 2N3486,A**

**ELECTRICAL CHARACTERISTICS** (continued) ( $T_A = 25^\circ\text{C}$  unless otherwise noted.)

Characteristic	Symbol	Min	Typ	Max	Unit
$(I_C = 500 \text{ mAdc}, V_{CE} = 10 \text{ Vdc})(1)$ 2N2904, 2N2906, 2N3485 2N2905, 2N2907, 2N3486 2N2904A, 2N2906A, 2N3485A 2N2905A, 2N2907A, 2N3486A		20	—	—	Vdc
		30	—	—	
		40	—	—	
		50	—	—	
Collector-Emitter Saturation Voltage(1) $(I_C = 150 \text{ mAdc}, I_B = 15 \text{ mAdc})$ $(I_C = 500 \text{ mAdc}, I_B = 50 \text{ mAdc})$	$V_{CE(sat)}$	—	—	0.4	Vdc
		—	—	1.6	
Base-Emitter Saturation Voltage $(I_C = 150 \text{ mAdc}, I_B = 15 \text{ mAdc})(1)$ $(I_C = 500 \text{ mAdc}, I_B = 50 \text{ mAdc})$	$V_{BE(sat)}$	—	—	1.3	Vdc
		—	—	2.6	

**SMALL-SIGNAL CHARACTERISTICS**

Current-Gain — Bandwidth Product(2) $(I_C = 50 \text{ mAdc}, V_{CE} = 20 \text{ Vdc}, f = 100 \text{ MHz})$	$f_T$	200	—	—	MHz
Output Capacitance $(V_{CB} = 10 \text{ Vdc}, I_E = 0, f = 100 \text{ kHz})$	$C_{obo}$	—	—	8.0	pF
Input Capacitance $(V_{BE} = 2.0 \text{ Vdc}, I_C = 0, f = 100 \text{ kHz})$	$C_{ibo}$	—	—	30	pF

**SWITCHING CHARACTERISTICS**

Turn-On Time	$(V_{CC} = 30 \text{ Vdc}, I_C = 150 \text{ mAdc}, I_{B1} = 15 \text{ mAdc})$	$t_{on}$	—	26	45	ns
Delay Time		$t_d$	—	6.0	10	ns
Rise Time		$t_r$	—	20	40	ns
Turn-Off Time	$(V_{CC} = 6.0 \text{ Vdc}, I_C = 150 \text{ mAdc}, I_{B1} = I_{B2} = 15 \text{ mAdc})$	$t_{off}$	—	70	100	ns
Storage Time		$t_s$	—	50	80	ns
Fall Time		$t_f$	—	20	30	ns

(1) Pulse Test: Pulse Width  $\leq 300 \mu\text{s}$ , Duty Cycle  $\leq 2.0\%$

(2)  $f_T$  is defined as the frequency at which  $|h_{fe}|$  extrapolates to unity.

**NORMALIZED DC CURRENT GAIN**

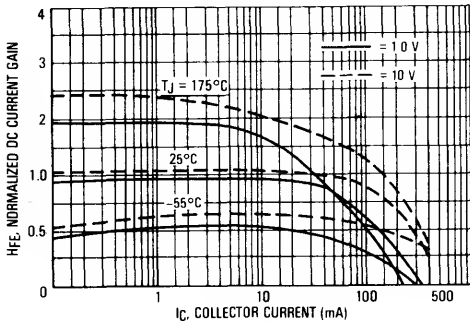

**CURRENT GAIN—BANDWIDTH PRODUCT**

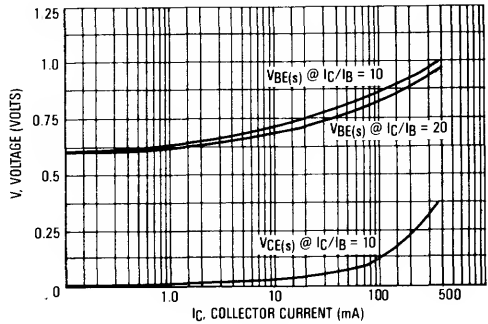

**“ON” VOLTAGES**

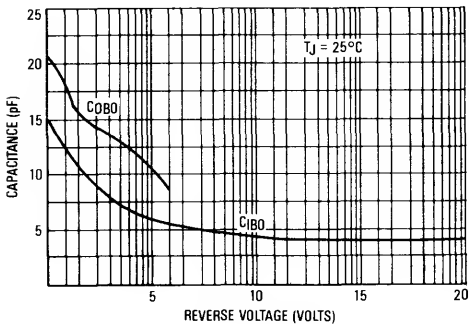

**CURRENT GAIN—BANDWIDTH PRODUCT**

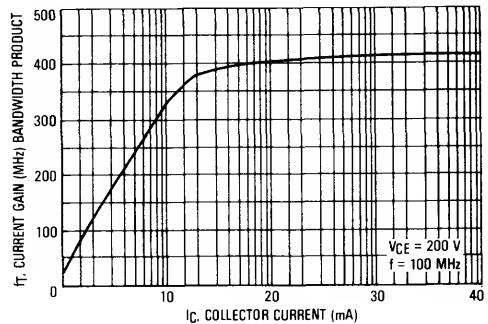

2N2904,A, 2N2905,A, 2N2906,A, 2N2907,A, 2N3485,A, 2N3486,A

CAPACITANCES

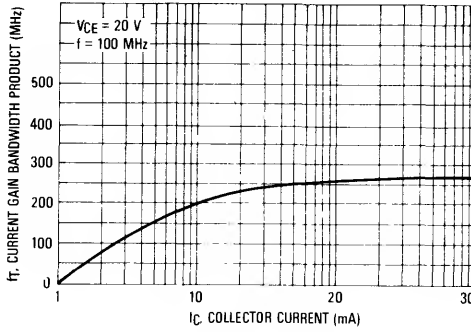

TURN ON BEHAVIOR

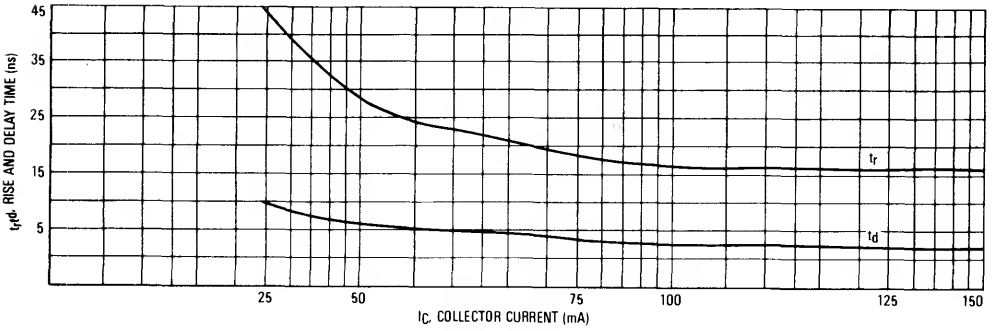

TURN OFF BEHAVIOR

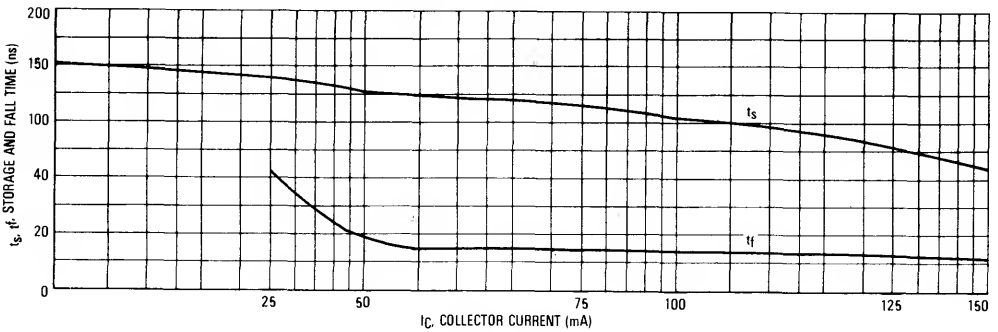

DELAY AND RISE TIME TEST CIRCUIT

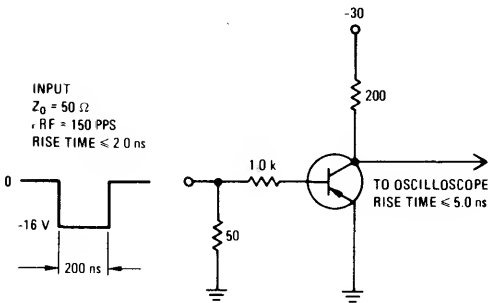

STORAGE AND FALL TIME TEST CIRCUIT

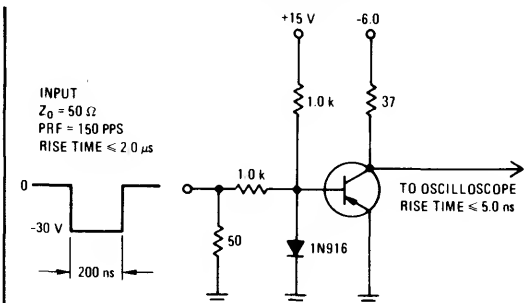

## Looking for pricing, stock, or lifecycle information?

Click below to explore more details on WIN SOURCE:

-  [View 2N3486 on WIN SOURCE](#)
-  [Microchip Technology Information](#)

## Optimize Your Supply Chain with WIN SOURCE Solutions

-  Global Sourcing Solution
-  Obsolete Management
-  Cost Control Management
-  Shortage Management
-  Alternative Solution
-  Excess Inventory Management