



**THE DATASHEET OF  
CY7B9910-2SXC**



## Features

- All Outputs Skew <100 ps typical (250 max.)
- 15 to 80 MHz Output Operation
- Zero Input to Output Delay
- 50% Duty Cycle Outputs
- Outputs drive 50Ω terminated lines
- Low Operating Current
- 24-pin SOIC Package
- Jitter: <200 ps Peak to Peak, <25 ps RMS

## Functional Description

The CY7B9910 and CY7B9920 Low Skew Clock Buffers offer low skew system clock distribution. These multiple output clock drivers optimize the timing of high performance computer systems. Each of the eight individual drivers can drive terminated transmission lines with impedances as low as 50Ω. They deliver minimal and specified output skews and full swing logic levels (CY7B9910 TTL or CY7B9920 CMOS).

The completely integrated PLL enables “zero delay” capability. External divide capability, combined with the internal PLL, allows distribution of a low frequency clock that is multiplied by virtually any factor at the clock destination. This facility minimizes clock distribution difficulty while allowing maximum system clock speed and flexibility.

## Block Diagram Description

### Phase Frequency Detector and Filter

The Phase Frequency Detector and Filter blocks accept inputs from the reference frequency (REF) input and the feedback (FB) input and generate correction information to control the frequency of the Voltage Controlled Oscillator (VCO). These blocks, along with the VCO, form a Phase Locked Loop (PLL) that tracks the incoming REF signal.

### VCO

The VCO accepts analog control inputs from the PLL filter block and generates a frequency. The operational range of the VCO is determined by the FS control pin.

## Logic Block Diagram

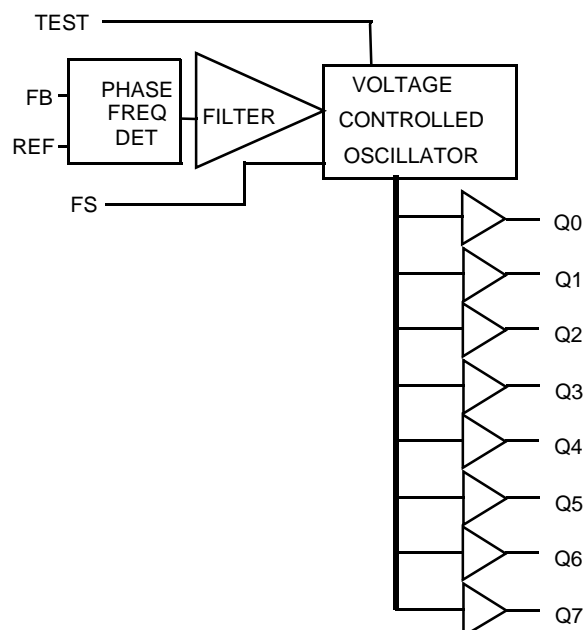

## Pinouts

Figure 1. Pin Configuration – 24-Pin (300-Mil) Molded SOIC S13

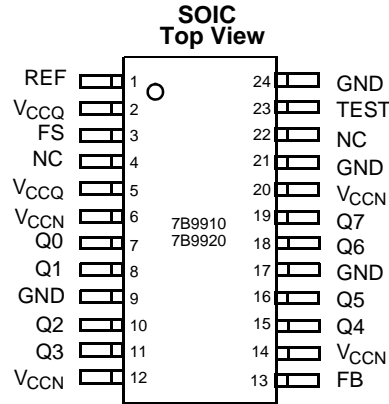

Table 1. Pin Definition

Signal Name	IO	Description
REF	I	Reference frequency input. This input supplies the frequency and timing against which all functional variations are measured.
FB	I	PLL feedback input (typically connected to one of the eight outputs).
FS <sup>[1,2,3]</sup>	I	Three level frequency range select.
TEST	I	Three level select. See <a href="#">TEST MODE</a> .
Q[0..7]	O	Clock outputs.
VCCN	PWR	Power supply for output drivers.
VCCQ	PWR	Power supply for internal circuitry.
GND	PWR	Ground.

## Test Mode

The TEST input is a three level input. In normal system operation, this pin is connected to ground, allowing the CY7B9910 and CY7B9920 to operate as described in [Block Diagram Description](#). For testing purposes, any of the three level inputs can have a removable jumper to ground or be tied LOW through a 100Ω resistor. This enables an external tester to change the state of these pins.

If the TEST input is forced to its MID or HIGH state, the device operates with its internal phase locked loop disconnected and input levels supplied to REF directly control all outputs. Relative output-to-output functions are the same as in normal mode.

### Notes

- For all three state inputs, HIGH indicates a connection to VCC, LOW indicates a connection to GND, and MID indicates an open connection. Internal termination circuitry holds an unconnected input to VCC/2.
- The level to be set on FS is determined by the "normal" operating frequency (fNOM) of the VCO (see [Logic Block Diagram](#)). The frequency appearing at the REF and FB inputs are fNOM when the output connected to FB is undivided. The frequency of the REF and FB inputs are fNOM/X when the device is configured for a frequency multiplication by using external division in the feedback path of value X.
- When the FS pin is selected HIGH, the REF input must not transition upon power up until VCC reached 4.3V.

## Maximum Ratings

Exceeding maximum ratings may shorten the useful life of the device. User guidelines are not tested.

Storage Temperature ..... -65°C to +150°C  
 Ambient Temperature with  
 Power Applied ..... -55°C to +125°C  
 Supply Voltage to Ground Potential..... -0.5V to +7.0V  
 DC Input Voltage ..... -0.5V to +7.0V  
 Output Current into Outputs (LOW) ..... 64 mA  
 Static Discharge Voltage..... >2001V  
 (MIL-STD-883, Method 3015)  
 Latch Up Current ..... >200 mA

## Operating Range

Range	Ambient Temperature	V <sub>CC</sub>
Commercial	0°C to +70°C	5V ± 10%
Industrial	-40°C to +85°C	5V ± 10%

## Electrical Characteristics

Over the Operating Range

Parameter	Description	Test Conditions	CY7B9910		CY7B9920		Unit
			Min	Max	Min	Max	
V <sub>OH</sub>	Output HIGH Voltage	V <sub>CC</sub> = Min, I <sub>OH</sub> = -16 mA	2.4				V
		V <sub>CC</sub> = Min, I <sub>OH</sub> = -40 mA			V <sub>CC</sub> - 0.75		
V <sub>OL</sub>	Output LOW Voltage	V <sub>CC</sub> = Min, I <sub>OL</sub> = 46 mA		0.45			V
		V <sub>CC</sub> = Min, I <sub>OL</sub> = 46 mA				0.45	
V <sub>IH</sub>	Input HIGH Voltage (REF and FB inputs only)		2.0	V <sub>CC</sub>	V <sub>CC</sub> - 1.35	V <sub>CC</sub>	V
V <sub>IL</sub>	Input LOW Voltage (REF and FB inputs only)		-0.5	0.8	-0.5	1.35	V
V <sub>IHH</sub>	Three Level Input HIGH Voltage (Test, FS) <sup>[4]</sup>	Min ≤ V <sub>CC</sub> ≤ Max	V <sub>CC</sub> - 1V	V <sub>CC</sub>	V <sub>CC</sub> - 1V	V <sub>CC</sub>	V
V <sub>IMM</sub>	Three Level Input MID Voltage (Test, FS) <sup>[4]</sup>	Min ≤ V <sub>CC</sub> ≤ Max	V <sub>CC</sub> /2 - 500 mV	V <sub>CC</sub> /2 + 500 mV	V <sub>CC</sub> /2 - 500 mV	V <sub>CC</sub> /2 + 500 mV	V
V <sub>ILL</sub>	Three Level Input LOW Voltage (Test, FS) <sup>[4]</sup>	Min ≤ V <sub>CC</sub> ≤ Max	0.0	1.0	0.0	1.0	V
I <sub>IH</sub>	Input HIGH Leakage Current (REF and FB inputs only)	V <sub>CC</sub> = Max, V <sub>IN</sub> = Max		10		10	μA
I <sub>IL</sub>	Input LOW Leakage Current (REF and FB inputs only)	V <sub>CC</sub> = Max, V <sub>IN</sub> = 0.4V	-500		-500		μA

### Notes

- These inputs are normally wired to VCC, GND, or left unconnected (actual threshold voltages vary as a percentage of VCC). Internal termination resistors hold unconnected inputs at VCC/2. If these inputs are switched, the function and timing of the outputs may glitch and the PLL may require an additional t<sub>LOCK</sub> time before all datasheet limits are achieved.
- Tested one output at a time, output shorted for less than one second, less than 10% duty cycle. Room temperature only. CY7B9920 outputs are not short circuit protected.
- Total output current per output pair is approximated by the following expression that includes device current plus load current:  
 CY7B9910:  
 $ICCN = [(4 + 0.11F) + [(835 - 3F)/Z] + (.0022FC)]N \times 1.1$   
 CY7B9920:  
 $ICCN = [(3.5 + 0.17F) + [(1160 - 2.8F)/Z] + (.0025FC)]N \times 1.1$   
 Where  
 F = frequency in MHz  
 C = capacitive load in pF  
 Z = line impedance in ohms  
 N = number of loaded outputs; 0, 1, or 2  
 FC = F < C.
- Total power dissipation per output pair is approximated by the following expression that includes device power dissipation plus power dissipation due to the load circuit:  
 CY7B9910:  
 $PD = [(22 + 0.61F) + [(1550 - 2.7F)/Z] + (.0125FC)]N \times 1.1$   
 CY7B9920:  
 $PD = [(19.25 + 0.94F) + [(700 + 6F)/Z] + (.017FC)]N \times 1.1$ . See note 3 for variable definition.

## Electrical Characteristics

Over the Operating Range (continued)

Parameter	Description	Test Conditions	CY7B9910		CY7B9920		Unit
			Min	Max	Min	Max	
$I_{IHH}$	Input HIGH Current (Test, FS)	$V_{IN} = V_{CC}$		200		200	$\mu A$
$I_{IMM}$	Input MID Current (Test, FS)	$V_{IN} = V_{CC}/2$	-50	50	-50	50	$\mu A$
$I_{ILL}$	Input LOW Current (Test, FS)	$V_{IN} = GND$		-200		-200	$\mu A$
$I_{OS}$	Output Short Circuit Current <sup>[5]</sup>	$V_{CC} = \text{Max}, V_{OUT} = GND$ (25°C only)		-250		N/A	mA
$I_{CCQ}$	Operating Current Used by Internal Circuitry	$V_{CCN} = V_{CCQ} = \text{Max}$ All Input Selects Open	Com'1	85		85	mA
			Mil/Ind	90		90	
$I_{CCN}$	Output Buffer Current per Output Pair <sup>[6]</sup>	$V_{CCN} = V_{CCQ} = \text{Max}$ $I_{OUT} = 0 \text{ mA}$ Input Selects Open, $f_{MAX}$		14		19	mA
PD	Power Dissipation per Output Pair <sup>[7]</sup>	$V_{CCN} = V_{CCQ} = \text{Max}$ $I_{OUT} = 0 \text{ mA}$ Input Selects Open, $f_{MAX}$		78		104 <sup>[5]</sup>	mW

## Capacitance

Tested initially and after any design or process changes that may affect these parameters.

Parameter	Description	Test Conditions	Max	Unit
$C_{IN}$	Input Capacitance	$T_A = 25^\circ C, f = 1 \text{ MHz}, V_{CC} = 5.0V$	10	pF

**Figure 2. AC Test Loads and Waveforms**

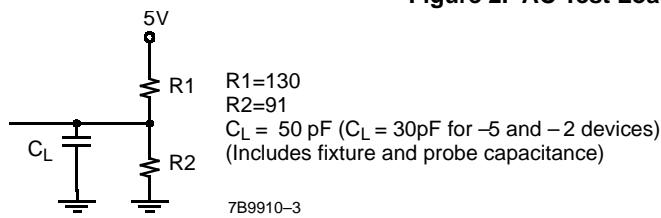

**TTL AC Test Load (CY7B9910)**

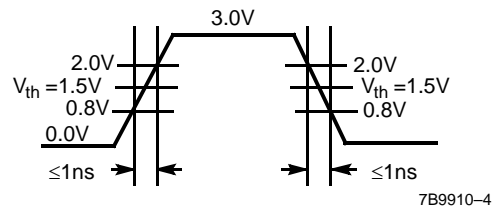

**TTL Input Test Waveform (Cy7B9910)**

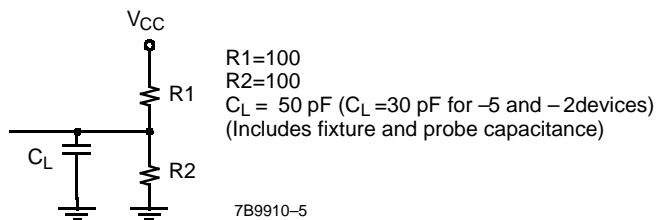

**CMOS AC Test Load (CY7B9920)**

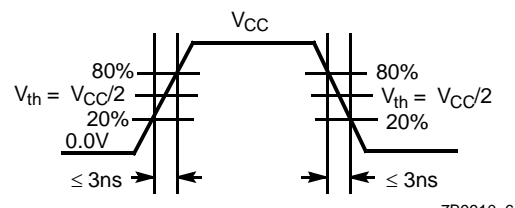

**CMOS Input Test Waveform (CY7B9920)**

## Switching Characteristics

Over the Operating Range <sup>[11]</sup>

Parameter	Description		CY7B9910–2 <sup>[8]</sup>			CY7B9920–2 <sup>[8]</sup>			Unit
			Min	Typ	Max	Min	Typ	Max	
f <sub>NOM</sub>	Operating Clock Frequency in MHz	FS = LOW <sup>[1, 2]</sup>	15		30	15		30	MHz
		FS = MID <sup>[1, 2]</sup>	25		50	25		50	
		FS = HIGH <sup>[1, 2, 3]</sup>	40		80	40		80 <sup>[12]</sup>	
t <sub>RPWH</sub>	REF Pulse Width HIGH		5.0			5.0			ns
t <sub>RPWL</sub>	REF Pulse Width LOW		5.0			5.0			ns
t <sub>SKEW</sub>	Zero Output Skew (All Outputs) <sup>[13, 14]</sup>			0.1	0.25		0.1	0.25	ns
t <sub>DEV</sub>	Device-to-Device Skew <sup>[14, 15]</sup>				0.75			0.75	ns
t <sub>PD</sub>	Propagation Delay, REF Rise to FB Rise		–0.25	0.0	+0.25	–0.25	0.0	+0.25	ns
t <sub>ODCV</sub>	Output Duty Cycle Variation <sup>[16]</sup>		–0.65	0.0	+0.65	–0.65	0.0	+0.65	ns
t <sub>ORISE</sub>	Output Rise Time <sup>[17, 18]</sup>		0.15	1.0	1.2	0.5	2.0	2.5	ns
t <sub>OFALL</sub>	Output Fall Time <sup>[17, 18]</sup>		0.15	1.0	1.2	0.5	2.0	2.5	ns
t <sub>LOCK</sub>	PLL Lock Time <sup>[19]</sup>				0.5			0.5	ms
t <sub>JR</sub>	Cycle-to-Cycle Output Jitter	Peak to Peak			200			200	ps
		RMS			25			25	ps

## Switching Characteristics

Over the Operating Range<sup>[11]</sup> (continued)

Parameter	Description		CY7B9910–5			CY7B9920–5			Unit
			Min	Typ	Max	Min	Typ	Max	
f <sub>NOM</sub>	Operating Clock Frequency in MHz	FS = LOW <sup>[1, 2]</sup>	15		30	15		30	MHz
		FS = MID <sup>[1, 2]</sup>	25		50	25		50	
		FS = HIGH <sup>[1, 2, 3]</sup>	40		80	40		80 <sup>[12]</sup>	
t <sub>RPWH</sub>	REF Pulse Width HIGH		5.0			5.0			ns
t <sub>RPWL</sub>	REF Pulse Width LOW		5.0			5.0			ns
t <sub>SKEW</sub>	Zero Output Skew (All Outputs) <sup>[13, 14]</sup>			0.25	0.5		0.25	0.5	ns
t <sub>DEV</sub>	Device-to-Device Skew <sup>[8, 15]</sup>				1.0			1.0	ns
t <sub>PD</sub>	Propagation Delay, REF Rise to FB Rise		–0.5	0.0	+0.5	–0.5	0.0	+0.5	ns
t <sub>ODCV</sub>	Output Duty Cycle Variation <sup>[16]</sup>		–1.0	0.0	+1.0	–1.0	0.0	+1.0	ns
t <sub>ORISE</sub>	Output Rise Time <sup>[17, 18]</sup>		0.15	1.0	1.5	0.5	2.0	3.0	ns
t <sub>OFALL</sub>	Output Fall Time <sup>[17, 18]</sup>		0.15	1.0	1.5	0.5	2.0	3.0	ns
t <sub>LOCK</sub>	PLL Lock Time <sup>[19]</sup>				0.5			0.5	ms
t <sub>JR</sub>	Cycle-to-Cycle Output Jitter	Peak to Peak <sup>[8]</sup>			200			200	ps
		RMS <sup>[8]</sup>			25			25	ps

### Notes

8. Guaranteed by statistical correlation. Tested initially and after any design or process changes that may affect these parameters.
9. CMOS output buffer current and power dissipation specified at 50 MHz reference frequency.
10. Applies to REF and FB inputs only.
11. Test measurement levels for the CY7B9910 are TTL levels (1.5V to 1.5V). Test measurement levels for the CY7B9920 are CMOS levels (VCC/2 to VCC/2). Test conditions assume signal transition times of 2 ns or less and output loading as shown in the AC Test Loads and Waveforms unless otherwise specified.
12. Except as noted, all CY7B9920–2 and –5 timing parameters are specified to 80 MHz with a 30 pF load.
13. tSKEW is defined as the time between the earliest and the latest output transition among all outputs when all are loaded with 50 pF and terminated with 50Ω to 2.06V (CY7B9910) or VCC/2 (CY7B9920).
14. tSKEW is defined as the skew between outputs.
15. tDEV is the output-to-output skew between any two outputs on separate devices operating under the same conditions (VCC, ambient temperature, air flow, and so on).
16. tODCV is the deviation of the output from a 50% duty cycle.
17. Specified with outputs loaded with 30 pF for the CY7B99X0–2 and –5 devices and 50 pF for the CY7B99X0–7 devices. Devices are terminated through 50Ω to 2.06V (CY7B9910) or VCC/2 (CY7B9920).
18. tORISE and tOFALL measured between 0.8V and 2.0V for the CY7B9910 or 0.8VCC and 0.2VCC for the CY7B9920.
19. tLOCK is the time that is required before synchronization is achieved. This specification is valid only after VCC is stable and within normal operating limits. This parameter is measured from the application of a new signal or frequency at REF or FB until tPD is within specified limits.

## Switching Characteristics

Over the Operating Range<sup>[11]</sup> (continued)

Parameter	Description		CY7B9910-7			CY7B9920-7			Unit
			Min	Typ	Max	Min	Typ	Max	
f <sub>NOM</sub>	Operating Clock Frequency in MHz	FS = LOW <sup>[1, 2]</sup>	15		30	15		30	MHz
		FS = MID <sup>[1, 2]</sup>	25		50	25		50	
		FS = HIGH <sup>[1, 2, 3]</sup>	40		80	40		80 <sup>[12]</sup>	
t <sub>RPWH</sub>	REF Pulse Width HIGH		5.0			5.0			ns
t <sub>RPWL</sub>	REF Pulse Width LOW		5.0			5.0			ns
t <sub>SKEW</sub>	Zero Output Skew (All Outputs) <sup>[13, 14]</sup>			0.3	0.75		0.3	0.75	ns
t <sub>DEV</sub>	Device-to-Device Skew <sup>[8, 15]</sup>				1.5			1.5	ns
t <sub>PD</sub>	Propagation Delay, REF Rise to FB Rise		-0.7	0.0	+0.7	-0.7	0.0	+0.7	ns
t <sub>ODCV</sub>	Output Duty Cycle Variation <sup>[16]</sup>		-1.2	0.0	+1.2	-1.2	0.0	+1.2	ns
t <sub>ORISE</sub>	Output Rise Time <sup>[17, 18]</sup>		0.15	1.5	2.5	0.5	3.0	5.0	ns
t <sub>OFALL</sub>	Output Fall Time <sup>[17, 18]</sup>		0.15	1.5	2.5	0.5	3.0	5.0	ns
t <sub>LOCK</sub>	PLL Lock Time <sup>[19]</sup>				0.5			0.5	ms
t <sub>JR</sub>	Cycle-to-Cycle Output Jitter	Peak to Peak <sup>[8]</sup>			200			200	ps
t <sub>JR</sub>		RMS <sup>[8]</sup>			25			25	ps

## AC Timing Diagrams

Figure 3. AC Timing Diagrams

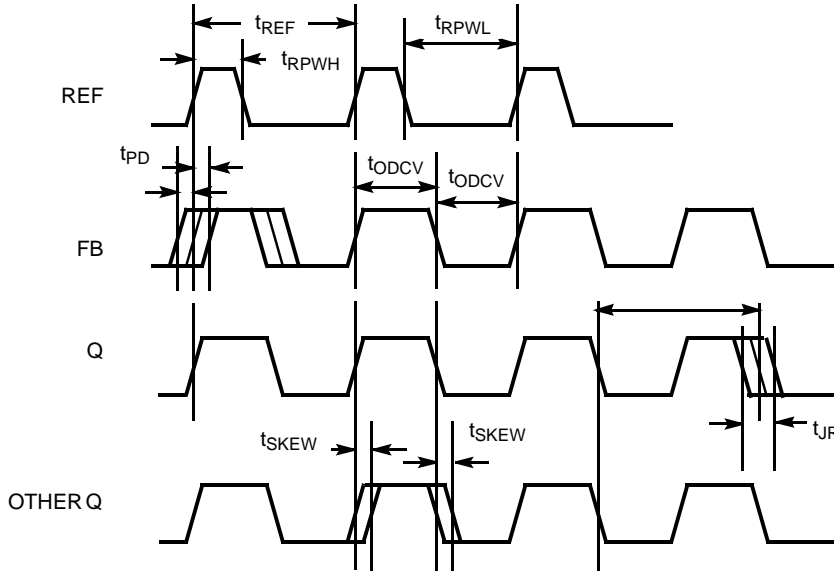
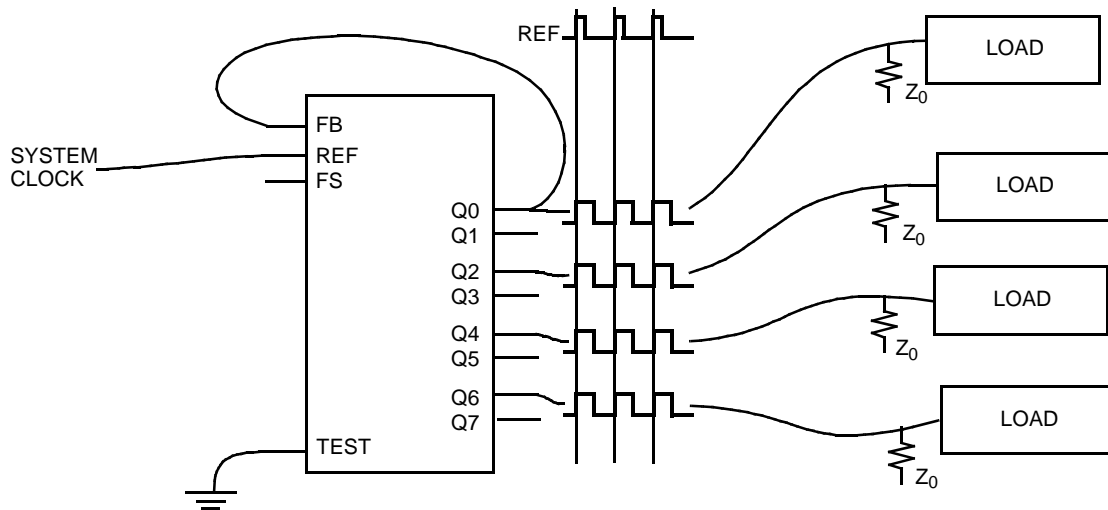

Figure 4. Zero Skew and Zero Delay Clock Driver





### Ordering Information

Accuracy (ps)	Ordering Code	Package Type	Operating Range
500	CY7B9920-5SC <sup>[20]</sup>	24-Pin Small Outline IC	Commercial
	CY7B9920-5SCT <sup>[20]</sup>	24-Pin Small Outline IC - Tape and Reel	Commercial
	CY7B9920-5S <sup>[20]</sup>	24-Pin Small Outline IC	Industrial
<b>Pb-free</b>			
250	CY7B9910-2SXC	24-Pin Small Outline IC	Commercial
	CY7B9910-2SXCT	24-Pin Small Outline IC - Tape and Reel	Commercial
500	CY7B9910-5SXC	24-Pin Small Outline IC	Commercial
	CY7B9910-5SXCT	24-Pin Small Outline IC - Tape and Reel	Commercial
	CY7B9910-5SXI	24-Pin Small Outline IC	Industrial
	CY7B9910-5SXIT	24-Pin Small Outline IC - Tape and Reel	Industrial
	CY7B9910-7SXC	24-Pin Small Outline IC	Commercial
750	CY7B9910-7SXC	24-Pin Small Outline IC	Commercial
	CY7B9910-7SXCT	24-Pin Small Outline IC - Tape and Reel	Commercial

### Package Diagram

Figure 6. 24-Pin (300-Mil) Molded SOIC S13

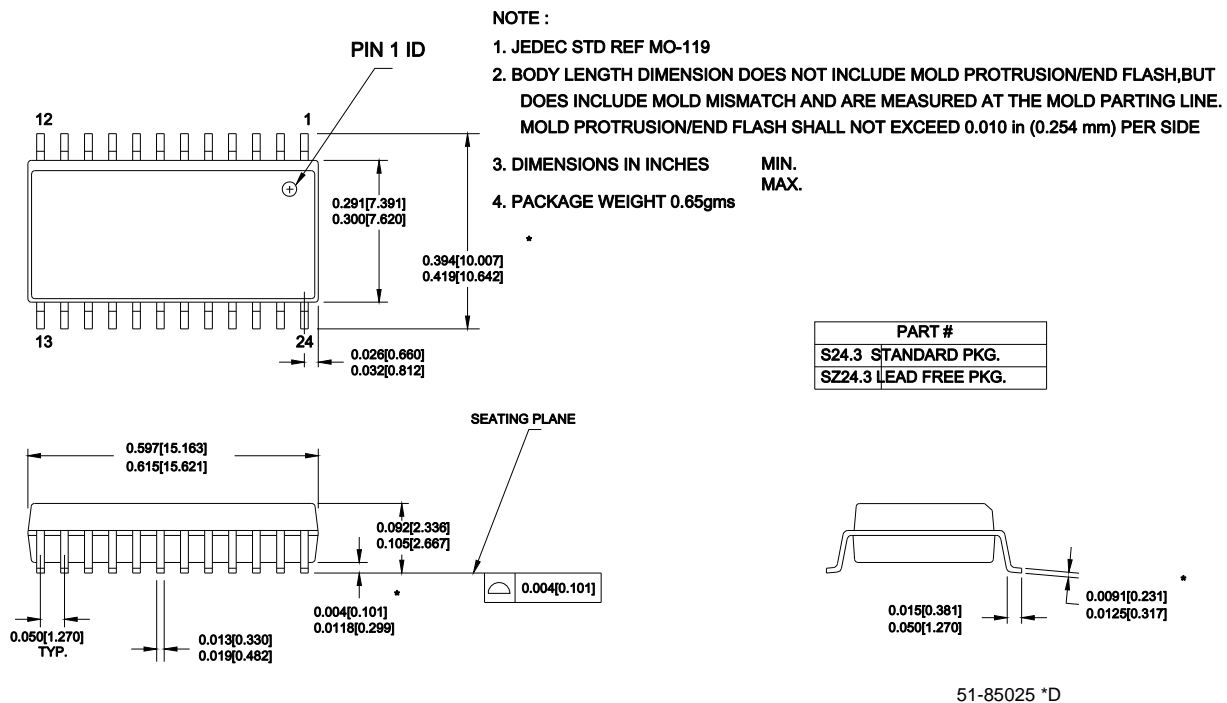

**Note**

20. Not recommended for new design. New designs should use Pb-free devices.

## Document History Page

Document Title: CY7B9910/CY7B9920 Low Skew Clock Buffer				
Document Number: 38-07135				
Revision	ECN	Orig. of Change	Submission Date	Description of Change
**	110244	SZV	10/28/01	Change from Specification number: 38-00437 to 38-07135
*A	1199925	DPF/AESA	See ECN	Added Pb-free parts in Ordering Information Added Note 20: Not recommended for the new design
*B	1353343	AESA	See ECN	Change status to final
*C	2750166	TSAI	08/10/09	Post to external web
*D	2761988	CXQ	09/10/09	Fixed typo from 100W resistor to 100Ω resistor. Added "Not recommended for new designs" note to Pb devices. Fixed incorrect instances of auto-replacement of "lead" to "Pb".
*E	2896073	CXQ	03/19/10	Removed inactive parts from ordering information table Updated package diagram

## Sales, Solutions, and Legal Information

### Worldwide Sales and Design Support

Cypress maintains a worldwide network of offices, solution centers, manufacturer's representatives, and distributors. To find the office closest to you, visit us at [Cypress Locations](#).

### Products

Automotive	<a href="http://cypress.com/go/automotive">cypress.com/go/automotive</a>
Clocks & Buffers	<a href="http://cypress.com/go/clocks">cypress.com/go/clocks</a>
Interface	<a href="http://cypress.com/go/interface">cypress.com/go/interface</a>
Lighting & Power Control	<a href="http://cypress.com/go/powerpsoc">cypress.com/go/powerpsoc</a> <a href="http://cypress.com/go/plc">cypress.com/go/plc</a>
Memory	<a href="http://cypress.com/go/memory">cypress.com/go/memory</a>
Optical & Image Sensing	<a href="http://cypress.com/go/image">cypress.com/go/image</a>
PSoC	<a href="http://cypress.com/go/psoc">cypress.com/go/psoc</a>
Touch Sensing	<a href="http://cypress.com/go/touch">cypress.com/go/touch</a>
USB Controllers	<a href="http://cypress.com/go/USB">cypress.com/go/USB</a>
Wireless/RF	<a href="http://cypress.com/go/wireless">cypress.com/go/wireless</a>

### PSoC Solutions

[psoc.cypress.com/solutions](http://psoc.cypress.com/solutions)  
PSoC 1 | PSoC 3 | PSoC 5

© Cypress Semiconductor Corporation, 2001-2010. The information contained herein is subject to change without notice. Cypress Semiconductor Corporation assumes no responsibility for the use of any circuitry other than circuitry embodied in a Cypress product. Nor does it convey or imply any license under patent or other rights. Cypress products are not warranted nor intended to be used for medical, life support, life saving, critical control or safety applications, unless pursuant to an express written agreement with Cypress. Furthermore, Cypress does not authorize its products for use as critical components in life-support systems where a malfunction or failure may reasonably be expected to result in significant injury to the user. The inclusion of Cypress products in life-support systems application implies that the manufacturer assumes all risk of such use and in doing so indemnifies Cypress against all charges.



Any Source Code (software and/or firmware) is owned by Cypress Semiconductor Corporation (Cypress) and is protected by and subject to worldwide patent protection (United States and foreign), United States copyright laws and international treaty provisions. Cypress hereby grants to licensee a personal, non-exclusive, non-transferable license to copy, use, modify, create derivative works of, and compile the Cypress Source Code and derivative works for the sole purpose of creating custom software and/or firmware in support of licensee product to be used only in conjunction with a Cypress integrated circuit as specified in the applicable agreement. Any reproduction, modification, translation, compilation, or representation of this Source Code except as specified above is prohibited without the express written permission of Cypress.

Disclaimer: CYPRESS MAKES NO WARRANTY OF ANY KIND, EXPRESS OR IMPLIED, WITH REGARD TO THIS MATERIAL, INCLUDING, BUT NOT LIMITED TO, THE IMPLIED WARRANTIES OF MERCHANTABILITY AND FITNESS FOR A PARTICULAR PURPOSE. Cypress reserves the right to make changes without further notice to the materials described herein. Cypress does not assume any liability arising out of the application or use of any product or circuit described herein. Cypress does not authorize its products for use as critical components in life-support systems where a malfunction or failure may reasonably be expected to result in significant injury to the user. The inclusion of Cypress' product in a life-support systems application implies that the manufacturer assumes all risk of such use and in doing so indemnifies Cypress against all charges.

Use may be limited by and subject to the applicable Cypress software license agreement.

## Looking for pricing, stock, or lifecycle information?

Click below to explore more details on WIN SOURCE:

-  [View CY7B9910-2SXC on WIN SOURCE](#)
-  [Cypress Semiconductor Corp Information](#)

## Optimize Your Supply Chain with WIN SOURCE Solutions

-  Global Sourcing Solution
-  Obsolete Management
-  Cost Control Management
-  Shortage Management
-  Alternative Solution
-  Excess Inventory Management