



**THE DATASHEET OF
CDC5806PW**



THREE PLLs BASED CLOCK GENERATOR FOR DIGITAL TV APPLICATIONS

FEATURES

- High Performance Clock Generator
- Clock Input Compatible With LVCMOS/LVTTL
- Requires a 54-MHz Input Clock to Generate Multiple Output Frequencies
- Low Jitter for Clock Distribution
- Generates the Following Clocks:
 - VIDCLK 74.175824 MHz/54 MHz (Buffered)
 - AUDCLK 16.9344 MHz/12.288 MHz
 - CPUCLK 64 MHz
 - ASICCLK 32 MHz
 - USBCLK 48 MHz
 - MCCLK 38.4 MHz/19.2 MHz/12 MHz
- Operates From Single 3.3-V Supply
- Low Peak-to-Peak Period Jitter (150 ps Max)
- PLLs Are Powered Down, if No Valid REF_IN Clock (< 5 MHz) is Detected or the V_{DD} is Below 2 V
- PLL Loop Filter Components Integrated
- Packaged in TSSOP (PW) 20-Pin Package
- Industrial Temperature Range -40°C to 85°C Applications

APPLICATIONS

- Digital Television With a Memory Card Interface

DESCRIPTION

The CDC5806 is a clock generator which synthesizes video clocks, audio clocks, CPU clock, ASIC clock, USB clock, and a memory card clock from a 54-MHz system clock.

Three phase-locked loops (PLLs) are used to generate the different frequencies from the system clock. On-chip loop filters and internal feedback eliminate the need for external components.

Since the CDC5806 is based on PLL circuitry, it requires a stabilization time to achieve phase-lock of the PLLs. The PLL stabilization time begins after the reference clock input has a stable phase and frequency.

The device operates from a single 3.3-V supply voltage. The CDC5806 device is characterized for operation from -40°C to 85°C.

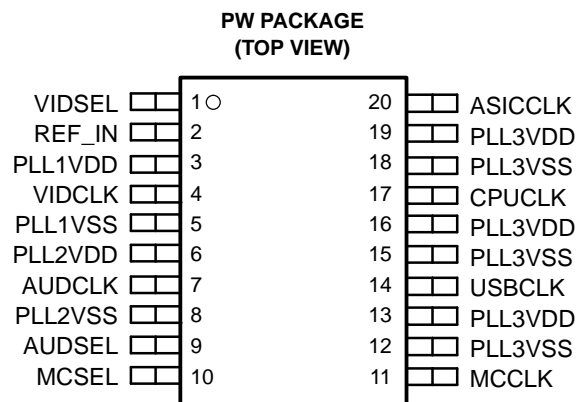

Please be aware that an important notice concerning availability, standard warranty, and use in critical applications of Texas Instruments semiconductor products and disclaimers thereto appears at the end of this data sheet.



These devices have limited built-in ESD protection. The leads should be shorted together or the device placed in conductive foam during storage or handling to prevent electrostatic damage to the MOS gates.

FUNCTIONAL BLOCK DIAGRAM

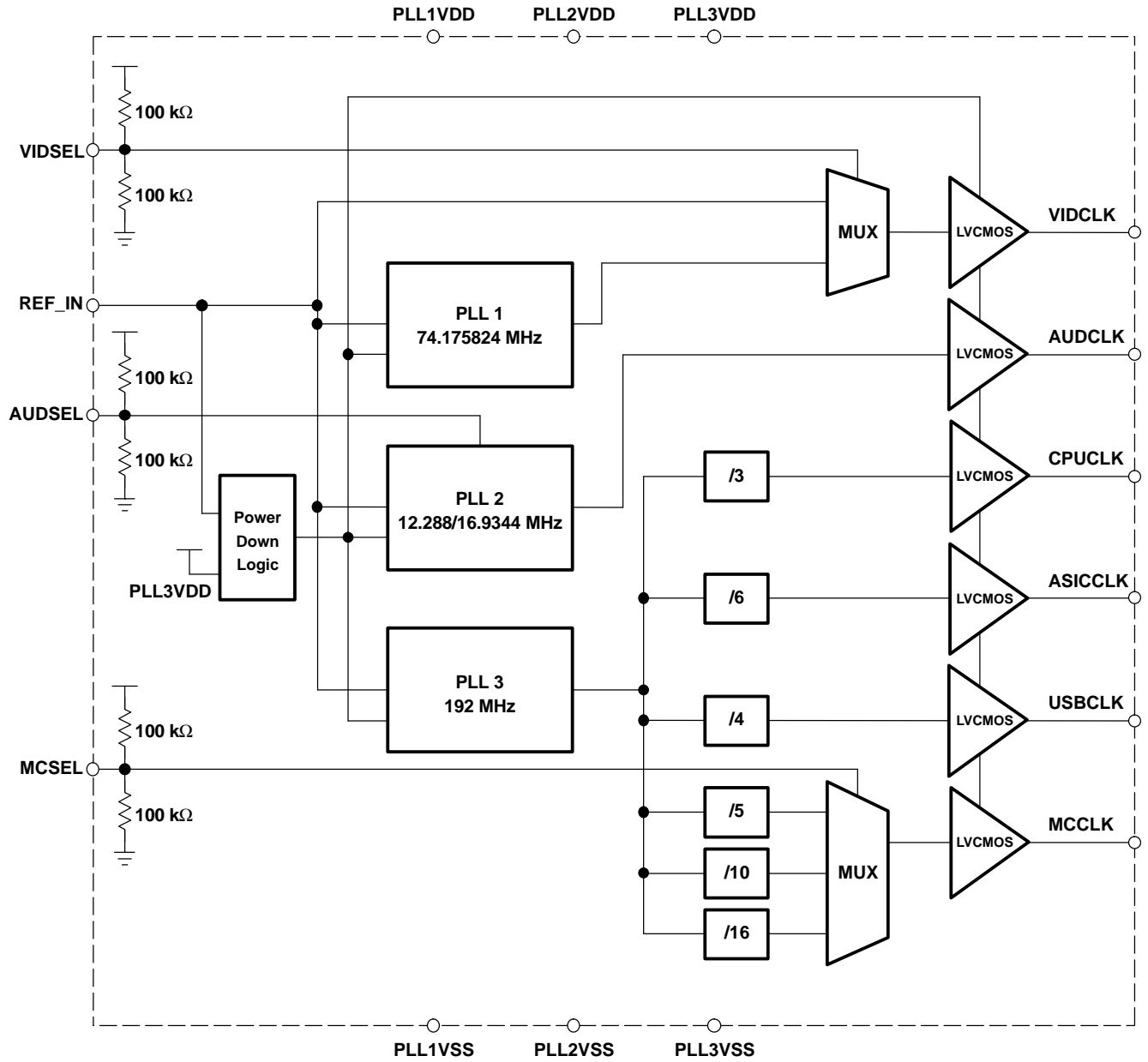

Terminal Functions

TERMINAL NAME	NO	TYPE	DESCRIPTION
REF_IN	2	I LVCMOS	Reference frequency input
VIDSEL	1	I LVCMOS	VIDSEL select input for VIDCLK. It selects between 74.175824 MHz from PLL1 and buffered input frequency of 54 MHz, 100k 100k pull to mid-level.
AUDSEL	9	I LVCMOS	AUDSEL select input for AUDCLK. It selects between 16.9344 MHz and 12.288 MHz from PLL2, 100k 100k pull to mid level.
MCSEL	10	I LVCMOS	MCSEL select input for MCCLK. It selects from 38.4 MHz, 19.2 MHz, and 12 MHz from PLL3, 100k 100k pull to mid level.
VIDCLK	4	O LVCMOS	VIDCLK output 74.175824 MHz or 54 MHz
AUDCLK	7	O LVCMOS	AUDCLK output 16.9344 MHz or 12.288 MHz
CPUCLK	17	O LVCMOS	CPUCLK output 64 MHz
ASICCLK	20	O LVCMOS	ASICCLK output 32 MHz
USBCLK	14	O LVCMOS	USBCLK output 48 MHz
MCCLK	4	O LVCMOS	MCCLK output 38.4 MHz / 19.2 MHz / 12 MHz
VDD_PLL1	3	Power	3.3-V supply for PLL1 and VIDCLK
VDD_PLL2	6	Power	3.3-V supply for PLL2 and AUDCLK
VDD_PLL3	13, 16, 19	Power	3.3-V supply for PLL3 and CPUCLK, ASICCLK, USBCLK, and MCCLK
VSS_PLL1	5	Ground	Ground for PLL1 and VIDCLK
VSS_PLL2	8	Ground	Ground for PLL2 and AUDCLK
VSS_PLL3	12, 15, 18	Ground	Ground for PLL3 and CPUCLK, ASICCLK, USBCLK, and MCCLK

FUNCTIONAL DESCRIPTION OF THE LOGIC

Table 1. Select Function for Video, Audio, CPU, ASIC, and USB Clocks

VIDSEL	AUDSEL	VIDCLK	AUDCLK	CPUCLK	ASICCLK	USBCLK	Unit
L	L	54 (buffered)	12.288	64	32	48	MHz
L	M	Reserved	Reserved	64	32	48	MHz
L	H	54 (buffered)	16.9344	64	32	48	MHz
M	L	Reserved	Reserved	64	32	48	MHz
M	M	Reserved	Reserved	REFCLK/3	REFCLK/6	REFCLK/4	MHz
M	H	Reserved	Reserved	64	32	48	MHz
H	L	74.175824	12.288	64	32	48	MHz
H	M	Reserved	Reserved	64	32	48	MHz
H	H	74.175824	16.9344	64	32	48	MHz

Table 2. Select Function for MC Clock

MCSEL	MCCLK	MCCLK if VIDSEL = M and AUDSEL = M	UNIT
H	12 MHz	REFCLK/16	MHz
M	38.4 MHz	REFCLK/5	MHz
L	19.2 MHz	REFCLK/10	MHz

ABSOLUTE MAXIMUM RATINGS

over operating free-air temperature (unless otherwise noted)⁽¹⁾

Supply voltage range, V_{DD}	0.5 V to 4.6 V
Input voltage range, V_I ⁽²⁾	0.5 V to $V_{DD} + 0.5$ V
Output voltage range, V_O ⁽²⁾	0.5 V to $V_{DD} + 0.5$ V
Input current ($V_I < 0$, $V_I > V_{DD}$)	± 20 mA
Continuous output current, I_O	± 50 mA
Package thermal impedance, θ_{JA} ⁽³⁾ : TSSOP20 package	104 C/W
Storage temperature range T_{stg}	65°C to 150°C

- (1) Stresses beyond those listed under absolute maximum ratings may cause permanent damage to the device. These are stress ratings only, and functional operation of the device at these or any other conditions beyond those indicated under recommended operating conditions is not implied. Exposure to absolute-maximum-rated conditions for extended periods may affect device reliability.
- (2) The input and output negative voltage ratings may be exceeded if the input and output clamp-current ratings are observed.
- (3) The package thermal impedance is calculated in accordance with JESD 51 (no airflow condition) and JEDEC2S1P (high-k board).

RECOMMENDED OPERATING CONDITIONS

	MIN	NOM	MAX	UNIT
V_{DD} Supply voltage	3	3.3	3.6	V
T_A Operating free-air temperature	-40		85	°C
V_{IL} Low-level input voltage REF_IN			0.3 V_{DD}	V
$V_{I\text{ thresh}}$ Input voltage threshold REF_IN		0.5 V_{DD}		V
V_{IH} High-level input voltage REF_IN	0.7 V_{DD}			V
$V_{IL(L)}$ Three level input low for control inputs			0.13 V_{DD}	V
$V_{IM(M)}$ Three level input mid for control inputs	0.4 V_{DD}		0.6 V_{DD}	V
$V_{IH(H)}$ Three level input high for control inputs	0.87 V_{DD}			V
I_{OH} High-level output current LVCMOS			-8	mA
I_{OL} Low-level output current LVCMOS			8	mA
V_I Input voltage range LVCMOS	0		3.6	V
C_L Output load LVCMOS	5		10	pF

TIMING REQUIREMENTS

over recommended ranges of supply voltage, load, and operating free-air temperature

PARAMETER	MIN	NOM	MAX	UNIT
REF_IN REQUIREMENTS				
f_{CLK_IN} LVCMOS REF_IN clock input frequency		54		MHz
t_r / t_f Rise and fall time REF_IN signal (20% to 80%)			4	ns
duty _{REF} Duty cycle of REF_IN ($V_{DD}/2$)	40%		60%	
AUDSEL, VIDSEL, MCSEL REQUIREMENTS				
t_r / t_f Rise and fall time (20% to 80%)			4	ns
t_1 Transitional time between AUDSEL and VIDSEL control pins ⁽¹⁾	6			ns

- (1) If VIDSEL and AUDSEL are switched from from one state to another state at the same time, then the CPUCLK, ASICCLK, USBCLK, or MCCLK are affected. This is due to the selected reserved mode with VIDSEL = M and AUDSEL = M. This mode causes the PLL3 to be bypassed and the REFCLK will be seen with the appropriate divider ratios at the correspondent outputs.

DEVICE CHARACTERISTICS

over recommended operating free-air temperature range (unless otherwise noted)

PARAMETER		TEST CONDITIONS	MIN	TYP	MAX	UNIT	
OVERALL							
I_{CC}	Supply current	Test load		35	45	mA	
$I_{CC(ST)}$	Standby current	$f_{IN} = 0$ MHz, $V_{DD} = 3.6$ V			1.1	mA	
V_{PUC}	Supply voltage threshold for power up control circuit			2		V	
LVCMOS							
V_{IK}	LVCMOS input voltage	$V_{DD} = 3$ V, $I_I = -18$ mA			-1.2	V	
I_I	REF_IN input current	$V_I = 0$ V or V_{DD}			± 5	μ A	
I_I	SELECT input current	$V_I = 0$ V or V_{DD}			± 55	μ A	
V_{OH}	High-level output voltage	$V_{DD} = \text{MIN to MAX}$, $I_{OH} = -5$ mA	$V_{DD} - 0.4$			V	
V_{OL}	Low-level output voltage	$V_{DD} = \text{MIN to MAX}$, $I_{OL} = 5$ mA			0.4	V	
I_{OH}	High-level output current	$V_{DD} = 3$ V, $V_O = V_{DD} - 0.4$ V		-5		mA	
		$V_{DD} = 3.3$ V, $V_O = 1.65$ V			-35		
		$V_{DD} = 3.6$ V, $V_O = 0.4$ V					-75
I_{OL}	Low-level output current	$V_{DD} = 3$ V, $V_O = 0.4$ V		5		mA	
		$V_{DD} = 3.3$ V, $V_O = 1.65$ V			35		
		$V_{DD} = 3.6$ V, $V_O = V_{DD} - 0.4$ V					75
AC							
C_I	Input capacitance (Ref_IN)			2		pF	
f_{err}	Output accuracy VIDCLK, CPUCLK, ASICCLK, USBCLK, MCCLK (38.4 MHz, 19.2 MHz, 12 MHz)	See Note (1)			± 1	ppm	
f_{err}	Output accuracy AUDCLK (16.9344 MHz, 12.288 MHz)	See Note (1)			± 40	ppm	
t_L	PLL start up lock time	See Figure 2			0.5	ms	
$t_{L(\omega)}$	PLL lock time after frequency change on AUDCLK	See Figure 2			0.5	ms	
odc	Duty cycle for MCCLK	Threshold = $V_{DD}/2$	47%	50%	53%		
odc	Duty cycle for VIDCLK, AUDCLK, CPUCLK, ASICCLK, USBCLK	Threshold = $V_{DD}/2$	45%	50%	55%		
t_r/t_f	Rise and fall time of the output	20%–80% of V_O			2	ns	
$t_{jit(per)}$	Peak-to-peak period jitter for	VIDCLK (74.175824 MHz)	10,000 cycles		75	150	ps
		CPUCLK (64 MHz)			60	150	
		USBCLK (48 MHz)			65	150	
		MCCLK (38.4 MHz)			65	150	
		ASICCLK (32 MHz)			60	150	
		MCCLK (19.2 MHz)			70	150	
		AUDCLK (16.9344 MHz)			75	150	
		AUDCLK (12.288 MHz)			85	150	
MCCLK (12 MHz)		65	150				

(1) This parameter is assured by design as a result of the chosen settings of the internal dividers in the PLL's.

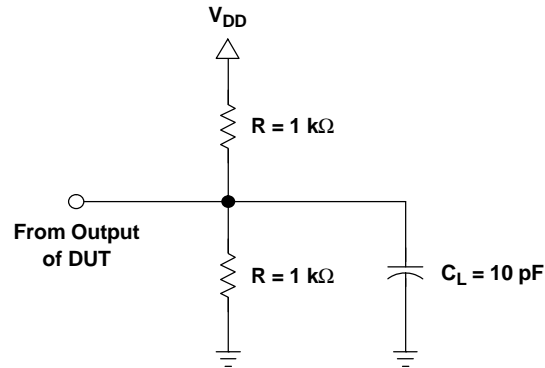

Figure 1. LVC MOS Output Test Load

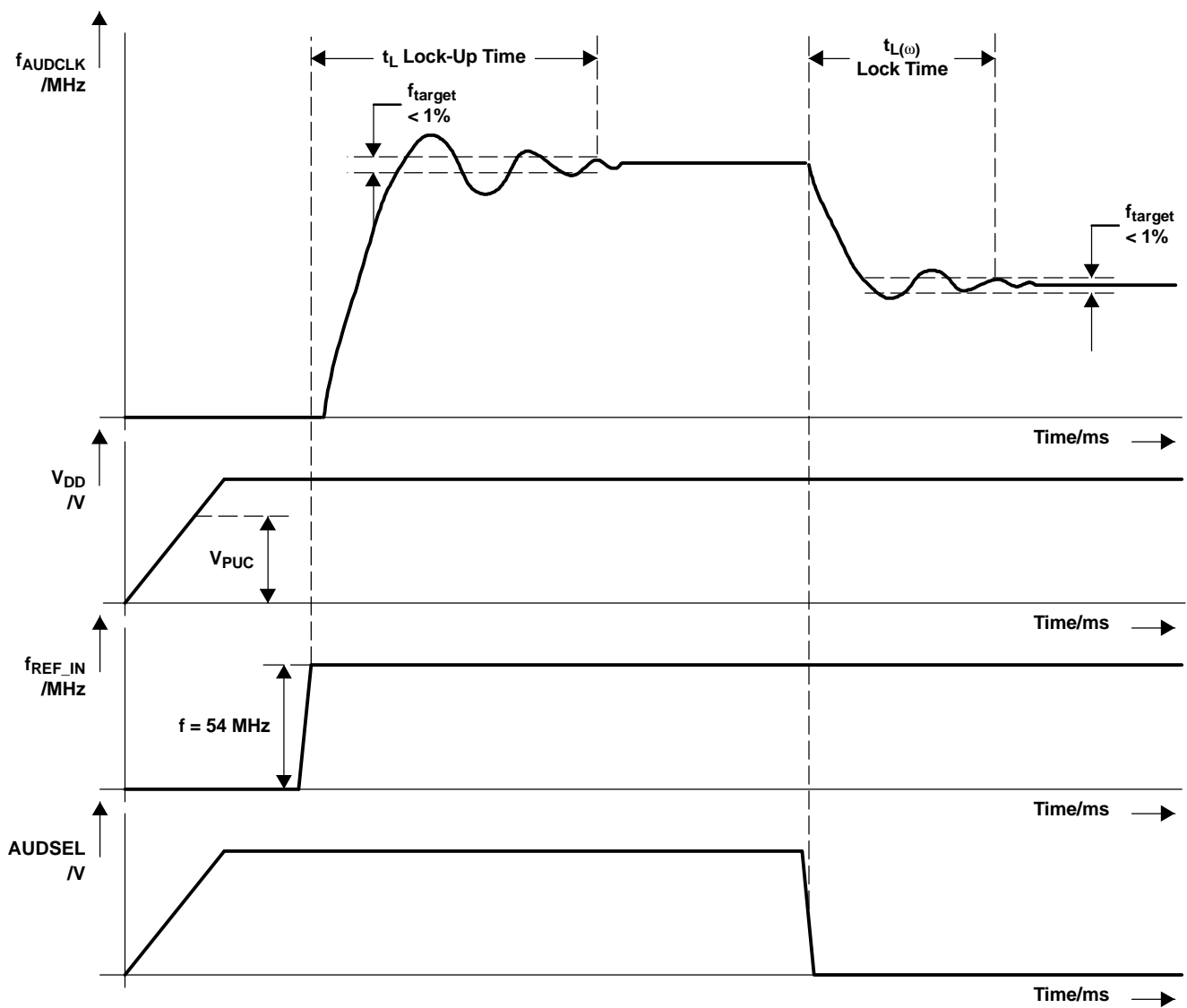
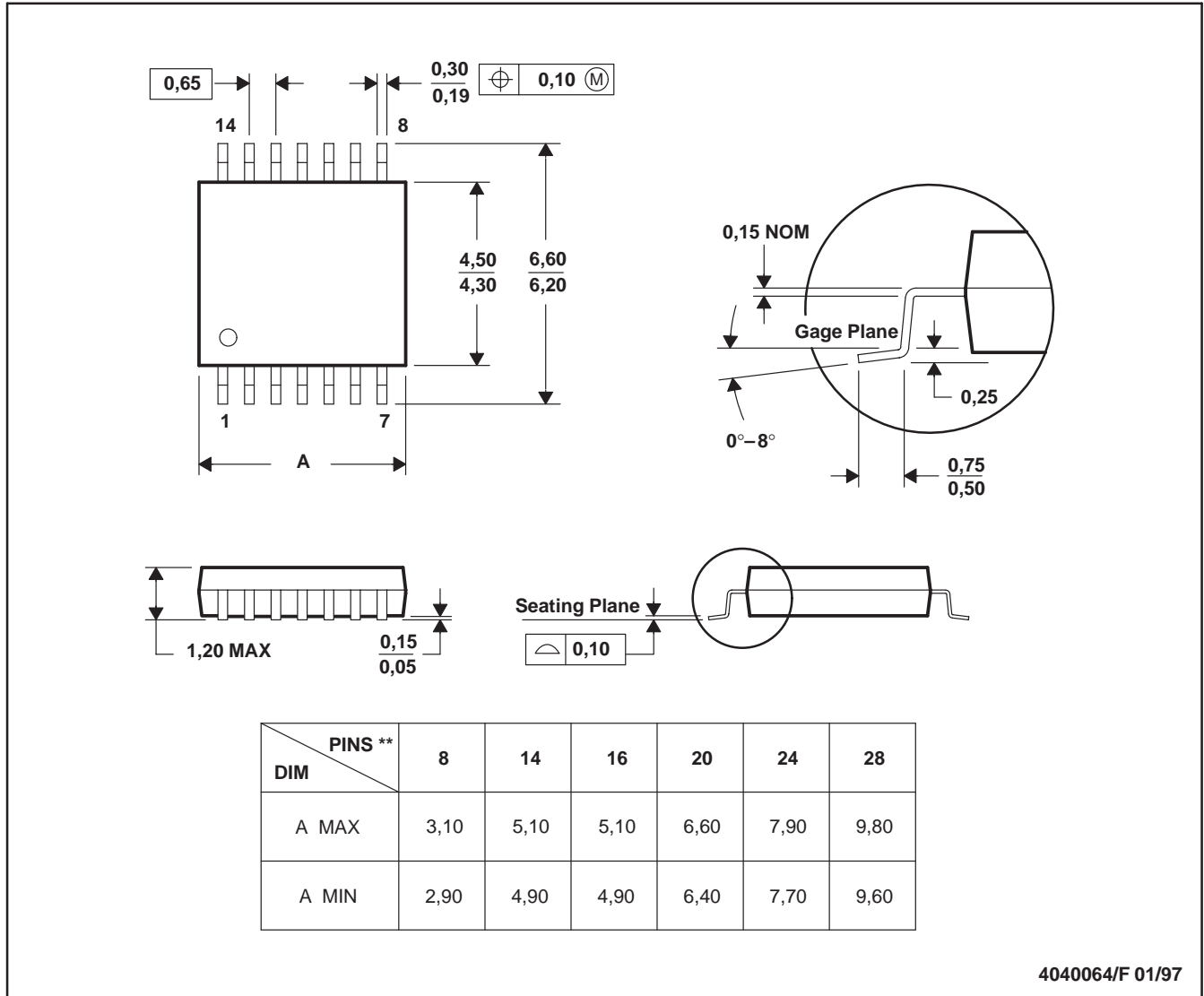

Figure 2. Timing Diagram of PLL Lock Time of Audio Clock

PW (R-PDSO-G**)

PLASTIC SMALL-OUTLINE PACKAGE

14 PINS SHOWN



4040064/F 01/97

- NOTES: A. All linear dimensions are in millimeters.
 B. This drawing is subject to change without notice.
 C. Body dimensions do not include mold flash or protrusion not to exceed 0,15.
 D. Falls within JEDEC MO-153

IMPORTANT NOTICE

Texas Instruments Incorporated and its subsidiaries (TI) reserve the right to make corrections, modifications, enhancements, improvements, and other changes to its products and services at any time and to discontinue any product or service without notice. Customers should obtain the latest relevant information before placing orders and should verify that such information is current and complete. All products are sold subject to TI's terms and conditions of sale supplied at the time of order acknowledgment.

TI warrants performance of its hardware products to the specifications applicable at the time of sale in accordance with TI's standard warranty. Testing and other quality control techniques are used to the extent TI deems necessary to support this warranty. Except where mandated by government requirements, testing of all parameters of each product is not necessarily performed.

TI assumes no liability for applications assistance or customer product design. Customers are responsible for their products and applications using TI components. To minimize the risks associated with customer products and applications, customers should provide adequate design and operating safeguards.

TI does not warrant or represent that any license, either express or implied, is granted under any TI patent right, copyright, mask work right, or other TI intellectual property right relating to any combination, machine, or process in which TI products or services are used. Information published by TI regarding third-party products or services does not constitute a license from TI to use such products or services or a warranty or endorsement thereof. Use of such information may require a license from a third party under the patents or other intellectual property of the third party, or a license from TI under the patents or other intellectual property of TI.

Reproduction of information in TI data books or data sheets is permissible only if reproduction is without alteration and is accompanied by all associated warranties, conditions, limitations, and notices. Reproduction of this information with alteration is an unfair and deceptive business practice. TI is not responsible or liable for such altered documentation.

Resale of TI products or services with statements different from or beyond the parameters stated by TI for that product or service voids all express and any implied warranties for the associated TI product or service and is an unfair and deceptive business practice. TI is not responsible or liable for any such statements.

Following are URLs where you can obtain information on other Texas Instruments products and application solutions:

Products		Applications	
Amplifiers	amplifier.ti.com	Audio	www.ti.com/audio
Data Converters	dataconverter.ti.com	Automotive	www.ti.com/automotive
DSP	dsp.ti.com	Broadband	www.ti.com/broadband
Interface	interface.ti.com	Digital Control	www.ti.com/digitalcontrol
Logic	logic.ti.com	Military	www.ti.com/military
Power Mgmt	power.ti.com	Optical Networking	www.ti.com/opticalnetwork
Microcontrollers	microcontroller.ti.com	Security	www.ti.com/security
		Telephony	www.ti.com/telephony
		Video & Imaging	www.ti.com/video
		Wireless	www.ti.com/wireless

Mailing Address: Texas Instruments
Post Office Box 655303 Dallas, Texas 75265

Looking for pricing, stock, or lifecycle information?

Click below to explore more details on WIN SOURCE:

 [View CDC5806PW](#) on WIN SOURCE

 [Texas Instruments](#) Information

Optimize Your Supply Chain with WIN SOURCE Solutions

-  Global Sourcing Solution
-  Obsolete Management
-  Cost Control Management
-  Shortage Management
-  Alternative Solution
-  Excess Inventory Management