



**THE DATASHEET OF
LMZ31707RVQT**



LMZ31707 7-A Power module with 2.95-V to 17-V input and current sharing in QFN package

1 Features

- Complete integrated power solution allows small footprint, low-profile design
- 10 mm × 10 mm × 4.3 mm package
 - Pin compatible with LMZ31710 and LMZ31704
- Efficiencies Up To 95%
- Eco-mode™ / light load efficiency (LLE)
- Wide-output voltage adjust
0.6 V to 5.5 V, with 1% reference accuracy
- Supports parallel operation for higher current
- Optional split power rail allows input voltage down to 2.95 V
- Adjustable switching frequency
(200 kHz to 1.2 MHz)
- Synchronizes to an external clock
- Provides 180° out-of-phase clock signal
- Adjustable slow start
- Output voltage sequencing / tracking
- Power good output
- Programmable undervoltage lockout (UVLO)
- Overcurrent and overtemperature protection
- Pre-Bias output start-up
- Operating temperature range: –40°C to +85°C
- Enhanced thermal performance: 13.3°C/W
- Meets EN55022 Class B emissions
 - Integrated shielded inductor
- Create a custom design using the LMZ31707 with the [WEBENCH® Power Designer](#)

2 Applications

- Broadband and communications infrastructure
- Automated test and medical equipment
- Compact PCI / PCI express / PXI express
- DSP and FPGA point-of-load applications

3 Description

The LMZ31707 SIMPLE SWITCHER® power module is an easy-to-use integrated power solution that combines a 7-A DC-DC converter with power MOSFETs, a shielded inductor, and passives into a low profile, QFN package. This total power solution allows as few as three external components and eliminates the loop compensation and magnetics part selection process.

The 10 × 10 × 4.3 mm QFN package is easy to solder onto a printed circuit board and allows a compact point-of-load design. Achieves greater than 95% efficiency and excellent power dissipation capability with a thermal impedance of 13.3°C/W. The LMZ31707 offers the flexibility and the feature-set of a discrete point-of-load design and is ideal for powering a wide range of ICs and systems. Advanced packaging technology affords a robust and reliable power solution compatible with standard QFN mounting and testing techniques.

Simplified Application

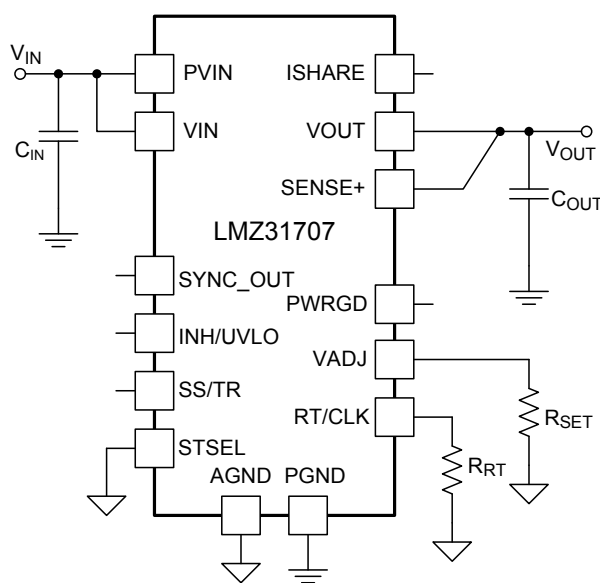

4 Specifications

4.1 Absolute Maximum Ratings⁽¹⁾

over operating temperature range (unless otherwise noted)

| | | MIN | MAX | UNIT |
|--|--|------|--------------------|------|
| Input Voltage | VIN, PVIN | -0.3 | 20 | V |
| | INH/UVLO, PWRGD, RT/CLK, SENSE+ | -0.3 | 6 | V |
| | ILIM, VADJ, SS/TR, STSEL, SYNC_OUT, ISHARE, OCP_SEL | -0.3 | 3 | V |
| Output Voltage | PH | -1 | 20 | V |
| | PH 10ns Transient | -3 | 20 | V |
| | VOUT | -0.3 | 6 | V |
| Source Current | RT/CLK, INH/UVLO | | ±100 | µA |
| | PH | | current limit | A |
| Sink Current | PH | | current limit | A |
| | PVIN | | current limit | A |
| | PWRGD | -0.1 | 2 | mA |
| Operating Junction Temperature | | -40 | 125 ⁽²⁾ | °C |
| Storage Temperature | | -65 | 150 | °C |
| Peak Reflow Case Temperature ⁽³⁾ | | | 245 ⁽⁴⁾ | °C |
| Maximum Number of Reflows Allowed ⁽³⁾ | | | 3 ⁽⁴⁾ | |
| Mechanical Shock | Mil-STD-883D, Method 2002.3, 1 msec, 1/2 sine, mounted | | 1500 | G |
| Mechanical Vibration | Mil-STD-883D, Method 2007.2, 20-2000Hz | | 20 | |

- (1) Stresses beyond those listed under absolute maximum ratings may cause permanent damage to the device. These are stress ratings only, and functional operation of the device at these or any other conditions beyond those indicated under recommended operating conditions is not implied. Exposure to absolute-maximum-rated conditions for extended periods may affect device reliability.
- (2) See the temperature derating curves in the Typical Characteristics section for thermal information.
- (3) For soldering specifications, refer to the [Soldering Requirements for BQFN Packages](#) application note.
- (4) Devices with a date code prior to week 14 2018 (1814) have a peak reflow case temperature of 240°C with a maximum of one reflow.

4.2 ESD Ratings

| | | VALUE | UNIT |
|--|--|-------|------|
| V _(ESD) Electrostatic discharge | Human-body model (HBM), per ANSI/ESDA/JEDEC JS-001 ⁽¹⁾ | ±1500 | V |
| | Charged-device model (CDM), per JEDEC specification JESD22-C101 ⁽²⁾ | ±1000 | |

- (1) JEDEC document JEP155 states that 500-V HBM allows safe manufacturing with a standard ESD control process.
- (2) JEDEC document JEP157 states that 250-V CDM allows safe manufacturing with a standard ESD control process.

4.3 Recommended Operating Conditions

over operating free-air temperature range (unless otherwise noted)

| | | MIN | NOM | MAX | UNIT |
|------------------|-------------------------|------|-----|------|------|
| PV _{IN} | Input Switching Voltage | 2.95 | | 17 | V |
| V _{IN} | Input Bias Voltage | 4.5 | | 17 | V |
| V _{OUT} | Output Voltage | 0.6 | | 5.5 | V |
| f _{SW} | Switching Frequency | 200 | | 1200 | kHz |

4.4 Package Specifications

| LMZ31707 | | UNIT |
|-----------------------------|---|------------|
| Weight | | 1.45 grams |
| Flammability | Meets UL 94 V-O | |
| MTBF Calculated reliability | Per Bellcore TR-332, 50% stress, T _A = 40°C, ground benign | 37.4 Mhrs |

4.5 Thermal Information

| THERMAL METRIC ⁽¹⁾ | | LMZ31707 | UNIT |
|-------------------------------|---|----------|------|
| | | RVQ42 | |
| | | 42 PINS | |
| θ_{JA} | Junction-to-ambient thermal resistance ⁽²⁾ | 13.3 | °C/W |
| Ψ_{JT} | Junction-to-top characterization parameter ⁽³⁾ | 1.6 | °C/W |
| Ψ_{JB} | Junction-to-board characterization parameter ⁽⁴⁾ | 5.3 | °C/W |

- (1) For more information about traditional and new thermal metrics, see the *Semiconductor and IC Package Thermal Metrics* application report.
- (2) The junction-to-ambient thermal resistance, θ_{JA} , applies to devices soldered directly to a 100 mm x 100 mm double-sided PCB with 2 oz. copper and natural convection cooling. Additional airflow reduces θ_{JA} .
- (3) The junction-to-top characterization parameter, Ψ_{JT} , estimates the junction temperature, T_J , of a device in a real system, using a procedure described in JESD51-2A (sections 6 and 7). $T_J = \Psi_{JT} * P_{dis} + T_T$; where P_{dis} is the power dissipated in the device and T_T is the temperature of the top of the device.
- (4) The junction-to-board characterization parameter, Ψ_{JB} , estimates the junction temperature, T_J , of a device in a real system, using a procedure described in JESD51-2A (sections 6 and 7). $T_J = \Psi_{JB} * P_{dis} + T_B$; where P_{dis} is the power dissipated in the device and T_B is the temperature of the board 1mm from the device.

4.6 Electrical Characteristics

Over -40°C to 85°C free-air temperature, $P_{VIN} = V_{IN} = 12\text{ V}$, $V_{OUT} = 1.8\text{ V}$, $I_{OUT} = 7\text{ A}$,
 $C_{IN} = 0.1\text{ }\mu\text{F} + 2 \times 22\text{ }\mu\text{F}$ ceramic + $100\text{ }\mu\text{F}$ bulk, $C_{OUT} = 4 \times 47\text{ }\mu\text{F}$ ceramic (unless otherwise noted) ⁽¹⁾

| PARAMETER | | TEST CONDITIONS | MIN | TYP | MAX | UNIT | | |
|--------------------|--|--|--|-------------------------|--------------------------|----------------------------|----|-------------------|
| I_{OUT} | Output current | $T_A = 85^{\circ}\text{C}$, natural convection | 0 | | 7 | A | | |
| V_{IN} | Input bias voltage range | Over output current range | 4.5 | | 17 | V | | |
| P_{VIN} | Input switching voltage range | Over output current range | 2.95 ⁽²⁾ | | 17 ⁽³⁾ | V | | |
| UVLO | V_{IN} Undervoltage lockout | V_{IN} Increasing | | 4.0 | 4.5 | V | | |
| | | V_{IN} Decreasing | 3.5 | 3.85 | | | | |
| $V_{OUT(adj)}$ | Output voltage adjust range | Over output current range | 0.6 | | 5.5 | V | | |
| V_{OUT} | Set-point voltage tolerance | $T_A = 25^{\circ}\text{C}$, $I_{OUT} = 0\text{ A}$ | | | $\pm 1\%$ ⁽⁴⁾ | | | |
| | Temperature variation | $-40^{\circ}\text{C} \leq T_A \leq +85^{\circ}\text{C}$, $I_{OUT} = 0\text{ A}$ | | $\pm 0.2\%$ | | | | |
| | Line regulation | Over input voltage range | | $\pm 0.1\%$ | | | | |
| | Load regulation | Over output current range | | $\pm 0.2\%$ | | | | |
| | Total output voltage variation | Includes set-point, line, load, and temperature variation | | | | $\pm 1.5\%$ ⁽⁴⁾ | | |
| η | Efficiency | $P_{VIN} = V_{IN} = 12\text{ V}$ $I_O = 4\text{ A}$ | $V_{OUT} = 5.0\text{ V}$, $f_{SW} = 1\text{ MHz}$ | | 94 % | | | |
| | | | $V_{OUT} = 3.3\text{ V}$, $f_{SW} = 750\text{ kHz}$ | | 92 % | | | |
| | | | $V_{OUT} = 2.5\text{ V}$, $f_{SW} = 750\text{ kHz}$ | | 90 % | | | |
| | | | $V_{OUT} = 1.8\text{ V}$, $f_{SW} = 500\text{ kHz}$ | | 89 % | | | |
| | | | $V_{OUT} = 1.2\text{ V}$, $f_{SW} = 300\text{ kHz}$ | | 87 % | | | |
| | | | $V_{OUT} = 0.9\text{ V}$, $f_{SW} = 250\text{ kHz}$ | | 85 % | | | |
| | | $P_{VIN} = V_{IN} = 5\text{ V}$ $I_O = 4\text{ A}$ | $V_{OUT} = 3.3\text{ V}$, $f_{SW} = 750\text{ kHz}$ | | 95 % | | | |
| | | | $V_{OUT} = 2.5\text{ V}$, $f_{SW} = 750\text{ kHz}$ | | 93 % | | | |
| | | | $V_{OUT} = 1.8\text{ V}$, $f_{SW} = 500\text{ kHz}$ | | 92 % | | | |
| | | | $V_{OUT} = 1.2\text{ V}$, $f_{SW} = 300\text{ kHz}$ | | 90 % | | | |
| | | | $V_{OUT} = 0.9\text{ V}$, $f_{SW} = 250\text{ kHz}$ | | 87 % | | | |
| | | | $V_{OUT} = 0.6\text{ V}$, $f_{SW} = 200\text{ kHz}$ | | 84 % | | | |
| | | | Output voltage ripple | 20 MHz bandwidth | | 14 | | mV _{P-P} |
| | | | I_{LIM} | Current limit threshold | ILIM pin open | | 12 | |
| ILIM pin to AGND | | 9 | | | | A | | |
| Transient response | 1.0 A/ μs load step from 25 to 75% $I_{OUT(max)}$ | Recovery time | | tbd | | μs | | |
| | | VOUT over/undershoot | | tbd | | mV | | |

- (1) See the **Light Load Efficiency (LLE)** section for more information for output voltages < 1.5 V.
- (2) The minimum P_{VIN} is 2.95 V or ($V_{OUT} + 0.7\text{ V}$), whichever is greater. See **Table 7** for more details.
- (3) The maximum P_{VIN} voltage is 17 V or ($22 \times V_{OUT}$), whichever is less. See **Table 7** for more details.
- (4) The stated limit of the set-point voltage tolerance includes the tolerance of both the internal voltage reference and the internal adjustment resistor. The overall output voltage tolerance will be affected by the tolerance of the external R_{SET} resistor.

Electrical Characteristics (continued)

Over -40°C to 85°C free-air temperature, $V_{\text{IN}} = V_{\text{VIN}} = 12\text{ V}$, $V_{\text{OUT}} = 1.8\text{ V}$, $I_{\text{OUT}} = 7\text{ A}$,
 $C_{\text{IN}} = 0.1\text{ }\mu\text{F} + 2 \times 22\text{ }\mu\text{F}$ ceramic + $100\text{ }\mu\text{F}$ bulk, $C_{\text{OUT}} = 4 \times 47\text{ }\mu\text{F}$ ceramic (unless otherwise noted) ⁽¹⁾

| PARAMETER | | TEST CONDITIONS | MIN | TYP | MAX | UNIT |
|----------------------|-----------------------------------|--------------------------------------|-------------------|--------------------|---------------------|--------------------|
| V_{INH} | Inhibit threshold voltage | Inhibit High Voltage | 1.3 | | open ⁽⁵⁾ | V |
| | | Inhibit Low Voltage | -0.3 | | 1.1 | |
| I_{INH} | INH Input current | $V_{\text{INH}} < 1.1\text{ V}$ | | -1.15 | | μA |
| | INH Hysteresis current | $V_{\text{INH}} > 1.3\text{ V}$ | | -3.3 | | μA |
| $I_{\text{I(stby)}}$ | Input standby current | INH pin to AGND | | 2 | 10 | μA |
| Power Good | PWRGD Thresholds | V_{OUT} rising | Good | 95% | | |
| | | | Fault | 108% | | |
| | | V_{OUT} falling | Fault | 91% | | |
| | | | Good | 104% | | |
| PWRGD Low Voltage | $I(\text{PWRGD}) = 0.5\text{ mA}$ | | | 0.3 | V | |
| f_{SW} | Switching frequency | $R_{\text{RT}} = 169\text{ k}\Omega$ | 400 | 500 | 600 | kHz |
| f_{CLK} | Synchronization frequency | CLK Control | 200 | | 1200 | kHz |
| $V_{\text{CLK-H}}$ | CLK High-Level | | 2.0 | | 5.5 | V |
| $V_{\text{CLK-L}}$ | CLK Low-Level | | | | 0.5 | V |
| D_{CLK} | CLK Duty Cycle | | 20 | 50 | 80 | % |
| | Thermal Shutdown | | Thermal shutdown | | 175 | |
| | | Thermal shutdown hysteresis | | 10 | | $^{\circ}\text{C}$ |
| C_{IN} | External input capacitance | Ceramic | 44 ⁽⁶⁾ | | | μF |
| | | Non-ceramic | | 100 ⁽⁶⁾ | | |
| C_{OUT} | External output capacitance | Ceramic | 47 ⁽⁷⁾ | 200 | 1500 | μF |
| | | Non-ceramic | | 220 ⁽⁷⁾ | 5000 ⁽⁸⁾ | |
| | | Equivalent series resistance (ESR) | | | | 35 |

- (5) This pin has an internal pull-up. If it is left open, the device operates when input power is applied. A small, low-leakage MOSFET is recommended for control. When the device is operating and no UVLO resistor divider is present on this pin, the open voltage is typically 2.9 V.
- (6) A minimum of 44 μF of external ceramic capacitance is required across the input (V_{IN} and P_{VIN} connected) for proper operation. An additional 100 μF of bulk capacitance is recommended. It is also recommended to place a 0.1 μF ceramic capacitor directly across the P_{VIN} and P_{GND} pins of the device. Locate the input capacitance close to the device. When operating with split V_{IN} and P_{VIN} rails, place 4.7 μF of ceramic capacitance directly at the V_{IN} pin. See [Table 4](#) for more details.
- (7) The amount of required output capacitance varies depending on the output voltage (see [Table 3](#)). The amount of required capacitance must include at least 1x 47 μF ceramic capacitor. Locate the capacitance close to the device. Adding additional capacitance close to the load improves the response of the regulator to load transients. See [Table 3](#) and [Table 4](#) more details.
- (8) When using both ceramic and non-ceramic output capacitors, the combined maximum must not exceed 5000 μF . It may be necessary to increase the slow start time when turning on into the maximum capacitance. See the [Slow Start \(SS/TR\)](#) section for information on adjusting the slow start time.

5 Device Information

Functional Block Diagram

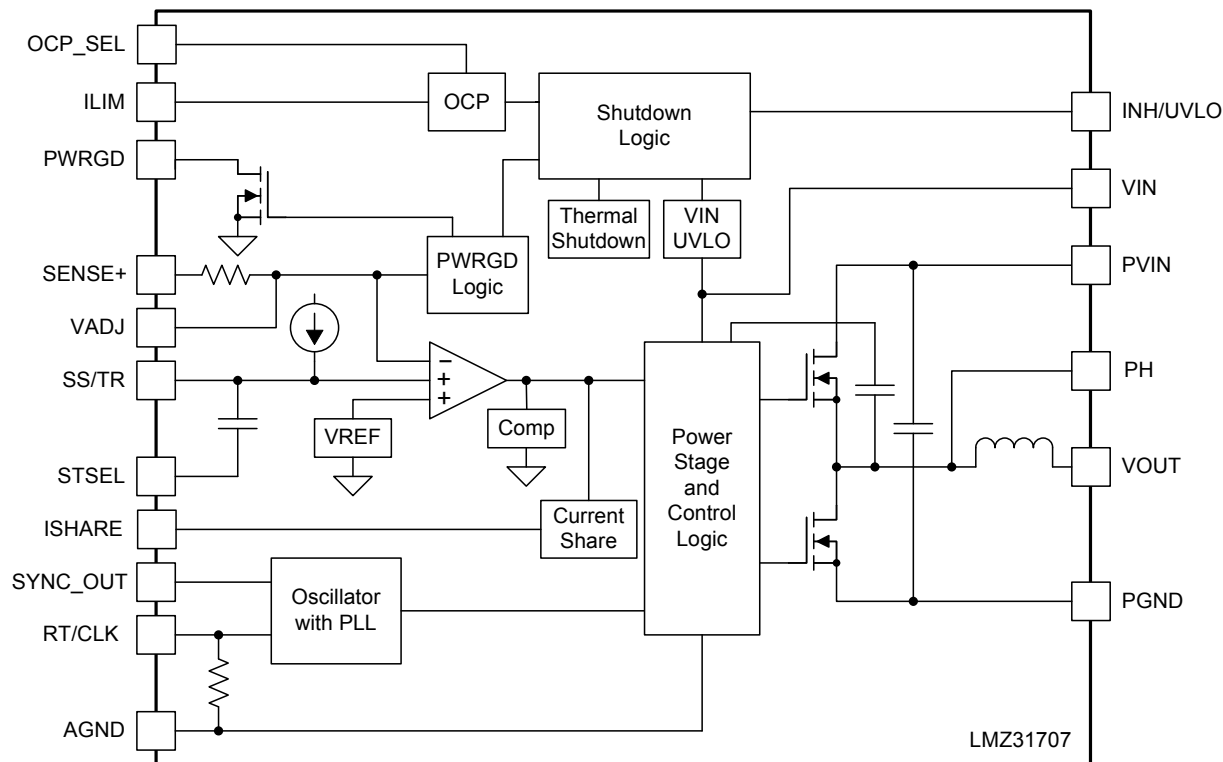

Pin Functions

| TERMINAL | | DESCRIPTION |
|----------|-----|--|
| NAME | NO. | |
| AGND | 2 | Zero volt reference for the analog control circuit. These pins are not connected together internal to the device and must be connected to one another using an AGND plane of the PCB. These pins are associated with the internal analog ground (AGND) of the device. Keep AGND separate from PGND, as a single connection is made internal to the device. See Layout Recommendations. |
| | 23 | |
| PGND | 20 | This is the return current path for the power stage of the device. Connect these pins to the load and to the bypass capacitors associated with PVIN and VOUT. Keep PGND separate from AGND, as a single connection is made internal to the device. |
| | 21 | |
| | 31 | |
| | 32 | |
| | 33 | |
| VIN | 3 | Input bias voltage pin. Supplies the control circuitry of the power converter. Connect this pin to the input bias supply. Connect bypass capacitors between this pin and PGND. |
| PVIN | 1 | Input switching voltage. Supplies voltage to the power switches of the converter. Connect these pins to the input supply. Connect bypass capacitors between these pins and PGND. |
| | 11 | |
| | 12 | |
| | 39 | |
| | 40 | |
| VOUT | 34 | Output voltage. These pins are connected to the internal output inductor. Connect these pins to the output load and connect external bypass capacitors between these pins and PGND. |
| | 35 | |
| | 36 | |
| | 37 | |
| | 41 | |
| PH | 10 | Phase switch node. These pins must be connected to one another using a small copper island under the device for thermal relief. Do not place any external component on these pins or tie them to a pin of another function. |
| | 13 | |
| | 14 | |
| | 15 | |
| | 16 | |
| | 17 | |
| | 18 | |
| | 19 | |
| DNC | 5 | Do Not Connect. Do not connect these pins to AGND, to another DNC pin, or to any other voltage. These pins are connected to internal circuitry. Each pin must be soldered to an isolated pad. |
| | 9 | |
| | 24 | |
| ISHARE | 25 | Current share pin. Connect this pin to other LMZ31707 device's ISHARE pin when paralleling multiple LMZ31707 devices. When unused, treat this pin as a Do Not Connect (DNC) and leave it isolated from all other signals or ground. |
| OCP_SEL | 4 | Over current protection select pin. Leave this pin open for hiccup mode operation. Connect this pin to AGND for cycle-by-cycle operation. See Overcurrent Protection for more details. |
| ILIM | 6 | Current limit pin. Leave this pin open for full current limit threshold. Connect this pin to AGND to reduce the current limit threshold by approximately 3 A. |
| SYNC_OUT | 7 | Synchronization output pin. Provides a 180° out-of-phase clock signal. |
| PWRGD | 8 | Power Good flag pin. This open drain output asserts low if the output voltage is more than approximately ±6% out of regulation. A pull-up resistor is required. |
| RT/CLK | 22 | This pin is connected to an internal frequency setting resistor which sets the default switching frequency. An external resistor can be connected from this pin to AGND to increase the frequency. This pin can also be used to synchronize to an external clock. |
| VADJ | 26 | Connecting a resistor between this pin and AGND sets the output voltage. |
| SENSE+ | 27 | Remote sense connection. This pin must be connected to VOUT at the load or at the device pins. Connect this pin to VOUT at the load for improved regulation. |

Pin Functions (continued)

| TERMINAL | | DESCRIPTION |
|----------|-----|--|
| NAME | NO. | |
| SS/TR | 28 | Slow-start and tracking pin. Connecting an external capacitor to this pin adjusts the output voltage rise time. A voltage applied to this pin allows for tracking and sequencing control. |
| STSEL | 29 | Slow-start or track feature select. Connect this pin to AGND to enable the internal SS capacitor. Leave this pin open to enable the TR feature. |
| INH/UVLO | 30 | Inhibit and UVLO adjust pin. Use an open drain or open collector logic device to ground this pin to control the INH function. A resistor divider between this pin, AGND, and PVIN/VIN sets the UVLO voltage. |

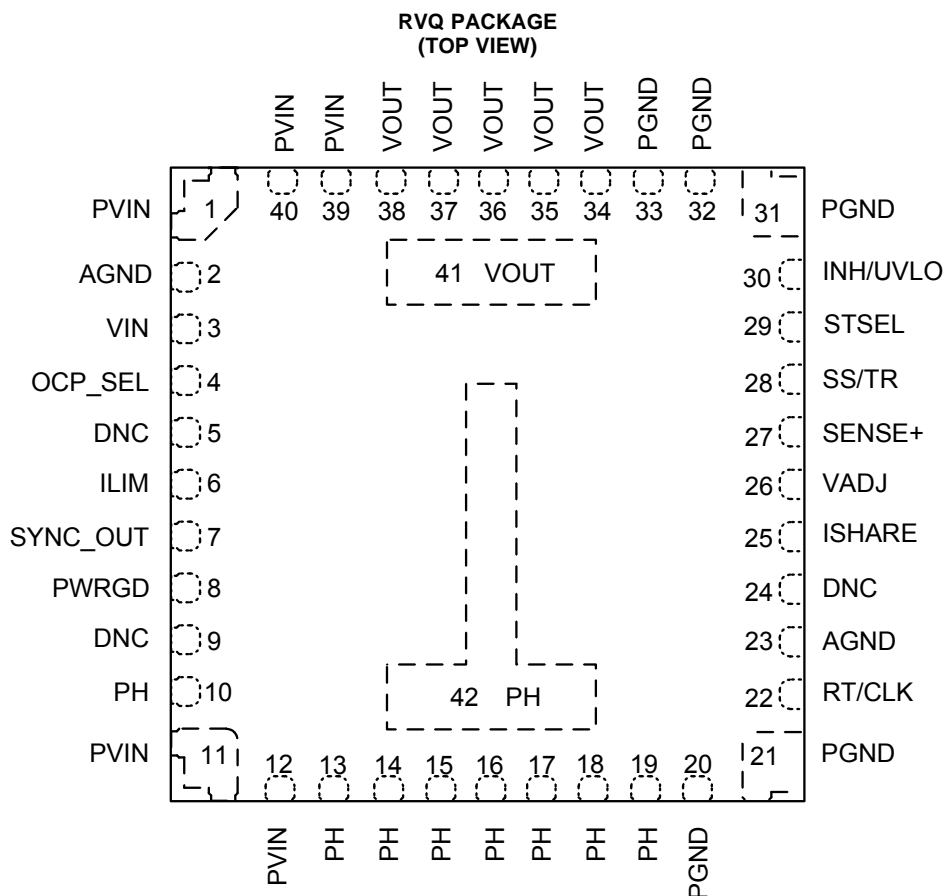

6 Typical Characteristics (P_{VIN} = V_{IN} = 12 V)

The electrical characteristic data has been developed from actual products tested at 25°C. This data is considered typical for the converter. Applies to [Figure 1](#), [Figure 2](#), and [Figure 3](#). The temperature derating curves represent the conditions at which internal components are at or below the manufacturer's maximum operating temperatures. Derating limits apply to devices soldered directly to a 100 mm × 100 mm, 4-layer PCB with 2 oz. copper. Applies to [Figure 4](#).

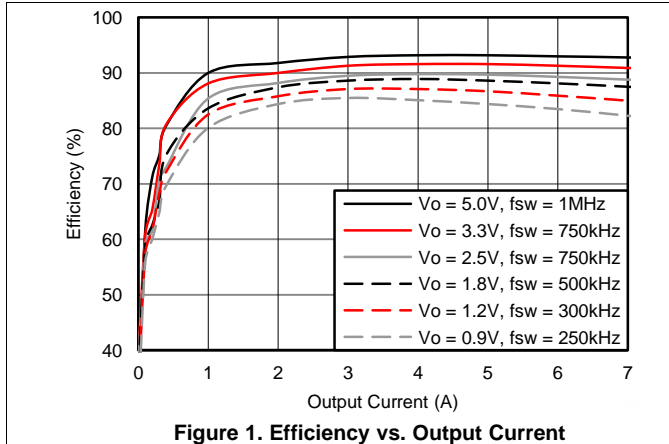

Figure 1. Efficiency vs. Output Current

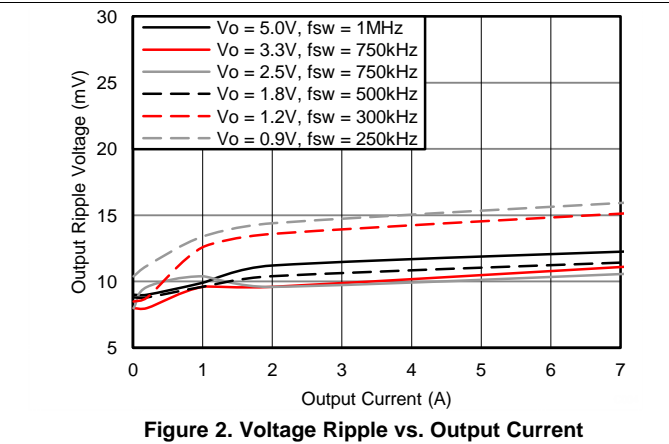

Figure 2. Voltage Ripple vs. Output Current

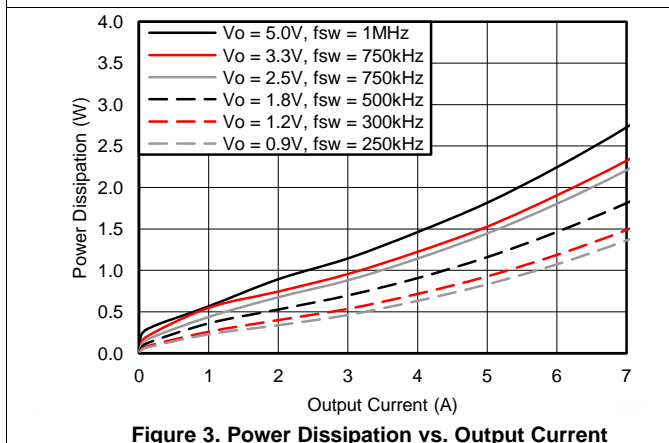

Figure 3. Power Dissipation vs. Output Current

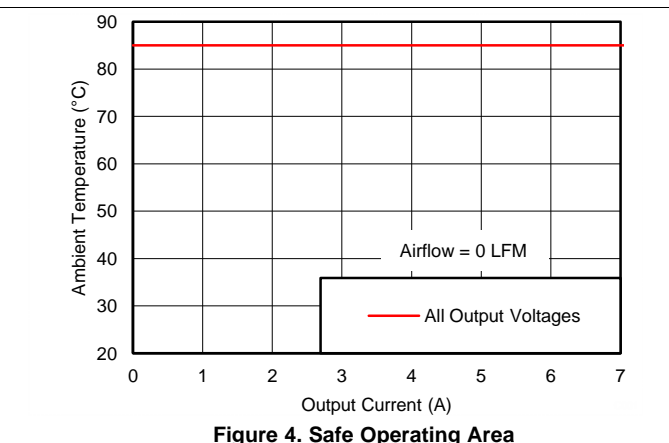

Figure 4. Safe Operating Area

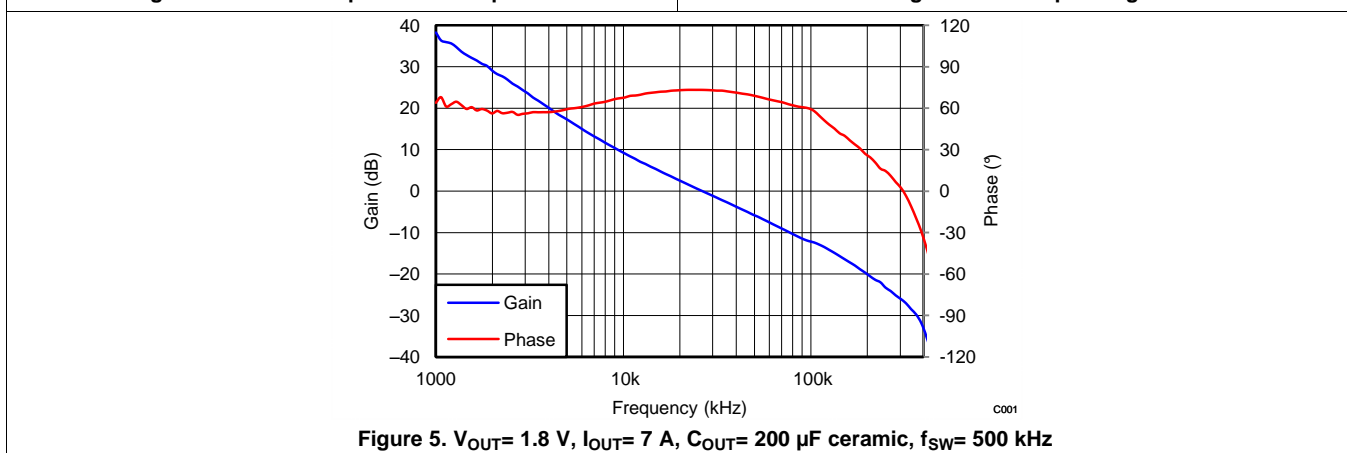

Figure 5. V_{OUT}= 1.8 V, I_{OUT}= 7 A, C_{OUT}= 200 µF ceramic, f_{SW}= 500 kHz

7 Typical Characteristics (P_{VIN} = V_{IN} = 5 V)

The electrical characteristic data has been developed from actual products tested at 25°C. This data is considered typical for the converter. Applies to Figure 6, Figure 7, and Figure 8. The temperature derating curves represent the conditions at which internal components are at or below the manufacturer's maximum operating temperatures. Derating limits apply to devices soldered directly to a 100 mm × 100 mm, 4-layer PCB with 2 oz. copper. Applies to Figure 9.

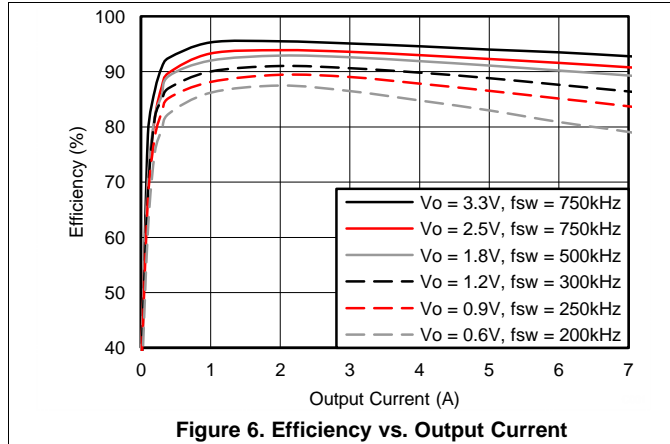

Figure 6. Efficiency vs. Output Current

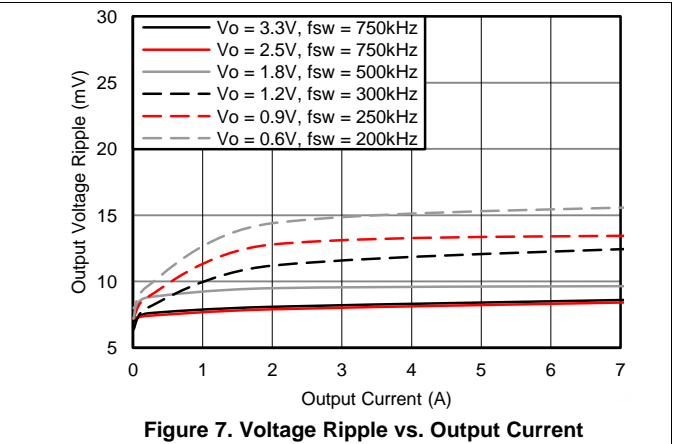

Figure 7. Voltage Ripple vs. Output Current

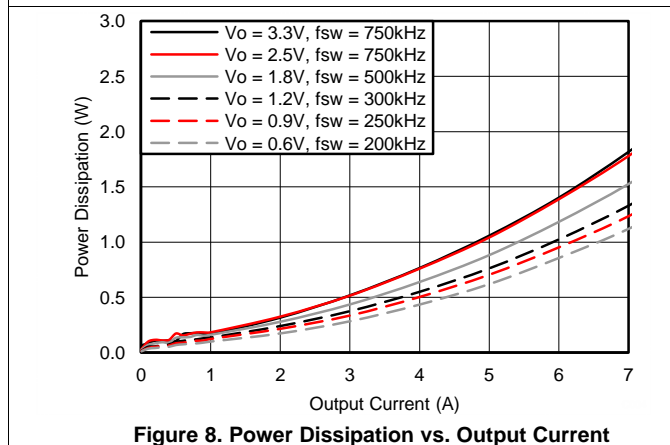

Figure 8. Power Dissipation vs. Output Current

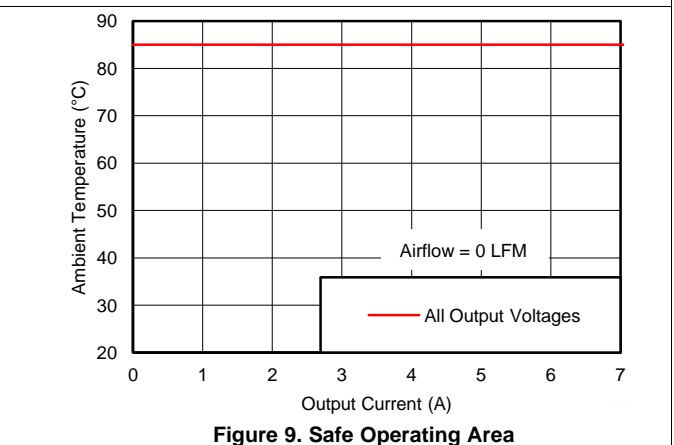

Figure 9. Safe Operating Area

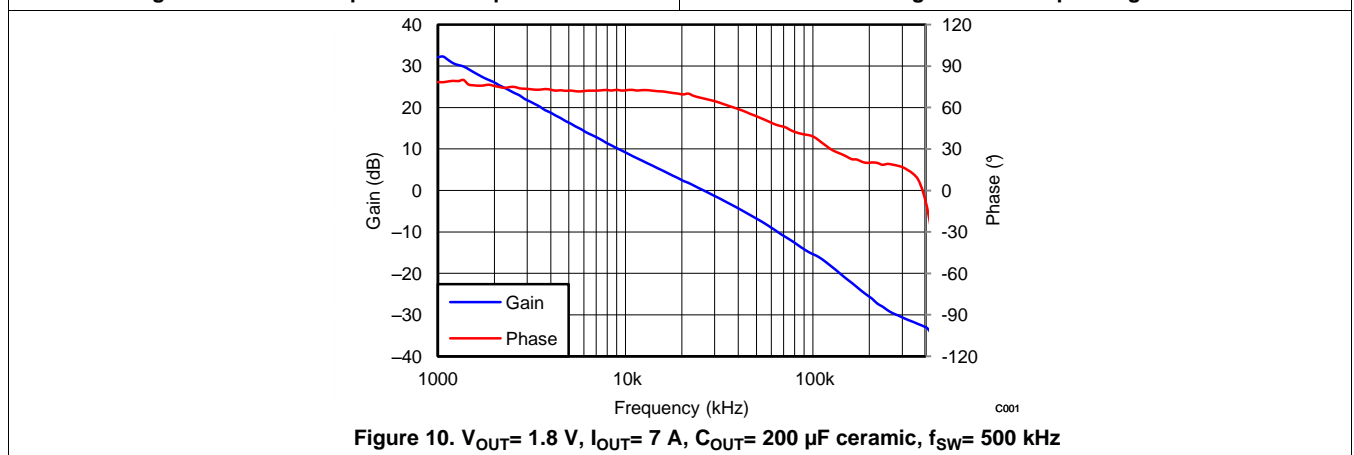

Figure 10. V_{OUT} = 1.8 V, I_{OUT} = 7 A, C_{OUT} = 200 μF ceramic, f_{sw} = 500 kHz

8 Typical Characteristics (PVIN = 3.3 V, VIN = 5 V)

The electrical characteristic data has been developed from actual products tested at 25°C. This data is considered typical for the converter. Applies to [Figure 11](#), [Figure 12](#), and [Figure 13](#). The temperature derating curves represent the conditions at which internal components are at or below the manufacturer's maximum operating temperatures. Derating limits apply to devices soldered directly to a 100 mm x 100 mm, 4-layer PCB with 2 oz. copper. Applies to [Figure 14](#).

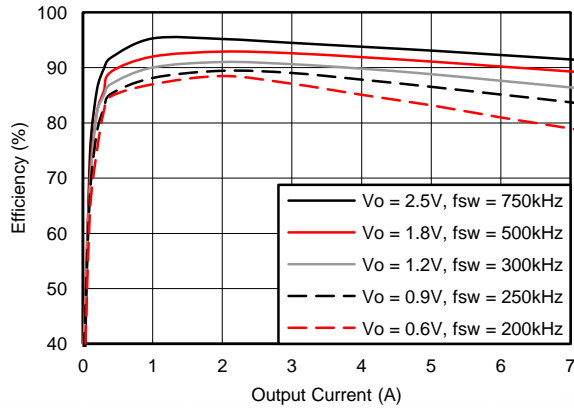

Figure 11. Efficiency vs. Output Current

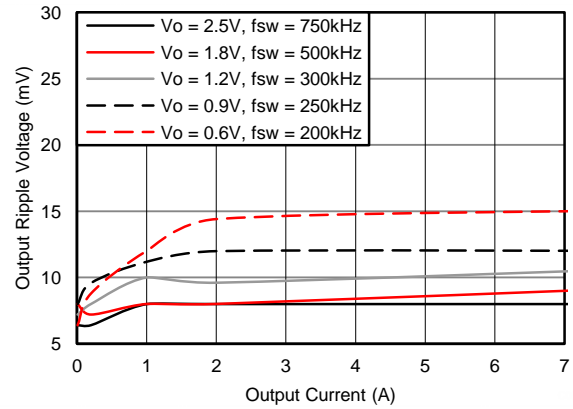

Figure 12. Voltage Ripple vs. Output Current

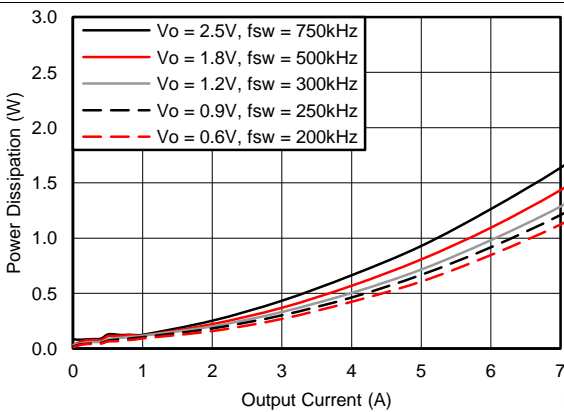

Figure 13. Power Dissipation vs. Output Current

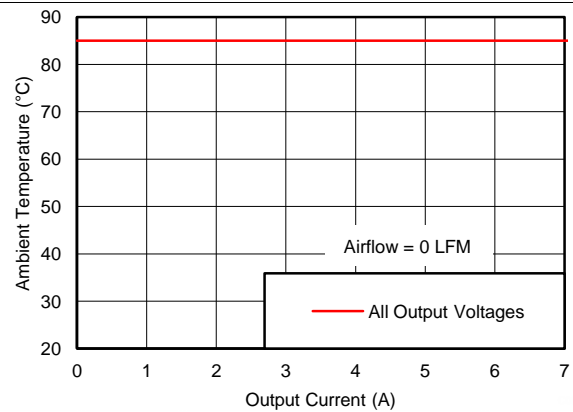

Figure 14. Safe Operating Area

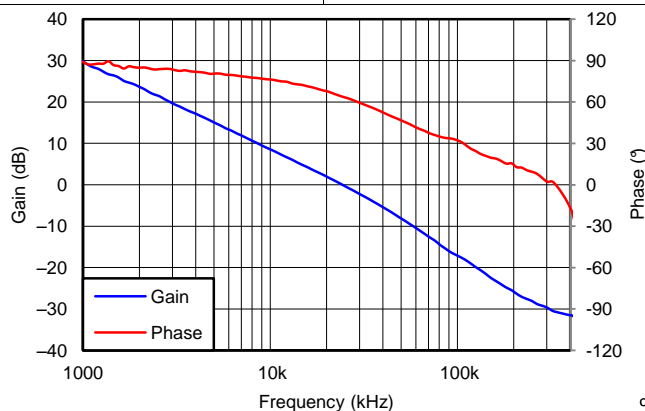

Figure 15. $V_{OUT} = 1.8\text{ V}$, $I_{OUT} = 7\text{ A}$, $C_{OUT} = 200\text{ }\mu\text{F}$ ceramic, $f_{SW} = 500\text{ kHz}$

9 Application Information

9.1 Adjusting the Output Voltage

The VADJ control sets the output voltage of the LMZ31707. The output voltage adjustment range is from 0.6V to 5.5V. The adjustment method requires the addition of R_{SET}, which sets the output voltage, the connection of SENSE+ to VOUT, and in some cases R_{RT} which sets the switching frequency. The R_{SET} resistor must be connected directly between the VADJ (pin 26) and AGND (pin 23). The SENSE+ pin (pin 27) must be connected to VOUT either at the load for improved regulation or at VOUT of the device. The R_{RT} resistor must be connected directly between the RT/CLK (pin 22) and AGND (pin 23). [Table 1](#) gives the standard external R_{SET} resistor for a number of common bus voltages, along with the recommended R_{RT} resistor for that output voltage.

Table 1. Standard R_{SET} Resistor Values for Common Output Voltages

| RESISTORS | OUTPUT VOLTAGE V _{OUT} (V) | | | | | | |
|-----------------------|-------------------------------------|------|------|-------|-------|-------|-------|
| | 0.9 | 1.0 | 1.2 | 1.8 | 2.5 | 3.3 | 5.0 |
| R _{SET} (kΩ) | 2.87 | 2.15 | 1.43 | 0.715 | 0.453 | 0.316 | 0.196 |
| R _{RT} (kΩ) | 1000 | 1000 | 487 | 169 | 90.9 | 90.9 | 63.4 |

For other output voltages, the value of the required resistor can either be calculated using the following formula, or simply selected from the range of values given in [Table 2](#).

$$R_{SET} = \frac{1.43}{\left(\left(\frac{V_{OUT}}{0.6}\right) - 1\right)} \text{ (k}\Omega\text{)} \quad (1)$$

Table 2. Standard R_{SET} Resistor Values

| V _{OUT} (V) | R _{SET} (kΩ) | R _{RT} (kΩ) | f _{sw} (kHz) | V _{OUT} (V) | R _{SET} (kΩ) | R _{RT} (kΩ) | f _{sw} (kHz) |
|----------------------|-----------------------|----------------------|-----------------------|----------------------|-----------------------|----------------------|-----------------------|
| 0.6 | open | OPEN | 200 | 3.1 | 0.348 | 90.9 | 750 |
| 0.7 | 8.66 | OPEN | 200 | 3.2 | 0.332 | 90.9 | 750 |
| 0.8 | 4.32 | OPEN | 200 | 3.3 | 0.316 | 90.9 | 750 |
| 0.9 | 2.87 | 1000 | 250 | 3.4 | 0.309 | 90.9 | 750 |
| 1.0 | 2.15 | 1000 | 250 | 3.5 | 0.294 | 90.9 | 750 |
| 1.1 | 1.74 | 1000 | 250 | 3.6 | 0.287 | 90.9 | 750 |
| 1.2 | 1.43 | 487 | 300 | 3.7 | 0.280 | 90.9 | 750 |
| 1.3 | 1.24 | 487 | 300 | 3.8 | 0.267 | 90.9 | 750 |
| 1.4 | 1.07 | 487 | 300 | 3.9 | 0.261 | 90.9 | 750 |
| 1.5 | 0.953 | 487 | 300 | 4.0 | 0.255 | 90.9 | 750 |
| 1.6 | 0.866 | 487 | 300 | 4.1 | 0.243 | 63.4 | 1000 |
| 1.7 | 0.787 | 487 | 300 | 4.2 | 0.237 | 63.4 | 1000 |
| 1.8 | 0.715 | 169 | 500 | 4.3 | 0.232 | 63.4 | 1000 |
| 1.9 | 0.665 | 169 | 500 | 4.4 | 0.226 | 63.4 | 1000 |
| 2.0 | 0.619 | 169 | 500 | 4.5 | 0.221 | 63.4 | 1000 |
| 2.1 | 0.576 | 169 | 500 | 4.6 | 0.215 | 63.4 | 1000 |
| 2.2 | 0.536 | 169 | 500 | 4.7 | 0.210 | 63.4 | 1000 |
| 2.3 | 0.511 | 169 | 500 | 4.8 | 0.205 | 63.4 | 1000 |
| 2.4 | 0.475 | 169 | 500 | 4.9 | 0.200 | 63.4 | 1000 |
| 2.5 | 0.453 | 90.9 | 750 | 5.0 | 0.196 | 63.4 | 1000 |
| 2.6 | 0.432 | 90.9 | 750 | 5.1 | 0.191 | 63.4 | 1000 |
| 2.7 | 0.412 | 90.9 | 750 | 5.2 | 0.187 | 63.4 | 1000 |
| 2.8 | 0.392 | 90.9 | 750 | 5.3 | 0.182 | 63.4 | 1000 |
| 2.9 | 0.374 | 90.9 | 750 | 5.4 | 0.178 | 63.4 | 1000 |
| 3.0 | 0.357 | 90.9 | 750 | 5.5 | 0.174 | 63.4 | 1000 |

9.2 Capacitor Recommendations for the LMZ31707 Power Supply

9.2.1 Capacitor Technologies

9.2.1.1 Electrolytic, Polymer-Electrolytic Capacitors

When using electrolytic capacitors, high-quality, computer-grade electrolytic capacitors are recommended. Polymer-electrolytic type capacitors are recommended for applications where the ambient operating temperature is less than 0°C. The Sanyo OS-CON capacitor series is suggested due to the lower ESR, higher rated surge, power dissipation, ripple current capability, and small package size. Aluminum electrolytic capacitors provide adequate decoupling over the frequency range of 2 kHz to 150 kHz, and are suitable when ambient temperatures are above 0°C.

9.2.1.2 Ceramic Capacitors

The performance of aluminum electrolytic capacitors is less effective than ceramic capacitors above 150 kHz. Multilayer ceramic capacitors have a low ESR and a resonant frequency higher than the bandwidth of the regulator. They can be used to reduce the reflected ripple current at the input as well as improve the transient response of the output.

9.2.1.3 Tantalum, Polymer-Tantalum Capacitors

Polymer-tantalum type capacitors are recommended for applications where the ambient operating temperature is less than 0°C. The Sanyo POSCAP series and Kemet T530 capacitor series are recommended rather than many other tantalum types due to their lower ESR, higher rated surge, power dissipation, ripple current capability, and small package size. Tantalum capacitors that have no stated ESR or surge current rating are not recommended for power applications.

9.2.2 Input Capacitor

The LMZ31707 requires a minimum input capacitance of 44 μF of ceramic type. An additional 100 μF of non-ceramic capacitance is recommended for applications with transient load requirements. The voltage rating of input capacitors must be greater than the maximum input voltage. At worst case, when operating at 50% duty cycle and maximum load, the combined ripple current rating of the input capacitors must be at least 3.5 Arms. [Table 4](#) includes a preferred list of capacitors by vendor. It is also recommended to place a 0.1 μF ceramic capacitor directly across the PVIN and PGND pins of the device. When operating with split VIN and PVIN rails, place 4.7 μF of ceramic capacitance directly at the VIN pin.

9.2.3 Output Capacitor

The required output capacitance is determined by the output voltage of the LMZ31707. See [Table 3](#) for the amount of required capacitance. The effects of temperature and capacitor voltage rating must be considered when selecting capacitors to meet the minimum required capacitance. The required output capacitance can be comprised of all ceramic capacitors, or a combination of ceramic and bulk capacitors. The required capacitance must include at least one 47 μF ceramic. When adding additional non-ceramic bulk capacitors, low-ESR devices like the ones recommended in [Table 4](#) are required. The required capacitance above the minimum is determined by actual transient deviation requirements. [Table 4](#) includes a preferred list of capacitors by vendor.

Table 3. Required Output Capacitance

| V _{OUT} RANGE (V) | | MINIMUM REQUIRED C _{OUT} (μF) |
|----------------------------|-------|---|
| MIN | MAX | |
| 0.6 | < 0.8 | 500 μF ⁽¹⁾ |
| 0.8 | < 1.2 | 300 μF ⁽¹⁾ |
| 1.2 | < 3.0 | 200 μF ⁽¹⁾ |
| 3.0 | < 4.0 | 100 μF ⁽¹⁾ |
| 4.0 | 5.5 | 47 μF ceramic |

(1) Minimum required must include at least one 47 μF ceramic capacitor.

Table 4. Recommended Input/Output Capacitors⁽¹⁾

| VENDOR | SERIES | PART NUMBER | CAPACITOR CHARACTERISTICS | | |
|-----------|--------|--------------------|---------------------------|------------------|-------------------------|
| | | | WORKING VOLTAGE (V) | CAPACITANCE (μF) | ESR ⁽²⁾ (mΩ) |
| Murata | X5R | GRM32ER61E226K | 25 | 22 | 2 |
| TDK | X5R | C3225X5R0J107M | 6.3 | 100 | 2 |
| TDK | X5R | C3225X5R0J476K | 6.3 | 47 | 2 |
| Murata | X5R | GRM32ER60J107M | 6.3 | 100 | 2 |
| Murata | X5R | GRM32ER60J476M | 6.3 | 47 | 2 |
| Panasonic | EEH-ZA | EEH-ZA1E101XP | 25 | 100 | 30 |
| Sanyo | POSCAP | 16TQC68M | 16 | 68 | 50 |
| Kemet | T520 | T520V107M010ASE025 | 10 | 100 | 25 |
| Sanyo | POSCAP | 10TPE220ML | 10 | 220 | 25 |
| Sanyo | POSCAP | 6TPE100MI | 6.3 | 100 | 25 |
| Sanyo | POSCAP | 2R5TPE220M7 | 2.5 | 220 | 7 |
| Kemet | T530 | T530D227M006ATE006 | 6.3 | 220 | 6 |
| Kemet | T530 | T530D337M006ATE010 | 6.3 | 330 | 10 |
| Sanyo | POSCAP | 2TPF330M6 | 2.0 | 330 | 6 |
| Sanyo | POSCAP | 6TPE330MFL | 6.3 | 330 | 15 |

(1) Capacitor Supplier Verification, RoHS, Lead-free and Material Details

Consult capacitor suppliers regarding availability, material composition, RoHS and lead-free status, and manufacturing process requirements for any capacitors identified in this table.

(2) Maximum ESR @ 100kHz, 25°C.

9.3 Transient Response

Table 5. Output Voltage Transient Response

| C _{IN1} = 3x 22 μF CERAMIC, C _{IN2} = 100 μF POLYMER-TANTALUM | | | | | | |
|---|---------------------|---------------------------|------------------------|-------------------------|---------------------------|--------------------|
| V _{OUT} (V) | V _{IN} (V) | C _{OUT1} Ceramic | C _{OUT2} BULK | VOLTAGE DEVIATION (mV) | | RECOVERY TIME (μs) |
| | | | | 2 A LOAD STEP, (1 A/μs) | 3.5 A LOAD STEP, (1 A/μs) | |
| 0.6 | 5 | 500 μF | 220 μF | 30 | 45 | 90 |
| | 12 | 500 μF | 220 μF | 30 | 45 | 90 |
| 0.9 | 5 | 300 μF | 220 μF | 40 | 65 | 95 |
| | | 300 μF | 470 μF | 35 | 60 | 95 |
| | 12 | 300 μF | 220 μF | 35 | 60 | 95 |
| | | 300 μF | 470 μF | 30 | 55 | 95 |
| 1.2 | 5 | 200 μF | 220 μF | 50 | 85 | 100 |
| | | 200 μF | 470 μF | 45 | 75 | 100 |
| | 12 | 200 μF | 220 μF | 45 | 80 | 100 |
| | | 200 μF | 470 μF | 40 | 70 | 100 |
| 1.8 | 5 | 200 μF | 220 μF | 70 | 105 | 110 |
| | | 200 μF | 470 μF | 65 | 90 | 110 |
| | 12 | 200 μF | 220 μF | 65 | 100 | 120 |
| | | 200 μF | 470 μF | 60 | 90 | 120 |
| 3.3 | 5 | 100 μF | 220 μF | 105 | 177 | 130 |
| | 12 | 100 μF | 220 μF | 115 | 190 | 150 |

9.4 Transient Waveforms

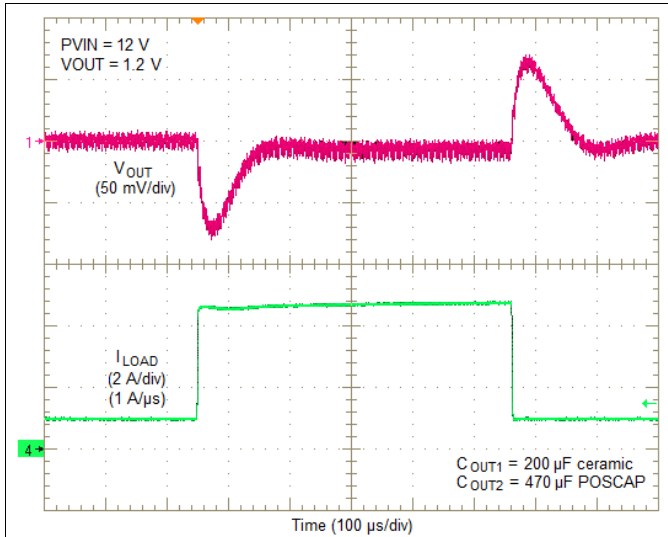

Figure 16. PVIN = 12V, VOUT = 1.2V, 3.5A Load Step

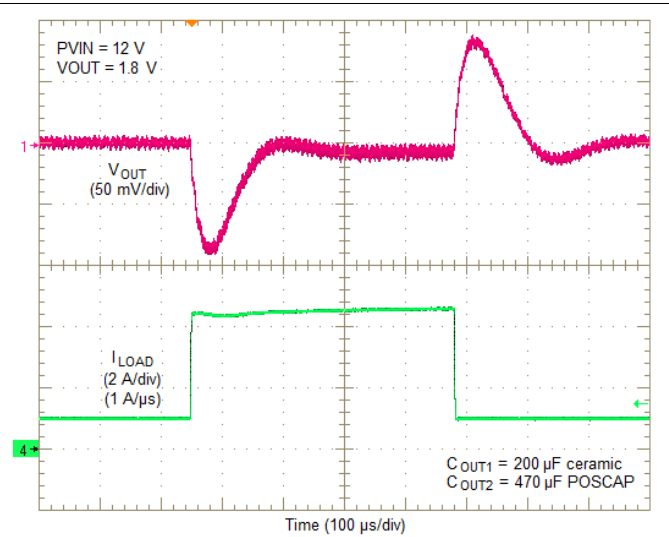

Figure 17. PVIN = 12V, VOUT = 1.8V, 3.5A Load Step

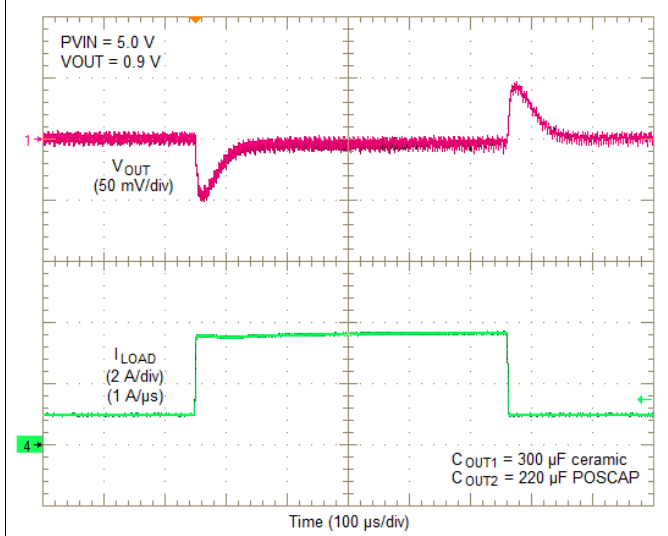

Figure 18. PVIN = 5V, VOUT = 0.9V, 2.5A Load Step

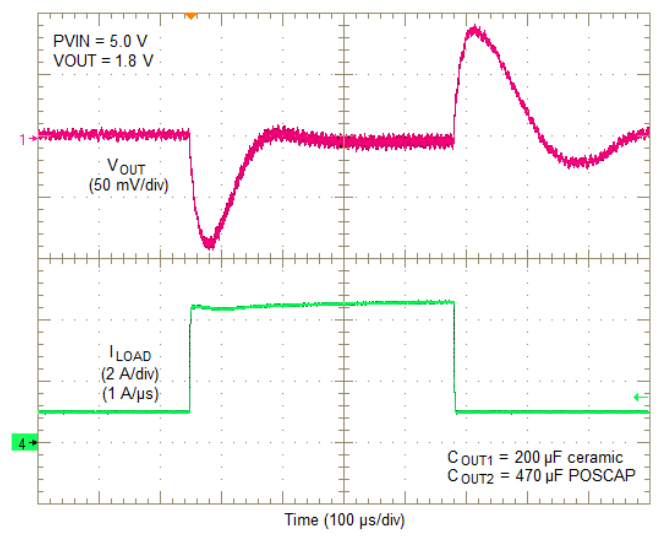

Figure 19. PVIN = 5V, VOUT = 1.8V, 3.5A Load Step

9.5 Application Schematics

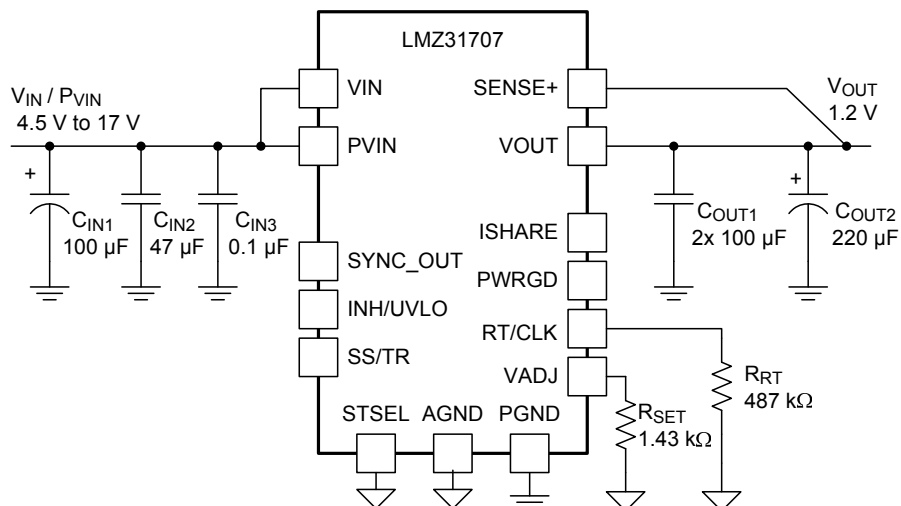

Figure 20. Typical Schematic
PVIN = VIN = 4.5 V to 17 V, VOUT = 1.2 V

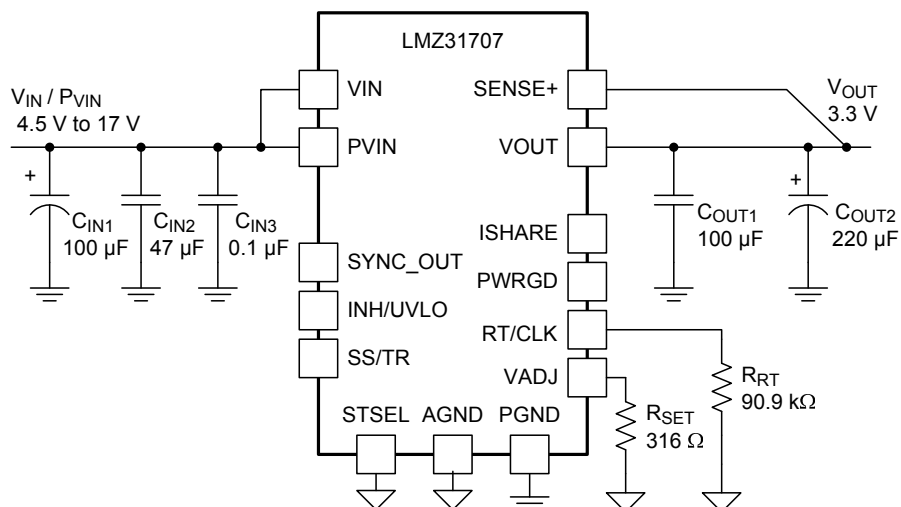

Figure 21. Typical Schematic
PVIN = VIN = 4.5 V to 17 V, VOUT = 3.3 V

Application Schematics (continued)

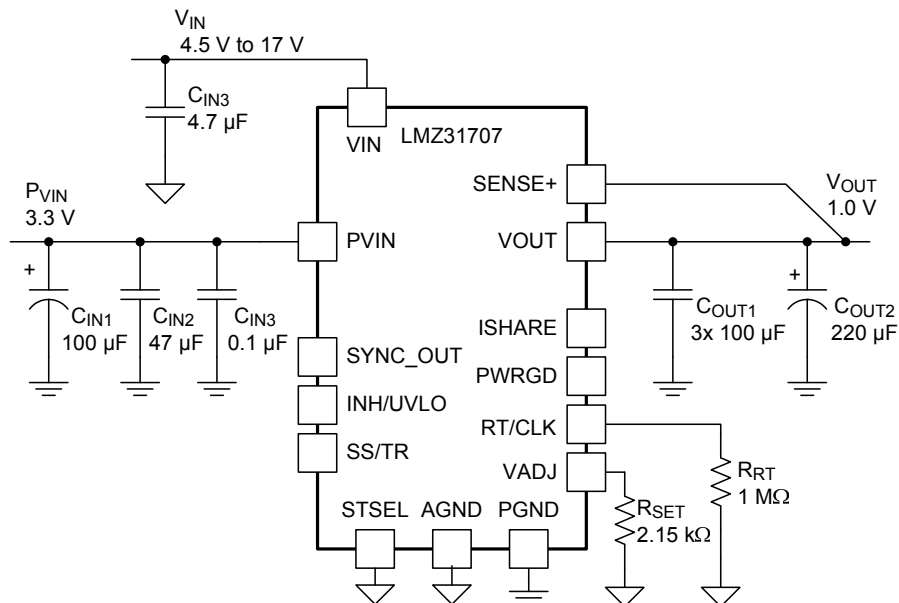

Figure 22. Typical Schematic
PVIN = 3.3 V, VIN = 4.5 V to 17 V, VOUT = 1.0 V

9.6 Custom Design With WEBENCH® Tools

[Click here](#) to create a custom design using the LMZ31707 device with the WEBENCH® Power Designer.

1. Start by entering the input voltage (V_{IN}), output voltage (V_{OUT}), and output current (I_{OUT}) requirements.
2. Optimize the design for key parameters such as efficiency, footprint, and cost using the optimizer dial.
3. Compare the generated design with other possible solutions from Texas Instruments.

The WEBENCH Power Designer provides a customized schematic along with a list of materials with real-time pricing and component availability.

In most cases, these actions are available:

- Run electrical simulations to see important waveforms and circuit performance
- Run thermal simulations to understand board thermal performance
- Export customized schematic and layout into popular CAD formats
- Print PDF reports for the design, and share the design with colleagues

Get more information about WEBENCH tools at www.ti.com/WEBENCH.

9.7 VIN and PVIN Input Voltage

The LMZ31707 allows for a variety of applications by using the VIN and PVIN pins together or separately. The VIN voltage supplies the internal control circuits of the device. The PVIN voltage provides the input voltage to the power converter system.

If tied together, the input voltage for the VIN pin and the PVIN pin can range from 4.5 V to 17 V. If using the VIN pin separately from the PVIN pin, the VIN pin must be greater than 4.5 V, and the PVIN pin can range from as low as 2.95 V to 17 V. When operating from a split rail, it is recommended to supply VIN from 5 V to 12 V, for best performance. A voltage divider connected to the INH/UVLO pin can adjust either input voltage UVLO appropriately. See the [Programmable Undervoltage Lockout \(UVLO\)](#) section of this datasheet for more information.

9.8 3.3 V PVIN Operation

Applications operating from a PVIN of 3.3 V must provide at least 4.5 V for VIN. It is recommended to supply VIN from 5 V to 12 V, for best performance. See listeraure number [SNVA692](#) for help creating 5 V from 3.3 V using a small, simple charge pump device.

9.9 Power Good (PWRGD)

The PWRGD pin is an open drain output. Once the voltage on the SENSE+ pin is between 95% and 104% of the set voltage, the PWRGD pin pull-down is released and the pin floats. The recommended pull-up resistor value is between 10 kΩ and 100 kΩ to a voltage source that is 5.5 V or less. The PWRGD pin is in a defined state once VIN is greater than 1.0 V, but with reduced current sinking capability. The PWRGD pin achieves full current sinking capability once the VIN pin is above 4.5V. The PWRGD pin is pulled low when the voltage on SENSE+ is lower than 91% or greater than 108% of the nominal set voltage. Also, the PWRGD pin is pulled low if the input UVLO or thermal shutdown is asserted, the INH pin is pulled low, or the SS/TR pin is below 1.4 V.

9.10 SYNC_OUT

The LMZ31707 provides a 180° out-of-phase clock signal for applications requiring synchronization. The SYNC_OUT pin produces a 50% duty cycle clock signal that is the same frequency as the device's switching frequency, but is 180° out of phase. Operating two devices 180° out of phase reduces input and output voltage ripple. The SYNC_OUT clock signal is compatible with other LMZ3 devices that have a CLK input.

9.11 Parallel Operation

Up to six LMZ31707 devices can be paralleled for increased output current. Multiple connections must be made between the paralleled devices and the component selection is slightly different than for a stand-alone LMZ31707 device. A typical LMZ31707 parallel schematic is shown in [Figure 23](#). Refer to application note, [SNVA695](#) for information and design help when paralleling multiple LMZ31707 devices.

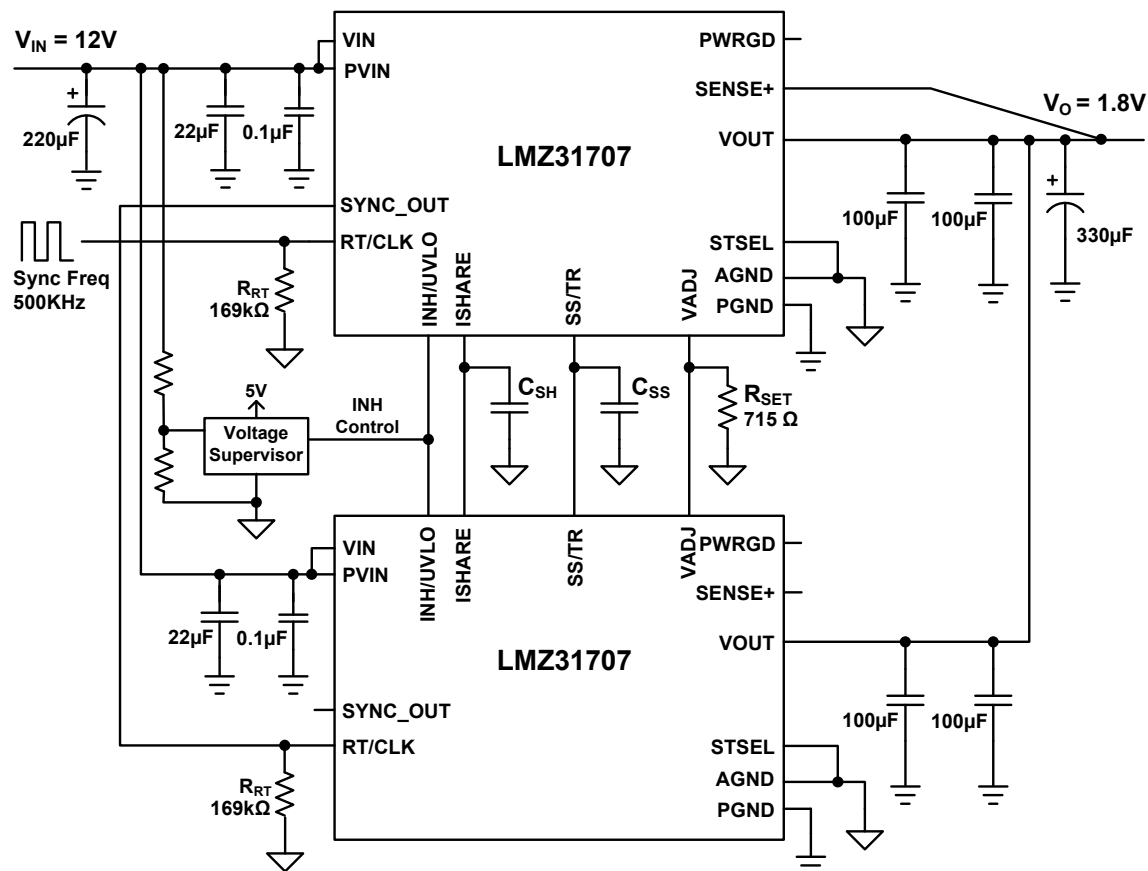

Figure 23. Typical LMZ31707 Parallel Schematic

9.12 Light Load Efficiency (LLE)

The LMZ31707 operates in pulse skip mode at light load currents to improve efficiency and decrease power dissipation by reducing switching and gate drive losses.

These pulses may cause the output voltage to rise when there is no load to discharge the energy. For output voltages < 1.5 V, a minimum load is required. The amount of required load can be determined by [Equation 2](#). In most cases the minimum current drawn by the load circuit will be enough to satisfy this load. Applications requiring a load resistor to meet the minimum load, the added power dissipation will be ≤ 3.6 mW. A single 0402 size resistor across VOUT and PGND can be used.

$$I_{\text{MIN}} = 600 \mu\text{A} - \left(\frac{V_{\text{OUT}}}{1.43\text{k} + R_{\text{SET}}} \right) (\text{A}) \quad (2)$$

When $V_{\text{OUT}} = 0.6$ V and $R_{\text{SET}} = \text{OPEN}$, the minimum load current is 600 μA .

9.13 Power-Up Characteristics

When configured as shown in the front page schematic, the LMZ31707 produces a regulated output voltage following the application of a valid input voltage. During the power-up, internal soft-start circuitry slows the rate that the output voltage rises, thereby limiting the amount of in-rush current that can be drawn from the input source. [Figure 24](#) shows the start-up waveforms for a LMZ31707, operating from a 5-V input ($P_{\text{VIN}} = \text{VIN}$) and with the output voltage adjusted to 1.8 V. [Figure 25](#) shows the start-up waveforms for a LMZ31707 starting up into a pre-biased output voltage. The waveforms were measured with a 5-A constant current load.

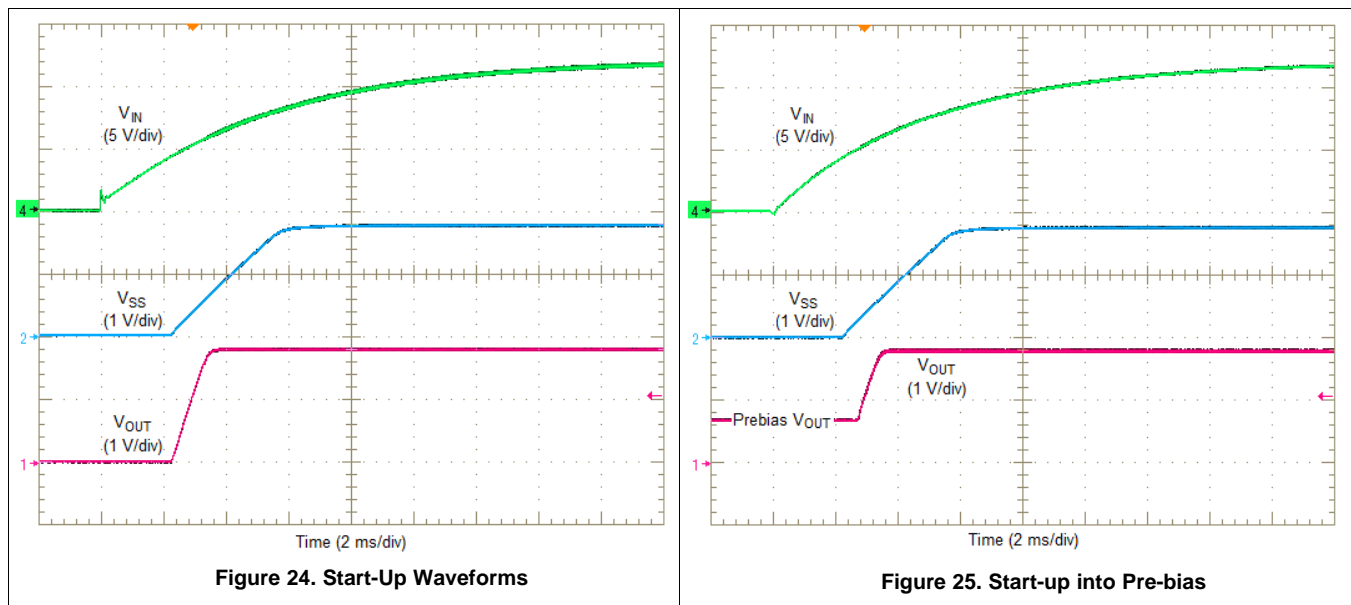

9.14 Pre-Biased Start-Up

The LMZ31707 has been designed to prevent the low-side MOSFET from discharging a pre-biased output. During pre-biased startup, the low-side MOSFET does not turn on until the high-side MOSFET has started switching. The high-side MOSFET does not start switching until the slow start voltage exceeds the voltage on the VADJ pin. Refer to [Figure 25](#).

9.15 Remote Sense

The SENSE+ pin must be connected to V_{OUT} at the load, or at the device pins.

Connecting the SENSE+ pin to V_{OUT} at the load improves the load regulation performance of the device by allowing it to compensate for any I-R voltage drop between its output pins and the load. An I-R drop is caused by the high output current flowing through the small amount of pin and trace resistance. This should be limited to a maximum of 300 mV.

NOTE

The remote sense feature is not designed to compensate for the forward drop of nonlinear or frequency dependent components that may be placed in series with the converter output. Examples include OR-ing diodes, filter inductors, ferrite beads, and fuses. When these components are enclosed by the SENSE+ connection, they are effectively placed inside the regulation control loop, which can adversely affect the stability of the regulator.

9.16 Thermal Shutdown

The internal thermal shutdown circuitry forces the device to stop switching if the junction temperature exceeds 175°C typically. The device reinitiates the power up sequence when the junction temperature drops below 165°C typically.

9.17 Output On/Off Inhibit (INH)

The INH pin provides electrical on/off control of the device. Once the INH pin voltage exceeds the threshold voltage, the device starts operation. If the INH pin voltage is pulled below the threshold voltage, the regulator stops switching and enters low quiescent current state. The INH pin has an internal pull-up current source, allowing the user to float the INH pin for enabling the device.

If an application requires controlling the INH pin, use an open drain/collector device, or a suitable logic gate to interface with the pin. Using a voltage supervisor to control the INH pin allows control of the turn-on and turn-off of the device as opposed to relying on the ramp up or down if the input voltage source.

Figure 26 shows the typical application of the inhibit function. Turning Q1 on applies a low voltage to the inhibit control (INH) pin and disables the output of the supply, shown in Figure 27. If Q1 is turned off, the supply executes a soft-start power-up sequence, as shown in Figure 28. A regulated output voltage is produced within 2 ms. The waveforms were measured with a 5-A constant current load.

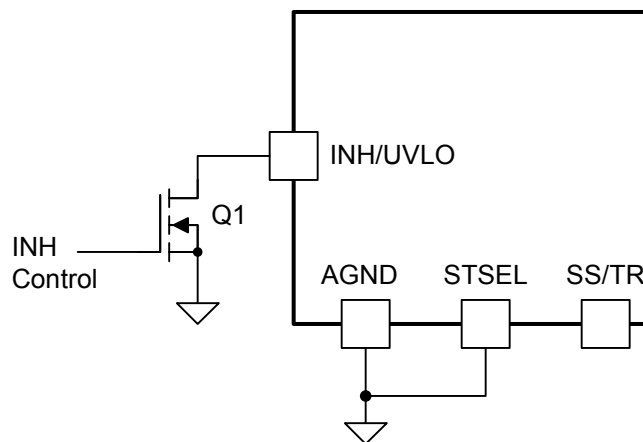
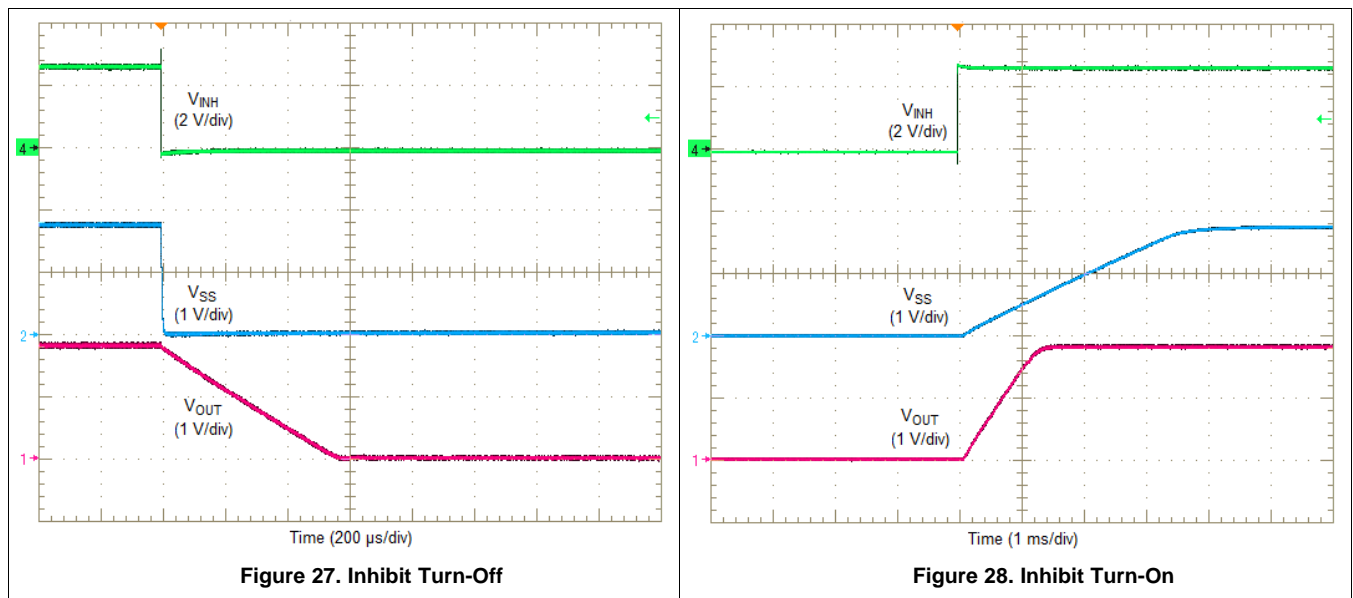

Figure 26. Typical Inhibit Control



9.18 Slow Start (SS/TR)

Connecting the STSEL pin to AGND and leaving SS/TR pin open enables the internal SS capacitor with a slow start interval of approximately 1.2 ms. Adding additional capacitance between the SS pin and AGND increases the slow start time. Increasing the slow start time will reduce inrush current seen by the input source and reduce the current seen by the device when charging the output capacitors. To avoid the activation of current limit and ensure proper start-up, the SS capacitor may need to be increased when operating near the maximum output capacitance limit.

Figure 29 shows an additional SS capacitor connected to the SS/TR pin and the STSEL pin connected to AGND. See Table 6 below for SS capacitor values and timing interval.

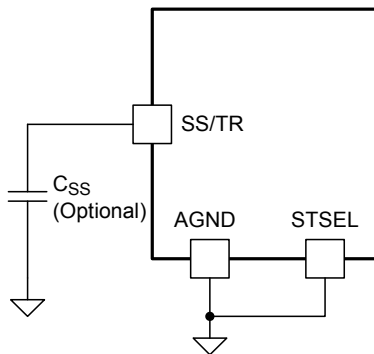

Figure 29. Slow-Start Capacitor (C_{SS}) and STSEL Connection

Table 6. Slow-Start Capacitor Values and Slow-Start Time

| C _{SS} (nF) | open | 3.3 | 4.7 | 10 | 15 | 22 | 33 |
|----------------------|------|-----|-----|-----|-----|-----|-----|
| SS Time (msec) | 1.2 | 2.1 | 2.5 | 3.8 | 5.1 | 7.0 | 9.8 |

9.19 Overcurrent Protection

For protection against load faults, the LMZ31707 incorporates output overcurrent protection. The overcurrent protection mode can be selected using the OCP_SEL pin. Leaving the OCP_SEL pin open selects hiccup mode and connecting it to AGND selects cycle-by-cycle mode. In hiccup mode, applying a load that exceeds the regulator's overcurrent threshold causes the regulated output to shut down. Following shutdown, the module periodically attempts to recover by initiating a soft-start power-up as shown in Figure 30. This is described as a hiccup mode of operation, whereby the module continues in a cycle of successive shutdown and power up until the load fault is removed. During this period, the average current flowing into the fault is significantly reduced which reduces power dissipation. Once the fault is removed, the module automatically recovers and returns to normal operation as shown in Figure 31.

In cycle-by-cycle mode, applying a load that exceeds the regulator's overcurrent threshold limits the output current and reduces the output voltage as shown in Figure 32. During this period, the current flowing into the fault remains high causing the power dissipation to stay high as well. Once the overcurrent condition is removed, the output voltage returns to the set-point voltage as shown in Figure 33.

Overcurrent Protection (continued)

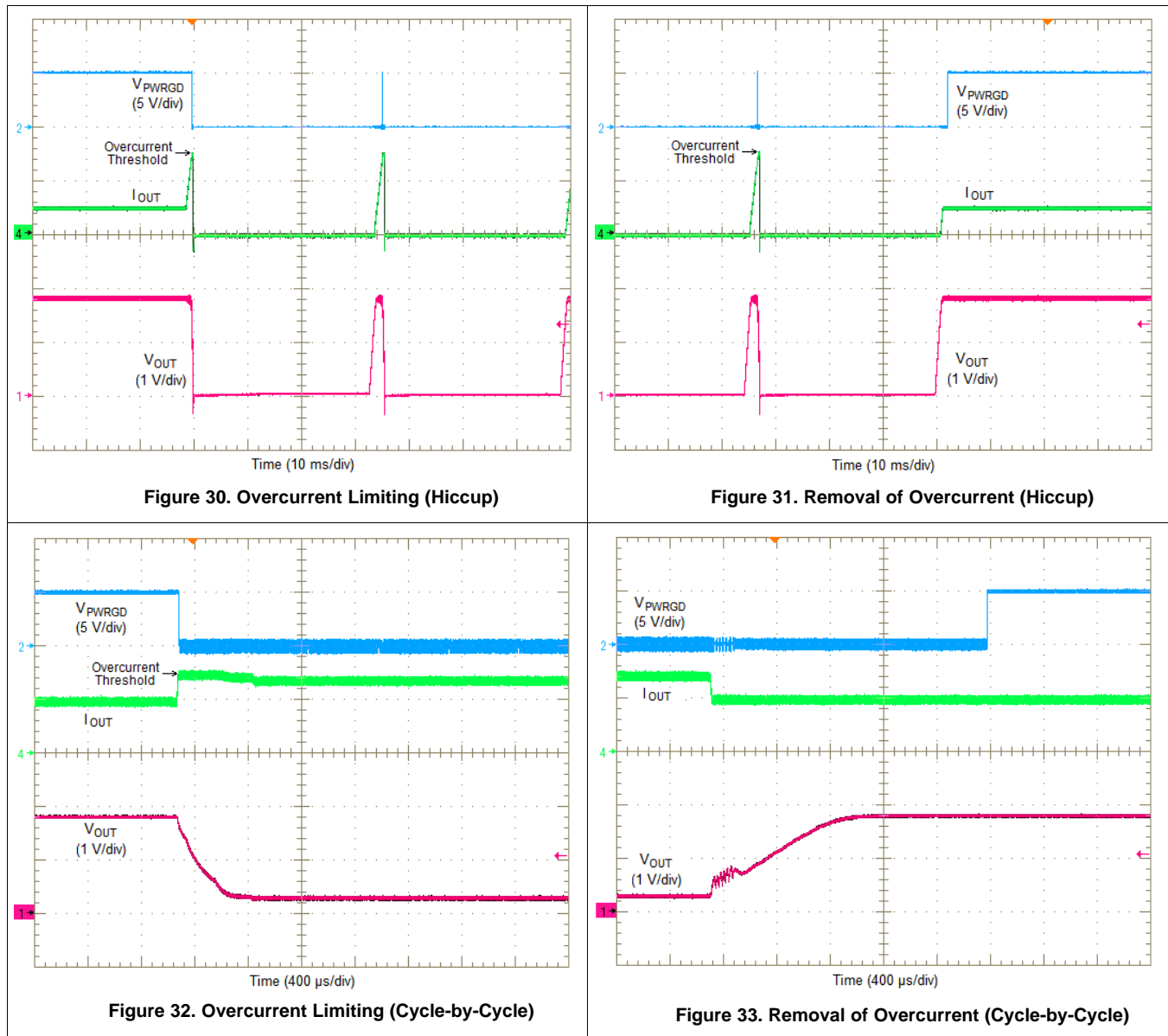

9.20 Synchronization (CLK)

An internal phase locked loop (PLL) has been implemented to allow synchronization between 200 kHz and 1200 kHz, and to easily switch from RT mode to CLK mode. To implement the synchronization feature, connect a square wave clock signal to the RT/CLK pin with a duty cycle between 20% to 80%. The clock signal amplitude must transition lower than 0.5 V and higher than 2.0 V. The start of the switching cycle is synchronized to the falling edge of RT/CLK pin. In applications where both RT mode and CLK mode are needed, the device can be configured as shown in [Figure 34](#).

Before the external clock is present, the device works in RT mode and the switching frequency is set by RT resistor. When the external clock is present, the CLK mode overrides the RT mode. The first time the CLK pin is pulled above the RT/CLK high threshold (2.0 V), the device switches from RT mode to CLK mode and the RT/CLK pin becomes high impedance as the PLL starts to lock onto the frequency of the external clock. It is not recommended to switch from CLK mode back to RT mode because the internal switching frequency drops to 100 kHz first before returning to the switching frequency set by the RT resistor (R_{RT}).

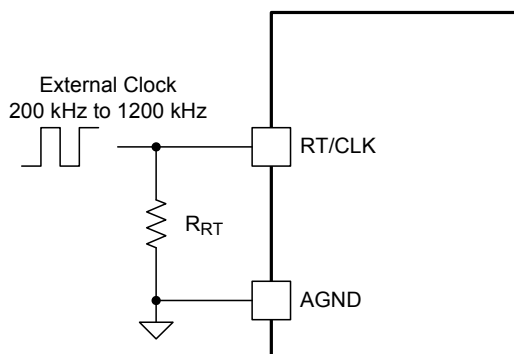

Figure 34. RT/CLK Configuration

The synchronization frequency must be selected based on the output voltages of the devices being synchronized. [Table 7](#) shows the allowable frequencies for a given range of output voltages. For the most efficient solution, always synchronize to the lowest allowable frequency. For example, an application requires synchronizing three LMZ31707 devices with output voltages of 1.0 V, 1.2 V and 1.8 V, all powered from $P_{VIN} = 12$ V. [Table 7](#) shows that all three output voltages should be synchronized to 300 kHz.

Table 7. Synchronization Frequency vs Output Voltage

| SYNCHRONIZATION FREQUENCY (kHz) | P _{VIN} = 12 V | | P _{VIN} = 5 V | |
|------------------------------------|----------------------------|-----|----------------------------|-----|
| | V _{OUT} RANGE (V) | | V _{OUT} RANGE (V) | |
| | MIN | MAX | MIN | MAX |
| 200 | 0.6 | 1.3 | 0.6 | 1.5 |
| 300 | 0.8 | 2.0 | 0.6 | 4.3 |
| 400 | 1.1 | 2.5 | 0.6 | 4.3 |
| 500 | 1.4 | 3.4 | 0.6 | 4.3 |
| 600 | 1.6 | 5.0 | 0.7 | 4.3 |
| 700 | 1.9 | 5.5 | 0.8 | 4.3 |
| 800 | 2.1 | 5.5 | 0.9 | 4.3 |
| 900 | 2.4 | 5.5 | 1.0 | 4.3 |
| 1000 | 2.7 | 5.5 | 1.1 | 4.3 |
| 1100 | 2.9 | 5.5 | 1.3 | 4.3 |
| 1200 | 3.2 | 5.5 | 1.4 | 4.3 |

9.21 Sequencing (SS/TR)

Many of the common power supply sequencing methods can be implemented using the SS/TR, INH and PWRGD pins. The sequential method is illustrated in Figure 35 using two LMZ31707 devices. The PWRGD pin of the first device is coupled to the INH pin of the second device which enables the second power supply once the primary supply reaches regulation. Figure 36 shows sequential turn-on waveforms of two LMZ31707 devices.

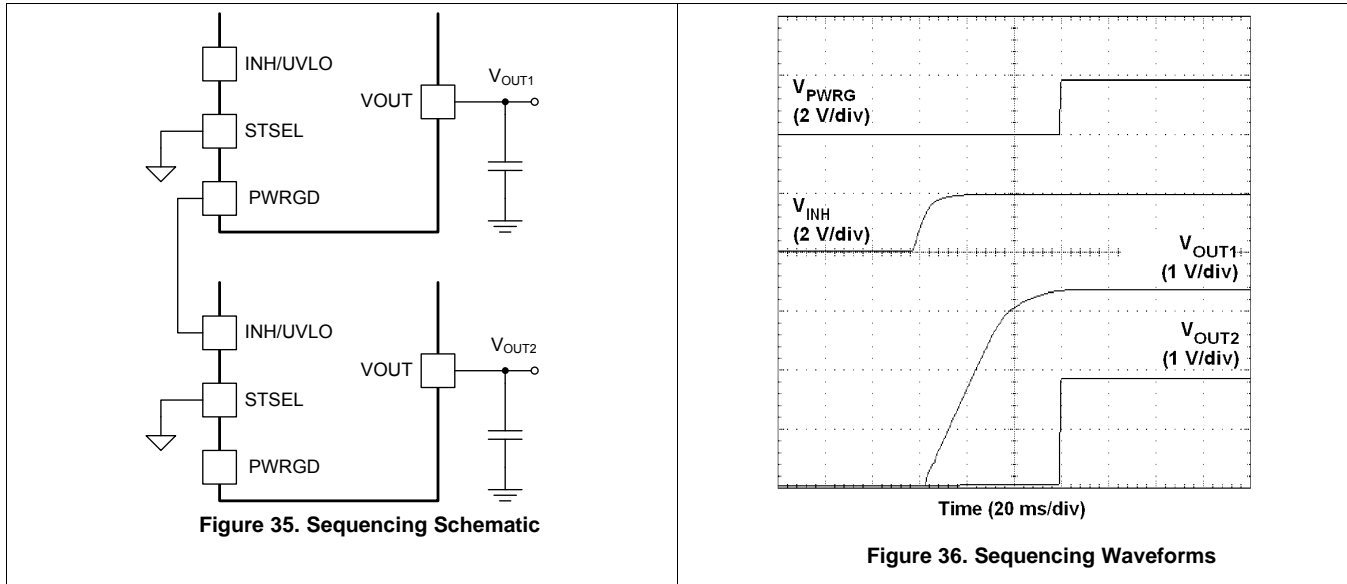

Simultaneous power supply sequencing can be implemented by connecting the resistor network of R1 and R2 shown in Figure 37 to the output of the power supply that needs to be tracked or to another voltage reference source. The tracking voltage must exceed 750mV before V_{OUT2} reaches its set-point voltage. The PWRGD output of the V_{OUT2} device may remain low if the tracking voltage does not exceed 1.4V. Figure 38 shows simultaneous turn-on waveforms of two LMZ31707 devices. Use Equation 3 and Equation 4 to calculate the values of R1 and R2.

$$R1 = \frac{(V_{OUT2} \times 12.6)}{0.6} \text{ (k}\Omega\text{)} \tag{3}$$

$$R2 = \frac{0.6 \times R1}{(V_{OUT2} - 0.6)} \text{ (k}\Omega\text{)} \tag{4}$$

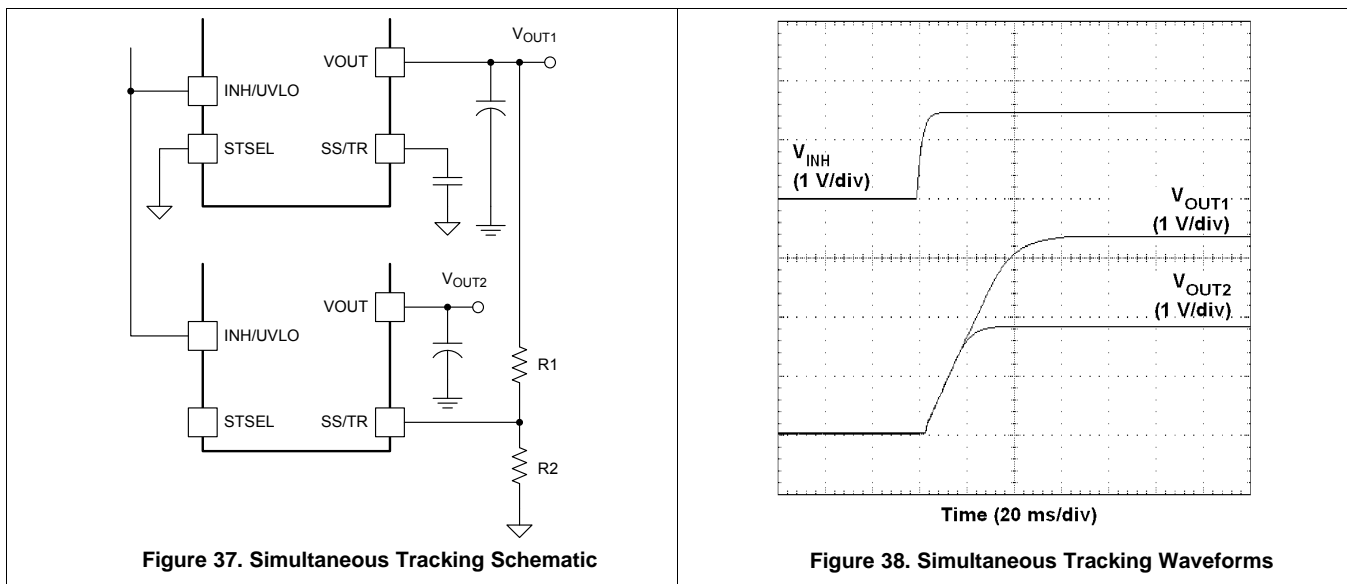

9.22 Programmable Undervoltage Lockout (UVLO)

The LMZ31707 implements internal UVLO circuitry on the VIN pin. The device is disabled when the VIN pin voltage falls below the internal VIN UVLO threshold. The internal VIN UVLO rising threshold is 4.5 V(max) with a typical hysteresis of 150 mV.

If an application requires either a higher UVLO threshold on the VIN pin or a higher UVLO threshold for a combined VIN and PVIN, then the UVLO pin can be configured as shown in Figure 39 or Figure 40. Table 8 lists standard values for R_{UVLO1} and R_{UVLO2} to adjust the VIN UVLO voltage up.

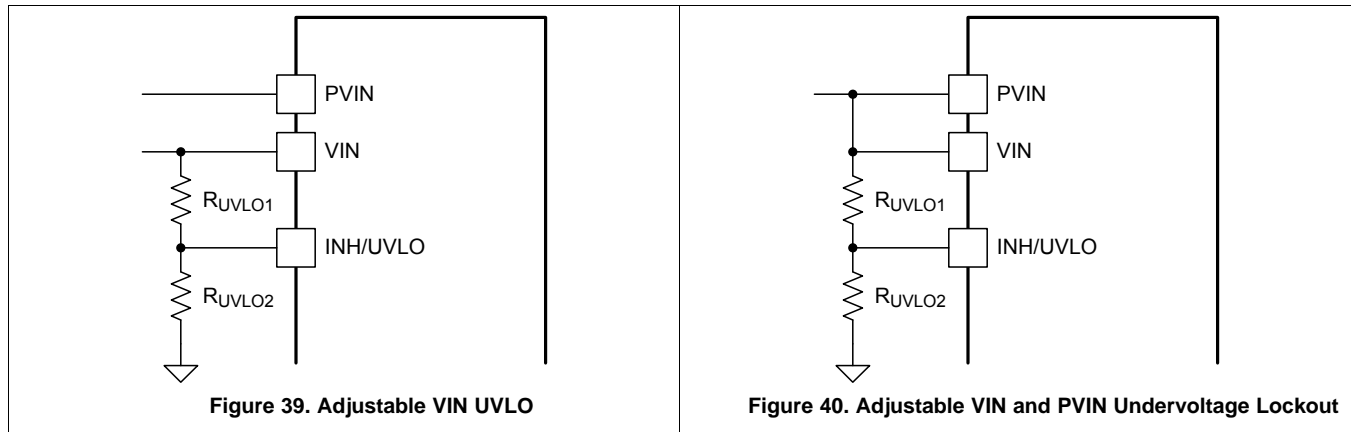

Table 8. Standard Resistor values for Adjusting VIN UVLO

| VIN UVLO (V) | 5.0 | 5.5 | 6.0 | 6.5 | 7.0 | 7.5 | 8.0 | 8.5 | 9.0 | 9.5 | 10.0 |
|---------------------------|------|------|------|------|------|------|------|------|------|------|------|
| R_{UVLO1} (k Ω) | 68.1 | 68.1 | 68.1 | 68.1 | 68.1 | 68.1 | 68.1 | 68.1 | 68.1 | 68.1 | 68.1 |
| R_{UVLO2} (k Ω) | 21.5 | 18.7 | 16.9 | 15.4 | 14.0 | 13.0 | 12.1 | 11.3 | 10.5 | 9.76 | 9.31 |
| Hysteresis (mV) | 400 | 415 | 430 | 450 | 465 | 480 | 500 | 515 | 530 | 550 | 565 |

For a split rail application, if a secondary UVLO on PVIN is required, VIN must be $\geq 4.5V$. Figure 41 shows the PVIN UVLO configuration. Use Table 9 to select R_{UVLO1} and R_{UVLO2} for PVIN. If PVIN UVLO is set for less than 3.5 V, a 5.1-V zener diode should be added to clamp the voltage on the UVLO pin below 6 V.

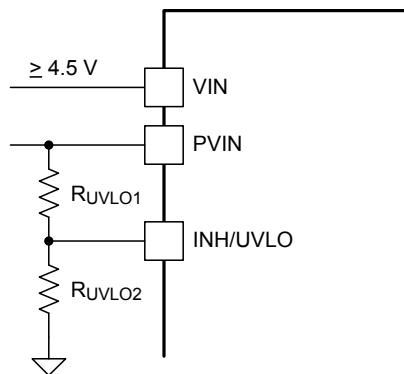

Figure 41. Adjustable PVIN Undervoltage Lockout, (VIN $\geq 4.5V$)

Table 9. Standard Resistor Values for Adjusting PVIN UVLO, (VIN $\geq 4.5V$)

| PVIN UVLO (V) | 2.9 | 3.0 | 3.5 | 4.0 | 4.5 | For higher PVIN UVLO voltages see Table 8 for resistor values |
|---------------------------|------|------|------|------|------|---|
| R_{UVLO1} (k Ω) | 68.1 | 68.1 | 68.1 | 68.1 | 68.1 | |
| R_{UVLO2} (k Ω) | 47.5 | 44.2 | 34.8 | 28.7 | 24.3 | |
| Hysteresis (mV) | 330 | 335 | 350 | 365 | 385 | |

9.23 Layout Considerations

To achieve optimal electrical and thermal performance, an optimized PCB layout is required. [Figure 42](#) thru [Figure 45](#), shows a typical PCB layout. Some considerations for an optimized layout are:

- Use large copper areas for power planes (PVIN, VOUT, and PGND) to minimize conduction loss and thermal stress.
- Place ceramic input and output capacitors close to the device pins to minimize high frequency noise.
- Locate additional output capacitors between the ceramic capacitor and the load.
- Keep AGND and PGND separate from one another.
- Place R_{SET} , R_{RT} , and C_{SS} as close as possible to their respective pins.
- Use multiple vias to connect the power planes to internal layers.

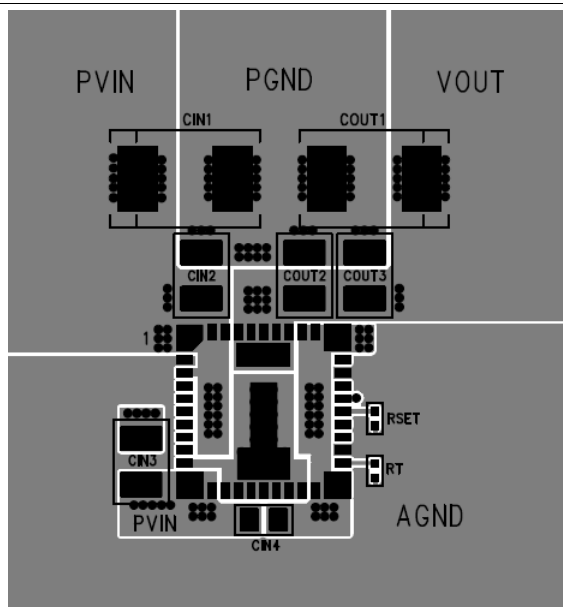

Figure 42. Typical Top-Layer Layout

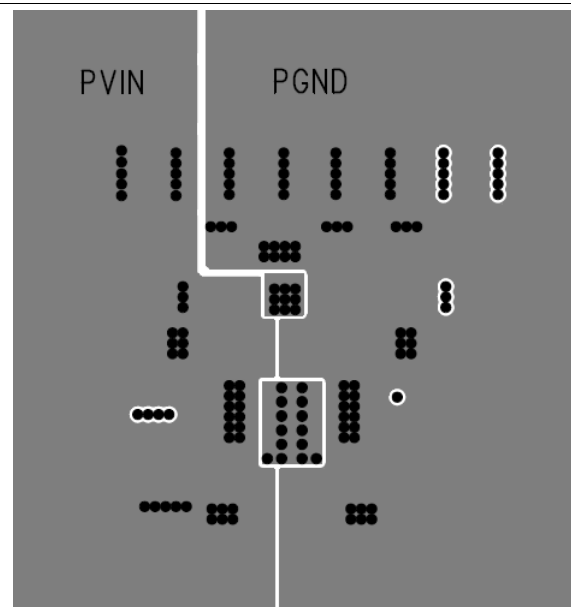

Figure 43. Typical Layer-2 Layout

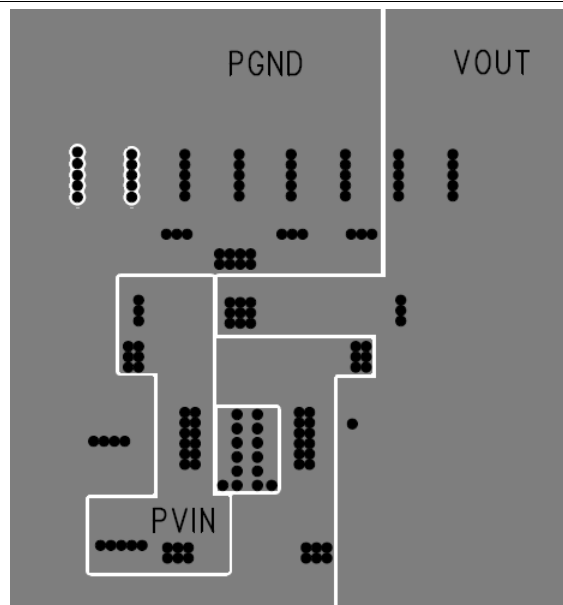

Figure 44. Typical Layer-3 Layout

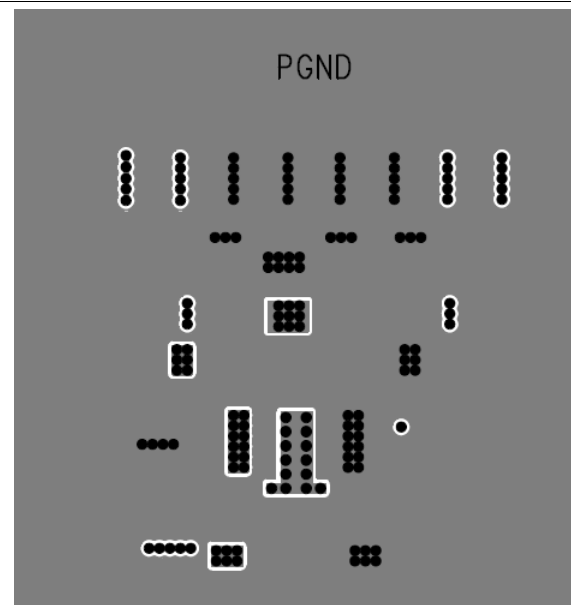
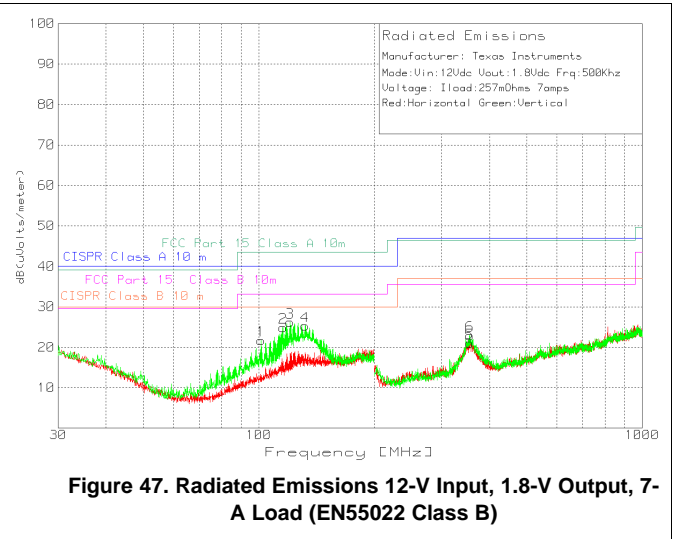
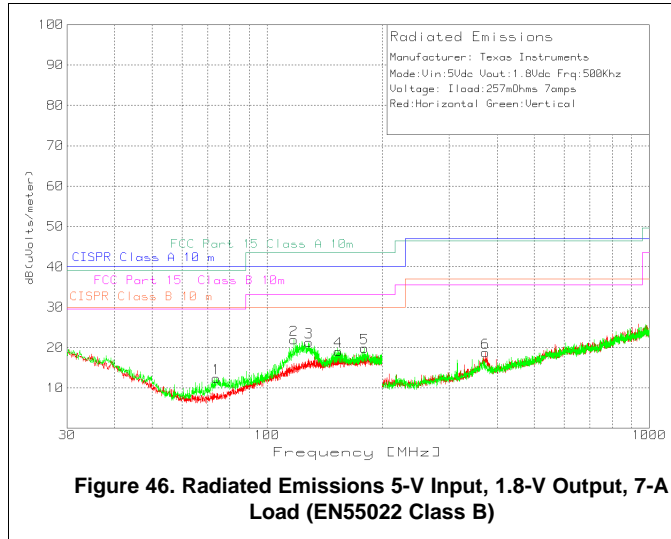

Figure 45. Typical Bottom-Layer Layout

9.24 EMI

The LMZ31707 is compliant with EN55022 Class B radiated emissions. [Figure 46](#) and [Figure 47](#) show typical examples of radiated emissions plots for the LMZ31707 operating from 5V and 12V respectively. Both graphs include the plots of the antenna in the horizontal and vertical positions.



10 Revision History

NOTE: Page numbers for previous revisions may differ from page numbers in the current version.

Changes from Revision C (April 2018) to Revision D Page

- Added ESD Ratings information [2](#)
-

Changes from Revision B (June 2017) to Revision C Page

- Added WEBENCH® design links for the LMZ31707 [1](#)
 - Increased the peak reflow temperature and maximum number of reflows to JEDEC specifications for improved manufacturability [2](#)
 - Added *Device Support* section [29](#)
 - Added *Mechanical, Packaging, and Orderable Information* section [30](#)
-

Changes from Revision A (August 2013) to Revision B Page

- Added peak reflow and maximum number of reflows information [2](#)
-

11 Device and Documentation Support

11.1 Device Support

11.1.1 Development Support

11.1.1.1 Custom Design With WEBENCH® Tools

Click [here](#) to create a custom design using the LMZ31707 device with the WEBENCH® Power Designer.

1. Start by entering the input voltage (V_{IN}), output voltage (V_{OUT}), and output current (I_{OUT}) requirements.
2. Optimize the design for key parameters such as efficiency, footprint, and cost using the optimizer dial.
3. Compare the generated design with other possible solutions from Texas Instruments.

The WEBENCH Power Designer provides a customized schematic along with a list of materials with real-time pricing and component availability.

In most cases, these actions are available:

- Run electrical simulations to see important waveforms and circuit performance
- Run thermal simulations to understand board thermal performance
- Export customized schematic and layout into popular CAD formats
- Print PDF reports for the design, and share the design with colleagues

Get more information about WEBENCH tools at www.ti.com/WEBENCH.

11.2 Documentation Support

11.2.1 Related Documentation

For related documentation see the following:

[Soldering Requirements for BQFN Packages](#)

11.3 Receiving Notification of Documentation Updates

To receive notification of documentation updates, navigate to the device product folder on ti.com. In the upper right corner, click on *Alert me* to register and receive a weekly digest of any product information that has changed. For change details, review the revision history included in any revised document.

11.4 Community Resources

The following links connect to TI community resources. Linked contents are provided "AS IS" by the respective contributors. They do not constitute TI specifications and do not necessarily reflect TI's views; see TI's [Terms of Use](#).

TI E2E™ Online Community *TI's Engineer-to-Engineer (E2E) Community*. Created to foster collaboration among engineers. At e2e.ti.com, you can ask questions, share knowledge, explore ideas and help solve problems with fellow engineers.

Design Support *TI's Design Support* Quickly find helpful E2E forums along with design support tools and contact information for technical support.

11.5 Trademarks

Eco-mode, E2E are trademarks of Texas Instruments.
WEBENCH is a registered trademark of Texas Instruments.
All other trademarks are the property of their respective owners.

11.6 Electrostatic Discharge Caution



This integrated circuit can be damaged by ESD. Texas Instruments recommends that all integrated circuits be handled with appropriate precautions. Failure to observe proper handling and installation procedures can cause damage.

ESD damage can range from subtle performance degradation to complete device failure. Precision integrated circuits may be more susceptible to damage because very small parametric changes could cause the device not to meet its published specifications.

11.7 Glossary

SLYZ022 — TI Glossary.

This glossary lists and explains terms, acronyms, and definitions.

12 Mechanical, Packaging, and Orderable Information

The following pages include mechanical, packaging, and orderable information. This information is the most current data available for the designated devices. This data is subject to change without notice and revision of this document. For browser-based versions of this data sheet, refer to the left-hand navigation.

12.1 Tape and Reel Information

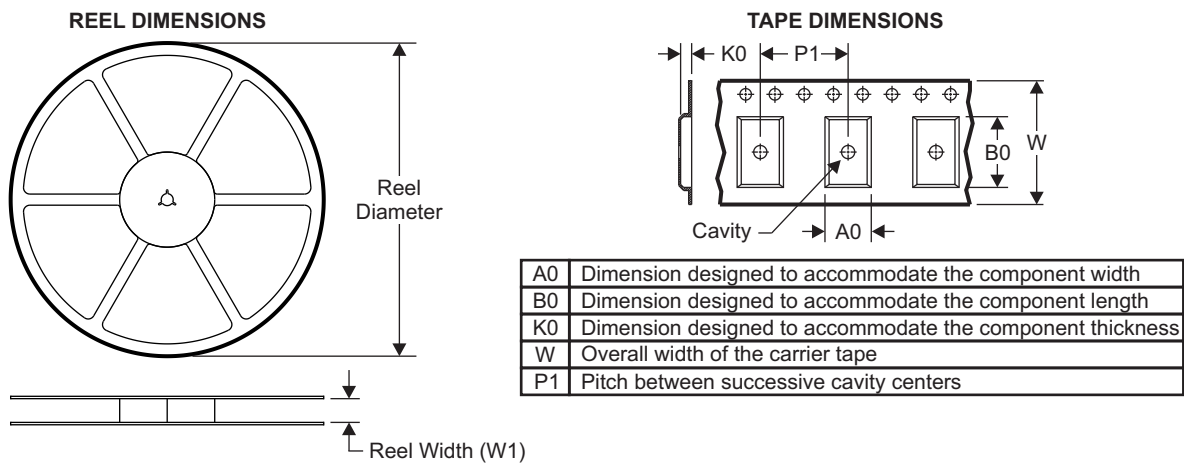

QUADRANT ASSIGNMENTS FOR PIN 1 ORIENTATION IN TAPE

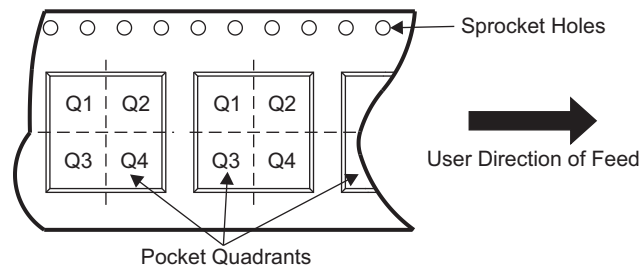

| Device | Package Type | Package Drawing | Pins | SPQ | Reel Diameter (mm) | Reel Width W1 (mm) | A0 (mm) | B0 (mm) | K0 (mm) | P1 (mm) | W (mm) | Pin1 Quadrant |
|--------------|--------------|-----------------|------|-----|--------------------|--------------------|---------|---------|---------|---------|--------|---------------|
| LMZ31707RVQR | B3QFN | RVQ | 42 | 500 | 330.0 | 24.4 | 10.35 | 10.35 | 4.6 | 16.0 | 24.0 | Q2 |
| LMZ31707RVQT | B3QFN | RVQ | 42 | 250 | 330.0 | 24.4 | 10.35 | 10.35 | 4.6 | 16.0 | 24.0 | Q2 |

TAPE AND REEL BOX DIMENSIONS

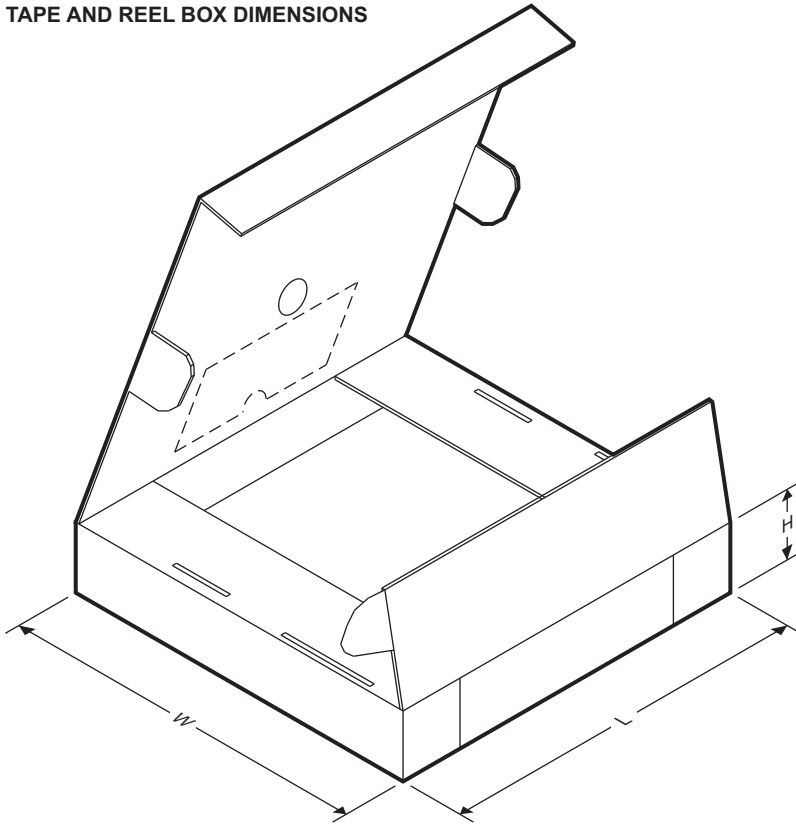

| Device | Package Type | Package Drawing | Pins | SPQ | Length (mm) | Width (mm) | Height (mm) |
|--------------|--------------|-----------------|------|-----|-------------|------------|-------------|
| LMZ31707RVQR | B3QFN | RVQ | 42 | 500 | 383.0 | 353.0 | 58.0 |
| LMZ31707RVQT | B3QFN | RVQ | 42 | 250 | 383.0 | 353.0 | 58.0 |

PACKAGING INFORMATION

| Orderable Device | Status (1) | Package Type | Package Drawing | Pins | Package Qty | Eco Plan (2) | Lead/Ball Finish (6) | MSL Peak Temp (3) | Op Temp (°C) | Device Marking (4/5) | Samples |
|------------------|---------------|--------------|-----------------|------|-------------|---------------------|-------------------------|----------------------|--------------|-------------------------|-------------------------|
| LMZ31707RVQR | ACTIVE | B3QFN | RVQ | 42 | 500 | RoHS Exempt & Green | CU NIPDAU | Level-3-245C-168 HR | -40 to 85 | (54020, LMZ31707) | Samples |
| LMZ31707RVQT | ACTIVE | B3QFN | RVQ | 42 | 250 | RoHS Exempt & Green | CU NIPDAU | Level-3-245C-168 HR | -40 to 85 | (54020, LMZ31707) | Samples |

(1) The marketing status values are defined as follows:

ACTIVE: Product device recommended for new designs.

LIFEBUY: TI has announced that the device will be discontinued, and a lifetime-buy period is in effect.

NRND: Not recommended for new designs. Device is in production to support existing customers, but TI does not recommend using this part in a new design.

PREVIEW: Device has been announced but is not in production. Samples may or may not be available.

OBSOLETE: TI has discontinued the production of the device.

(2) **RoHS:** TI defines "RoHS" to mean semiconductor products that are compliant with the current EU RoHS requirements for all 10 RoHS substances, including the requirement that RoHS substance do not exceed 0.1% by weight in homogeneous materials. Where designed to be soldered at high temperatures, "RoHS" products are suitable for use in specified lead-free processes. TI may reference these types of products as "Pb-Free".

RoHS Exempt: TI defines "RoHS Exempt" to mean products that contain lead but are compliant with EU RoHS pursuant to a specific EU RoHS exemption.

Green: TI defines "Green" to mean the content of Chlorine (Cl) and Bromine (Br) based flame retardants meet JS709B low halogen requirements of <=1000ppm threshold. Antimony trioxide based flame retardants must also meet the <=1000ppm threshold requirement.

(3) MSL, Peak Temp. - The Moisture Sensitivity Level rating according to the JEDEC industry standard classifications, and peak solder temperature.

(4) There may be additional marking, which relates to the logo, the lot trace code information, or the environmental category on the device.

(5) Multiple Device Markings will be inside parentheses. Only one Device Marking contained in parentheses and separated by a "~" will appear on a device. If a line is indented then it is a continuation of the previous line and the two combined represent the entire Device Marking for that device.

(6) Lead/Ball Finish - Orderable Devices may have multiple material finish options. Finish options are separated by a vertical ruled line. Lead/Ball Finish values may wrap to two lines if the finish value exceeds the maximum column width.

Important Information and Disclaimer:The information provided on this page represents TI's knowledge and belief as of the date that it is provided. TI bases its knowledge and belief on information provided by third parties, and makes no representation or warranty as to the accuracy of such information. Efforts are underway to better integrate information from third parties. TI has taken and continues to take reasonable steps to provide representative and accurate information but may not have conducted destructive testing or chemical analysis on incoming materials and chemicals. TI and TI suppliers consider certain information to be proprietary, and thus CAS numbers and other limited information may not be available for release.

In no event shall TI's liability arising out of such information exceed the total purchase price of the TI part(s) at issue in this document sold by TI to Customer on an annual basis.

RVQ (S-PB3QFN-N42)

PLASTIC QUAD FLATPACK NO-LEAD

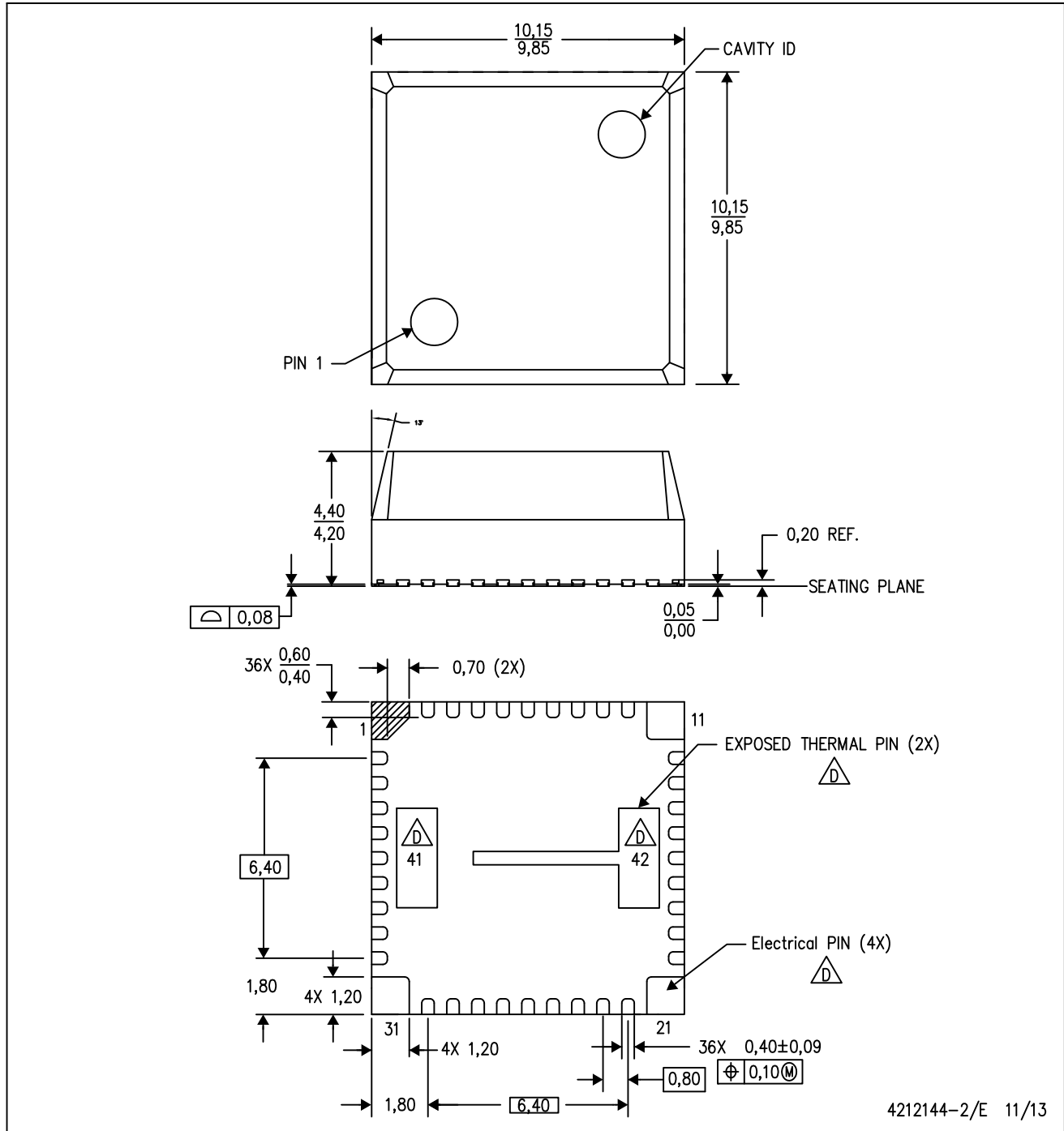

4212144-2/E 11/13

- NOTES:
- A. All linear dimensions are in millimeters. Dimensioning and tolerancing per ASME Y14.5M-1994.
 - B. This drawing is subject to change without notice.
 - C. Quad Flatpack, No-leads (QFN) package configuration.
 - The package thermal pad must be soldered to the board for thermal and mechanical performance.
 - E. See the additional figure in the Product Data Sheet for details regarding the exposed thermal pad features and dimensions.
 - The package thermal performance may be enhanced by bonding the thermal pad to an external thermal plane.

THERMAL PAD MECHANICAL DATA

RVQ (R-PB3QFN-N42)

PLASTIC QUAD FLATPACK NO-LEAD

THERMAL INFORMATION

This package incorporates an exposed thermal pad that is designed to be attached directly to an external heatsink. The thermal pad must be soldered directly to the printed circuit board (PCB). After soldering, the PCB can be used as a heatsink. In addition, through the use of thermal vias, the thermal pad can be attached directly to the appropriate copper plane shown in the electrical schematic for the device, or alternatively, can be attached to a special heatsink structure designed into the PCB. This design optimizes the heat transfer from the integrated circuit (IC).

For information on the Quad Flatpack No-Lead (QFN) package and its advantages, refer to Application Report, QFN/SON PCB Attachment, Texas Instruments Literature No. SLUA271. This document is available at www.ti.com.

The exposed thermal pad dimensions for this package are shown in the following illustration.

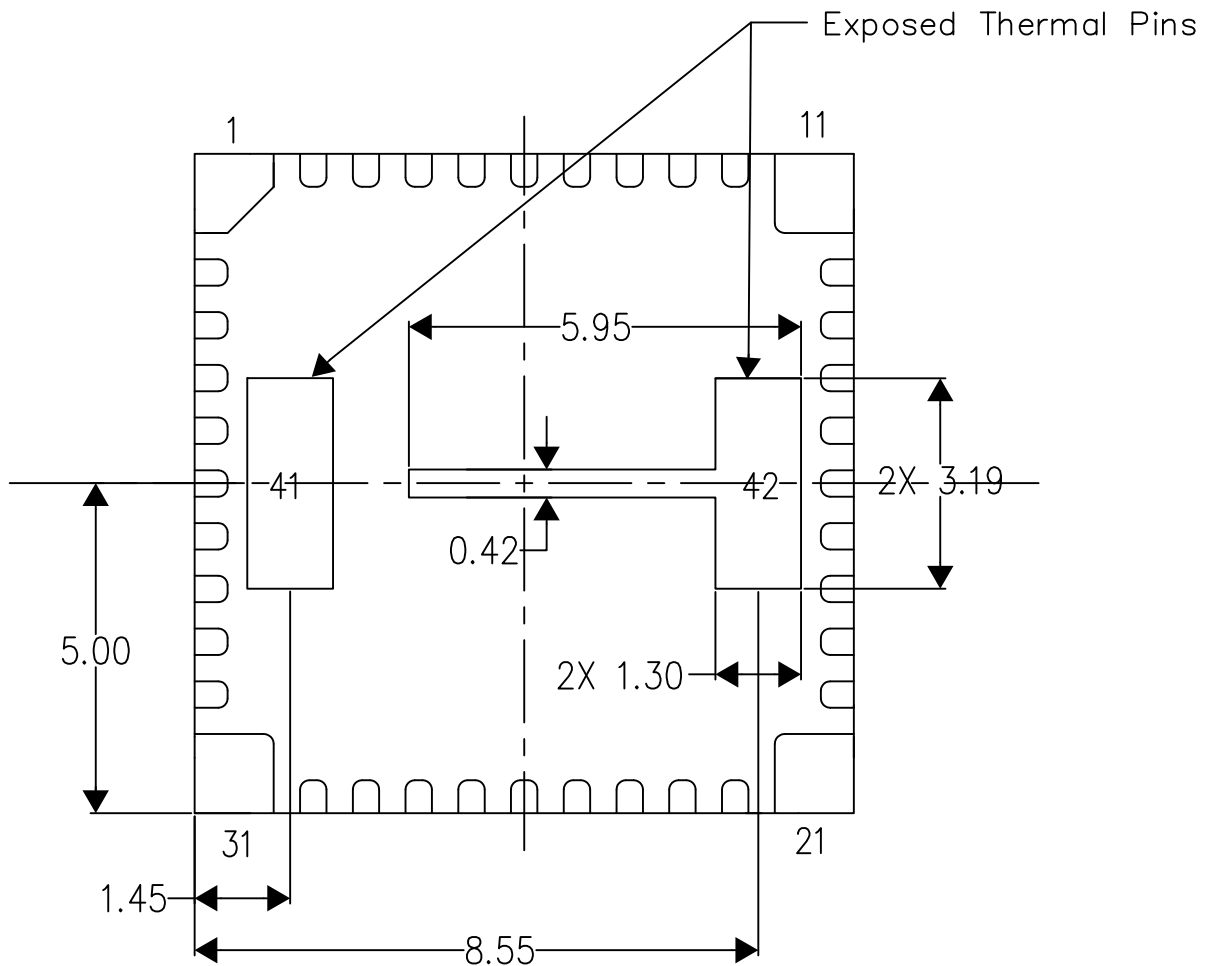

Bottom View

Exposed Thermal Pad Dimensions
Thermal Pad Tolerance: $\pm 0.10\text{mm}$

4221144-2/C 02/14

NOTE: All linear dimensions are in millimeters

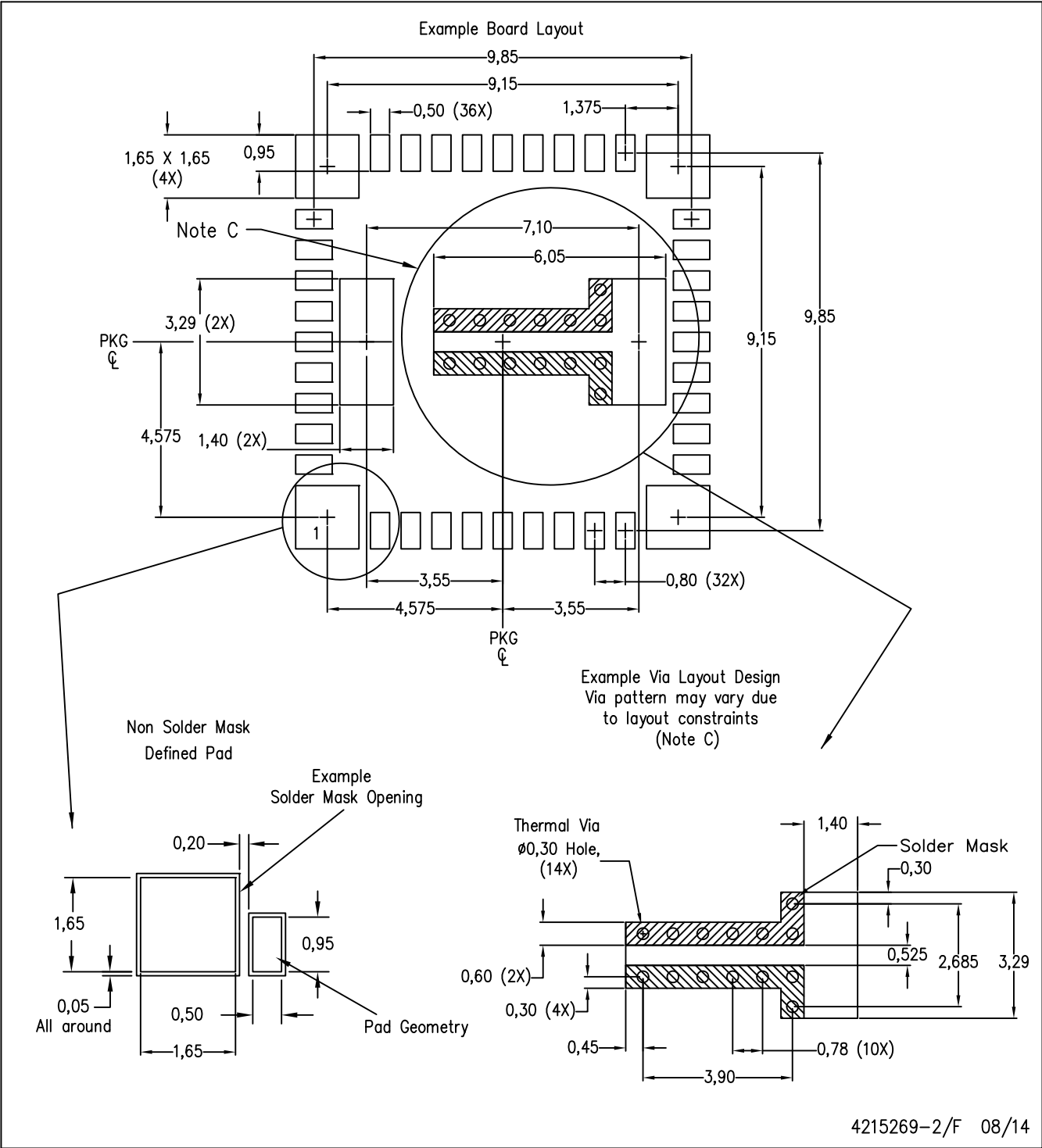

4215269-2/F 08/14

- NOTES:
- A. All linear dimensions are in millimeters.
 - B. This drawing is subject to change without notice.
 - C. This package is designed to be soldered to a thermal pad on the board. Refer to Application Note, Quad Flat-Pack Packages, Texas Instruments Literature No. SCBA017, SLUA271, and also the Product Data Sheets for specific thermal information, via requirements, and recommended board layout. These documents are available at www.ti.com <<http://www.ti.com>>.
 - D. See next page for stencil design recommendation.

Example Stencil Design (Note E)
Stencil Thickness = 0,125mm

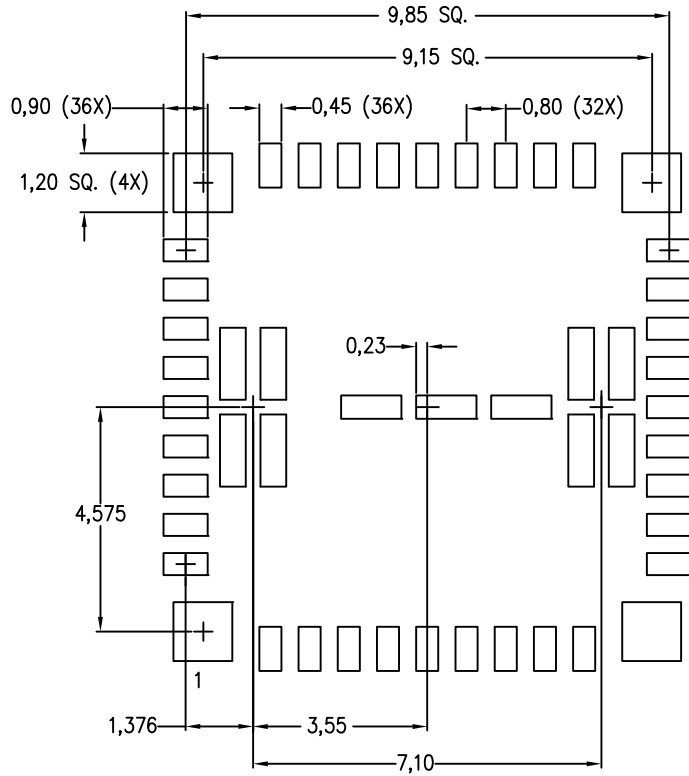

60% solder coverage on center pads

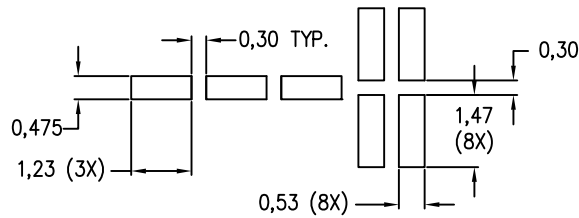

4215269-3/F 08/14

NOTES:

- E. Laser cutting apertures with trapezoidal walls and also rounding corners will offer better paste release. Customers should contact their board assembly site for stencil design recommendations. Refer to IPC 7525 for stencil design considerations.

IMPORTANT NOTICE AND DISCLAIMER

TI PROVIDES TECHNICAL AND RELIABILITY DATA (INCLUDING DATASHEETS), DESIGN RESOURCES (INCLUDING REFERENCE DESIGNS), APPLICATION OR OTHER DESIGN ADVICE, WEB TOOLS, SAFETY INFORMATION, AND OTHER RESOURCES "AS IS" AND WITH ALL FAULTS, AND DISCLAIMS ALL WARRANTIES, EXPRESS AND IMPLIED, INCLUDING WITHOUT LIMITATION ANY IMPLIED WARRANTIES OF MERCHANTABILITY, FITNESS FOR A PARTICULAR PURPOSE OR NON-INFRINGEMENT OF THIRD PARTY INTELLECTUAL PROPERTY RIGHTS.

These resources are intended for skilled developers designing with TI products. You are solely responsible for (1) selecting the appropriate TI products for your application, (2) designing, validating and testing your application, and (3) ensuring your application meets applicable standards, and any other safety, security, or other requirements. These resources are subject to change without notice. TI grants you permission to use these resources only for development of an application that uses the TI products described in the resource. Other reproduction and display of these resources is prohibited. No license is granted to any other TI intellectual property right or to any third party intellectual property right. TI disclaims responsibility for, and you will fully indemnify TI and its representatives against, any claims, damages, costs, losses, and liabilities arising out of your use of these resources.

TI's products are provided subject to TI's Terms of Sale (www.ti.com/legal/termsofsale.html) or other applicable terms available either on ti.com or provided in conjunction with such TI products. TI's provision of these resources does not expand or otherwise alter TI's applicable warranties or warranty disclaimers for TI products.

Mailing Address: Texas Instruments, Post Office Box 655303, Dallas, Texas 75265
Copyright © 2019, Texas Instruments Incorporated

Looking for pricing, stock, or lifecycle information?

Click below to explore more details on WIN SOURCE:

 [View LMZ31707RVQT](#) on WIN SOURCE

 [Texas Instruments](#) Information

Optimize Your Supply Chain with WIN SOURCE Solutions

-  Global Sourcing Solution
-  Obsolete Management
-  Cost Control Management
-  Shortage Management
-  Alternative Solution
-  Excess Inventory Management