



**THE DATASHEET OF  
MCP1791T-3002E/DC**



## DESCRIPTION

The MP8768 is a high frequency synchronous rectified step-down switch mode converter with a built in internal high side power MOSFET. It offers a very compact solution to achieve 8A continuous output current over a wide input supply range with excellent load and line regulation. The MP8768 has very high efficiency over a wide output load range.

Current mode operation provides fast transient response and eases loop stabilization.

Full protection features include OCP and thermal shut down.

The MP8768 requires a minimum number of readily available standard external components and is available in a space saving 3mm x 4mm 14-pin QFN package.

## FEATURES

- Wide 4.5V to 28V Operating Input Range
- 8A Output Current
- 50mΩ Internal High side Power MOSFET
- Fixed 600KHz switching frequency
- Sync from 300KHz to 2MHz External Clock
- Internal Compensation
- Power Good Output
- Integrated Bootstrap Diode
- OCP Protection and Thermal Shutdown
- Output Adjustable from 0.8V
- Available in 3mm x 4mm 14-pin QFN package.

## APPLICATIONS

- Notebook Systems and I/O Power
- Networking Systems
- Digital Set Top Boxes
- Personal Video Recorders
- Flat Panel Television and Monitors
- Distributed Power Systems

"MPS" and "The Future of Analog IC Technology" are Registered Trademarks of Monolithic Power Systems, Inc.

## TYPICAL APPLICATION

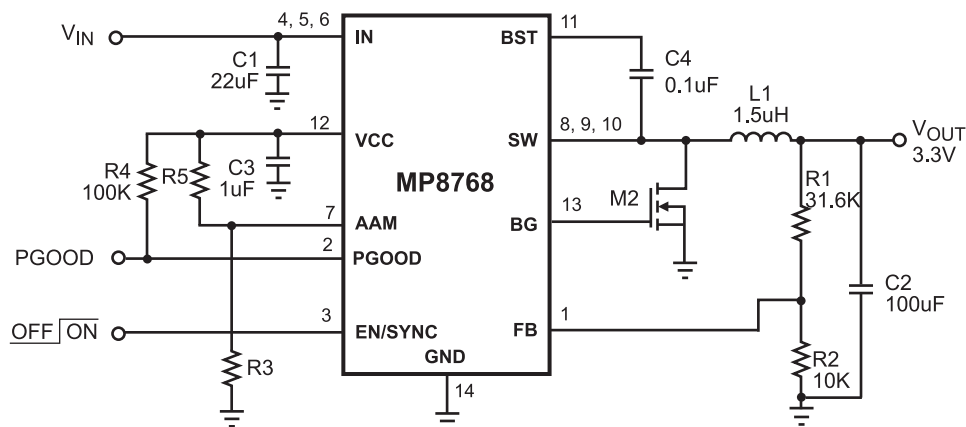

## PACKAGE REFERENCE

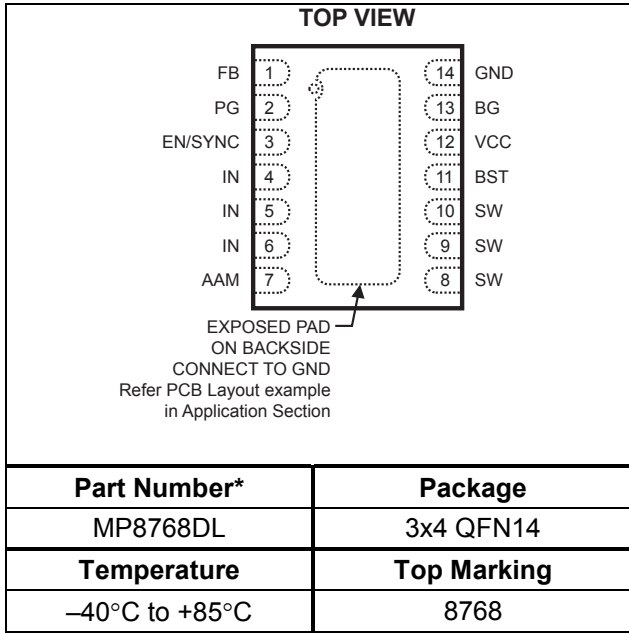

\* For Tape & Reel, add suffix -Z (eg. MP8768DL-Z)  
 For RoHS compliant packaging, add suffix -LF  
 (eg. MP8768DL-LF-Z)

## ABSOLUTE MAXIMUM RATINGS <sup>(1)</sup>

Supply Voltage  $V_{IN}$  ..... 30V  
 $V_{SW}$  ..... -0.3V (-5V for < 10ns) to 31V  
 $V_{BS}$  .....  $V_{SW} + 6V$   
 All Other Pins ..... -0.3V to +6V  
 Junction Temperature ..... 150°C  
 Lead Temperature ..... 260°C  
 Storage Temperature ..... -65°C to +150°C

## Recommended Operating Conditions <sup>(2)</sup>

Supply Voltage  $V_{IN}$  ..... 4.5V to 28V  
 Operating Temperature ..... -40°C to +85°C

## Thermal Resistance <sup>(3)</sup> $\theta_{JA}$ $\theta_{JC}$

3x4 QFN14 ..... 48 ..... 11 ... °C/W

### Notes:

- 1) Exceeding these ratings may damage the device.
- 2) The device is not guaranteed to function outside of its operating conditions.
- 3) Measured on JESD51-7, 4-layer PCB.

## ELECTRICAL CHARACTERISTICS

$V_{IN} = 12V$ ,  $T_A = +25^\circ C$ , unless otherwise noted.

Parameters	Symbol	Condition	Min	Typ	Max	Units
Supply Current (Shutdown)	$I_{IN}$	$V_{EN} = 0V$		0	1.0	$\mu A$
Supply Current (Quiescent)	$I_{IN}$	$V_{EN} = 2V$ , $V_{FB} = 1V$		1	1.2	mA
Switch On Resistance <sup>(4)</sup>	$SW_{RDS-ON}$			50		m $\Omega$
Switch Leakage	$SW_{LKG}$	$V_{EN} = 0V$ , $V_{SW} = 0V$		0	10	$\mu A$
Current Limit <sup>(4)</sup>	$I_{LIMIT}$		9.5			A
Oscillator Frequency	$F_{SW}$	$V_{FB} = 700mV$	400	600	800	KHz
Fold-back Frequency	$F_{FB}$	$V_{FB} = 0V$		0.25		$f_{SW}$
Maximum Duty Cycle	$D_{MAX}$	$V_{FB} = 700mV$	85	90		%
Sync Frequency Range	$F_{SYNC}$	$4.5V \leq V_{IN} \leq 28V$	0.3		2	MHz
Feedback Voltage	$V_{FB}$		788	808	828	mV
Feedback Current	$I_{FB}$	$V_{FB} = 800mV$		10	50	nA
EN/SYNC Input Low Voltage	$EN_{VIL}$				0.4	V
EN/SYNC Input High Voltage	$EN_{VIH}$		2			V
EN Input Current	$I_{EN}$	$V_{EN} = 2V$		2		$\mu A$
		$V_{EN} = 0V$		0		
EN Turn Off Delay	$EN_{Td-Off}$			5		$\mu s$
Power Good Threshold Rising	$PG_{Vth\_Hi}$			0.9		$V_{FB}$
Power Good Threshold Falling	$PG_{Vth\_Lo}$			0.7		$V_{FB}$

**ELECTRICAL CHARACTERISTICS** (continued)

V<sub>IN</sub> = 12V, T<sub>A</sub> = +25°C, unless otherwise noted.

Parameters	Symbol	Condition	Min	Typ	Max	Units
Power Good Delay	PG <sub>Td</sub>			20		µs
Power Good Sink Current Capability	PG <sub>VOL</sub>	Sink 4mA			0.4	V
Power Good Leakage Current	PG <sub>LKG</sub>	V <sub>PG</sub> = 3.3V			10	nA
Under Voltage Lockout Threshold Rising			3.9	4.1	4.3	V
Under Voltage Lockout Threshold Hysteresis				880		mV
VCC Regulator	V <sub>CC</sub>		4.5	5		V
VCC Load Regulation		I <sub>CC</sub> =20mA		5		%
Gate Drive Sink Impedance <sup>(4)</sup>	R <sub>SINK</sub>			1		Ω
Gate Drive Source Impedance <sup>(4)</sup>	R <sub>SOURCE</sub>			4		Ω
Thermal Shutdown	T <sub>SD</sub>			150		°C

Note:

4) Guaranteed by design.

**PIN FUNCTIONS**

Pin #	Name	Description
1	FB	Feedback. An external resistor divider from the output to GND, tapped to the FB pin, sets the output voltage. To prevent current limit run away during a short circuit fault condition the frequency fold-back comparator lowers the oscillator frequency when the FB voltage is below 400mV.
2	PG	Power good output, the output of this pin is an open drain and is low if the output voltage is lower than 10% of the nominal voltage. There is a 20µs delay to pull PG if the output voltage is lower than 10% of regulation value.
3	EN/SYNC	EN=1 to enable the MP8768. External clock can be applied to EN pin for changing switching frequency. For automatic start-up, connect EN pin to VIN with 100KΩ resistor.
4,5,6	IN	Supply Voltage. The MP8768 operates from a +4.5V to +28V input rail. C1 is needed to decouple the input rail. Use wide PCB traces and multiple vias to make the connection.
7	AAM	Tie to ground forces the MP8768 in synchronous Mode. Tie to a voltage set by a resistor divider forces the MP8768 into non-synchronous mode when load is small.
8,9,10	SW	Switch Output. Use wide PCB traces and multiple vias to make the connection.
11	BST	Bootstrap. A capacitor connected between SW and BS pins is required to form a floating supply across the high-side switch driver.
12	VCC	Bias Supply. Decouple with 1µF capacitor.
13	BG	Low Side Gate Drive output.
14	GND Exposed Pad	System Ground. This pin is the reference ground of the regulated output voltage. For this reason care must be taken in PCB layout. Connect exposed pad to GND plane for optimal thermal performance.

## TYPICAL PERFORMANCE CHARACTERISTICS

$V_{IN} = 12V$ ,  $V_{OUT} = 3.3V$ ,  $L = 1.5\mu H$ ,  $T_A = +25^\circ C$ , unless otherwise noted.

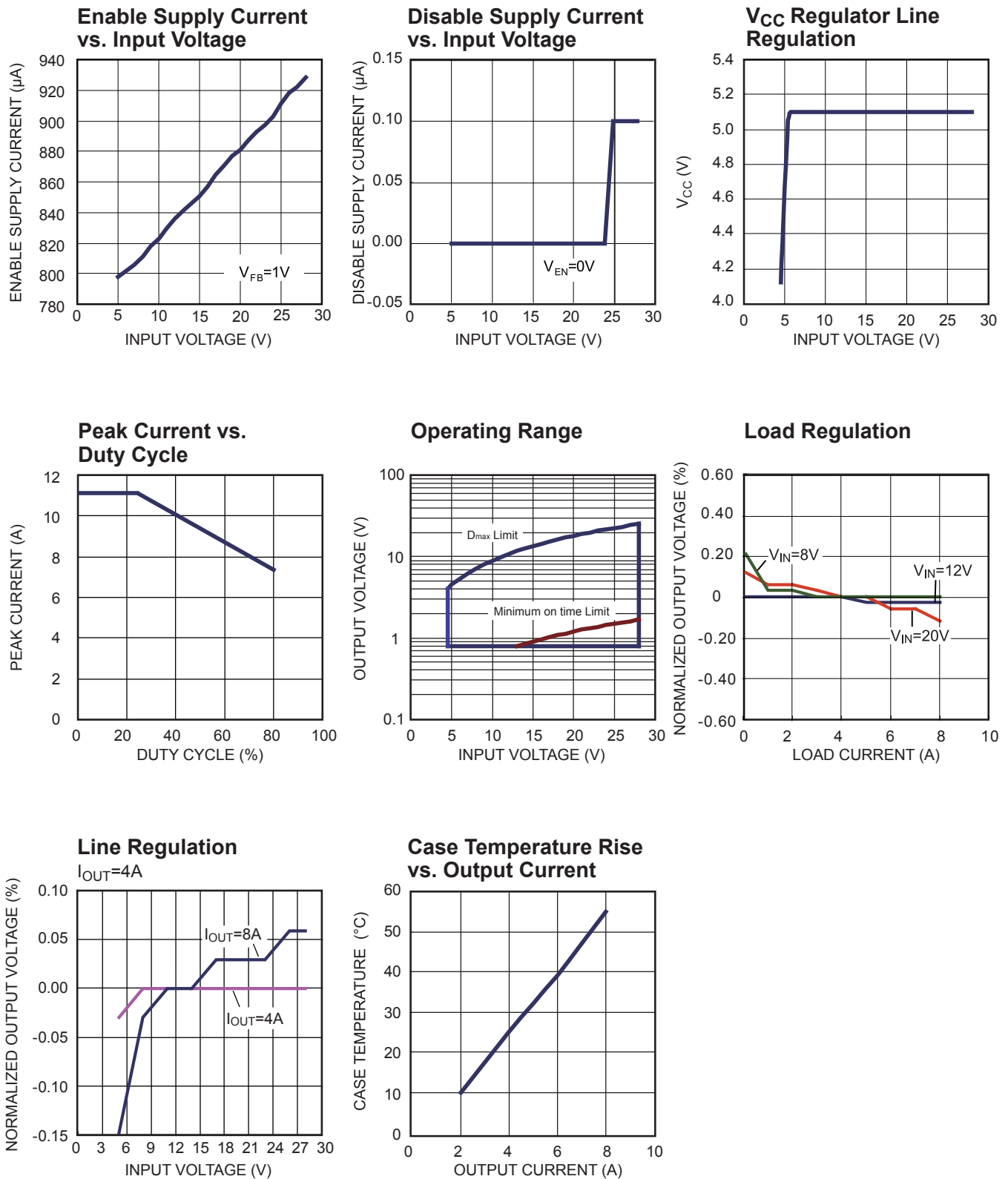

**TYPICAL PERFORMANCE CHARACTERISTICS** (continued)

$V_{IN} = 12V$ ,  $V_{OUT} = 3.3V$ ,  $L = 1.5\mu H$ ,  $T_A = +25^\circ C$ , unless otherwise noted.

**Short Entry**

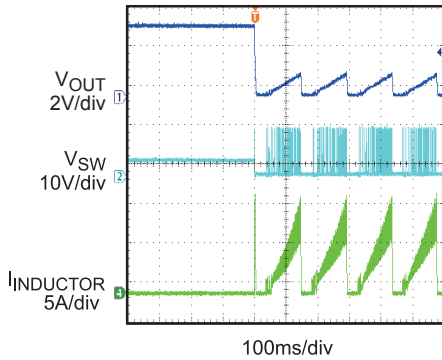

**Short Recovery**

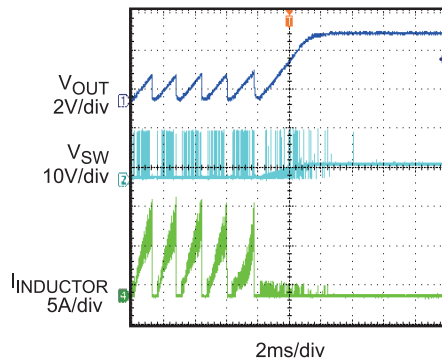

**Enable Startup without Load**

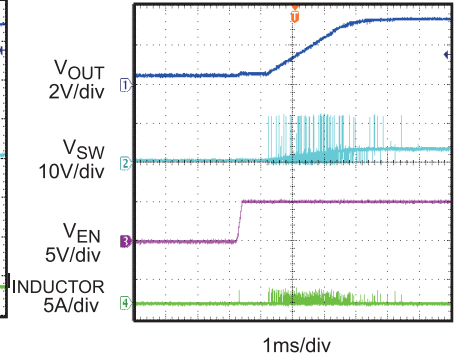

**Enable Startup with 8A Load (Resistive)**

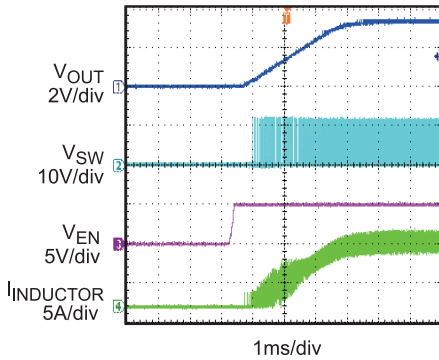

**Load Transient Response**

$I_{OUT} = 4A$  to  $8A$

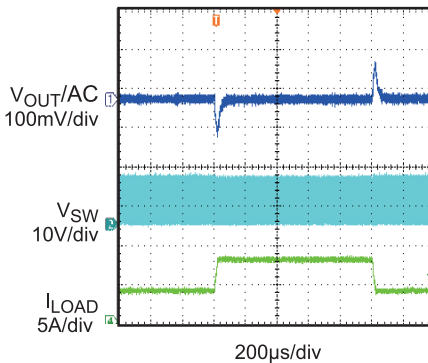

**Input Ripple Voltage**

$I_{OUT} = 8A$

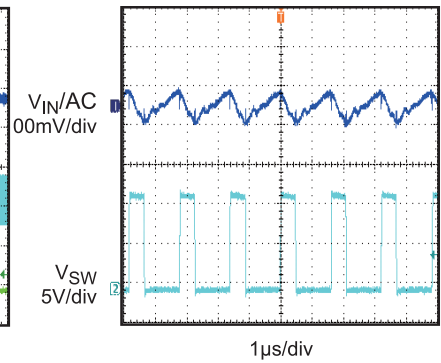

**Output Ripple Voltage**

$I_{OUT} = 0.6A$  (DCM Mode)

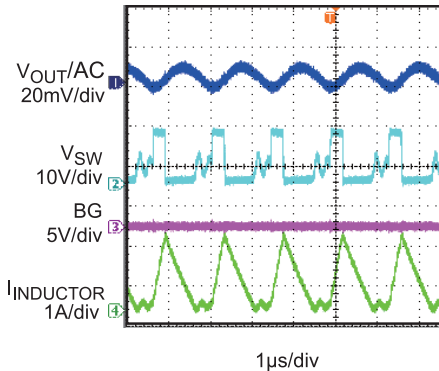

**Output Ripple Voltage**

$I_{OUT} = 8A$  (CCM Mode)

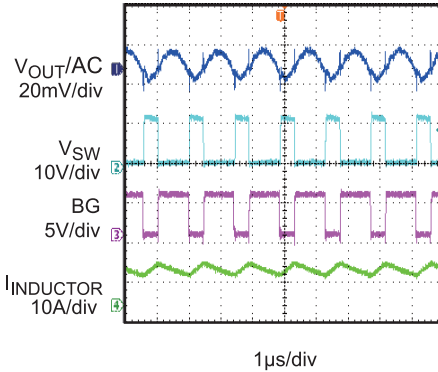

**BLOCK DIAGRAM**

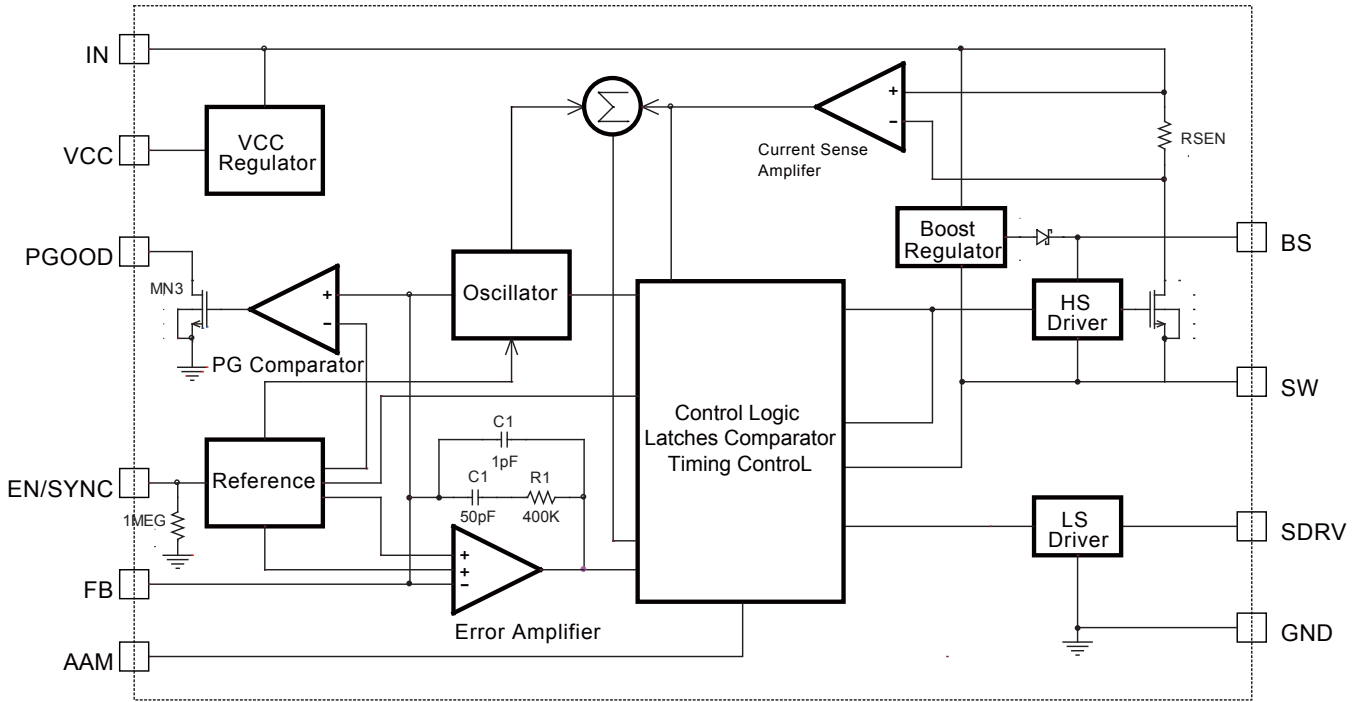

**Figure 1—Functional Block Diagram**

## OPERATION

The MP8768 is a high frequency synchronous rectified step-down switch mode converter with a built in internal high side power MOSFET. It offers a very compact solution to achieve 8A continuous output current over a wide input supply range with excellent load and line regulation.

The MP8768 operates in a fixed frequency, peak current control mode to regulate the output voltage. A PWM cycle is initiated by the internal clock. The integrated high-side power MOSFET is turned on and remains on until its current reaches the value set by the COMP voltage. When the power switch is off, it remains off until the next clock cycle starts. If, in 90% of one PWM period, the current in the power MOSFET does not reach the COMP set current value, the power MOSFET will be forced to turn off.

### Error Amplifier

The error amplifier compares the FB pin voltage with the internal 0.8V reference (REF) and outputs a current proportional to the difference between the two. This output current is then used to charge or discharge the internal compensation network to form the COMP voltage, which is used to control the power MOSFET current. The optimized internal compensation network minimizes the external component counts and simplifies the control loop design.

### Internal Regulator

Most of the internal circuitries are powered from the 5V internal regulator. This regulator takes the VIN input and operates in the full VIN range. When VIN is greater than 5.0V, the output of the regulator is in full regulation. When VIN is lower than 5.0V, the output decreases. Since this internal regulator provides the bias current for the bottom gate driver that requires significant amount of current depending upon the external MOSFET selection, a 1uF ceramic capacitor for decoupling purpose is required.

### Enable/Sync Control

The MP8768 has a dedicated Enable/Sync control pin (EN/SYNC). By pulling it high or low, the IC can be enabled and disabled by EN. Tie EN to VIN for automatic start up. To disable the part, EN must be pulled low for at least 5μs.

The MP8768 can be synchronized to external clock range from 300KHz up to 2MHz through the EN/SYNC pin. The internal clock rising edge is synchronized to the external clock rising edge.

### Under-Voltage Lockout (UVLO)

Under-voltage lockout (UVLO) is implemented to protect the chip from operating at insufficient supply voltage. The MP8768 UVLO comparator monitors the output voltage of the internal regulator, VCC. The UVLO rising threshold is about 4.0V while its falling threshold is a consistent 3.2V.

### Internal Soft-Start

The soft-start is implemented to prevent the converter output voltage from overshooting during startup. When the chip starts, the internal circuitry generates a soft-start voltage (SS) ramping up from 0V to 1.2V. When it is lower than the internal reference (REF), SS overrides REF so the error amplifier uses SS as the reference. When SS is higher than REF, REF regains control.

### Over-Current-Protection and Hiccup

The MP8768 has cycle-by-cycle over current limit when the inductor current peak value exceeds the set current limit threshold. Meanwhile, output voltage starts to drop until FB is below the Under-Voltage (UV) threshold, typically 30% below the reference. Once a UV is triggered, the MP8768 enters hiccup mode to periodically restart the part. This protection mode is especially useful when the output is dead-short to ground. The average short circuit current is greatly reduced to alleviate the thermal issue and to protect the regulator. The MP8768 exits the hiccup mode once the over current condition is removed.

### Thermal Shutdown

Thermal shutdown is implemented to prevent the chip from operating at exceedingly high temperatures. When the silicon die temperature is higher than 150°C, it shuts down the whole chip. When the temperature is lower than its lower threshold, typically 140°C, the chip is enabled again.

**Floating Driver and Bootstrap Charging**

The floating power MOSFET driver is powered by an external bootstrap capacitor. This floating driver has its own UVLO protection. This UVLO’s rising threshold is 2.2V with a hysteresis of 150mV. The bootstrap capacitor voltage is regulated internally (Figure 2). In DCM mode at light load condition, as long as  $V_{IN}$  is 3V higher than  $V_{OUT}$ , BST capacitor C4 will have enough voltage which is provided by  $V_{IN}$  through D1, M3, C4, L1 and C2. If  $(V_{IN}-V_{SW})$  is more than 5V, U2 will regulate M3 to maintain a 5V BST voltage across C4.

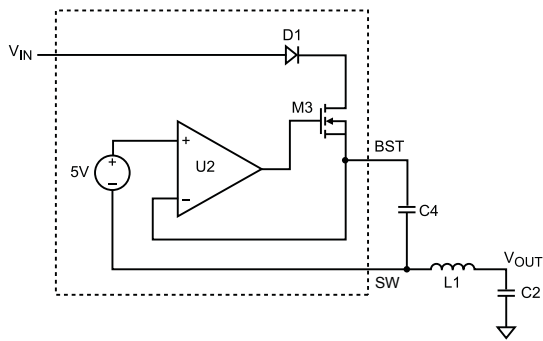

**Figure 2—Internal Bootstrap Charging Circuit**

**Startup and Shutdown**

If both  $V_{IN}$  and  $EN$  are higher than their appropriate thresholds, the chip starts. The reference block starts first, generating stable reference voltage and currents, and then the internal regulator is enabled. The regulator provides stable supply for the remaining circuitries.

Three events can shut down the chip:  $EN$  low,  $V_{IN}$  low and thermal shutdown. In the shutdown procedure, the signaling path is first blocked to avoid any fault triggering. The COMP voltage and the internal supply rail are then pulled down. The floating driver is not subject to this shutdown command.

## APPLICATION INFORMATION

### Setting the Output Voltage

The external resistor divider R1 and R2 is used to set the output voltage (see the schematic on front page). The feedback resistor R1 also sets the feedback loop bandwidth with the internal compensation capacitor (see Typical Application on page 1). Choose R1 to be around 31.6kΩ for optimal transient response. R2 is then given by:

$$R2 = \frac{R1}{\frac{V_{OUT}}{0.808V} - 1}$$

The T-type network is highly recommended when Vo is low, as Figure 3 shows.

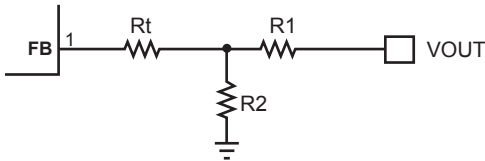

**Figure 3— T-type Network**

Table 1 lists the recommended T-type resistors value for common output voltages.

**Table 1—Resistor Selection for Common Output Voltages**

V <sub>OUT</sub> (V)	R1 (kΩ)	R2 (kΩ)	Rt (kΩ)
1.05	10 (1%)	33.2 (1%)	80.6 (1%)
1.2	10 (1%)	20.5 (1%)	80.6 (1%)
1.5	10 (1%)	11.8 (1%)	80.6 (1%)
1.8	10 (1%)	8.2 (1%)	80.6 (1%)
2.5	31.6 (1%)	14.7 (1%)	0
3.3	31.6 (1%)	10 (1%)	0
5	31.6 (1%)	6.04 (1%)	0

### Selecting the Inductor

A 1μH to 10μH inductor with a DC current rating of at least 25% percent higher than the maximum load current is recommended for most applications. For highest efficiency, the inductor DC resistance should be less than 15mΩ. For most designs, the inductance value can be derived from the following equation.

$$L = \frac{V_{OUT} \times (V_{IN} - V_{OUT})}{V_{IN} \times \Delta I_L \times f_{OSC}}$$

Where ΔI<sub>L</sub> is the inductor ripple current.

Choose inductor current to be approximately 30% if the maximum load current, 8A. The maximum inductor peak current is:

$$I_{L(MAX)} = I_{LOAD} + \frac{\Delta I_L}{2}$$

Under light load conditions below 100mA, larger inductance is recommended for improved efficiency.

### Synchronous MOSFET

The external synchronous MOSFET is used to supply current to the inductor when the internal high-side switch is off. It reduces the power loss significantly when compared against a Schottky rectifier.

Table 2 lists example synchronous MOSFETs and manufacturers.

**Table 2—Synchronous MOSFET Selection Guide**

Part No.	Manufacture
FDS6670AS	Fairchild
Si7112	Vishay
Si7114	Vishay
AM4874	Analog Power

### Selecting the Input Capacitor

The input current to the step-down converter is discontinuous, therefore a capacitor is required to supply the AC current to the step-down converter while maintaining the DC input voltage. Use low ESR capacitors for the best performance. Ceramic capacitors with X5R or X7R dielectrics are highly recommended because of their low ESR and small temperature coefficients. For most applications, a 22μF capacitor is sufficient.

Since the input capacitor (C1) absorbs the input switching current it requires an adequate ripple current rating. The RMS current in the input capacitor can be estimated by:

$$I_{C1} = I_{LOAD} \times \sqrt{\frac{V_{OUT}}{V_{IN}} \times \left(1 - \frac{V_{OUT}}{V_{IN}}\right)}$$

The worse case condition occurs at V<sub>IN</sub> = 2V<sub>OUT</sub>, where:

$$I_{C1} = \frac{I_{LOAD}}{2}$$

For simplification, choose the input capacitor whose RMS current rating greater than half of the maximum load current.

The input capacitor can be electrolytic, tantalum or ceramic. When using electrolytic or tantalum capacitors, a small, high quality ceramic capacitor, i.e. 0.1µF, should be placed as close to the IC as possible. When using ceramic capacitors, make sure that they have enough capacitance to provide sufficient charge to prevent excessive voltage ripple at input. The input voltage ripple caused by capacitance can be estimated by:

$$\Delta V_{IN} = \frac{I_{LOAD}}{f_s \times C1} \times \frac{V_{OUT}}{V_{IN}} \times \left(1 - \frac{V_{OUT}}{V_{IN}}\right)$$

**Selecting the Output Capacitor**

The output capacitor (C2) is required to maintain the DC output voltage. Ceramic, tantalum, or low ESR electrolytic capacitors are recommended. Low ESR capacitors are preferred to keep the output voltage ripple low. The output voltage ripple can be estimated by:

$$\Delta V_{OUT} = \frac{V_{OUT}}{f_s \times L} \times \left(1 - \frac{V_{OUT}}{V_{IN}}\right) \times \left(R_{ESR} + \frac{1}{8 \times f_s \times C2}\right)$$

Where L is the inductor value and R<sub>ESR</sub> is the equivalent series resistance (ESR) value of the output capacitor.

In the case of ceramic capacitors, the impedance at the switching frequency is dominated by the capacitance. The output voltage ripple is mainly caused by the capacitance. For simplification, the output voltage ripple can be estimated by:

$$\Delta V_{OUT} = \frac{V_{OUT}}{8 \times f_s^2 \times L \times C2} \times \left(1 - \frac{V_{OUT}}{V_{IN}}\right)$$

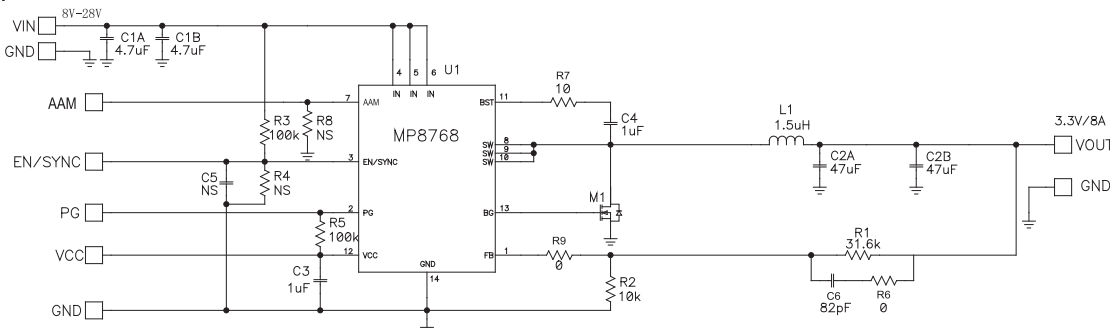

**Figure 5—Reference Design Circuit**

In the case of tantalum or electrolytic capacitors, the ESR dominates the impedance at the switching frequency. For simplification, the output ripple can be approximated to:

$$\Delta V_{OUT} = \frac{V_{OUT}}{f_s \times L} \times \left(1 - \frac{V_{OUT}}{V_{IN}}\right) \times R_{ESR}$$

The characteristics of the output capacitor also affect the stability of the regulation system. The MP8768 can be optimized for a wide range of capacitance and ESR values.

**External Bootstrap Diode**

An external bootstrap diode may enhance the efficiency of the regulator, the applicable conditions of external BST diode are:

- V<sub>OUT</sub> is 5V or 3.3V; and
- Duty cycle is high:  $D = \frac{V_{OUT}}{V_{IN}} > 65\%$

In these cases, an external BST diode is recommended from the output of the voltage regulator to BST pin, as shown in Figure 4

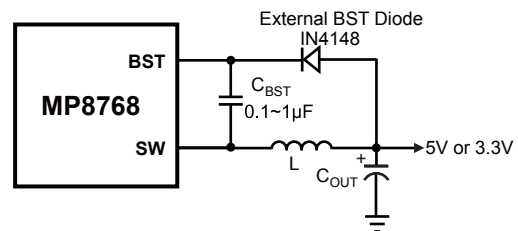

**Figure 4—Add Optional External Bootstrap Diode to Enhance Efficiency**

The recommended external BST diode is IN4148, and the BST cap is 0.1~1µF.

**Reference Design and PCB Layout**

Figure 5 and Table 3 shows the reference design.

**Table 3—BOM of Reference Design**

Qty	Ref	Value	Description	Package	Manufacturer	Part Number
2	C1A, C1B	4.7 $\mu$ F	Ceramic Cap, 50V, X7R	1210	Murata	GRM32ER71H475KA88L
2	C2A, C2B	47 $\mu$ F	Ceramic Cap, 10V, X5R	1210	Murata	GRM32ER61A476KE20L
2	C3, C4	1 $\mu$ F	Ceramic Cap, 16V, X7R	0603	Murata	GRM188R71C105KA12D
0	C5	NS				
1	C6	82pF	Ceramic Cap, 50V, COG	0603	Murata	GRM1885C1H820JA01D
1	R1	31.6k	Film Res., 1%	0603	Yageo	RC0603FR-0731K6L
1	R2	10k	Film Res., 1%	0603	Yageo	RC0603FR-0710KL
2	R3, R5	100k	Film Res., 5%	0603	Any	
0	R4, R6, R8	NS				
1	R7	10	Film Res., 5%	0603	Any	
1	L1	1.5 $\mu$ H	10m $\Omega$ DCR, 14A	SMD	Würth	744311150
1	M1		MOSFET, N-CH, 30V, 11.5m $\Omega$	SO8	Fairchild	FDS6670AS
1	U1		Step-Down Converter	QFN14	MPS	MP8768DL

Also PCB layout is very important to achieve stable operation. Please follow these guidelines and take Figure 5 and 6 for references.

- 1) Keep the path of switching current short and minimize the loop area formed by Input cap, high-side and low-side MOSFETs.
- 2) Keep the connection of low-side MOSFET between SW pin and input power ground as short and wide as possible.
- 3) Place the feedback resistors and compensation components as close to the chip as possible.
- 4) Route SW away from sensitive analog areas such as FB.
- 5) Connect IN, SW, and especially GND respectively to a large copper area to improve chip thermal performance and long-term reliability.
- 6) It is suggested to add snubber circuit across the high side MOSFET ( $V_{IN}$  pin and SW pin) so as to reduce SW spikes.

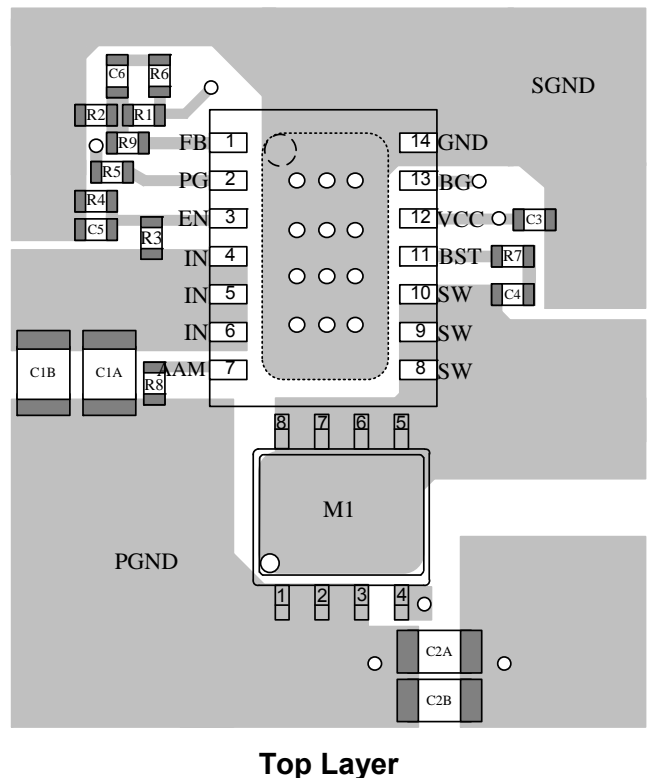

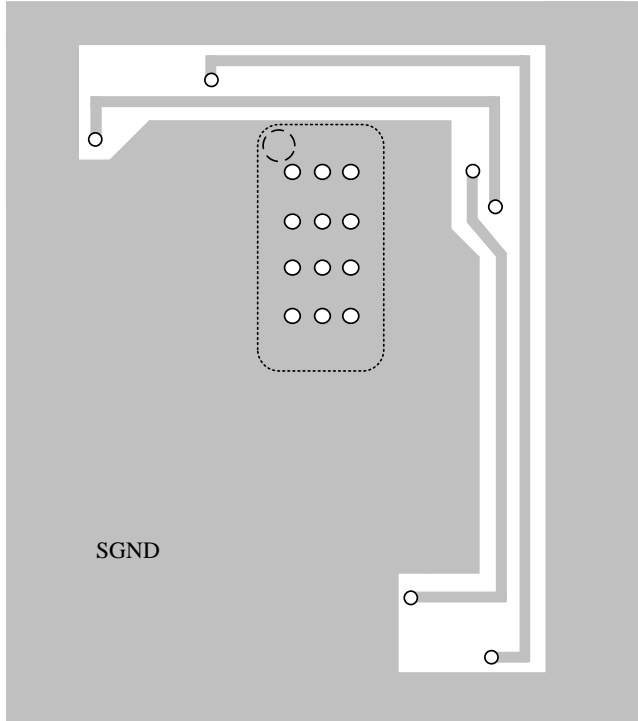

**Bottom Layer**

**Figure 6—Reference PCB Layout**

**PACKAGE INFORMATION**

**3MM X 4MM QFN14**

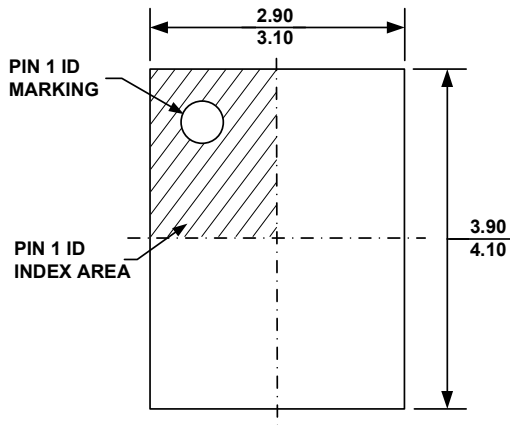

**TOP VIEW**

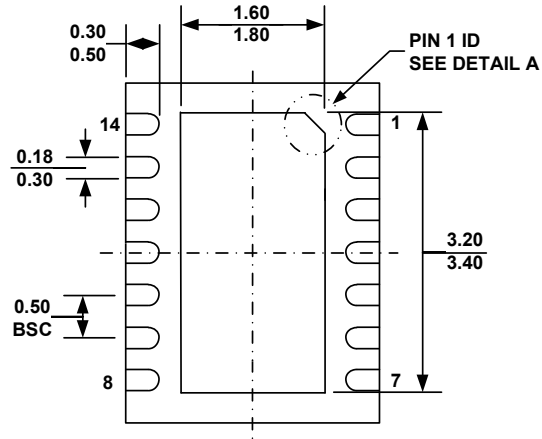

**BOTTOM VIEW**

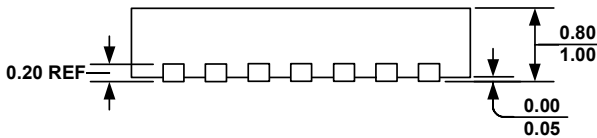

**SIDE VIEW**

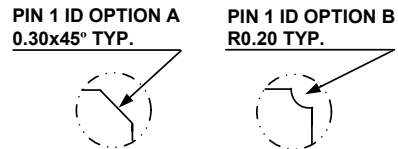

**DETAIL A**

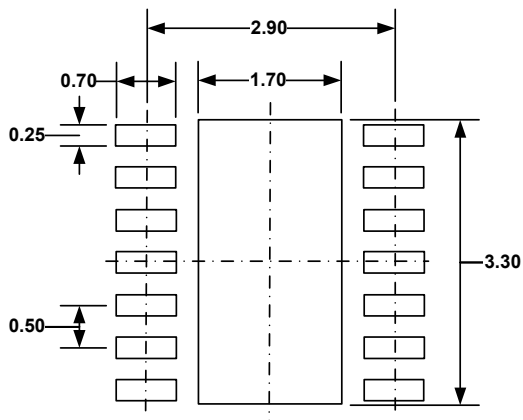

**RECOMMENDED LAND PATTERN**

**NOTE:**

- 1) ALL DIMENSIONS ARE IN MILLIMETERS.
- 2) EXPOSED PADDLE SIZE DOES NOT INCLUDE MOLD FLASH.
- 3) LEAD COPLANARITY SHALL BE 0.10 MILLIMETER MAX.
- 4) JEDEC REFERENCE IS MO-229, VARIATION VGED-3.
- 5) DRAWING IS NOT TO SCALE.

**NOTICE:** The information in this document is subject to change without notice. Users should warrant and guarantee that third party Intellectual Property rights are not infringed upon when integrating MPS products into any application. MPS will not assume any legal responsibility for any said applications.

## Looking for pricing, stock, or lifecycle information?

Click below to explore more details on WIN SOURCE:

- ⊖ [View MCP1791T-3002E/DC on WIN SOURCE](#)
- ⊖ [Microchip Technology](#) Information

## Optimize Your Supply Chain with WIN SOURCE Solutions

- ✓ Global Sourcing Solution
- ✓ Obsolete Management
- ✓ Cost Control Management
- ✓ Shortage Management
- ✓ Alternative Solution
- ✓ Excess Inventory Management