



**THE DATASHEET OF  
TPS60243DGKT**



# TPS6024x 170- $\mu$ Vrms Zero-Ripple Switched Capacitor Buck-Boost Converter for VCO Supply

## 1 Features

- Wide Input Voltage Range from 1.8 V to 5.5 V
- Regulated 2.7-V, 3-V, 3.3-V or 5-V Output Voltage With  $\pm 2.5\%$  Accuracy Over Load
- Up to 25-mA Output Current
- 170- $\mu$ Vrms Zero Ripple Output: at 20 Hz to 10 MHz Bandwidth
- Up to 90% Efficiency
- Minimum Number of External Components
  - No Inductors
  - Only Small Ceramic Chip Capacitors
- Shutdown Mode: 0.1  $\mu$ A Typical
- Thermal Protection and Current Limit
- Micro-Small 8-Pin VSSOP Package
- EVM Available TPS60241EVM-194

## 2 Applications

- VCO and PLL Power for:
  - Smart Phones
  - Mobile Phones
  - PCMCIA Modems
- Smartcard Readers
- Digital Cameras
- MP3 Players
- SIM Modules
- Electronic Games
- Memory Backup
- Handheld Meters
- Bias Supplies

## 3 Description

The TPS6024x devices are a family of switched capacitor voltage converters, ideally suited for voltage-controlled oscillator (VCO) and phase-locked loop (PLL) applications that require low noise and tight tolerances. Its dual-cap design uses four ceramic capacitors to provide ultra-low output ripple with high efficiency, while eliminating the need for inefficient linear regulators.

The TPS6024x devices operate down to 1.8 V, supporting a 3.3-V, 2.7-V, 3-V output from two-cell, nickel- or alkaline-based chemistries, whereas the TPS60241 works with 2.7-V to 5.5-V input voltage providing a 5-V output. The devices work equally well for low EMI DC-DC step-up conversion without the need for an inductor. The high switching frequency (typical 160 kHz) promotes the use of small surface-mount capacitors, saving board space. The shutdown mode of the converter conserves battery energy.

The devices are thermally protected and current-limited for reliable operation even under persisting fault conditions. Normal quiescent current (ground pin current) is only 250  $\mu$ A, and typically 0.1  $\mu$ A in shutdown mode. The TPS6024x devices come in a thin, 8-pin VSSOP package with a component height of only 1.1 mm.

### Device Information<sup>(1)</sup>

PART NUMBER	PACKAGE	OUTPUT VOLTAGE
TPS60240	VSSOP (8)	3.3 V
TPS60241		5 V
TPS60242		2.7 V
TPS60243		3 V

(1) For all available packages, see the orderable addendum at the end of the data sheet.

### Typical Application Schematic

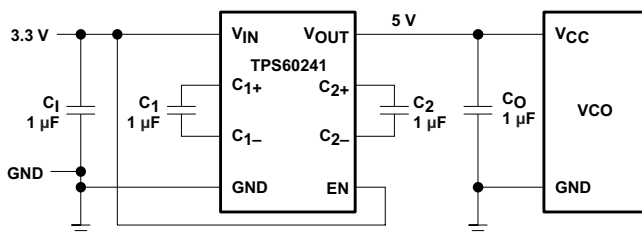

### Efficiency vs Output Current

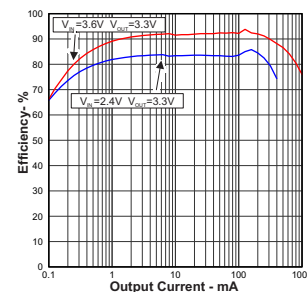

## Table of Contents

<b>1 Features</b> .....	<b>1</b>	7.4 Device Functional Modes.....	<b>8</b>
<b>2 Applications</b> .....	<b>1</b>	<b>8 Application and Implementation</b> .....	<b>9</b>
<b>3 Description</b> .....	<b>1</b>	8.1 Application Information.....	<b>9</b>
<b>4 Revision History</b> .....	<b>2</b>	8.2 Typical Applications .....	<b>9</b>
<b>5 Pin Configuration and Functions</b> .....	<b>3</b>	<b>9 Power Supply Recommendations</b> .....	<b>16</b>
<b>6 Specifications</b> .....	<b>4</b>	<b>10 Layout</b> .....	<b>16</b>
6.1 Absolute Maximum Ratings .....	<b>4</b>	10.1 Layout Guidelines .....	<b>16</b>
6.2 ESD Ratings .....	<b>4</b>	10.2 Layout Examples.....	<b>16</b>
6.3 Recommended Operating Conditions.....	<b>4</b>	<b>11 Device and Documentation Support</b> .....	<b>17</b>
6.4 Thermal Information .....	<b>4</b>	11.1 Device Support.....	<b>17</b>
6.5 Electrical Characteristics.....	<b>5</b>	11.2 Related Links .....	<b>17</b>
6.6 Typical Characteristics .....	<b>6</b>	11.3 Community Resources.....	<b>17</b>
<b>7 Detailed Description</b> .....	<b>7</b>	11.4 Trademarks .....	<b>17</b>
7.1 Overview .....	<b>7</b>	11.5 Electrostatic Discharge Caution.....	<b>17</b>
7.2 Functional Block Diagram .....	<b>7</b>	11.6 Glossary .....	<b>17</b>
7.3 Feature Description.....	<b>8</b>	<b>12 Mechanical, Packaging, and Orderable Information</b> .....	<b>17</b>

## 4 Revision History

NOTE: Page numbers for previous revisions may differ from page numbers in the current version.

### Changes from Revision B (January 2002) to Revision C

Page

- Added *Pin Configuration and Functions* section, *ESD Ratings* table, *Feature Description* section, *Device Functional Modes*, *Application and Implementation* section, *Power Supply Recommendations* section, *Layout* section, *Device and Documentation Support* section, and *Mechanical, Packaging, and Orderable Information* section .....
- C1509178 - Changed the max values for quiescent current and switching frequency. Change From:\* 325  $\mu$ A / 220 kHz; Change To:\* 400  $\mu$ A / 300 kHz .....

## 5 Pin Configuration and Functions

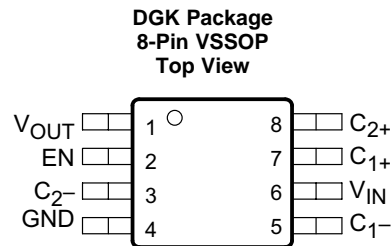

### Pin Functions

PIN		I/O	DESCRIPTION
NAME	NO.		
C <sub>1+</sub>	7	—	Positive pin of the flying capacitor C <sub>1</sub>
C <sub>1-</sub>	5	—	Negative pin of the flying capacitor C <sub>1</sub>
C <sub>2+</sub>	8	—	Positive pin of the flying capacitor C <sub>2</sub>
C <sub>2-</sub>	3	—	Negative pin of the flying capacitor C <sub>2</sub>
EN	2	I	Enable pin, active high
GND	4	—	Ground
V <sub>IN</sub>	6	I	Supply voltage input TPS60241: 2.7 V to 5.5 V, TPS60240/2/3: 1.8 V to 5.5 V. Bypass V <sub>IN</sub> to GND with a 1-μF external capacitor (C <sub>IN</sub> ).
V <sub>OUT</sub>	1	O	Regulated power output. Bypass V <sub>OUT</sub> to GND with a 1-μF external filter capacitor (C <sub>OUT</sub> ). TPS60241: regulated 5-V output, TPS60240: regulated 3.3-V output, TPS60242: regulated 2.7-V output, TPS60243: regulated 3-V output

## 6 Specifications

### 6.1 Absolute Maximum Ratings

Over operating free-air temperature range (unless otherwise noted) <sup>(1)</sup>

		MIN	MAX	UNIT
V <sub>DD</sub>	Supply voltage	-0.3	6	V
P <sub>D</sub>	Power dissipation	Internally limited		
	Voltage EN	-0.3	6	V
	Voltage C <sub>2-</sub> , C <sub>1-</sub>	-0.3	V <sub>IN</sub> or 5.5 <sup>(2)</sup>	V
	Voltage C <sub>2+</sub> , C <sub>1+</sub>	-0.3	V <sub>IN</sub> , V <sub>OUT</sub> , or 5.5 <sup>(2)</sup>	V
T <sub>J</sub>	Junction temperature		125	°C
	Short circuit output current		80	mA
T <sub>stg</sub>	Storage temperature	-65	150	°C

- (1) Stresses beyond those listed under *Absolute Maximum Ratings* may cause permanent damage to the device. These are stress ratings only, which do not imply functional operation of the device at these or any other conditions beyond those indicated under *Recommended Operating Conditions*. Exposure to absolute-maximum-rated conditions for extended periods may affect device reliability.
- (2) Whichever is lowest.

### 6.2 ESD Ratings

		VALUE	UNIT
V <sub>(ESD)</sub>	Electrostatic discharge	Human body model (HBM), per ANSI/ESDA/JEDEC JS-001 <sup>(1)</sup>	±2000
		Charged-device model (CDM), per JEDEC specification JESD22-C101 <sup>(2)</sup>	±500

- (1) JEDEC document JEP155 states that 500-V HBM allows safe manufacturing with a standard ESD control process.
- (2) JEDEC document JEP157 states that 250-V CDM allows safe manufacturing with a standard ESD control process.

### 6.3 Recommended Operating Conditions

Over operating free-air temperature range (unless otherwise noted)

			MIN	NOM	MAX	UNIT
V <sub>IN</sub>	Input voltage	TPS60240, TPS60242, TPS60243	1.8		5.5	V
		TPS60241	2.7		5.5	
I <sub>OUT</sub>	Output current	All devices		25		mA
C <sub>IN</sub>	Input capacitor			1		μF
C <sub>1</sub> , C <sub>2</sub>	Flying capacitors			1		μF
C <sub>OUT</sub>	Output capacitor			1		μF
T <sub>A</sub>	Operating temperature		-40		85	°C

### 6.4 Thermal Information

THERMAL METRIC <sup>(1)</sup>		TPS6024x	UNIT
		DGK (VSSOP)	
		8 PINS	
R <sub>θJA</sub>	Junction-to-ambient thermal resistance	174	°C/W
R <sub>θJC(top)</sub>	Junction-to-case (top) thermal resistance	66	°C/W
R <sub>θJB</sub>	Junction-to-board thermal resistance	95	°C/W
ψ <sub>JT</sub>	Junction-to-top characterization parameter	8.8	°C/W
ψ <sub>JB</sub>	Junction-to-board characterization parameter	94	°C/W
R <sub>θJC(bot)</sub>	Junction-to-case (bottom) thermal resistance	n/a	°C/W

- (1) For more information about traditional and new thermal metrics, see the *Semiconductor and IC Package Thermal Metrics* application report, [SPRA953](http://www.ti.com/lit/zip/Spra953).

## 6.5 Electrical Characteristics

For TPS6024x at  $T_A = 25^\circ\text{C}$ ,  $C_{IN} = C_{OUT} = 1\ \mu\text{F}$ ,  $C_1 = C_2 = 1\ \mu\text{F}$  (unless otherwise noted), limits apply over the specified temperature range,  $-40^\circ\text{C}$  to  $85^\circ\text{C}$ .

PARAMETER		TEST CONDITIONS	MIN	TYP	MAX	UNIT		
$V_{IN}$	Input voltage	TPS60240 assured start-up	$I_{OUT} \leq 5\ \text{mA}$ , $R_L = 600\ \Omega$		1.8	5.5	V	
		TPS60241 assured start-up	$I_{OUT} \leq 12\ \text{mA}$ , $R_L = 417\ \Omega$		2.7	5.5		
		TPS60242 assured start-up	$I_{OUT} \leq 12\ \text{mA}$ , $R_L = 225\ \Omega$		1.8	5.5		
		TPS60243 assured start-up	$I_{OUT} \leq 10\ \text{mA}$ , $R_L = 300\ \Omega$		1.8	5.5		
$V_{OUT}$	Output voltage	TPS60240	$1.8\ \text{V} \leq V_{IN} \leq 5.5\ \text{V}$ , $0\ \text{mA} \leq I_{OUT} \leq 5\ \text{mA}$		3.2175	3.3	3.3825	V
			$2.4\ \text{V} \leq V_{IN} \leq 5.5\ \text{V}$ , $0\ \text{mA} \leq I_{OUT} \leq 25\ \text{mA}$		3.2175	3.3	3.3825	
		TPS60241	$2.7\ \text{V} \leq V_{IN} \leq 5.5\ \text{V}$ , $0\ \text{mA} \leq I_{OUT} \leq 12\ \text{mA}$		4.875	5	5.125	
			$3\ \text{V} \leq V_{IN} \leq 5.5\ \text{V}$ , $0\ \text{mA} \leq I_{OUT} \leq 25\ \text{mA}$		4.875	5	5.125	
		TPS60242	$1.8\ \text{V} \leq V_{IN} \leq 5.5\ \text{V}$ , $0\ \text{mA} \leq I_{OUT} \leq 12\ \text{mA}$		2.6325	2.7	2.7675	
			$2.3\ \text{V} \leq V_{IN} \leq 5.5\ \text{V}$ , $0\ \text{mA} \leq I_{OUT} \leq 25\ \text{mA}$		2.6325	2.7	2.7675	
		TPS60243	$1.8\ \text{V} \leq V_{IN} \leq 5.5\ \text{V}$ , $0\ \text{mA} \leq I_{OUT} \leq 10\ \text{mA}$		2.925	3	3.075	
			$2.3\ \text{V} \leq V_{IN} \leq 5.5\ \text{V}$ , $0\ \text{mA} \leq I_{OUT} \leq 25\ \text{mA}$		2.925	3	3.075	
$I_{OUT}$	Output current	TPS60240/2/3	Nominal	$2\ \text{V} \leq V_{IN} \leq 5.5\ \text{V}$		12	mA	
			Short circuit	$V_{IN} = 2\ \text{V}$				80
		TPS60241	Nominal	$2.7\ \text{V} \leq V_{IN} \leq 5.5\ \text{V}$		12		
			Short circuit	$V_{IN} = 3.25\ \text{V}$				80
$f_{OSC}$	Internal clock source		100	160	300	kHz		
$V_n$	Output noise voltage	TPS60240/2/3	$V_{IN} < 2.5\ \text{V}$ , $I_{OUT} = 5\ \text{mA}$ , $\text{ESR} < 0.1\ \Omega$ , Measured over 20 Hz to 10 MHz, $C_{OUT} = 4.7\ \mu\text{F}$		170	$\mu\text{V RMS}$		
		TPS60241	$V_{IN} = 2.7\ \text{V}$ , $I_{OUT} = 5\ \text{mA}$ , $\text{ESR} < 0.1\ \Omega$ , Measured over 20 Hz to 10 MHz, $C_{OUT} = 4.7\ \mu\text{F}$		170			
$V_{IH}$	Logic high input voltage, EN		1.3		5.5	V		
$V_{IL}$	Logic low input voltage, EN		-0.2		0.4	V		
$I_{IH}$	Logic high input current, EN				100	nA		
$I_{IL}$	Logic low input current, EN				100	nA		
$t_{(EN)}$	Start-up time, EN	$V_{OUT} > 90\%$ of $V_{(NOM)}$ , $0.1\ \text{mA} \leq I_{OUT} \leq 10\ \text{mA}$ , $C_{OUT} = 1\ \mu\text{F}$		0.5		ms		
$\eta$	Efficiency	TPS60240	$I_{OUT} = 5\ \text{mA}$ , $V_{IN} = 1.8\ \text{V}$		89.6%			
		TPS60241	$I_{OUT} = 10\ \text{mA}$ , $V_{IN} = 2.7\ \text{V}$		90.8%			
		TPS60242	$I_{OUT} = 10\ \text{mA}$ , $V_{IN} = 1.8\ \text{V}$		73%			
		TPS60243	$I_{OUT} = 10\ \text{mA}$ , $V_{IN} = 1.8\ \text{V}$		81%			
$I_Q$	Quiescent current	$I_{OUT} = 0\ \text{mA}$ , $V_{IN} = 3\ \text{V}$		250	400	$\mu\text{A}$		
		In shutdown mode		0.1	1			
Thermal shutdown	Temperature activated			160		$^\circ\text{C}$		
	Temperature deactivated			140				

## 6.6 Typical Characteristics

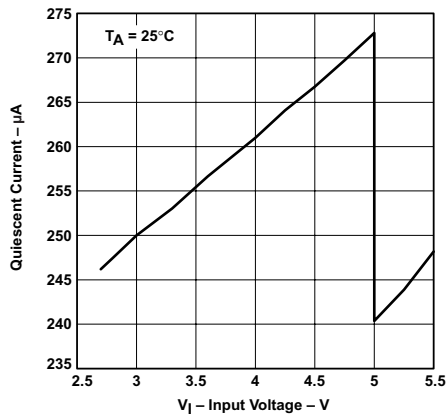

**Figure 1. TPS60241**  
Quiescent Current vs Input Voltage

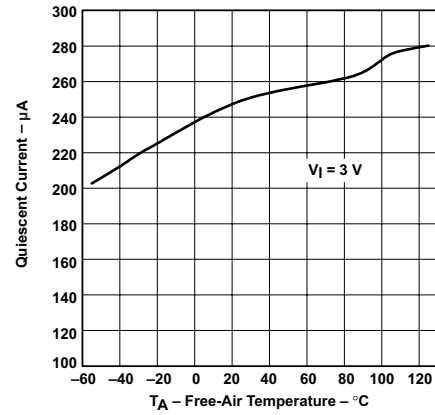

**Figure 2. TPS60241**  
Quiescent Current vs Free-Air Temperature

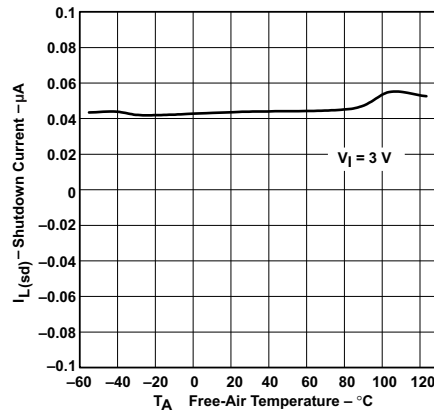

**Figure 3. TPS60241**  
Shutdown Current vs Free-Air Temperature

## 7 Detailed Description

### 7.1 Overview

The TPS6024x device is a fixed-frequency, dual-phase charge pump that provides 25 mA of continuous supply current for low-noise applications such as VCOs used in mobile phones and wireless applications.

Low-noise operation results from using a proprietary dual-phase charge pump topology that relies on an operational amplifier in the feedback loop to reduce ripple. During the first phase,  $C_1$  is charged to the supply voltage. Pin  $C_{1+}$  is connected to  $V_{IN}$ , and  $C_{1-}$  is connected to GND. In the second phase,  $C_{1-}$  is connected to the output of the operational amplifier, and  $C_{1+}$  is connected to  $V_{OUT}$ . The operational amplifier then adjusts its output until the output  $V_{OUT}$  delivers the correct voltage to make the resistor divided feedback point equal to the reference voltage. During this second phase,  $C_2$  is charged to supply voltage. Terminal  $C_{2-}$  is connected to GND, and  $C_{2+}$  is connected to  $V_{IN}$ . Phase one is then repeated with  $C_2$ , now acting to provide charge to the output in place of  $C_1$ , which is connected to the supply. The dual-phase operation lowers the output ripple voltage significantly compared to a standard single-phase charge pump. In addition, the linear feedback of the operational amplifier eliminates the ripple during discharge of the output capacitor ( $C_{OUT}$ ).

### 7.2 Functional Block Diagram

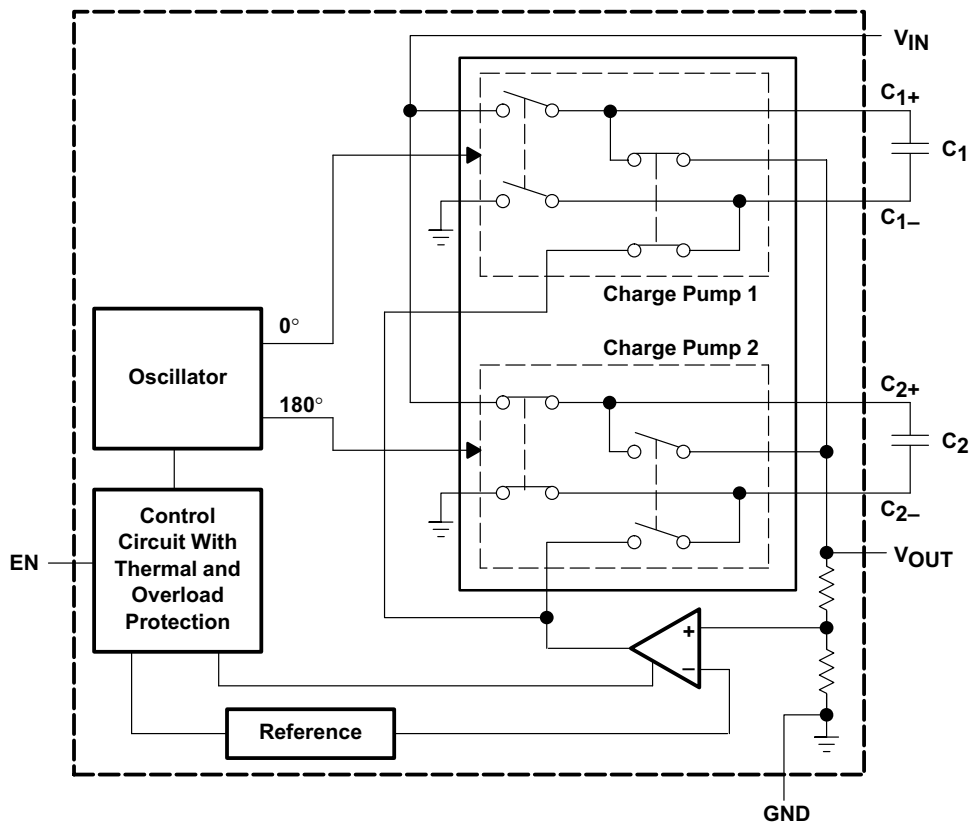

## 7.3 Feature Description

### 7.3.1 Thermal Shutdown

The TPS6024x device has a built-in thermal shutdown which turns off the power stage when the junction temperature exceeds typical 160°C. When the junction temperature drops to typical 140°C, the device starts switching again.

### 7.3.2 Current Limit

The TPS6024x device has a built-in overload protection which limits the output current.

## 7.4 Device Functional Modes

### 7.4.1 Start-up Procedure

The converter is enabled when EN is set from logic low to high. The start-up time to reach 90% of the nominal output voltage is typically 0.5 ms at load currents lower than 10 mA and with an output capacitor of 1  $\mu$ F. Increasing the values of  $C_{OUT}$  delays the start-up time.

### 7.4.2 Shutdown

Driving EN low disables the converter. This disables the internal circuits and reduces input current to typically 0.1  $\mu$ A. In this mode, the load is disconnected from the supply voltage. The device exits shutdown once EN is set to a high level.

## 8 Application and Implementation

### NOTE

Information in the following applications sections is not part of the TI component specification, and TI does not warrant its accuracy or completeness. TI's customers are responsible for determining suitability of components for their purposes. Customers should validate and test their design implementation to confirm system functionality.

### 8.1 Application Information

The TPS6024x is a switched capacitor voltage converter for VCO and PLL applications providing low noise conversion and tight tolerances. It supports regulated output voltages of 2.7 V, 3 V and 3.3 V from a 1.8-V to 5.5-V input voltage range. The TPS60241 generates 5-V output voltage from an 2.7-V to 5.5-V input voltage range.

### 8.2 Typical Applications

#### 8.2.1 5-V Low-Noise VCO Supply from 3.3-V Input

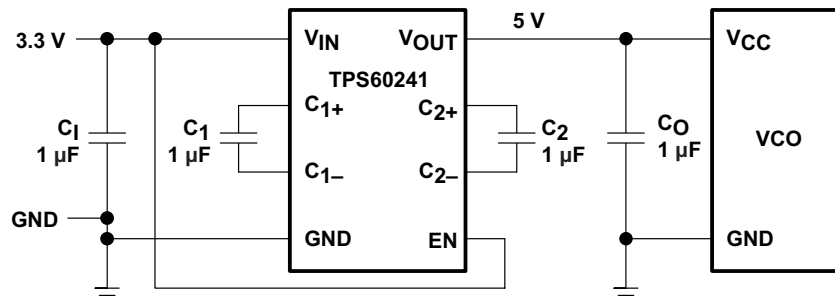

Figure 4. 5-V Low-Noise VCO Supply from 3.3-V Input

##### 8.2.1.1 Design Requirements

The complete charge pump circuitry requires no inductors and only four small ceramic capacitors.

##### 8.2.1.2 Detailed Design Procedure

###### 8.2.1.2.1 Output Voltage Ripple

The output voltage ripple depends on the capacitors used. Table 1 shows the dependence between output voltage ripple and capacitor selection.

Table 1. Output Voltage Ripple and Capacitor Selection<sup>(1)</sup>

C <sub>1</sub>	C <sub>O</sub>	C <sub>1</sub>	C <sub>2</sub>	OUTPUT VOLTAGE RIPPLE [μVrms]
1 μF	1 μF	1 μF	1 μF	288
2.2 μF	2.2 μF	1 μF	1 μF	212
4.7 μF	4.7 μF	1 μF	1 μF	183
4.7 μF	1 μF	1 μF	1 μF	272
1 μF	4.7 μF	1 μF	1 μF	185

(1) NOTE: V<sub>IN</sub> = 3.3 V, V<sub>OUT</sub> = 5 V, R<sub>L</sub> = 500 Ω, T<sub>A</sub> = 25°C

For the best output ripple performance, low-ESR ceramic capacitors are recommended (see [Table 2](#)).

**Table 2. Recommended Capacitors**

PART	MANUFACTURER	PART NUMBER	VALUE	TOLERANCE	DIELECTRIC MATERIAL	PACKAGE	RATED VOLTAGE
CI	Taiyo Yuden	LMK212BJ105KG–T	1 $\mu$ F	10%	X7R	0805	10
	TDK	C2012X5R0J475K	4.7 $\mu$ F	10%	X5R	0805	6.3
CO	Taiyo Yuden	LMK212BJ105KG–T	1 $\mu$ F	10%	X7R	0805	10
	TDK	C2012X5R0J475K	4.7 $\mu$ F	10%	X5R	0805	6.3
C1, C2	Taiyo Yuden	LMK212BJ105KG–T	1 $\mu$ F	10%	X7R	0805	10
CF	Taiyo Yuden	LMK212BJ105KG–T	1 $\mu$ F	10%	X7R	0805	10

### 8.2.1.3 Application Curves

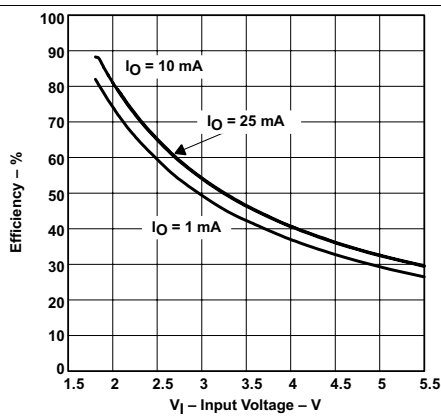

**Figure 5. TPS60240**  
Efficiency vs Input Voltage

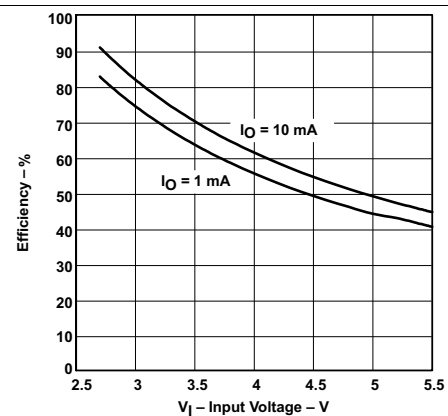

**Figure 6. TPS60241**  
Efficiency vs Input Voltage

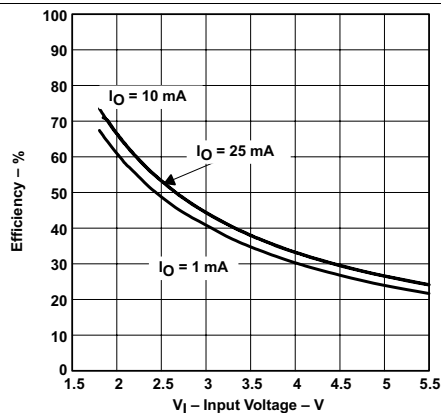

**Figure 7. TPS60242**  
Efficiency vs Input Voltage

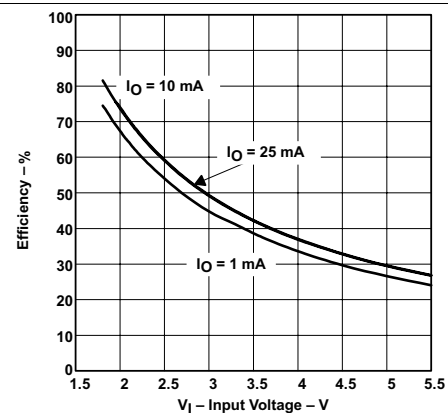

**Figure 8. TPS60243**  
Efficiency vs Input Voltage

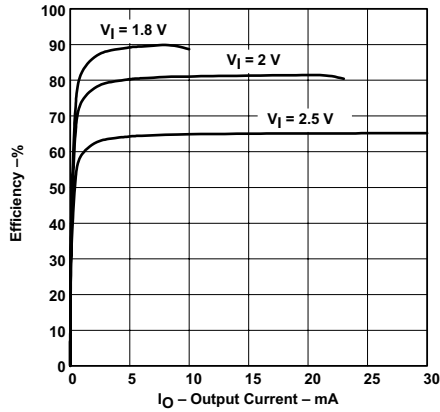

Figure 9. TPS60240  
Efficiency vs Output Voltage

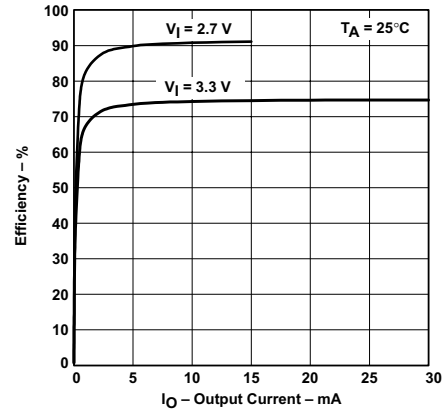

Figure 10. TPS60241  
Efficiency vs Output Voltage

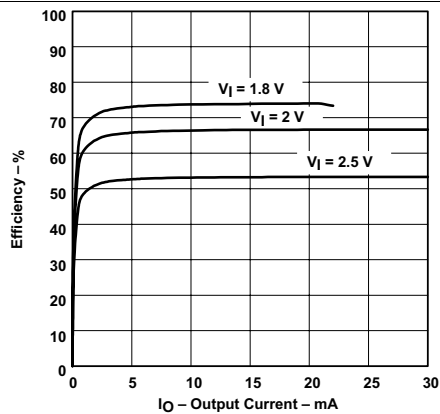

Figure 11. TPS60242  
Efficiency vs Output Voltage

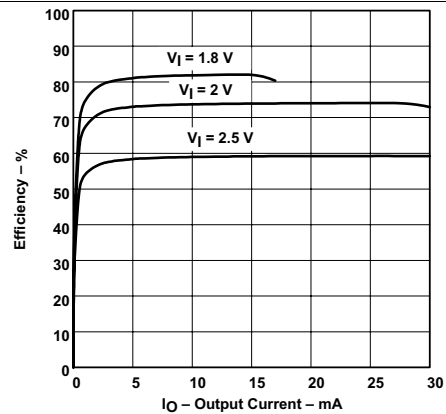

Figure 12. TPS60243  
Efficiency vs Output Voltage

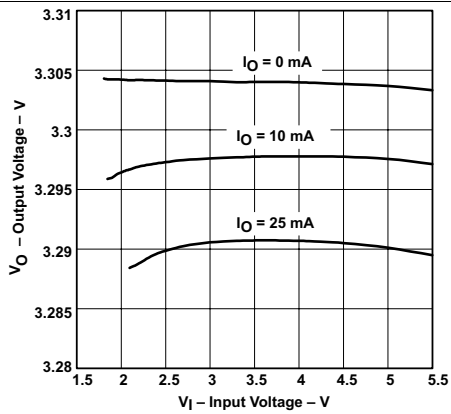

Figure 13. TPS60240  
Output Voltage vs Input Voltage

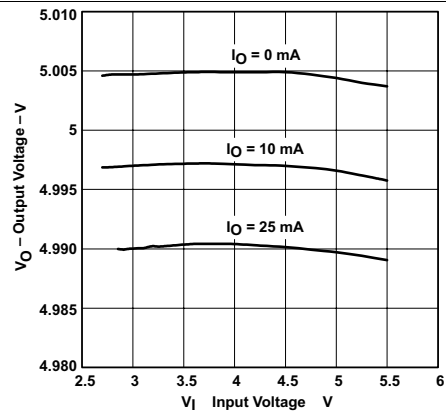
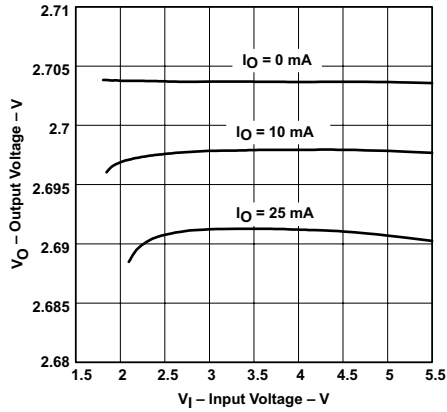
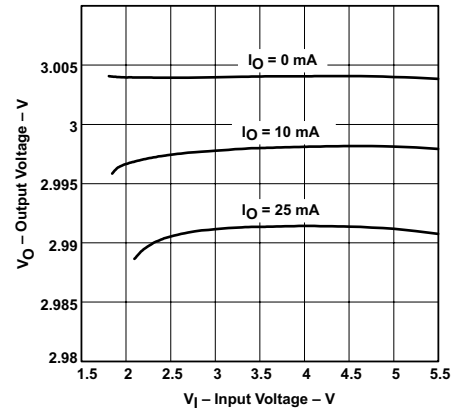

Figure 14. TPS60241  
Output Voltage vs Input Voltage



**Figure 15. TPS60242**  
Output Voltage vs Input Voltage



**Figure 16. TPS60243**  
Output Voltage vs Input Voltage

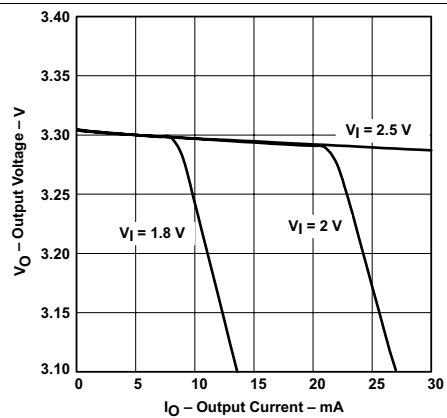

**Figure 17. TPS60240**  
Output Voltage vs Output Current

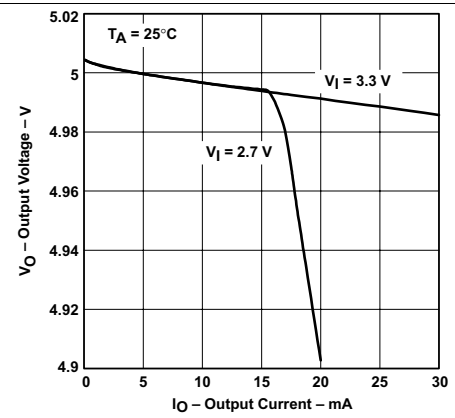

**Figure 18. TPS60241**  
Output Voltage vs Output Current

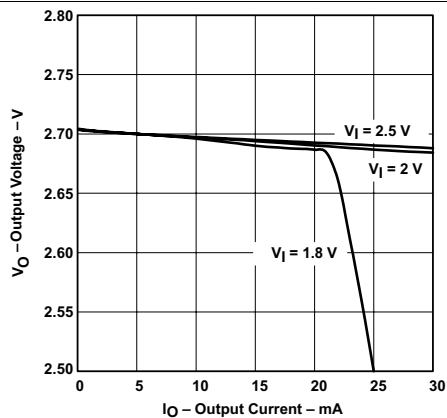

**Figure 19. TPS60242**  
Output Voltage vs Output Current

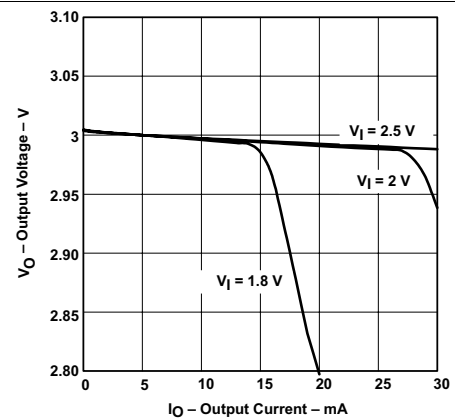

**Figure 20. TPS60243**  
Output Voltage vs Output Current

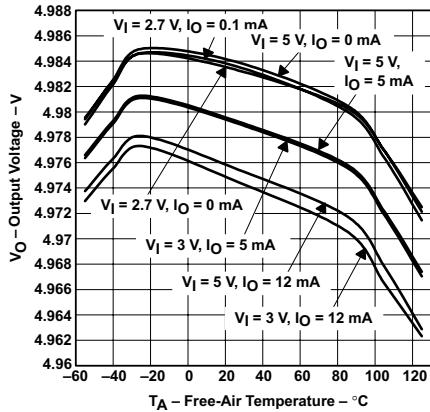

Figure 21. TPS60241  
Output Voltage vs Free-Air Temperature

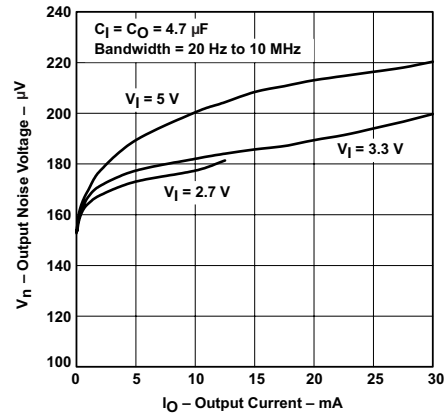

Figure 22. TPS60241  
Output Noise Voltage vs Output Current

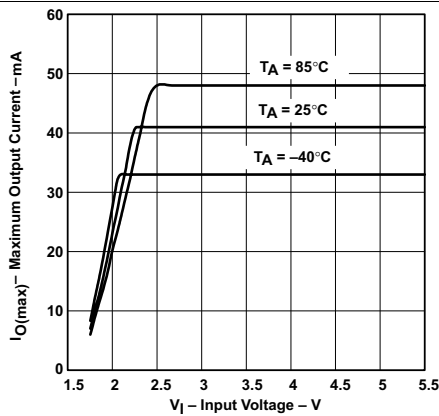

Figure 23. TPS60240  
Maximum Output Current vs Input Voltage

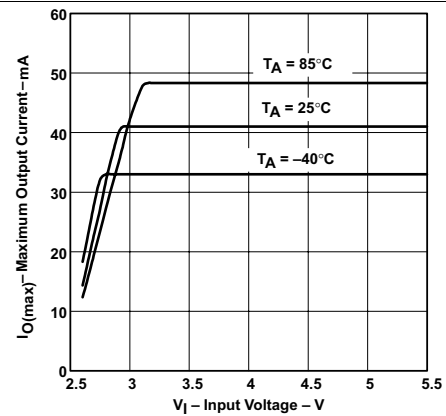

Figure 24. TPS60241  
Maximum Output Current vs Input Voltage

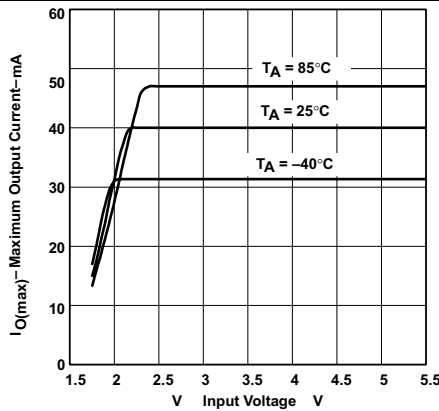

Figure 25. TPS60242  
Maximum Output Current vs Input Voltage

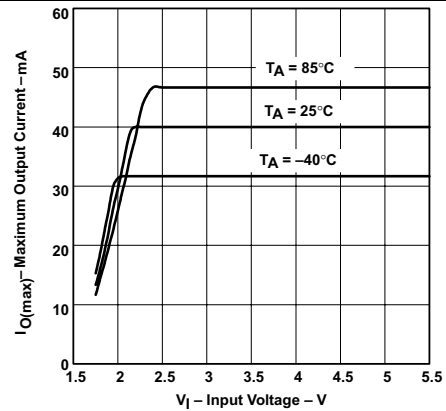

Figure 26. TPS60243  
Maximum Output Current vs Input Voltage

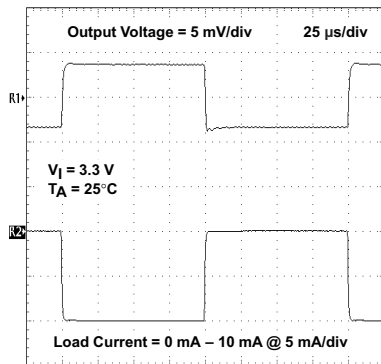

Figure 27. Load Transient Response

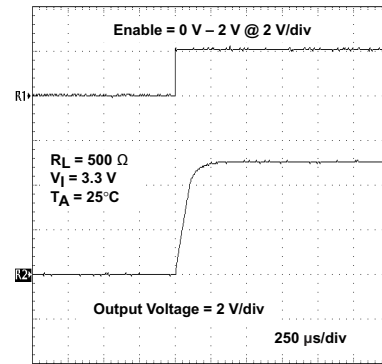

Figure 28. Start-Up Timing

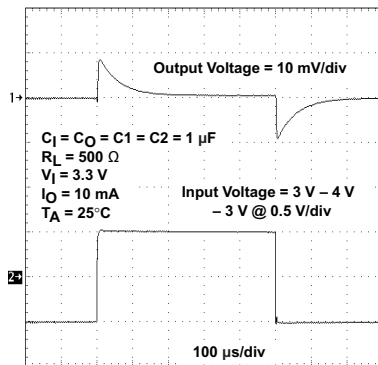

Figure 29. Line Transient Response

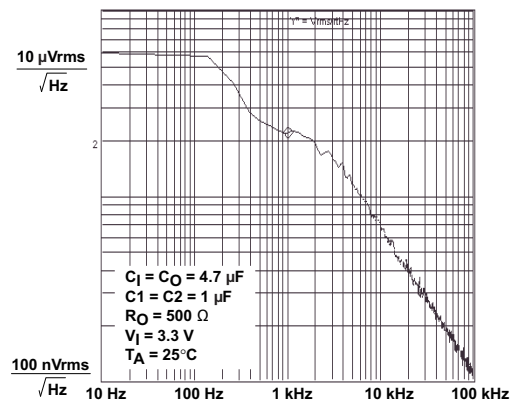
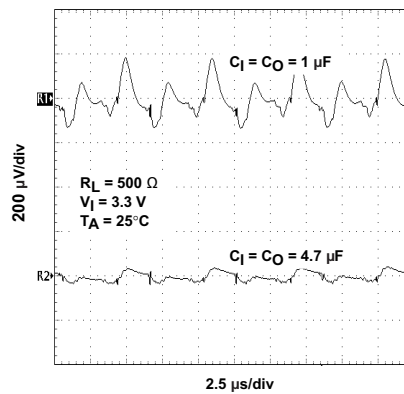

Figure 30. TPS60241 Noise Voltage Spectrum



NOTE: Scope triggered by voltage at flying capacitors, noise removed by averaging function and bandwidth limit 20 MHz.

Figure 31. TPS60241 Output Voltage Ripple vs Time

### 8.2.2 2-V to 3.3-V Low-Noise Converter

Standard application as a low noise boost converter. The device generates a regulated output voltage of 3.3 V from a 2-V supply with only 4 external 1- $\mu$ F ceramic capacitors.

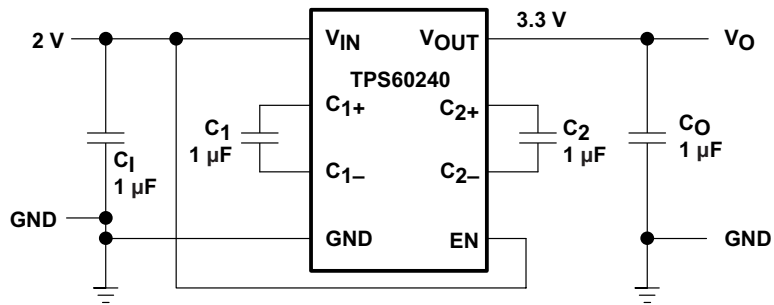

Figure 32. 2-V to 3.3-V Low-Noise Converter

## 9 Power Supply Recommendations

The TPS6024x devices have no special requirements for the input power supply. The output current of the input power supply must be rated according to the supply voltage, output voltage, and output current of the TPS6024x.

## 10 Layout

### 10.1 Layout Guidelines

To achieve optimal noise behavior, keep the power lines to the capacitors and load as short as possible. Use of power planes is recommended.

### 10.2 Layout Examples

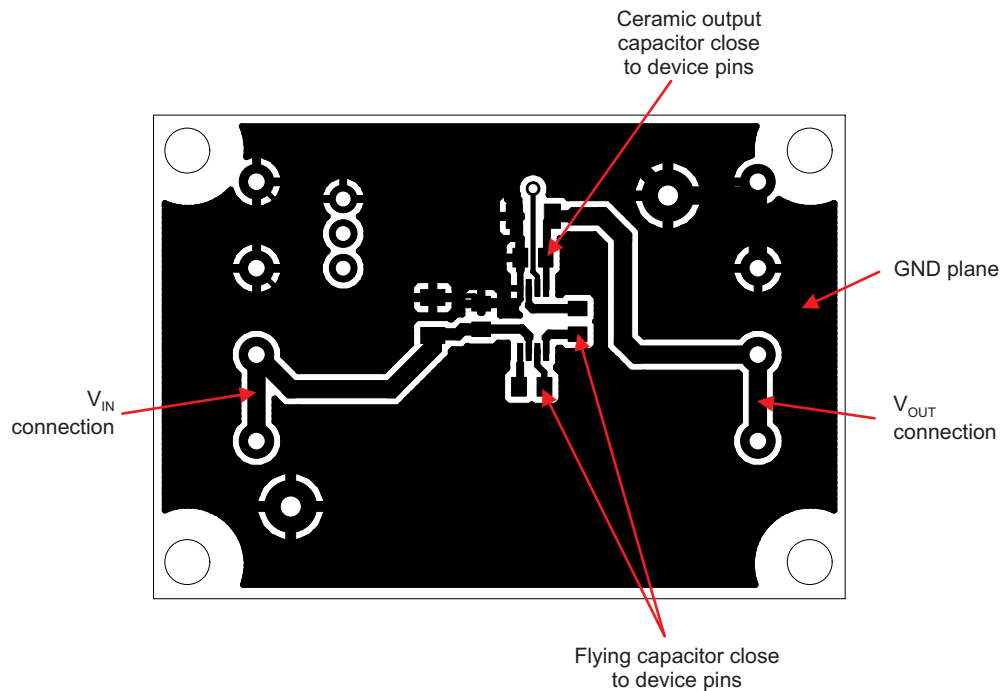

**Figure 33. Top Layer**

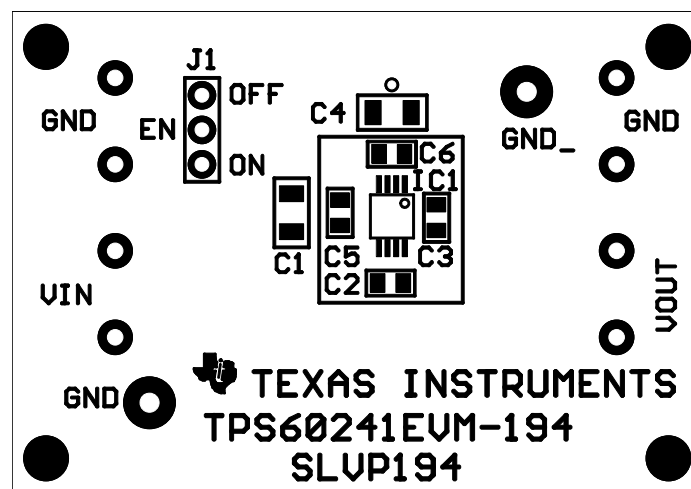

**Figure 34. Top Silkscreen**

## 11 Device and Documentation Support

### 11.1 Device Support

#### 11.1.1 Third-Party Products Disclaimer

TI'S PUBLICATION OF INFORMATION REGARDING THIRD-PARTY PRODUCTS OR SERVICES DOES NOT CONSTITUTE AN ENDORSEMENT REGARDING THE SUITABILITY OF SUCH PRODUCTS OR SERVICES OR A WARRANTY, REPRESENTATION OR ENDORSEMENT OF SUCH PRODUCTS OR SERVICES, EITHER ALONE OR IN COMBINATION WITH ANY TI PRODUCT OR SERVICE.

#### 11.2 Related Links

The table below lists quick access links. Categories include technical documents, support and community resources, tools and software, and quick access to sample or buy.

**Table 3. Related Links**

PARTS	PRODUCT FOLDER	SAMPLE & BUY	TECHNICAL DOCUMENTS	TOOLS & SOFTWARE	SUPPORT & COMMUNITY
TPS60240	<a href="#">Click here</a>	<a href="#">Click here</a>	<a href="#">Click here</a>	<a href="#">Click here</a>	<a href="#">Click here</a>
TPS60241	<a href="#">Click here</a>	<a href="#">Click here</a>	<a href="#">Click here</a>	<a href="#">Click here</a>	<a href="#">Click here</a>
TPS60242	<a href="#">Click here</a>	<a href="#">Click here</a>	<a href="#">Click here</a>	<a href="#">Click here</a>	<a href="#">Click here</a>
TPS60243	<a href="#">Click here</a>	<a href="#">Click here</a>	<a href="#">Click here</a>	<a href="#">Click here</a>	<a href="#">Click here</a>

#### 11.3 Community Resources

The following links connect to TI community resources. Linked contents are provided "AS IS" by the respective contributors. They do not constitute TI specifications and do not necessarily reflect TI's views; see TI's [Terms of Use](#).

**TI E2E™ Online Community** *TI's Engineer-to-Engineer (E2E) Community*. Created to foster collaboration among engineers. At [e2e.ti.com](http://e2e.ti.com), you can ask questions, share knowledge, explore ideas and help solve problems with fellow engineers.

**Design Support** *TI's Design Support* Quickly find helpful E2E forums along with design support tools and contact information for technical support.

#### 11.4 Trademarks

E2E is a trademark of Texas Instruments.  
All other trademarks are the property of their respective owners.

#### 11.5 Electrostatic Discharge Caution



These devices have limited built-in ESD protection. The leads should be shorted together or the device placed in conductive foam during storage or handling to prevent electrostatic damage to the MOS gates.

#### 11.6 Glossary

[SLYZ022](#) — *TI Glossary*.

This glossary lists and explains terms, acronyms, and definitions.

## 12 Mechanical, Packaging, and Orderable Information

The following pages include mechanical, packaging, and orderable information. This information is the most current data available for the designated devices. This data is subject to change without notice and revision of this document. For browser-based versions of this data sheet, refer to the left-hand navigation.

**PACKAGING INFORMATION**

Orderable Device	Status (1)	Package Type	Package Drawing	Pins	Package Qty	Eco Plan (2)	Lead/Ball Finish (6)	MSL Peak Temp (3)	Op Temp (°C)	Device Marking (4/5)	Samples
TPS60240DGKR	ACTIVE	VSSOP	DGK	8	2500	Green (RoHS & no Sb/Br)	CU NIPDAUAG	Level-2-260C-1 YEAR	-40 to 85	ATM	<a href="#">Samples</a>
TPS60240DGKT	ACTIVE	VSSOP	DGK	8	250	Green (RoHS & no Sb/Br)	CU NIPDAUAG	Level-2-260C-1 YEAR	-40 to 85	ATM	<a href="#">Samples</a>
TPS60241DGKR	ACTIVE	VSSOP	DGK	8	2500	Green (RoHS & no Sb/Br)	CU NIPDAUAG	Level-2-260C-1 YEAR	-40 to 85	AUB	<a href="#">Samples</a>
TPS60241DGKRG4	ACTIVE	VSSOP	DGK	8	2500	Green (RoHS & no Sb/Br)	CU NIPDAUAG	Level-2-260C-1 YEAR	-40 to 85	AUB	<a href="#">Samples</a>
TPS60241DGKT	ACTIVE	VSSOP	DGK	8	250	Green (RoHS & no Sb/Br)	CU NIPDAUAG	Level-2-260C-1 YEAR	-40 to 85	AUB	<a href="#">Samples</a>
TPS60242DGKT	ACTIVE	VSSOP	DGK	8	250	Green (RoHS & no Sb/Br)	CU NIPDAUAG	Level-2-260C-1 YEAR	-40 to 85	AYF	<a href="#">Samples</a>
TPS60243DGKR	ACTIVE	VSSOP	DGK	8	2500	Green (RoHS & no Sb/Br)	CU NIPDAUAG	Level-2-260C-1 YEAR	-40 to 85	AYG	<a href="#">Samples</a>
TPS60243DGKT	ACTIVE	VSSOP	DGK	8	250	Green (RoHS & no Sb/Br)	CU NIPDAUAG	Level-2-260C-1 YEAR	-40 to 85	AYG	<a href="#">Samples</a>
TPS60243DGKTG4	ACTIVE	VSSOP	DGK	8	250	Green (RoHS & no Sb/Br)	CU NIPDAUAG	Level-2-260C-1 YEAR	-40 to 85	AYG	<a href="#">Samples</a>

(1) The marketing status values are defined as follows:

**ACTIVE:** Product device recommended for new designs.

**LIFEBUY:** TI has announced that the device will be discontinued, and a lifetime-buy period is in effect.

**NRND:** Not recommended for new designs. Device is in production to support existing customers, but TI does not recommend using this part in a new design.

**PREVIEW:** Device has been announced but is not in production. Samples may or may not be available.

**OBSOLETE:** TI has discontinued the production of the device.

(2) **RoHS:** TI defines "RoHS" to mean semiconductor products that are compliant with the current EU RoHS requirements for all 10 RoHS substances, including the requirement that RoHS substance do not exceed 0.1% by weight in homogeneous materials. Where designed to be soldered at high temperatures, "RoHS" products are suitable for use in specified lead-free processes. TI may reference these types of products as "Pb-Free".

**RoHS Exempt:** TI defines "RoHS Exempt" to mean products that contain lead but are compliant with EU RoHS pursuant to a specific EU RoHS exemption.

**Green:** TI defines "Green" to mean the content of Chlorine (Cl) and Bromine (Br) based flame retardants meet JS709B low halogen requirements of <=1000ppm threshold. Antimony trioxide based flame retardants must also meet the <=1000ppm threshold requirement.

(3) MSL, Peak Temp. - The Moisture Sensitivity Level rating according to the JEDEC industry standard classifications, and peak solder temperature.

(4) There may be additional marking, which relates to the logo, the lot trace code information, or the environmental category on the device.

(5) Multiple Device Markings will be inside parentheses. Only one Device Marking contained in parentheses and separated by a "~" will appear on a device. If a line is indented then it is a continuation of the previous line and the two combined represent the entire Device Marking for that device.

(6) Lead/Ball Finish - Orderable Devices may have multiple material finish options. Finish options are separated by a vertical ruled line. Lead/Ball Finish values may wrap to two lines if the finish value exceeds the maximum column width.

**Important Information and Disclaimer:**The information provided on this page represents TI's knowledge and belief as of the date that it is provided. TI bases its knowledge and belief on information provided by third parties, and makes no representation or warranty as to the accuracy of such information. Efforts are underway to better integrate information from third parties. TI has taken and continues to take reasonable steps to provide representative and accurate information but may not have conducted destructive testing or chemical analysis on incoming materials and chemicals. TI and TI suppliers consider certain information to be proprietary, and thus CAS numbers and other limited information may not be available for release.

In no event shall TI's liability arising out of such information exceed the total purchase price of the TI part(s) at issue in this document sold by TI to Customer on an annual basis.

**TAPE AND REEL INFORMATION**

**QUADRANT ASSIGNMENTS FOR PIN 1 ORIENTATION IN TAPE**

\*All dimensions are nominal

Device	Package Type	Package Drawing	Pins	SPQ	Reel Diameter (mm)	Reel Width W1 (mm)	A0 (mm)	B0 (mm)	K0 (mm)	P1 (mm)	W (mm)	Pin1 Quadrant
TPS60240DGKR	VSSOP	DGK	8	2500	330.0	12.4	5.3	3.4	1.4	8.0	12.0	Q1
TPS60240DGKT	VSSOP	DGK	8	250	330.0	12.4	5.3	3.4	1.4	8.0	12.0	Q1
TPS60241DGKR	VSSOP	DGK	8	2500	330.0	12.4	5.3	3.4	1.4	8.0	12.0	Q1
TPS60241DGKT	VSSOP	DGK	8	250	330.0	12.4	5.3	3.4	1.4	8.0	12.0	Q1
TPS60242DGKT	VSSOP	DGK	8	250	330.0	12.4	5.3	3.4	1.4	8.0	12.0	Q1
TPS60243DGKR	VSSOP	DGK	8	2500	330.0	12.4	5.3	3.4	1.4	8.0	12.0	Q1
TPS60243DGKT	VSSOP	DGK	8	250	330.0	12.4	5.3	3.4	1.4	8.0	12.0	Q1

**TAPE AND REEL BOX DIMENSIONS**

\*All dimensions are nominal

Device	Package Type	Package Drawing	Pins	SPQ	Length (mm)	Width (mm)	Height (mm)
TPS60240DGKR	VSSOP	DGK	8	2500	366.0	364.0	50.0
TPS60240DGKT	VSSOP	DGK	8	250	366.0	364.0	50.0
TPS60241DGKR	VSSOP	DGK	8	2500	366.0	364.0	50.0
TPS60241DGKT	VSSOP	DGK	8	250	366.0	364.0	50.0
TPS60242DGKT	VSSOP	DGK	8	250	366.0	364.0	50.0
TPS60243DGKR	VSSOP	DGK	8	2500	366.0	364.0	50.0
TPS60243DGKT	VSSOP	DGK	8	250	366.0	364.0	50.0

## IMPORTANT NOTICE

Texas Instruments Incorporated (TI) reserves the right to make corrections, enhancements, improvements and other changes to its semiconductor products and services per JESD46, latest issue, and to discontinue any product or service per JESD48, latest issue. Buyers should obtain the latest relevant information before placing orders and should verify that such information is current and complete.

TI's published terms of sale for semiconductor products (<http://www.ti.com/sc/docs/stdterms.htm>) apply to the sale of packaged integrated circuit products that TI has qualified and released to market. Additional terms may apply to the use or sale of other types of TI products and services.

Reproduction of significant portions of TI information in TI data sheets is permissible only if reproduction is without alteration and is accompanied by all associated warranties, conditions, limitations, and notices. TI is not responsible or liable for such reproduced documentation. Information of third parties may be subject to additional restrictions. Resale of TI products or services with statements different from or beyond the parameters stated by TI for that product or service voids all express and any implied warranties for the associated TI product or service and is an unfair and deceptive business practice. TI is not responsible or liable for any such statements.

Buyers and others who are developing systems that incorporate TI products (collectively, "Designers") understand and agree that Designers remain responsible for using their independent analysis, evaluation and judgment in designing their applications and that Designers have full and exclusive responsibility to assure the safety of Designers' applications and compliance of their applications (and of all TI products used in or for Designers' applications) with all applicable regulations, laws and other applicable requirements. Designer represents that, with respect to their applications, Designer has all the necessary expertise to create and implement safeguards that (1) anticipate dangerous consequences of failures, (2) monitor failures and their consequences, and (3) lessen the likelihood of failures that might cause harm and take appropriate actions. Designer agrees that prior to using or distributing any applications that include TI products, Designer will thoroughly test such applications and the functionality of such TI products as used in such applications.

TI's provision of technical, application or other design advice, quality characterization, reliability data or other services or information, including, but not limited to, reference designs and materials relating to evaluation modules, (collectively, "TI Resources") are intended to assist designers who are developing applications that incorporate TI products; by downloading, accessing or using TI Resources in any way, Designer (individually or, if Designer is acting on behalf of a company, Designer's company) agrees to use any particular TI Resource solely for this purpose and subject to the terms of this Notice.

TI's provision of TI Resources does not expand or otherwise alter TI's applicable published warranties or warranty disclaimers for TI products, and no additional obligations or liabilities arise from TI providing such TI Resources. TI reserves the right to make corrections, enhancements, improvements and other changes to its TI Resources. TI has not conducted any testing other than that specifically described in the published documentation for a particular TI Resource.

Designer is authorized to use, copy and modify any individual TI Resource only in connection with the development of applications that include the TI product(s) identified in such TI Resource. NO OTHER LICENSE, EXPRESS OR IMPLIED, BY ESTOPPEL OR OTHERWISE TO ANY OTHER TI INTELLECTUAL PROPERTY RIGHT, AND NO LICENSE TO ANY TECHNOLOGY OR INTELLECTUAL PROPERTY RIGHT OF TI OR ANY THIRD PARTY IS GRANTED HEREIN, including but not limited to any patent right, copyright, mask work right, or other intellectual property right relating to any combination, machine, or process in which TI products or services are used. Information regarding or referencing third-party products or services does not constitute a license to use such products or services, or a warranty or endorsement thereof. Use of TI Resources may require a license from a third party under the patents or other intellectual property of the third party, or a license from TI under the patents or other intellectual property of TI.

TI RESOURCES ARE PROVIDED "AS IS" AND WITH ALL FAULTS. TI DISCLAIMS ALL OTHER WARRANTIES OR REPRESENTATIONS, EXPRESS OR IMPLIED, REGARDING RESOURCES OR USE THEREOF, INCLUDING BUT NOT LIMITED TO ACCURACY OR COMPLETENESS, TITLE, ANY EPIDEMIC FAILURE WARRANTY AND ANY IMPLIED WARRANTIES OF MERCHANTABILITY, FITNESS FOR A PARTICULAR PURPOSE, AND NON-INFRINGEMENT OF ANY THIRD PARTY INTELLECTUAL PROPERTY RIGHTS. TI SHALL NOT BE LIABLE FOR AND SHALL NOT DEFEND OR INDEMNIFY DESIGNER AGAINST ANY CLAIM, INCLUDING BUT NOT LIMITED TO ANY INFRINGEMENT CLAIM THAT RELATES TO OR IS BASED ON ANY COMBINATION OF PRODUCTS EVEN IF DESCRIBED IN TI RESOURCES OR OTHERWISE. IN NO EVENT SHALL TI BE LIABLE FOR ANY ACTUAL, DIRECT, SPECIAL, COLLATERAL, INDIRECT, PUNITIVE, INCIDENTAL, CONSEQUENTIAL OR EXEMPLARY DAMAGES IN CONNECTION WITH OR ARISING OUT OF TI RESOURCES OR USE THEREOF, AND REGARDLESS OF WHETHER TI HAS BEEN ADVISED OF THE POSSIBILITY OF SUCH DAMAGES.

Unless TI has explicitly designated an individual product as meeting the requirements of a particular industry standard (e.g., ISO/TS 16949 and ISO 26262), TI is not responsible for any failure to meet such industry standard requirements.

Where TI specifically promotes products as facilitating functional safety or as compliant with industry functional safety standards, such products are intended to help enable customers to design and create their own applications that meet applicable functional safety standards and requirements. Using products in an application does not by itself establish any safety features in the application. Designers must ensure compliance with safety-related requirements and standards applicable to their applications. Designer may not use any TI products in life-critical medical equipment unless authorized officers of the parties have executed a special contract specifically governing such use. Life-critical medical equipment is medical equipment where failure of such equipment would cause serious bodily injury or death (e.g., life support, pacemakers, defibrillators, heart pumps, neurostimulators, and implantables). Such equipment includes, without limitation, all medical devices identified by the U.S. Food and Drug Administration as Class III devices and equivalent classifications outside the U.S.

TI may expressly designate certain products as completing a particular qualification (e.g., Q100, Military Grade, or Enhanced Product). Designers agree that it has the necessary expertise to select the product with the appropriate qualification designation for their applications and that proper product selection is at Designers' own risk. Designers are solely responsible for compliance with all legal and regulatory requirements in connection with such selection.

Designer will fully indemnify TI and its representatives against any damages, costs, losses, and/or liabilities arising out of Designer's non-compliance with the terms and provisions of this Notice.

## Looking for pricing, stock, or lifecycle information?

Click below to explore more details on WIN SOURCE:

 [View TPS60243DGKT](#) on WIN SOURCE

 [Texas Instruments](#) Information

## Optimize Your Supply Chain with WIN SOURCE Solutions

-  Global Sourcing Solution
-  Obsolete Management
-  Cost Control Management
-  Shortage Management
-  Alternative Solution
-  Excess Inventory Management