



# THE DATASHEET OF STPSC1206D



## 600 V power Schottky silicon carbide diode

### Features

- No reverse recovery
- Switching behavior independent of temperature
- Dedicated to PFC boost diode

### Description

These diodes are manufactured using silicon carbide substrate. This wide bandgap material supports the manufacture of a Schottky diode structure with a high voltage rating. Such diodes exhibit no or negligible recovery characteristics. The recovery characteristics are independent of the temperature.

Using these diodes will significantly reduce the switching power losses of the associated MOS-FET, and thus increase the efficiency of the overall application. These diodes will then outperform the power factor correction circuit operating in hard switching conditions.

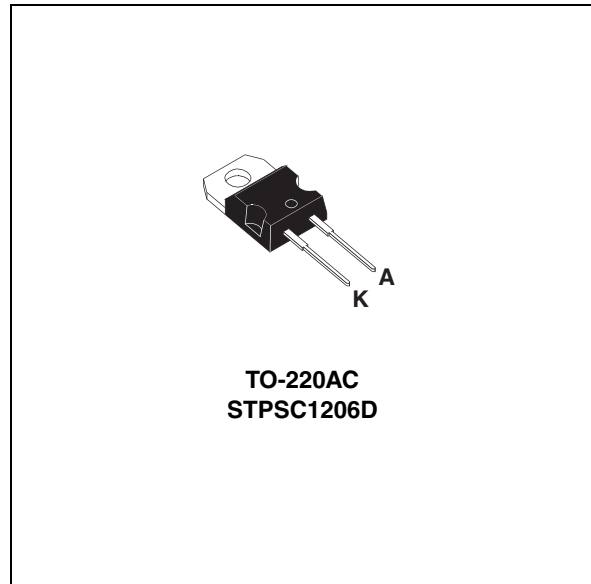

**Table 1. Device summary**

$I_{F(AV)}$	12 A
$V_{RRM}$	600 V
$T_j(max)$	175 °C
$Q_C(typ)$	12 nC

# 1 Characteristics

**Table 2. Absolute ratings (limiting values at 25 °C unless otherwise specified)**

Symbol	Parameter		Value	Unit
$V_{RRM}$	Repetitive peak reverse voltage		600	V
$I_{F(RMS)}$	Forward rms current		30	A
$I_{F(AV)}$	Average forward current	$T_c = 110\text{ °C}, \delta = 0.5$	12	A
$I_{FSM}$	Surge non repetitive forward current	$t_p = 10\text{ ms sinusoidal}, T_c = 25\text{ °C}$	50	A
		$t_p = 10\text{ ms sinusoidal}, T_c = 125\text{ °C}$	40	
		$t_p = 10\text{ }\mu\text{s square}, T_c = 25\text{ °C}$	200	
$I_{FRM}$	Repetitive peak forward current	$T_c = 105\text{ °C}, T_j = 150\text{ °C}, \delta = 0.1$	50	A
$T_{stg}$	Storage temperature range		-55 to +175	°C
$T_j$	Operating junction temperature		-40 to +175	°C

**Table 3. Thermal resistance**

Symbol	Parameter	Maximum value	Unit
$R_{th(j-c)}$	Junction to case	1.75	°C/W

**Table 4. Static electrical characteristics**

Symbol	Parameter	Tests conditions		Min.	Typ.	Max.	Unit
$I_R^{(1)}$	Reverse leakage current	$T_j = 25\text{ °C}$	$V_R = V_{RRM}$	-	30	150	$\mu\text{A}$
		$T_j = 150\text{ °C}$		-	200	1500	
$V_F^{(2)}$	Forward voltage drop	$T_j = 25\text{ °C}$	$I_F = 12\text{ A}$	-	1.4	1.7	V
		$T_j = 150\text{ °C}$		-	1.6	2.1	

1.  $t_p = 10\text{ ms}, \delta < 2\%$

2.  $t_p = 500\text{ }\mu\text{s}, \delta < 2\%$

To evaluate the conduction losses use the following equation:

$$P = 1.2 \times I_{F(AV)} + 0.075 \times I_{F(RMS)}^2$$

**Table 5. Other parameters**

Symbol	Parameter	Test conditions	Typ.	Unit
$Q_c$	Total capacitive charge	$V_r = 400\text{ V}, I_F = 12\text{ A}$ $di_F/dt = -200\text{ A}/\mu\text{s}, T_j = 150\text{ °C}$	12	nC
C	Total capacitance	$V_r = 0\text{ V}, T_c = 25\text{ °C}, F = 1\text{ Mhz}$	750	pF
		$V_r = 400\text{ V}, T_c = 25\text{ °C}, F = 1\text{ Mhz}$	65	

**Figure 1. Forward voltage drop versus forward current (typical values)**

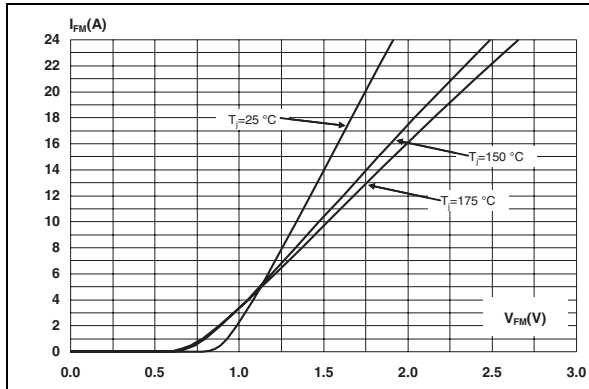

**Figure 2. Reverse leakage current versus reverse voltage applied (maximum values)**

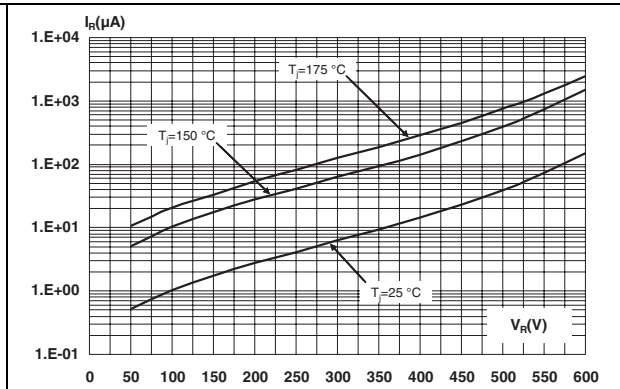

**Figure 3. Peak forward current versus case temperature**

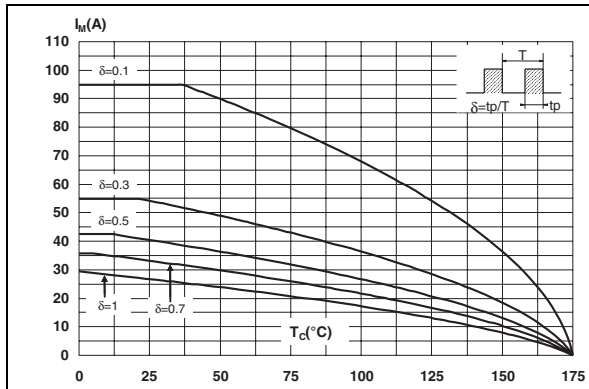

**Figure 4. Junction capacitance versus reverse voltage applied (typical values)**

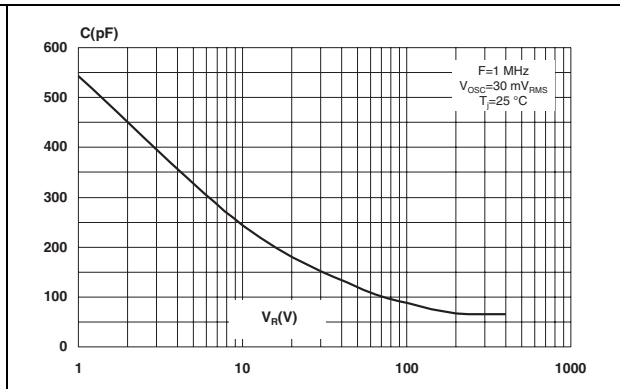

**Figure 5. Relative variation of thermal impedance junction to case versus pulse duration**

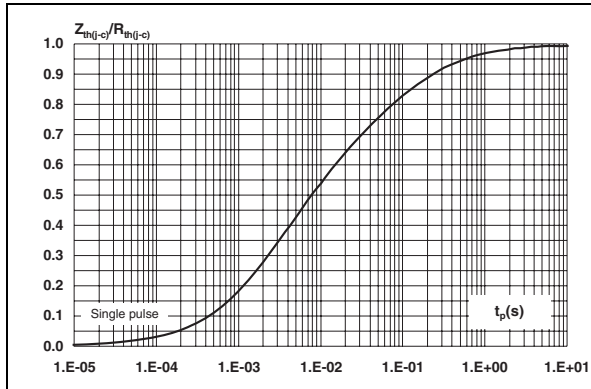

**Figure 6. Non-repetitive peak surge forward current versus pulse duration (sinusoidal waveform)**

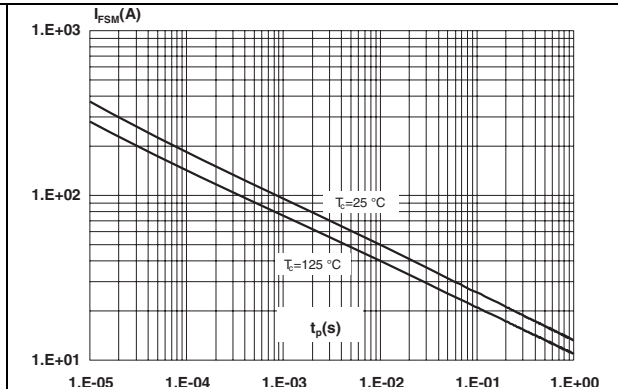

**Figure 7. Total capacitive charges versus  $di_F/dt$  (typical values)**

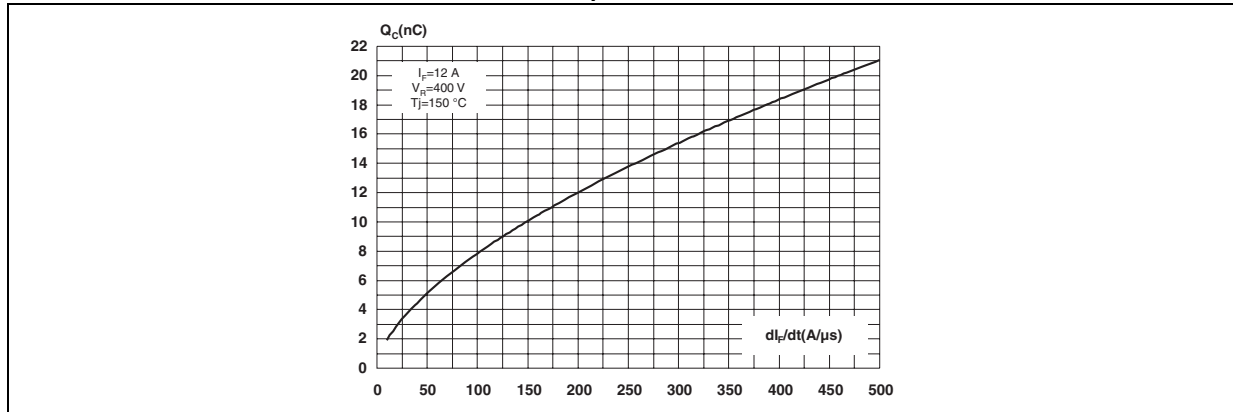

## 2 Package information

- Epoxy meets UL94, V0
- Colling method: convection (C)
- Recommended torque: 0.4 to 0.6 N·m

In order to meet environmental requirements, ST offers these devices in different grades of ECOPACK® packages, depending on their level of environmental compliance. ECOPACK® specifications, grade definitions and product status are available at: [www.st.com](http://www.st.com). ECOPACK® is an ST trademark.

**Table 6. TO-220AC dimensions**

Ref.	Dimensions			
	Millimeters		Inches	
	Min.	Max.	Min.	Max.
A	4.40	4.60	0.173	0.181
C	1.23	1.32	0.048	0.051
D	2.40	2.72	0.094	0.107
E	0.49	0.70	0.019	0.027
F	0.61	0.88	0.024	0.034
F1	1.14	1.70	0.044	0.066
G	4.95	5.15	0.194	0.202
H2	10.00	10.40	0.393	0.409
L2	16.40 typ.		0.645 typ.	
L4	13.00	14.00	0.511	0.551
L5	2.65	2.95	0.104	0.116
L6	15.25	15.75	0.600	0.620
L7	6.20	6.60	0.244	0.259
L9	3.50	3.93	0.137	0.154
M	2.6 typ.		0.102 typ.	
Diam. I	3.75	3.85	0.147	0.151

### 3 Ordering information

Table 7. Ordering information

Order code	Marking	Package	Weight	Base qty	Delivery mode
STPSC1206D	STPSC1206D	TO-220AC	1.86 g	50	Tube

### 4 Revision history

Table 8. Document revision history

Date	Revision	Changes
28-Sep-2009	1	First issue.

**Please Read Carefully:**

Information in this document is provided solely in connection with ST products. STMicroelectronics NV and its subsidiaries ("ST") reserve the right to make changes, corrections, modifications or improvements, to this document, and the products and services described herein at any time, without notice.

All ST products are sold pursuant to ST's terms and conditions of sale.

Purchasers are solely responsible for the choice, selection and use of the ST products and services described herein, and ST assumes no liability whatsoever relating to the choice, selection or use of the ST products and services described herein.

No license, express or implied, by estoppel or otherwise, to any intellectual property rights is granted under this document. If any part of this document refers to any third party products or services it shall not be deemed a license grant by ST for the use of such third party products or services, or any intellectual property contained therein or considered as a warranty covering the use in any manner whatsoever of such third party products or services or any intellectual property contained therein.

**UNLESS OTHERWISE SET FORTH IN ST'S TERMS AND CONDITIONS OF SALE ST DISCLAIMS ANY EXPRESS OR IMPLIED WARRANTY WITH RESPECT TO THE USE AND/OR SALE OF ST PRODUCTS INCLUDING WITHOUT LIMITATION IMPLIED WARRANTIES OF MERCHANTABILITY, FITNESS FOR A PARTICULAR PURPOSE (AND THEIR EQUIVALENTS UNDER THE LAWS OF ANY JURISDICTION), OR INFRINGEMENT OF ANY PATENT, COPYRIGHT OR OTHER INTELLECTUAL PROPERTY RIGHT.**

**UNLESS EXPRESSLY APPROVED IN WRITING BY AN AUTHORIZED ST REPRESENTATIVE, ST PRODUCTS ARE NOT RECOMMENDED, AUTHORIZED OR WARRANTED FOR USE IN MILITARY, AIR CRAFT, SPACE, LIFE SAVING, OR LIFE SUSTAINING APPLICATIONS, NOR IN PRODUCTS OR SYSTEMS WHERE FAILURE OR MALFUNCTION MAY RESULT IN PERSONAL INJURY, DEATH, OR SEVERE PROPERTY OR ENVIRONMENTAL DAMAGE. ST PRODUCTS WHICH ARE NOT SPECIFIED AS "AUTOMOTIVE GRADE" MAY ONLY BE USED IN AUTOMOTIVE APPLICATIONS AT USER'S OWN RISK.**

Resale of ST products with provisions different from the statements and/or technical features set forth in this document shall immediately void any warranty granted by ST for the ST product or service described herein and shall not create or extend in any manner whatsoever, any liability of ST.

ST and the ST logo are trademarks or registered trademarks of ST in various countries.

Information in this document supersedes and replaces all information previously supplied.

The ST logo is a registered trademark of STMicroelectronics. All other names are the property of their respective owners.

© 2009 STMicroelectronics - All rights reserved



STMicroelectronics group of companies

Australia - Belgium - Brazil - Canada - China - Czech Republic - Finland - France - Germany - Hong Kong - India - Israel - Italy - Japan - Malaysia - Malta - Morocco - Philippines - Singapore - Spain - Sweden - Switzerland - United Kingdom - United States of America

[www.st.com](http://www.st.com)

## Looking for pricing, stock, or lifecycle information?

Click below to explore more details on WIN SOURCE:

-  [View STPSC1206D on WIN SOURCE](#)
-  [STMicroelectronics Information](#)

## Optimize Your Supply Chain with WIN SOURCE Solutions

-  Global Sourcing Solution
-  Obsolete Management
-  Cost Control Management
-  Shortage Management
-  Alternative Solution
-  Excess Inventory Management