



THE DATASHEET OF TLC545IFN



TLC545C, TLC545I, TLC546C, TLC546I 8-BIT ANALOG-TO-DIGITAL CONVERTERS WITH SERIAL CONTROL AND 19 INPUTS

SLAS066B – DECEMBER 1985 – REVISED OCTOBER 1996

- 8-Bit Resolution A/D Converter
- Microprocessor Peripheral or Stand-Alone Operation
- On-Chip 20-Channel Analog Multiplexer
- Built-in Self-Test Mode
- Software-Controllable Sample and Hold
- Total Unadjusted Error . . . ± 0.5 LSB Max
- Timing and Control Signals Compatible With 8-Bit TLC540 and 10-Bit TLC1540 A/D Converter Families
- CMOS Technology

PARAMETER	TL545	TL546
Channel Acquisition Time	1.5 μ s	2.7 μ s
Conversion Time (Max)	9 μ s	17 μ s
Sampling Rate (Max)	76 x 10 ³	40 x 10 ³
Power Dissipation (Max)	15 mW	15 mW

description

The TLC545 and TLC546 are CMOS analog-to-digital converters built around an 8-bit switched capacitor successive-approximation analog-to-digital converter. They are designed for serial interface to a microprocessor or peripheral via a 3-state output with up to four control inputs including independent SYSTEM CLOCK, I/O CLOCK, chip select (\overline{CS}), and ADDRESS INPUT. A 4-MHz system clock for the TLC545 and a 2.1-MHz system clock for the TLC546 with a design that includes simultaneous read/write operation allowing high-speed data transfers and sample rates of up to 76,923 samples per second for the TLC545, and 40,000 samples per second for the TLC546.

In addition to the high-speed converter and versatile control logic, there is an on-chip 20-channel analog multiplexer that can be used to sample any one of 19 inputs or an internal self-test voltage, and a sample-and-hold that can operate automatically or under microprocessor control.

The converters incorporated in the TLC545 and TLC546 feature differential high-impedance reference inputs that facilitate ratiometric conversion, scaling, and analog circuitry isolation from logic and supply noises. A totally switched capacitor design allows low-error (± 0.5 LSB) conversion in 9 μ s for the TLC545, and 17 μ s for the TLC546, over the full operating temperature range.

N PACKAGE
(TOP VIEW)

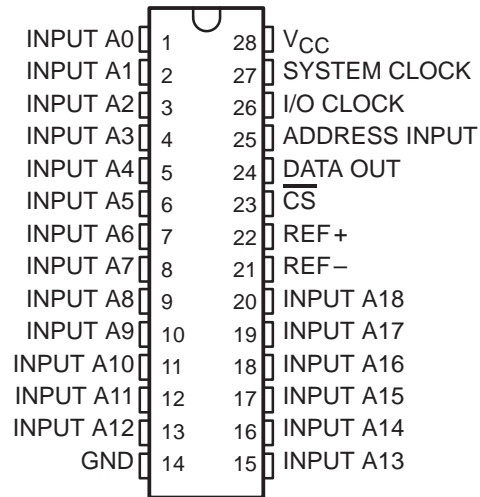

FN PACKAGE
(TOP VIEW)

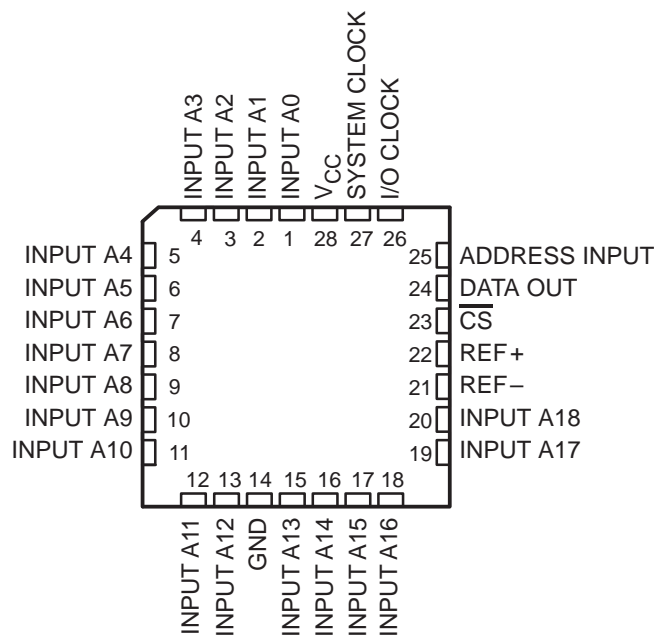

Please be aware that an important notice concerning availability, standard warranty, and use in critical applications of Texas Instruments semiconductor products and disclaimers thereto appears at the end of this data sheet.

PRODUCTION DATA information is current as of publication date. Products conform to specifications per the terms of Texas Instruments standard warranty. Production processing does not necessarily include testing of all parameters.

 **TEXAS
INSTRUMENTS**

POST OFFICE BOX 655303 • DALLAS, TEXAS 75265

Copyright © 1996, Texas Instruments Incorporated

TLC545C, TLC545I, TLC546C, TLC546I 8-BIT ANALOG-TO-DIGITAL CONVERTERS WITH SERIAL CONTROL AND 19 INPUTS

SLAS066B – DECEMBER 1985 – REVISED OCTOBER 1996

AVAILABLE OPTIONS

T _A	PACKAGE	
	CHIP CARRIER (FN)	PLASTIC DIP (N)
0°C to 70°C	TLC545CFN —	TLC545CN —
–40°C to 85°C	TLC545IFN TLC546IFN	TLC545IN TLC546IN

description (continued)

The TLC545C and the TLC546C are characterized for operation from 0°C to 70°C. The TLC545I and the TLC546I are characterized for operation from –40°C to 85°C.

functional block diagram

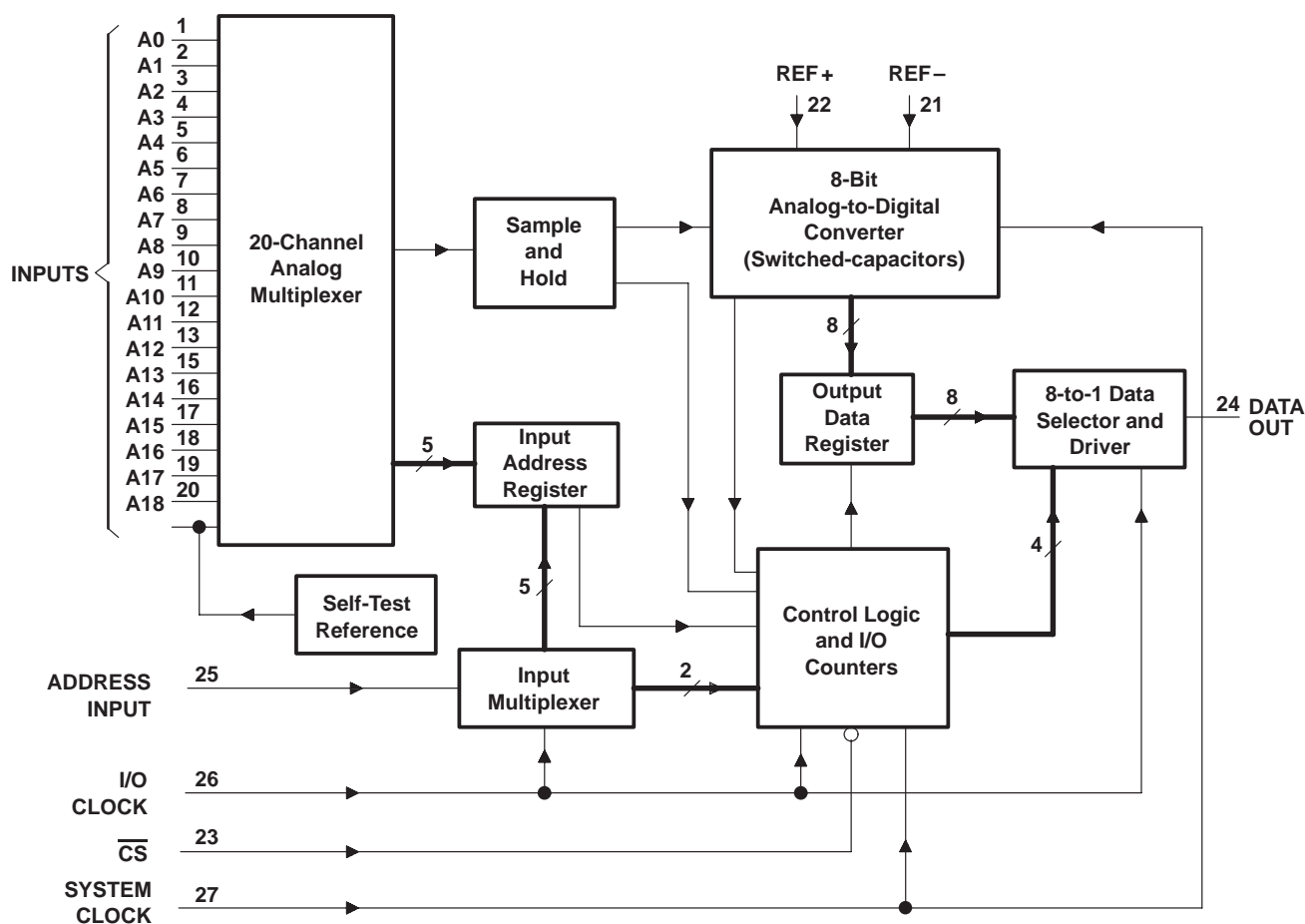

TLC545C, TLC545I, TLC546C, TLC546I 8-BIT ANALOG-TO-DIGITAL CONVERTERS WITH SERIAL CONTROL AND 19 INPUTS

SLAS066B – DECEMBER 1985 – REVISED OCTOBER 1996

typical equivalent inputs

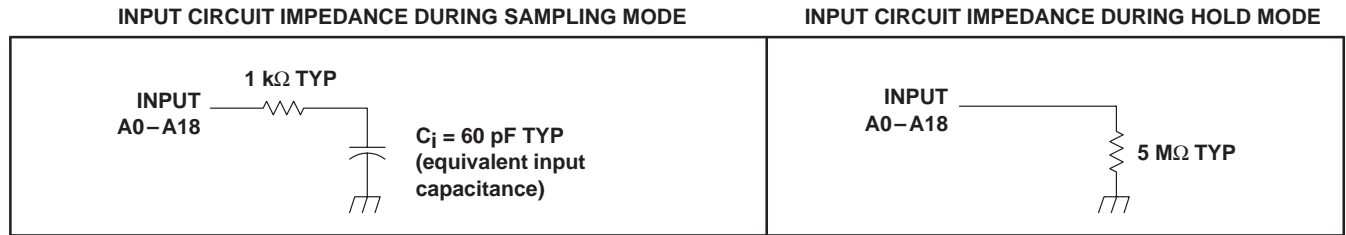

operating sequence

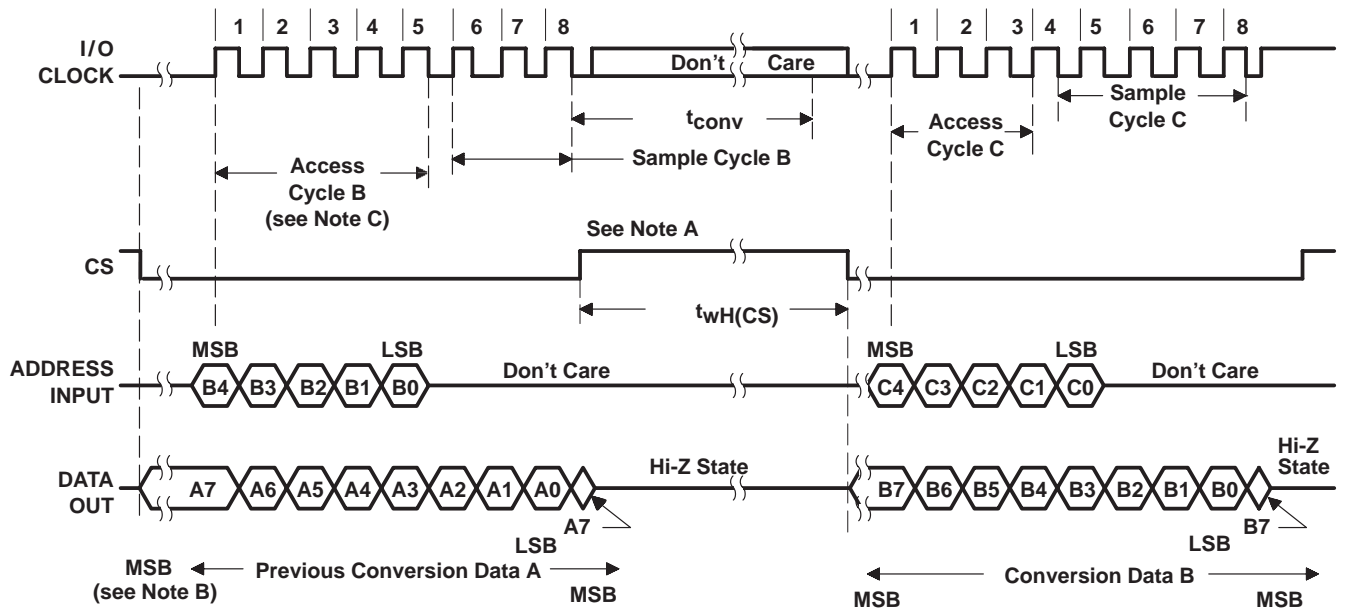

- NOTES:
- The conversion cycle, which requires 36 system clock periods, is initiated with the eighth I/O CLOCK \downarrow after $\overline{CS}\downarrow$ for the channel whose address exists in memory at that time.
 - The most significant bit (MSB) will automatically be placed on the DATA OUT bus after \overline{CS} is brought low. The remaining seven bits (A6–A0) will be clocked out on the first seven I/O CLOCK falling edges.
 - To minimize errors caused by noise at the \overline{CS} input, the internal circuitry waits for three system clock cycles (or less) after a chip select transition before responding to control input signals. Therefore, no attempt should be made to clock-in address data until the minimum chip-select setup time has elapsed.

TLC545C, TLC545I, TLC546C, TLC546I
8-BIT ANALOG-TO-DIGITAL CONVERTERS
WITH SERIAL CONTROL AND 19 INPUTS

SLAS066B – DECEMBER 1985 – REVISED OCTOBER 1996

absolute maximum ratings over operating free-air temperature range (unless otherwise noted)†

Supply voltage, V_{CC} (see Note 1)	6.5 V
Input voltage range, V_I (any input)	-0.3 V to $V_{CC} + 0.3$ V
Output voltage range, V_O	-0.3 V to $V_{CC} + 0.3$ V
Peak input current range (any input)	± 10 mA
Peak total input current (all inputs)	± 30 mA
Operating free-air temperature range, T_A : TLC545C, TLC546C	0°C to 70°C
TLC545I, TLC546I	-40°C to 85°C
Storage temperature range, T_{stg}	-65°C to 150°C
Case temperature for 10 seconds, T_C : FN package	260°C
Lead temperature 1,6 mm (1/16 inch) from case for 10 seconds: N package	260°C

† Stresses beyond those listed under “absolute maximum ratings” may cause permanent damage to the device. These are stress ratings only, and functional operation of the device at these or any other conditions beyond those indicated under “recommended operating conditions” is not implied. Exposure to absolute-maximum-rated conditions for extended periods may affect device reliability.

NOTE 1: All voltage values are with respect to network ground terminal.



TLC545C, TLC545I, TLC546C, TLC546I

8-BIT ANALOG-TO-DIGITAL CONVERTERS

WITH SERIAL CONTROL AND 19 INPUTS

SLAS066B – DECEMBER 1985 – REVISED OCTOBER 1996

recommended operating conditions

	TLC545			TLC546			UNIT
	MIN	NOM	MAX	MIN	NOM	MAX	
Supply voltage, V_{CC}	4.75	5	5.5	4.75	5	5.5	V
Positive reference voltage, V_{ref+} (see Note 2)	0	V_{CC}	$V_{CC} + 0.1$	0	V_{CC}	$V_{CC} + 0.1$	V
Negative reference voltage, V_{ref-} (see Note 3)	-0.1	0	V_{CC}	-0.1	0	V_{CC}	V
Differential reference voltage, $V_{ref+} - V_{ref-}$ (see Note 3)	0	V_{CC}	$V_{CC} + 0.2$	0	V_{CC}	$V_{CC} + 0.2$	V
Analog input voltage (see Note 3)	0		V_{CC}	0		V_{CC}	V
High-level control input voltage, V_{IH}	2			2			V
Low-level control input voltage, V_{IL}			0.8			0.8	V
Setup time, address bits at data input before I/O CLOCK \uparrow , $t_{su(A)}$	200			400			ns
Address hold time, t_h	0			0			ns
Setup time, \overline{CS} low before clocking in first address bit, $t_{su(CS)}$ (see Note 2)	3			3			System clock cycles
I/O CLOCK frequency, $f_{clock(I/O)}$	0		2.048	0		1.1	MHz
SYSTEM CLOCK frequency, $f_{clock(SYS)}$	$f_{clock(I/O)}$		4	$f_{clock(I/O)}$		2.1	MHz
Pulse duration, \overline{CS} high during conversion, $t_{wH(CS)}$	36			36			System clock cycles
Pulse duration, SYSTEM CLOCK high, $t_{wH(SYS)}$	110			210			ns
Pulse duration, SYSTEM CLOCK low, $t_{wL(SYS)}$	100			190			ns
Pulse duration, I/O CLOCK high, $t_{wH(I/O)}$	200			404			ns
Pulse duration, I/O CLOCK low, $t_{wL(I/O)}$	200			404			ns
Clock transition time (see Note 4)	System	$f_{clock(SYS)} \leq 1048$ kHz	30		30		ns
		$f_{clock(SYS)} > 1048$ kHz	20		20		
	I/O	$f_{clock(I/O)} \leq 525$ kHz	100		100		ns
		$f_{clock(I/O)} > 525$ kHz	40		40		
Operating free-air temperature, T_A	TLC545C, TLC546C	0	70	0	70		°C
	TLC545I, TLC546I	-40	85	-40	85		

- NOTES:
- To minimize errors caused by noise at \overline{CS} , the internal circuitry waits for three system clock cycles (or less) after a chip select falling edge or rising edge is detected before responding to control input signals. Therefore, no attempt should be made to clock-in address data until the minimum chip select setup time has elapsed.
 - Analog input voltages greater than that applied to REF+ convert as all "1"s (11111111), while input voltages less than that applied to REF- convert as all "0"s (00000000). As the differential reference voltage decreases below 4.75 V, the total unadjusted error tends to increase.
 - This is the time required for the clock input signal to fall from V_{IH} min to V_{IL} max or to rise from V_{IL} max to V_{IH} min. In the vicinity of normal room temperature, the devices function with input clock transition time as slow as 2 μ s for remote data acquisition applications where the sensor and the A/D converter are placed several feet away from the controlling microprocessor.



TLC545C, TLC545I, TLC546C, TLC546I
8-BIT ANALOG-TO-DIGITAL CONVERTERS
WITH SERIAL CONTROL AND 19 INPUTS

SLAS066B – DECEMBER 1985 – REVISED OCTOBER 1996

electrical characteristics over recommended operating temperature range,
 $V_{CC} = V_{ref+} = 4.75\text{ V to }5.5\text{ V}$, $f_{clock(I/O)} = 2.048\text{ MHz}$ for TLC545 or $f_{clock(I/O)} = 1.1\text{ MHz}$ for TLC546
(unless otherwise noted)

PARAMETER		TEST CONDITIONS	MIN	TYP†	MAX	UNIT
V_{OH}	High-level output voltage (DATA OUT)	$V_{CC} = 4.75\text{ V}$, $I_{OH} = -360\text{ }\mu\text{A}$	2.4			V
V_{OL}	Low-level output voltage	$V_{CC} = 4.75\text{ V}$, $I_{OL} = 3.2\text{ mA}$			0.4	V
I_{OZ}	Off-state (high-impedance state) output current	$V_O = V_{CC}$, \overline{CS} at V_{CC}			10	μA
		$V_O = 0$, \overline{CS} at V_{CC}			-10	
I_{IH}	High-level input current	$V_I = V_{CC}$		0.005	2.5	μA
I_{IL}	Low-level input current	$V_I = 0$		-0.005	-2.5	μA
I_{CC}	Operating supply current	\overline{CS} at 0 V		1.2	2.5	mA
	Selected channel leakage current	Selected channel at V_{CC} , Unselected channel at 0 V		0.4	1	μA
		Selected channel at 0 V, Unselected channel at V_{CC}		-0.4	-1	
$I_{CC} + I_{ref}$	Supply and reference current	$V_{ref+} = V_{CC}$, \overline{CS} at 0 V		1.3	3	mA
C_i	Input capacitance	Analog inputs		7	55	pF
		Control inputs		5	15	

† All typical values are at $T_A = 25^\circ\text{C}$.



TLC545C, TLC545I, TLC546C, TLC546I
8-BIT ANALOG-TO-DIGITAL CONVERTERS
WITH SERIAL CONTROL AND 19 INPUTS

SLAS066B – DECEMBER 1985 – REVISED OCTOBER 1996

operating characteristics over recommended operating free-air temperature range,
 $V_{CC} = V_{ref+} = 4.75\text{ V to }5.5\text{ V}$, $f_{clock(I/O)} = 2.048\text{ MHz for TLC545 or }1.1\text{ MHz for TLC546}$,
 $f_{clock(SYS)} = 4\text{ MHz for TLC545 or }2.1\text{ MHz for TLC546}$

PARAMETER	TEST CONDITIONS	TLC545			TLC546			UNIT
		MIN	TYP	MAX	MIN	TYP	MAX	
E_L Linearity error	See Note 5			±0.5			±0.5	LSB
E_{ZS} Zero-scale error	See Note 6			±0.5			±0.5	LSB
E_{FS} Full-scale error	See Note 6			±0.5			±0.5	LSB
Total unadjusted error	See Note 7			±0.5			±0.5	LSB
Self-test output code	INPUT A19 address = 10011 (see Note 8)	01111101 (125)		10000011 (131)	01111101 (125)		10000011 (131)	
t_{conv} Conversion time	See Operating Sequence			9			17	μs
Total access and conversion time	See Operating Sequence			13			25	μs
t_{acq} Channel acquisition time (sample cycle)	See Operating Sequence			3			3	I/O clock cycles
t_v Time output data remains valid after I/O CLOCK↓		10			10			ns
t_d Delay time, I/O CLOCK to DATA OUT valid	See Parameter Measurement Information			300			400	ns
t_{en} Output enable time				150			150	ns
t_{dis} Output disable time				150			150	ns
$t_{r(bus)}$ Data bus rise time				300			300	ns
$t_{f(bus)}$ Data bus fall time				300			300	ns

- NOTES: 5. Linearity error is the maximum deviation from the best straight line through the A/D transfer characteristics.
6. Zero-scale error is the difference between 00000000 and the converted output for zero input voltage; full-scale error is the difference between 11111111 and the converted output for full-scale input voltage.
7. Total unadjusted error is the sum of linearity, zero-scale, and full-scale errors.
8. Both the input address and the output codes are expressed in positive logic. The INPUT A19 analog input signal is internally generated and is used for test purposes.



TLC545C, TLC545I, TLC546C, TLC546I
 8-BIT ANALOG-TO-DIGITAL CONVERTERS
 WITH SERIAL CONTROL AND 19 INPUTS

SLAS066B – DECEMBER 1985 – REVISED OCTOBER 1996

PARAMETER MEASUREMENT INFORMATION

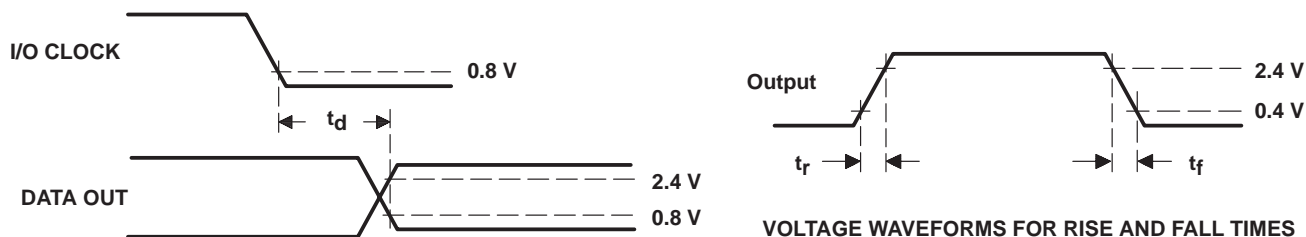
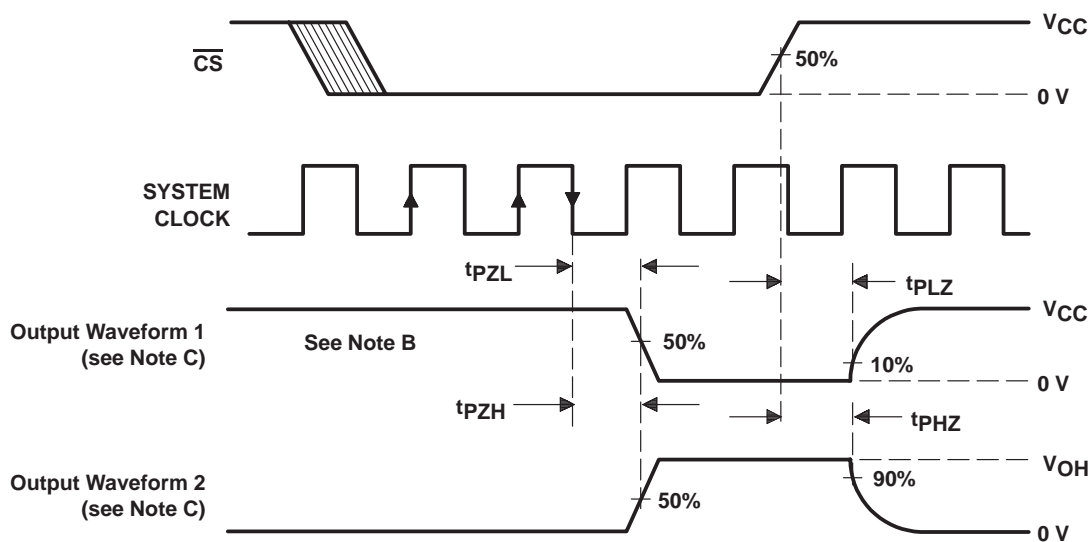
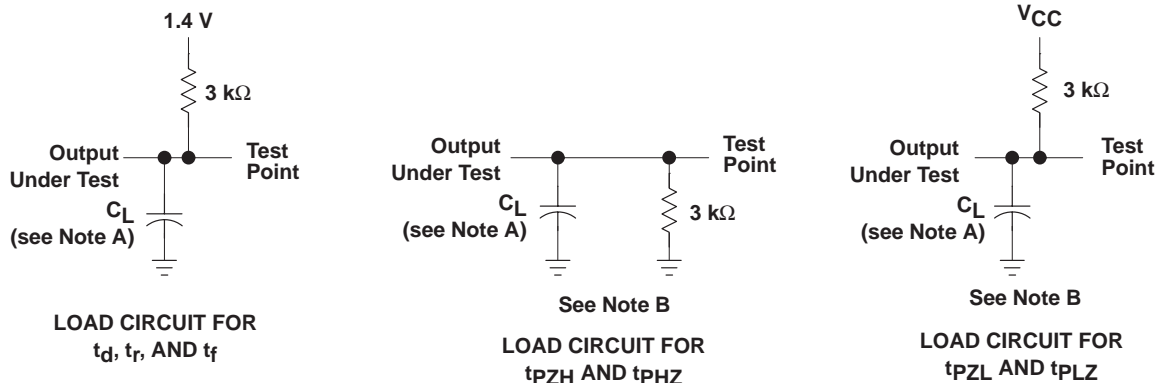

VOLTAGE WAVEFORMS FOR DELAY TIME

- NOTES: A. $C_L = 50$ pF for TLC545 and 100 pF for TLC546
 B. $t_{en} = t_{PZH}$ or t_{PZL} , $t_{dis} = t_{PHZ}$ or t_{PLZ}
 C. Waveform 1 is for an output with internal conditions such that the output is low except when disabled by the output control.
 Waveform 2 is for an output with internal conditions such that the output is high except when disabled by the output control.

PARAMETER MEASUREMENT INFORMATION

simplified analog input analysis

Using the equivalent circuit in Figure 1, the time required to charge the analog input capacitance from 0 to V_S within 1/2 LSB can be derived as follows:

The capacitance charging voltage is given by

$$V_C = V_S \left(1 - e^{-t_c / R_t C_i}\right) \quad (1)$$

where

$$R_t = R_s + r_i$$

The final voltage to 1/2 LSB is given by

$$V_C (1/2 \text{ LSB}) = V_S - (V_S/512) \quad (2)$$

Equating equation 1 to equation 2 and solving for time t_c gives

$$V_S - (V_S/512) = V_S \left(1 - e^{-t_c / R_t C_i}\right) \quad (3)$$

and

$$t_c (1/2 \text{ LSB}) = R_t \times C_i \times \ln(512) \quad (4)$$

Therefore, with the values given the time for the analog input signal to settle is

$$t_c (1/2 \text{ LSB}) = (R_s + 1 \text{ k}\Omega) \times 60 \text{ pF} \times \ln(512) \quad (5)$$

This time must be less than the converter sample time shown in the timing diagrams.

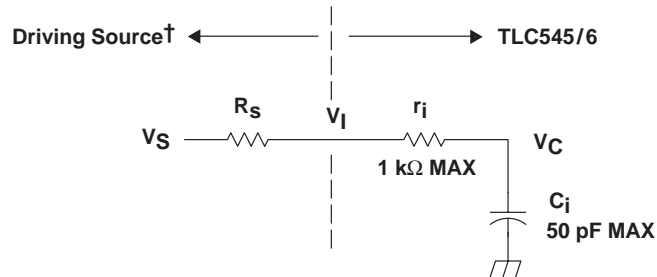

V_I = Input Voltage at INPUT A0–A18
 V_S = External Driving Source Voltage
 R_S = Source Resistance
 r_i = Input Resistance
 C_i = Input Capacitance

† Driving source requirements:

- Noise and distortion for the source must be equivalent to the resolution of the converter.
- R_S must be real at the input frequency.

Figure 1. Equivalent Input Circuit Including the Driving Source

TLC545C, TLC545I, TLC546C, TLC546I

8-BIT ANALOG-TO-DIGITAL CONVERTERS

WITH SERIAL CONTROL AND 19 INPUTS

SLAS066B – DECEMBER 1985 – REVISED OCTOBER 1996

PRINCIPLES OF OPERATION

The TLC545 and TLC546 are both complete data acquisition systems on single chips. Each includes such functions as system clock, sample and hold, 8-bit A/D converter, data and control registers, and control logic. For flexibility and access speed, there are four control inputs; \overline{CS} , ADDRESS INPUT, I/O CLOCK, and SYSTEM CLOCK. These control inputs and a TTL-compatible 3-state output facilitate serial communications with a microprocessor or microcomputer. The TLC545 and TLC546 can complete conversions in a maximum of 9 and 17 μ s respectively, while complete input-conversion-output cycles can be repeated at a maximum of 13 and 25 μ s, respectively.

The system clock and I/O clock are normally used independently and do not require any special speed or phase relationships between them. This independence simplifies the hardware and software control tasks for the device. Once a clock signal within the specification range is applied to the SYSTEM CLOCK input, the control hardware and software need only be concerned with addressing the desired analog channel, reading the previous conversion result, and starting the conversion by using the I/O CLOCK. SYSTEM CLOCK will drive the “conversion crunching” circuitry so that the control hardware and software need not be concerned with this task.

When \overline{CS} is high, DATA OUT is in a high-impedance condition, and ADDRESS INPUT and I/O CLOCK are disabled. This feature allows each of these terminals, with the exception of \overline{CS} , to share a control logic point with their counterpart terminals on additional A/D devices when additional TLC545/TLC546 devices are used. Thus, the above feature serves to minimize the required control logic terminals when using multiple A/D devices.

The control sequence has been designed to minimize the time and effort required to initiate conversion and obtain the conversion result. A normal control sequence is:

1. \overline{CS} is brought low. To minimize errors caused by noise at \overline{CS} , the internal circuitry waits for two rising edges and then a falling edge of the SYSTEM CLOCK after a \overline{CS} transition before the transition is recognized. The MSB of the previous conversion result automatically appears on DATA OUT.
2. A new positive-logic multiplexer address is shifted in on the first five rising edges of I/O CLOCK. The MSB of the address is shifted in first. The negative edges of these five I/O clocks shift out the second, third, fourth, fifth, and sixth most significant bits of the previous conversion result. The on-chip sample and hold begins sampling the newly addressed analog input after the fifth falling edge. The sampling operation basically involves the charging of internal capacitors to the level of the analog input voltage.
3. Two clock cycles are then applied to I/O CLOCK and the seventh and eighth conversion bits are shifted out on the negative edges of these clock cycles.
4. The final eighth clock cycle is applied to I/O CLOCK. The falling edge of this clock cycle completes the analog sampling process and initiates the hold function. Conversion is then performed during the next 36 system clock cycles. After this final I/O clock cycle, \overline{CS} must go high or the I/O CLOCK must remain low for at least 36 system clock cycles to allow for the conversion function.

\overline{CS} can be kept low during periods of multiple conversion. When keeping \overline{CS} low during periods of multiple conversion, special care must be exercised to prevent noise glitches on the I/O CLOCK line. If glitches occur on the I/O CLOCK line, the I/O sequence between the microprocessor/controller and the device loses synchronization. Also, if \overline{CS} is taken high, it must remain high until the end of conversion. Otherwise, a valid falling edge of \overline{CS} causes a reset condition, which aborts the conversion in progress.

A new conversion may be started and the ongoing conversion simultaneously aborted by performing steps 1 through 4 before the 36 system clock cycles occur. Such action yields the conversion result of the previous conversion and not the ongoing conversion.



POST OFFICE BOX 655303 • DALLAS, TEXAS 75265

PRINCIPLES OF OPERATION

It is possible to connect SYSTEM CLOCK and I/O CLOCK together in special situations in which controlling circuitry points must be minimized. In this case, the following special points must be considered in addition to the requirements of the normal control sequence previously described.

1. The first two clocks are required for this device to recognize \overline{CS} is at a valid low level when the common clock signal is used as an I/O CLOCK. When \overline{CS} is recognized by the device to be at a high level, the common clock signal is used for the conversion clock also.
2. A low \overline{CS} must be recognized before the I/O CLOCK can shift in an analog channel address. The device recognizes a \overline{CS} transition when the SYSTEM CLOCK terminal receives two positive edges and then a negative edge. For this reason, after a \overline{CS} negative edge, the first two clock cycles do not shift in the address. Also, upon shifting in the address, \overline{CS} must be raised after the eighth valid (10 total) I/O CLOCK. Otherwise, additional common clock cycles are recognized as I/O CLOCKS and shift in an erroneous address.

For certain applications, such as strobing applications, it is necessary to start conversion at a specific point in time. This device accommodates these applications. Although the on-chip sample and hold begins sampling upon the negative edge of the fourth valid I/O clock cycle, the hold function is not initiated until the negative edge of the eighth valid I/O clock cycle. Thus, the control circuitry can leave the I/O clock signal in its high state during the eighth valid I/O clock cycle, until the moment at which the analog signal must be converted. The TLC545/546 continues sampling the analog input until the eighth valid falling edge of the I/O clock. The control circuitry or software must then immediately lower the I/O clock signal to initiate the hold function at the desired point in time and to start conversion.

IMPORTANT NOTICE

Texas Instruments and its subsidiaries (TI) reserve the right to make changes to their products or to discontinue any product or service without notice, and advise customers to obtain the latest version of relevant information to verify, before placing orders, that information being relied on is current and complete. All products are sold subject to the terms and conditions of sale supplied at the time of order acknowledgement, including those pertaining to warranty, patent infringement, and limitation of liability.

TI warrants performance of its semiconductor products to the specifications applicable at the time of sale in accordance with TI's standard warranty. Testing and other quality control techniques are utilized to the extent TI deems necessary to support this warranty. Specific testing of all parameters of each device is not necessarily performed, except those mandated by government requirements.

CERTAIN APPLICATIONS USING SEMICONDUCTOR PRODUCTS MAY INVOLVE POTENTIAL RISKS OF DEATH, PERSONAL INJURY, OR SEVERE PROPERTY OR ENVIRONMENTAL DAMAGE ("CRITICAL APPLICATIONS"). TI SEMICONDUCTOR PRODUCTS ARE NOT DESIGNED, AUTHORIZED, OR WARRANTED TO BE SUITABLE FOR USE IN LIFE-SUPPORT DEVICES OR SYSTEMS OR OTHER CRITICAL APPLICATIONS. INCLUSION OF TI PRODUCTS IN SUCH APPLICATIONS IS UNDERSTOOD TO BE FULLY AT THE CUSTOMER'S RISK.

In order to minimize risks associated with the customer's applications, adequate design and operating safeguards must be provided by the customer to minimize inherent or procedural hazards.

TI assumes no liability for applications assistance or customer product design. TI does not warrant or represent that any license, either express or implied, is granted under any patent right, copyright, mask work right, or other intellectual property right of TI covering or relating to any combination, machine, or process in which such semiconductor products or services might be or are used. TI's publication of information regarding any third party's products or services does not constitute TI's approval, warranty or endorsement thereof.

Looking for pricing, stock, or lifecycle information?

Click below to explore more details on WIN SOURCE:

 [View TLC545IFN on WIN SOURCE](#)

 [Texas Instruments](#) Information

Optimize Your Supply Chain with WIN SOURCE Solutions

-  Global Sourcing Solution
-  Obsolete Management
-  Cost Control Management
-  Shortage Management
-  Alternative Solution
-  Excess Inventory Management