



THE DATASHEET OF CY7B995AXI





CY7B995 RoboClock®

2.5/3.3 V 200 MHz High-Speed Multi-Phase PLL Clock Buffer

Features

- 2.5 V or 3.3 V operation
- Split output bank power supplies
- Output frequency range: 6 MHz to 200 MHz
- 45 ps typical cycle-cycle jitter
- $\pm 2\%$ max output duty cycle
- Selectable output drive strength
- Selectable positive or negative edge synchronization
- Eight LVTTTL outputs driving $50\ \Omega$ terminated lines
- LVCMOS/LVTTTL over-voltage tolerant reference input
- Selectable phase-locked loop (PLL) frequency range and lock indicator
- Phase adjustments in 625/1250 ps steps up to ± 7.5 ns
- (1-6, 8, 10, 12) x multiply and (1/2, 1/4) x divide ratios
- Spread-Spectrum compatible
- Power down mode
- Selectable reference divider
- Industrial temperature range: $-40\ ^\circ\text{C}$ to $+85\ ^\circ\text{C}$
- 44-pin TQFP package

Functional Description

The CY7B995 RoboClock® is a low voltage, low power, eight-output, 200 MHz clock driver. It features output phase programmability which is necessary to optimize the timing of high performance computer and communication systems.

The user can program both the frequency and the phase of the output banks through nF[0:1] and DS[0:1] pins. The adjustable phase feature allows the user to skew the outputs to lead or lag the reference clock. Any one of the outputs can be connected to feedback to achieve different reference frequency multiplication, and divide ratios and zero input-output delay.

The device also features split output bank power supplies, which enable the user to run two banks (1Qn and 2Qn) at a power supply level, different from that of the other two banks (3Qn and 4Qn). The three-level PE/HD pin also controls the synchronization of the output signals to either the rising, or the falling edge of the reference clock and selects the drive strength of the output buffers. The high drive option (PE/HD = MID) increases the output current from ± 12 mA to ± 24 mA.

For a complete list of related documentation, [click here](#).

Logic Block Diagram

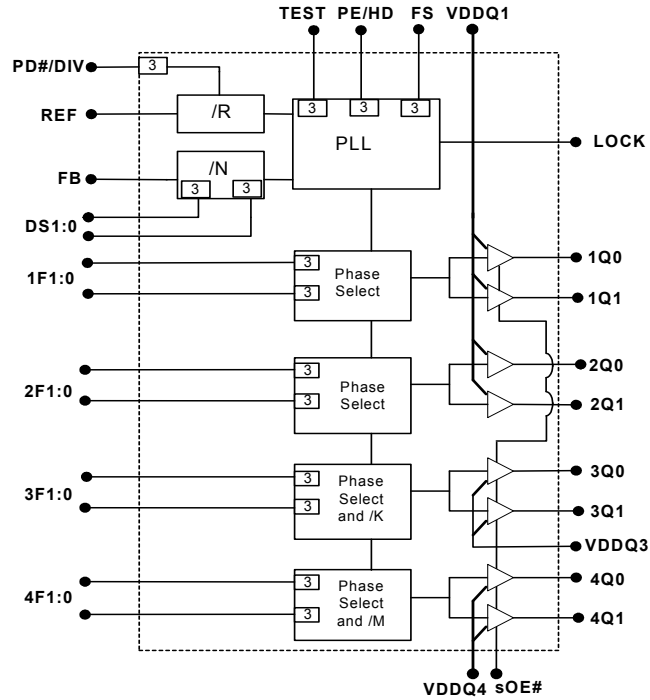

Contents

Pinouts	4	Package Drawing and Dimension	16
Pin Definitions	5	Acronyms	17
Device Configuration	6	Document Conventions	17
Governing Agencies	7	Units of Measure	17
Absolute Maximum Conditions	8	Document History Page	18
DC Specifications at 2.5 V	9	Sales, Solutions, and Legal Information	19
DC Specifications at 3.3 V	10	Worldwide Sales and Design Support	19
Thermal Resistance	11	Products	19
AC Test Loads and Waveforms	11	PSoC@Solutions	19
AC Input Specifications	12	Cypress Developer Community	19
Switching Characteristics	13	Technical Support	19
AC Timing Definitions	14		
Ordering Information	15		
Ordering Code Definitions	15		

Pinouts

Figure 1. 44-pin TQFP pinout (Top View)

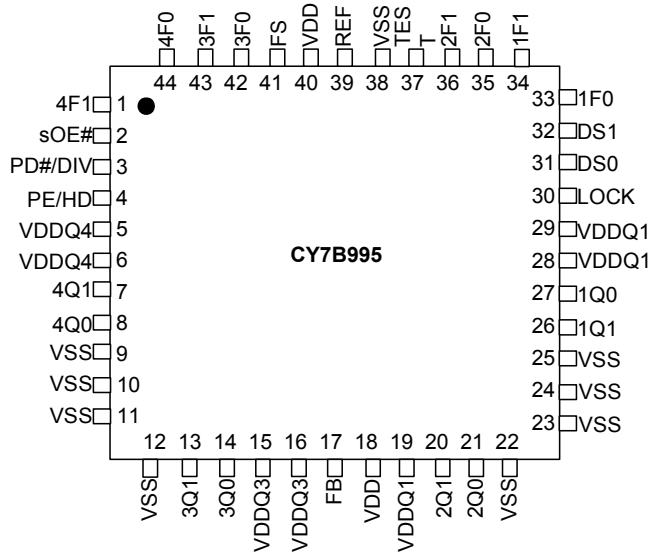

Pin Definitions

44-pin TQFP Package

Pin	Name	I/O ^[1]	Type	Description
39	REF	I	LVTTL/LVCMOS	Reference Clock Input.
17	FB	I	LVTTL	Feedback Input.
37	TEST	I	3-Level	When MID or HIGH, disables PLL^[2]. REF goes to all outputs. Set LOW for normal operation.
2	sOE#	I, PD	LVTTL	Synchronous Output Enable. When HIGH, it stops clock outputs (except 2Q0 and 2Q1) in a LOW state (for PE/HD = H or M) – 2Q0, and 2Q1 may be used as the feedback signal to maintain phase lock. When TEST is held at MID level and sOE# is HIGH, the nF[1:0] pins act as output disable controls for individual banks when nF[1:0] = LL. Set sOE# LOW for normal operation.
4	PE/HD	I, PU	3-Level	Selects Positive or Negative Edge Control, and High or Low output Drive Strength. When LOW/HIGH, the outputs are synchronized with the negative/positive edge of the reference clock respectively. When at MID level, the output drive strength is increased and the outputs synchronize with the positive edge of the reference clock. See Table 9 on page 7 .
34, 33, 36, 35, 43, 42, 1, 44	nF[1:0]	I	3-Level	Selects Frequency and Phase of the Outputs. See Table 3 , Table 4 , Table 5 , Table 7 , and Table 8 on page 7 .
41	FS	I	3-Level	Selects VCO Operating Frequency Range. See Table 6 on page 7 .
26, 27, 20, 21, 13, 14, 7, 8	nQ[1:0]	O	LVTTL	Four banks of two outputs. See Table 5 on page 6 for frequency settings.
32, 31	DS[1:0]	I	3-Level	Selects Feedback Divider. See Table 2 on page 6 .
3	PD#/DIV	I, PU	3-Level	Power down and Reference Divider Control. When LOW, shuts off entire chip. When at MID level, enables the reference divider. See Table 1 on page 6 for settings.
30	LOCK	O	LVTTL	PLL Lock Indication Signal. HIGH indicates lock, LOW indicates the PLL is not locked, and outputs may not be synchronized to the input.
5,6	V _{DD} Q4 ^[3]	PWR	Power	Power supply for Bank 4 Output Buffers. See Table 10 on page 7 for supply level constraints.
15,16	V _{DD} Q3 ^[3]	PWR	Power	Power supply for Bank 3 Output Buffers. See Table 10 on page 7 for supply level constraints.
19,28,29	V _{DD} Q1 ^[3]	PWR	Power	Power supply for Bank 1 and Bank 2 Output Buffers. See Table 10 on page 7 for supply level constraints.
18,40	V _{DD} ^[3]	PWR	Power	Power supply for the Internal Circuitry. See Table 10 on page 7 for supply level constraints.
9–12, 22–25, 38	V _{SS}	PWR	Power	Ground

Notes

1. PD indicates an internal pull down and 'PU' indicates an internal pull up.
2. When TEST = MID and sOE# = HIGH, PLL remains active with nF[1:0] = LL functioning as an output disable control for individual output banks. Skew selections remain in effect unless nF[1:0] = LL.
3. A bypass capacitor (0.1µF) must be placed as close as possible to each positive power pin (< 0.2"). If these bypass capacitors are not close to the pins, their high frequency filtering characteristic is cancelled by the lead inductance of the traces.

Device Configuration

The outputs of the CY7B995 can be configured to run at frequencies ranging from 6 MHz to 200 MHz. The feedback input divider is controlled by the 3-level DS[0:1] pins as indicated in Table 2, and the reference input divider is controlled by the 3-level PD#/DIV pin as indicated in Table 1.

Table 1. Reference Divider Settings

PD#/DIV	R-Reference Divider
H	1
M	2
L ^[4]	N/A

Table 2. Feedback Divider Settings

DS[1:0]	N-Feedback Input Divider	Permitted Output Divider Connected to FB
LL	2	1 or 2
LM	3	1
LH	4	1, 2 or 4
ML	5	1 or 2
MM	1	1, 2 or 4
MH	6	1 or 2
HL	8	1 or 2
HM	10	1
HH	12	1

In addition to the reference and feedback dividers, the CY7B995 includes output dividers on Bank3 and Bank4, which are

controlled by 3F[1:0] and 4F[1:0] as indicated in Table 3 and Table 4, respectively.

Table 3. Output Divider Settings – Bank 3

3F[1:0]	K - Bank3 Output Divider
LL	2
HH	4
Other ^[5]	1

Table 4. Output Divider Settings – Bank 4

4F[1:0]	M- Bank4 Output Divider
LL	2
Other ^[5]	1

The divider settings and the FB input to any output connection needed to produce various output frequencies are summarized in Table 5.

Table 5. Output Frequency Settings

Configuration	Output Frequency		
	FB Input Connected to	1Q[0:1] and 2Q[0:1] ^[6]	3Q[0:1]
1Qn or 2Qn	(N / R) x F _{REF}	(N / R) x (1 / K) x F _{REF}	(N / R) x (1 / M) x F _{REF}
3Qn	(N / R) x K x F _{REF}	(N / R) x F _{REF}	(N / R) x (K / M) x F _{REF}
4Qn	(N / R) x M x F _{REF}	(N / R) x (M / K) x F _{REF}	(N / R) x F _{REF}

Notes

- When PD#/DIV = LOW, the device enters power down mode.
- These states are used to program the phase of the respective banks. See Table 7 and Table 8.
- These outputs are undivided copies of the VCO clock. The formulas in this column can be used to calculate the VCO operating frequency (FNOM) at a given reference frequency (FREF), and divider and feedback configuration. The user must select a configuration and a reference frequency that generates a VCO frequency, and is within the range specified by FS pin. See Table 6.

The 3-level FS control pin setting determines the nominal operating frequency range of the divide-by-one outputs of the device. The CY7B995 PLL operating frequency range that corresponds to each FS level is given in [Table 6](#).

Table 6. Frequency Range Select

FS	PLL Frequency Range
L	24 to 50 MHz
M	48 to 100 MHz
H	96 to 200 MHz

Selectable output skew is in discrete increments of time units (t_U). The value of t_U is determined by the FS setting and the maximum nominal frequency. The equation used to determine the t_U value is: $t_U = 1 / (f_{NOM} \times MF)$

where MF is a multiplication factor which is determined by the FS setting as indicated in [Table 7](#).

Table 7. MF Calculation

FS	MF	f_{NOM} at which t_U is 1.0 ns (MHz)
L	32	31.25
M	16	62.5
H	8	125

Table 8. Output Skew Settings

nF[1:0]	Skew (1Q[0:1], 2Q[0:1])	Skew (3Q[0:1])	Skew (4Q[0:1])
LL ^[7]	$-4t_U$	Divide By 2	Divide By 2
LM	$-3t_U$	$-6t_U$	$-6t_U$
LH	$-2t_U$	$-4t_U$	$-4t_U$
ML	$-1t_U$	$-2t_U$	$-2t_U$
MM	Zero Skew	Zero Skew	Zero Skew
MH	$+1t_U$	$+2t_U$	$+2t_U$
HL	$+2t_U$	$+4t_U$	$+4t_U$
HM	$+3t_U$	$+6t_U$	$+6t_U$
HH	$+4t_U$	Divide By 4	Inverted ^[8]

In addition to determining whether the outputs synchronize to the rising or the falling edge of the reference signal, the 3-level PE/HD pin controls the output buffer drive strength as indicated in [Table 9](#). Refer to the AC Timing Definitions section for a description of input-to-output and output-to-output phase relationships.

Table 9. PE/HD Settings

PE/HD	Synchronization	Output Drive Strength ^[9]
L	Negative	Low Drive
M	Positive	High Drive
H	Positive	Low Drive

The CY7B995 features split power supply buses for Banks 1 and 2, Bank 3 and Bank 4, which enables the user to obtain both 3.3 V and 2.5 V output signals from one device. The core power supply (V_{DD}) must be set at a level that is equal to or higher than any of the output power supplies.

Table 10. Power Supply Constraints

V_{DD}	V_{DDQ1} ^[10]	V_{DDQ3} ^[10]	V_{DDQ4} ^[10]
3.3 V	3.3 V or 2.5 V	3.3 V or 2.5 V	3.3 V or 2.5 V
2.5 V	2.5 V	2.5 V	2.5 V

Governing Agencies

The following agencies provide specifications that apply to the CY7B995. The agency name and relevant specification is listed below.

Table 11. Governing Agencies and Specifications

Agency Name	Specification
JEDEC	JESD 51 (Theta JA)
	JESD 65 (Skew, Jitter)
IEEE	1596.3 (Jitter Specs)
UL-194_V0	94 (Moisture Grading)
MIL	883E Method 1012.1 (Therma Theta JC)

Notes

- LL disables outputs if TEST = MID and SOE# = HIGH.
- When 4Q[0:1] are set to run inverted (HH mode), SOE# disables these outputs HIGH when PE/HD = HIGH or MID, SOE# disables them LOW when PE/HD = LOW.
- Please refer to "DC Parameters" section for I_{OH}/I_{OL} specifications.
- $V_{DDQ1/3/4}$ must not be set at a level higher than that of V_{DD} . They can be set at different levels from each other, e.g., $V_{DD} = 3.3$ V, $V_{DDQ1} = 3.3$ V, $V_{DDQ3} = 2.5$ V and $V_{DDQ4} = 2.5$ V.

Absolute Maximum Conditions

Parameter	Description	Condition	Min	Max	Unit
V _{DD}	Operating Voltage	Functional @ 2.5 V ± 5%	2.25	2.75	V
V _{DD}	Operating Voltage	Functional @ 3.3 V ± 10%	2.97	3.63	V
V _{IN(MIN)}	Input Voltage	Relative to V _{SS}	V _{SS} - 0.3	-	V
V _{IN(MAX)}	Input Voltage	Relative to V _{DD}	-	V _{DD} + 0.3	V
V _{REF(MAX)}	Reference Input Voltage	V _{DD} = 3.3 V	-	5.5	V
V _{REF(MAX)}	Reference Input Voltage	V _{DD} = 2.5 V	-	4.6	V
T _S	Temperature, Storage	Non Functional	-65	+150	°C
T _A	Temperature, Operating Ambient	Functional	-40	+85	°C
T _J	Temperature, Junction	Functional	-	155	°C
∅ _{JC}	Dissipation, Junction to Case	Mil-Spec 883E Method 1012.1	-	42	°C/W
∅ _{JA}	Dissipation, Junction to Ambient	JEDEC (JESD 51)	-	74	°C/W
ESD _{HBM}	ESD Protection (Human Body Model)	MIL-STD-883, Method 3015	2000	-	V
UL-94	Flammability Rating	@1/8 in.	V-0		
MSL	Moisture Sensitivity Level		1		
F _{IT}	Failure in Time	Manufacturing Testing	10		ppm

DC Specifications at 2.5 V

Parameter	Description	Condition	Min	Max	Unit	
V _{DD}	2.5 V Operating Voltage	2.5 V ± 5%	2.375	2.625	V	
V _{IL}	Input LOW Voltage	REF, FB, and sOE# Inputs	–	0.7	V	
V _{IH}	Input HIGH Voltage		1.7	–	V	
V _{IHH} ^[11]	Input HIGH Voltage	3-Level Inputs, (TEST, FS, nF[1:0], DS[1:0], PD#/DIV, PE/HD). (These pins are normally wired to V _{DD} , GND, or unconnected)	V _{DD} – 0.4	–	V	
V _{IMM} ^[11]	Input MID Voltage		V _{DD} /2 – 0.2	V _{DD} /2 + 0.2	V	
V _{ILL} ^[11]	Input LOW Voltage		–	0.4	V	
I _{IL}	Input Leakage Current	V _{IN} = V _{DD} /G _{ND} , V _{DD} = Max; (REF and FB Inputs)	–5	5	μA	
I ₃	3-Level Input DC Current	HIGH, V _{IN} = V _{DD}	3-Level Inputs (TEST, FS, nF[1:0], DS[1:0], PD#/DIV, PE/HD)	–	200	μA
		MID, V _{IN} = V _{DD} /2		–50	50	μA
		LOW, V _{IN} = V _{SS}		–200	–	μA
I _{PU}	Input Pull-Up Current	V _{IN} = V _{SS} , V _{DD} = Max	–25	–	μA	
I _{PD}	Input Pull-Down Current	V _{IN} = V _{DD} , V _{DD} = Max, (sOE#)	–	100	μA	
V _{OL}	Output LOW Voltage	I _{OL} = 12 mA (PE/HD = L/H), (nQ[0:1])	–	0.4	V	
		I _{OL} = 20 mA (PE/HD = MID), (nQ[0:1])	–	0.4	V	
		I _{OL} = 2 mA (LOCK)	–	0.4	V	
V _{OH}	Output HIGH Voltage	I _{OH} = –12 mA (PE/HD = L/H), (nQ[0:1])	2.0	–	V	
		I _{OH} = –20 mA (PE/HD = MID), (nQ[0:1])	2.0	–	V	
		I _{OH} = –2 mA (LOCK)	2.0	–	V	
I _{DDQ}	Quiescent Supply Current	V _{DD} = Max, TEST = MID, REF = LOW, sOE# = LOW, Outputs Not Loaded	–	2	mA	
I _{DDPD}	Power down Current	PD#/DIV, sOE# = LOW Test, nF[1:0], DS[1:0] = HIGH; V _{DD} = Max	10(typ.)	25	μA	
I _{DD}	Dynamic Supply Current	At 100 MHz	150		mA	
C _{IN}	Input Pin Capacitance		4		pF	

Note

11. These Inputs are normally wired to V_{DD}, GND or unconnected. Internal termination resistors bias unconnected inputs to V_{DD}/2.

DC Specifications at 3.3 V

Parameter	Description	Condition	Min	Max	Unit	
V _{DD}	3.3 V Operating Voltage	3.3 V ± 10%	2.97	3.63	V	
V _{IL}	Input LOW Voltage	REF, FB and sOE# Inputs	–	0.8	V	
V _{IH}	Input HIGH Voltage		2.0	–	V	
V _{IHH} ^[12]	Input HIGH Voltage	3-Level Inputs (TEST, FS, nF[1:0], DS[1:0], PD#/DIV, PE/HD); (These pins are normally wired to VDD, GND or unconnected)	V _{DD} – 0.6	–	V	
V _{IMM} ^[12]	Input MID Voltage		V _{DD} /2 – 0.3	V _{DD} /2 + 0.3	V	
V _{ILL} ^[12]	Input LOW Voltage		–	0.6	V	
I _{IL}	Input Leakage Current	V _{IN} = V _{DD} /G _{ND} , V _{DD} = Max (REF and FB inputs)	–5	5	μA	
I ₃	3-Level Input DC Current	HIGH, V _{IN} = V _{DD}	3-Level Inputs, (TEST, FS, nF[1:0], DS[1:0], PD#/DIV, PE/HD)	–	200	μA
		MID, V _{IN} = V _{DD} /2		–50	50	μA
		LOW, V _{IN} = V _{SS}		–200	–	μA
I _{PU}	Input Pull Up Current	V _{IN} = V _{SS} , V _{DD} = Max	–25	–	μA	
I _{PD}	Input Pull Down Current	V _{IN} = V _{DD} , V _{DD} = Max, (sOE#)	–	100	μA	
V _{OL}	Output LOW Voltage	I _{OL} = 12 mA (PE/HD = L/H), (nQ[0:1])	–	0.4	V	
		I _{OL} = 24 mA (PE/HD = MID), (nQ[0:1])	–	0.4	V	
		I _{OL} = 2 mA (LOCK)	–	0.4	V	
V _{OH}	Output HIGH Voltage	I _{OH} = –12 mA (PE/HD = L/H), (nQ[0:1])	2.4	–	V	
		I _{OH} = –24 mA (PE/HD = MID), (nQ[0:1])	2.4	–	V	
		I _{OH} = –2 mA (LOCK)	2.4	–	V	
I _{DDQ}	Quiescent Supply Current	V _{DD} = Max, TEST = MID, REF = LOW, sOE# = LOW, Outputs Not Loaded	–	2	mA	
I _{DDPD}	Power Down Current	PD#/DIV, sOE# = LOW, Test, nF[1:0], DS[1:0] = HIGH, V _{DD} = Max	10(typ.)	25	μA	
I _{DD}	Dynamic Supply Current	At 100 MHz	230		mA	
C _{IN}	Input Pin Capacitance		4		pF	

Note

12. These Inputs are normally wired to V_{DD}, GND or unconnected. Internal termination resistors bias unconnected inputs to V_{DD}/2.

Thermal Resistance

Parameter ^[13]	Description	Test Conditions	44-pin TQFP	Unit
θ_{JA}	Thermal resistance (junction to ambient)	Test conditions follow standard test methods and procedures for measuring thermal impedance, in accordance with EIA/JESD51.	54	°C/W
θ_{JC}	Thermal resistance (junction to case)		10	°C/W

AC Test Loads and Waveforms

Figure 2. For Lock Output and all other Outputs

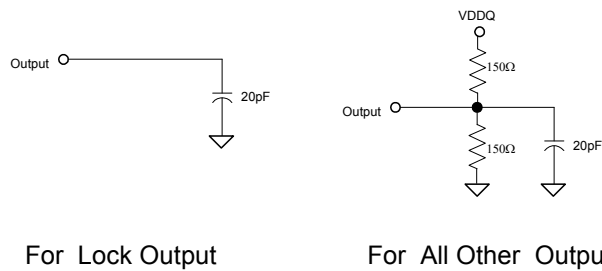

Figure 3. 3.3V LVTTTL and 2.5V LVTTTL Output Waveforms

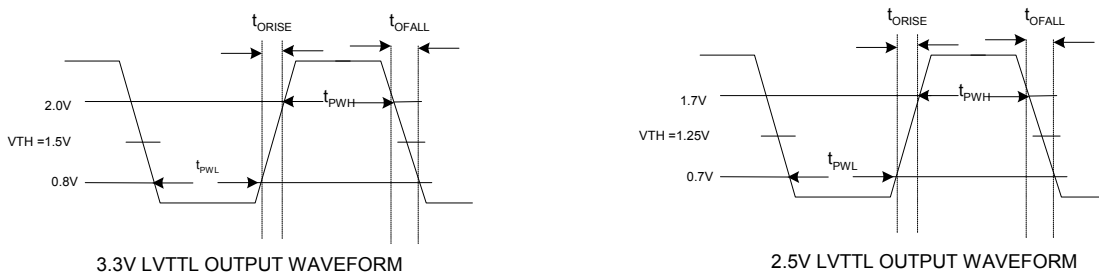
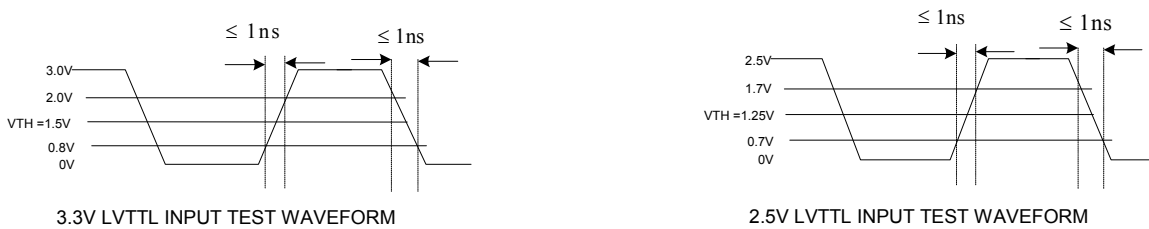

Figure 4. 3.3 V LVTTTL and 2.5 V LVTTTL Input Test Waveforms



Note

13. These parameters are guaranteed by design and are not tested.

AC Input Specifications

Parameter	Description	Condition	Min	Max	Unit
T_{R,T_F}	Input Rise/Fall Time	0.8 V – 2.0 V	–	10	ns/V
T_{PWC}	Input Clock Pulse	HIGH or LOW	2	–	ns
T_{DCIN}	Input Duty Cycle		10	90	%
F_{REF}	Reference Input Frequency ^[14]	FS = LOW	2	50	MHz
		FS = MID	4	100	
		FS = HIGH	8	200	

Note

14. If PD#/DIV is in HIGH level (R-reference divider = 1). Reference Input Frequency = F_{REF} . IF PD#/DIV is in MID level (R-reference divider = 2). Reference Input Frequency = $F_{REF} \times 2$.

Switching Characteristics

Parameter	Description	Condition	Min	Type	Max	Unit
F _{OR}	Output frequency range		6	–	200	MHz
VCO _{LR}	VCO Lock Range		200	–	400	MHz
VCO _{LBW}	VCO Loop Bandwidth		0.25	–	3.5	MHz
t _{SKEWPR}	Matched-Pair Skew ^[15]	Skew between the earliest and the latest output transitions within the same bank.	–	–	100	ps
t _{SKEW0}	Output-Output Skew ^[15]	Skew between the earliest and the latest output transitions among all outputs at 0t _J .	–	–	200	ps
t _{SKEW1}		Skew between the earliest and the latest output transitions among all outputs for which the same phase delay has been selected.	–	–	200	ps
t _{SKEW2}		Skew between the nominal output rising edge to the inverted output falling edge.	–	–	500	ps
t _{SKEW3}		Skew between non-inverted outputs running at different frequencies.	–	–	500	ps
t _{SKEW4}	Output-Output Skew ^[15]	Skew between nominal to inverted outputs running at different frequencies.	–	–	500	ps
t _{SKEW5}		Skew between nominal outputs at different power supply levels.	–	–	650	ps
t _{PART}	Part-Part Skew	Skew between the outputs of any two devices under identical settings and conditions (V _{DDQ} , V _{DD} , temp, air flow, frequency, etc.).	–	–	750	ps
t _{PD0}	Ref to FB Propagation Delay ^[16]		–250	–	+250	ps
t _{ODCV}	Output Duty Cycle	F _{out} < 100 MHz, Measured at V _{DD} /2.	48	–	52	%
		F _{out} > 100 MHz, Measured at V _{DD} /2.	45	–	55	
t _{PWH}	Output High Time Deviation from 50%	Measured at 2.0 V for V _{DD} = 3.3 V and at 1.7 V for V _{DD} = 2.5 V.	–	–	1.5	ns
t _{PWL}	Output Low Time Deviation from 50%	Measured at 0.8 V for V _{DD} = 3.3 V and at 0.7 V for V _{DD} = 2.5 V.	–	–	2.0	ns
t _R /t _F	Output Rise/Fall Time	Measured at 0.8 V–2.0 V for V _{DD} = 3.3 V and 0.7 V–1.7 V for V _{DD} = 2.5 V.	0.15	–	1.5	ns
t _{LOCK}	PLL Lock Time ^[17, 18]		–	–	0.5	ms
t _{CCJ}	Cycle-Cycle Jitter	Divide by one output frequency, FS = L, FB = divide by any.	–	45	100	ps
		Divide by one output frequency, FS = M/H, FB = divide by any.	–	55	150	ps

Notes

15. Test Load = 20 pF, terminated to V_{CC}/2. All outputs are equally loaded.

16. t_{PD} is measured at 1.5 V for V_{DD} = 3.3 V and at 1.25 V for V_{DD} = 2.5 V with REF rise/fall times of 0.5 ns between 0.8 V–2.0 V.

17. t_{LOCK} is the time that is required before outputs synchronize to REF. This specification is valid with stable power supplies which are within normal operating limits.

18. Lock detector circuit may be unreliable for input frequencies lower than 4 MHz, or for input signals which contain significant jitter.

AC Timing Definitions

Figure 5. Timing Definition

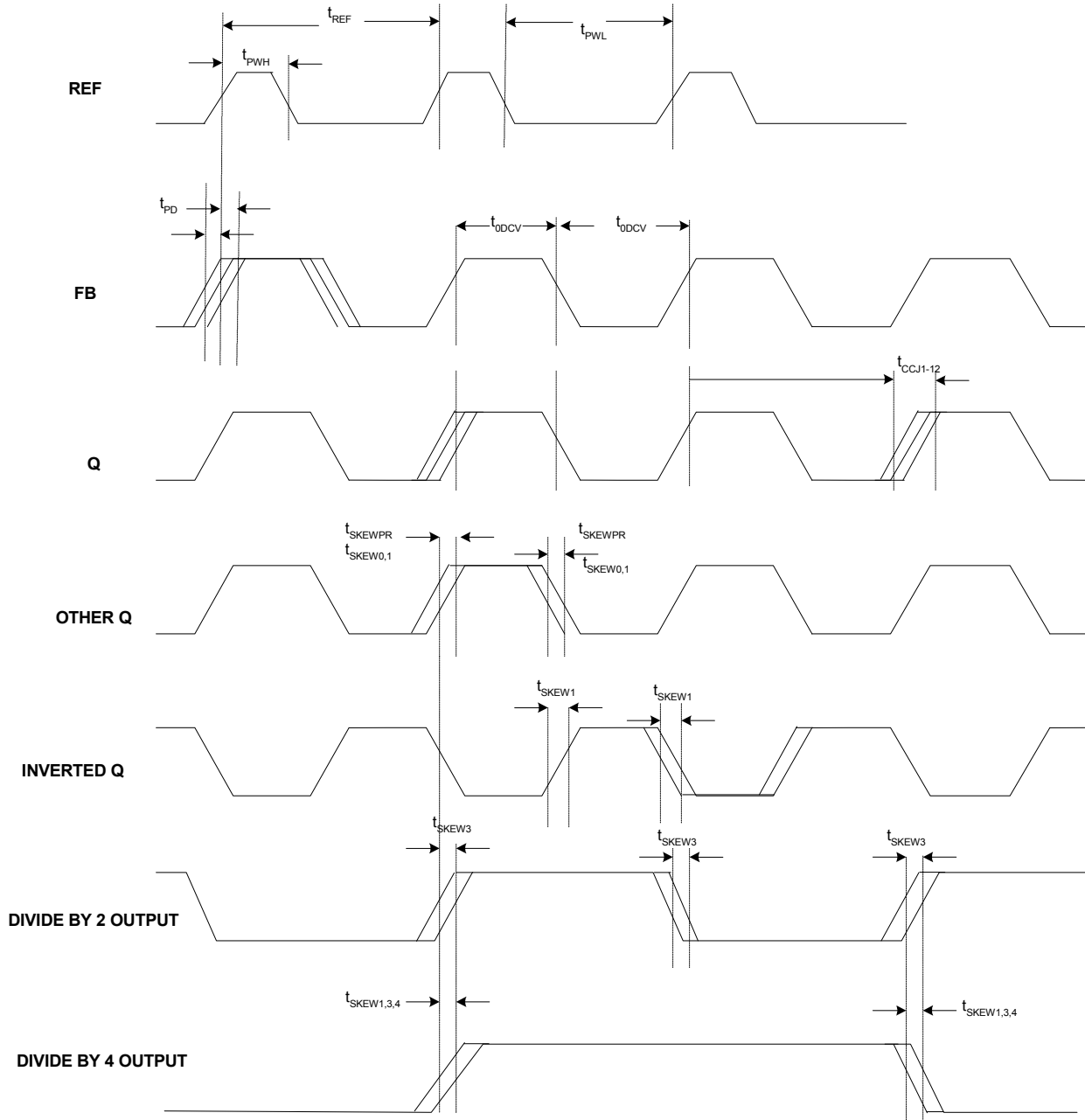

With PE HIGH (LOW), the REF rising (falling) edges are aligned to the FB rising (falling) edges. Also, when PE is HIGH (LOW), all divided outputs' rising (falling) edges are aligned to the rising (falling) edges of the undivided, non-inverted outputs. Regardless of PE setting, divide-by-4 outputs' rising edges align to the divide-by-2 outputs' rising edges.

degrees phase aligned to the REF input rising edges (as set randomly at power-up). If the divided outputs are required as rising-edge (falling-edge) aligned to the REF input's rising (falling) edge, set the PE pin HIGH (LOW) and connect the lowest frequency divided output to the FB input pin. This setup provides a consistent input-output and output-output phase relationship.

In cases where a non-divided output is connected to the FB input pin, the divided output rising edges can be either 0 or 180

Ordering Information

Part Number	Package Type	Product Flow	Status
Pb-free			
CY7B995AXI	44-pin TQFP	Industrial, -40 °C to 85 °C	Active
CY7B995AXIT	44-pin TQFP – Tape and Reel	Industrial, -40 °C to 85 °C	Active

Ordering Code Definitions

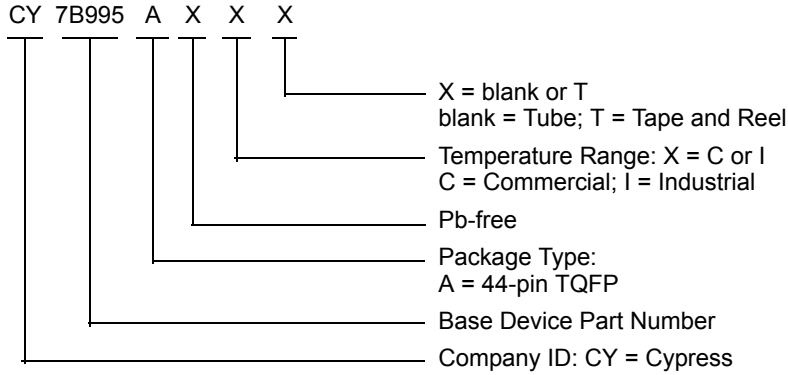

Package Drawing and Dimension

Figure 6. 44-pin TQFP (10 × 10 × 1.0 mm) Package Outline, 51-85155

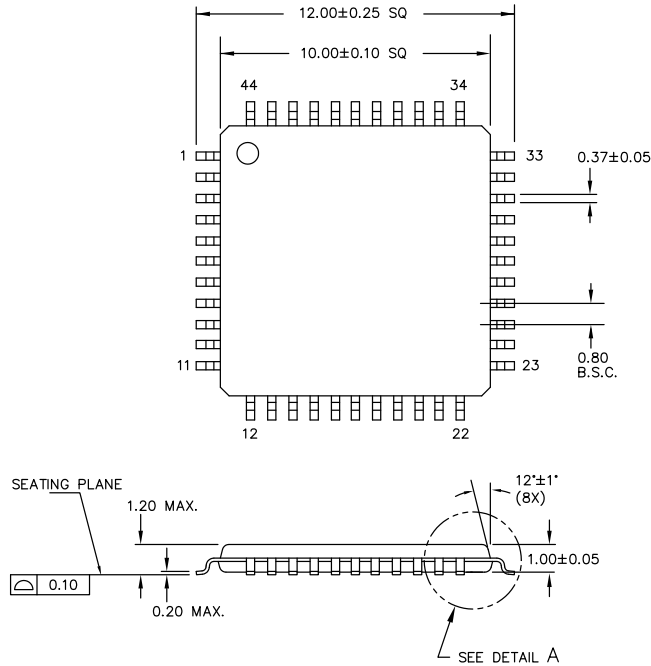

DIMENSIONS ARE IN MILLIMETERS
 Package Weight – Refer to PMDD spec.

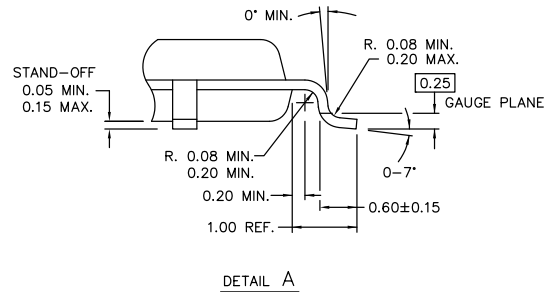

51-85155 *D

Acronyms

Acronym	Description
CMOS	Complementary Metal Oxide Semiconductor
ESD	Electrostatic Discharge
LVC MOS	Low Voltage Complementary Metal Oxide Semiconductor
LV TTL	Low Voltage Transistor-Transistor Logic
PLL	Phase Locked Loop
TQFP	Thin Quad Flat Pack
VCO	Voltage-Controlled Oscillator

Document Conventions

Units of Measure

Symbol	Unit of Measure
°C	degree Celsius
Hz	hertz
kHz	kilohertz
MHz	megahertz
μA	microampere
mA	milliampere
ms	millisecond
mV	millivolt
ns	nanosecond
Ω	ohm
ppm	parts per million
%	percent
pF	picofarad
ps	picosecond
V	volt
W	watt

Document History Page

Document Title: CY7B995 RoboClock®, 2.5/3.3 V 200 MHz High-Speed Multi-Phase PLL Clock Buffer Document Number: 38-07337				
Rev.	ECN No.	Issue Date	Orig. of Change	Description of Change
**	122626	01/10/03	RGL	New data sheet.
*A	205743	See ECN	RGL	Changed Pin 5 from VDD to VDDQ4, Pin 16 from VDD to VDDQ3 and Pin 29 from VDD to VDDQ1 Added pin 1 indicator in the Pin Configuration Drawing
*B	362760	See ECN	RGL	Added description on the AC Timing Waveforms Added typical value for cycle-to-cycle jitter
*C	389237	See ECN	RGL	Added Lead-free devices
*D	1562063	See ECN	PYG / AESA	Added Status column to Ordering Information table
*E	2892312	03/15/2010	CXQ	Added Table of Contents Removed part numbers CY7B995AC, CY7B995ACT, CY7B995AI and CY7B995AIT in ordering information table. Updated package diagram (Figure 6) Added Sales, Solutions, and Legal Information
*F	3162976	02/04/2011	CXQ	Added Ordering Code Definitions under Ordering Information . Added Acronyms and Units of Measure . Minor edits and updated in new template.
*G	4312848	03/18/2014	CINM	Updated Package Drawing and Dimension : spec 51-85155 – Changed revision from *B to *D. Updated to new template. Completing Sunset Review.
*H	4570146	11/14/2014	CINM	Updated Functional Description : Added “For a complete list of related documentation, click here .” at the end.
*I	5257087	05/03/2016	PSR	Added Thermal Resistance . Updated to new template.

Sales, Solutions, and Legal Information

Worldwide Sales and Design Support

Cypress maintains a worldwide network of offices, solution centers, manufacturer's representatives, and distributors. To find the office closest to you, visit us at [Cypress Locations](#).

Products

ARM® Cortex® Microcontrollers	cypress.com/arm
Automotive	cypress.com/automotive
Clocks & Buffers	cypress.com/clocks
Interface	cypress.com/interface
Lighting & Power Control	cypress.com/powerpsoc
Memory	cypress.com/memory
PSoC	cypress.com/psoc
Touch Sensing	cypress.com/touch
USB Controllers	cypress.com/usb
Wireless/RF	cypress.com/wireless

PSoC® Solutions

[PSoC 1](#) | [PSoC 3](#) | [PSoC 4](#) | [PSoC 5LP](#)

Cypress Developer Community

[Forums](#) | [Projects](#) | [Video](#) | [Blogs](#) | [Training](#) | [Components](#)

Technical Support

cypress.com/support



© Cypress Semiconductor Corporation, 2003-2016. This document is the property of Cypress Semiconductor Corporation and its subsidiaries, including Spansion LLC ("Cypress"). This document, including any software or firmware included or referenced in this document ("Software"), is owned by Cypress under the intellectual property laws and treaties of the United States and other countries worldwide. Cypress reserves all rights under such laws and treaties and does not, except as specifically stated in this paragraph, grant any license under its patents, copyrights, trademarks, or other intellectual property rights. If the Software is not accompanied by a license agreement and you do not otherwise have a written agreement with Cypress governing the use of the Software, then Cypress hereby grants you a personal, non-exclusive, nontransferable license (without the right to sublicense) (1) under its copyright rights in the Software (a) for Software provided in source code form, to modify and reproduce the Software solely for use with Cypress hardware products, only internally within your organization, and (b) to distribute the Software in binary code form externally to end users (either directly or indirectly through resellers and distributors), solely for use on Cypress hardware product units, and (2) under those claims of Cypress's patents that are infringed by the Software (as provided by Cypress, unmodified) to make, use, distribute, and import the Software solely for use with Cypress hardware products. Any other use, reproduction, modification, translation, or compilation of the Software is prohibited.

TO THE EXTENT PERMITTED BY APPLICABLE LAW, CYPRESS MAKES NO WARRANTY OF ANY KIND, EXPRESS OR IMPLIED, WITH REGARD TO THIS DOCUMENT OR ANY SOFTWARE OR ACCOMPANYING HARDWARE, INCLUDING, BUT NOT LIMITED TO, THE IMPLIED WARRANTIES OF MERCHANTABILITY AND FITNESS FOR A PARTICULAR PURPOSE. To the extent permitted by applicable law, Cypress reserves the right to make changes to this document without further notice. Cypress does not assume any liability arising out of the application or use of any product or circuit described in this document. Any information provided in this document, including any sample design information or programming code, is provided only for reference purposes. It is the responsibility of the user of this document to properly design, program, and test the functionality and safety of any application made of this information and any resulting product. Cypress products are not designed, intended, or authorized for use as critical components in systems designed or intended for the operation of weapons, weapons systems, nuclear installations, life-support devices or systems, other medical devices or systems (including resuscitation equipment and surgical implants), pollution control or hazardous substances management, or other uses where the failure of the device or system could cause personal injury, death, or property damage ("Unintended Uses"). A critical component is any component of a device or system whose failure to perform can be reasonably expected to cause the failure of the device or system, or to affect its safety or effectiveness. Cypress is not liable, in whole or in part, and you shall and hereby do release Cypress from any claim, damage, or other liability arising from or related to all Unintended Uses of Cypress products. You shall indemnify and hold Cypress harmless from and against all claims, costs, damages, and other liabilities, including claims for personal injury or death, arising from or related to any Unintended Uses of Cypress products.

Cypress, the Cypress logo, Spansion, the Spansion logo, and combinations thereof, PSoC, CapSense, EZ-USB, F-RAM, and Traveo are trademarks or registered trademarks of Cypress in the United States and other countries. For a more complete list of Cypress trademarks, visit cypress.com. Other names and brands may be claimed as property of their respective owners.

Looking for pricing, stock, or lifecycle information?

Click below to explore more details on WIN SOURCE:

-  [View CY7B995AXI on WIN SOURCE](#)
-  [Cypress Semiconductor Corp Information](#)

Optimize Your Supply Chain with WIN SOURCE Solutions

-  Global Sourcing Solution
-  Obsolete Management
-  Cost Control Management
-  Shortage Management
-  Alternative Solution
-  Excess Inventory Management