



**THE DATASHEET OF  
MC14016BCPG**



# MC14016B

## Quad Analog Switch/ Quad Multiplexer

The MC14016B quad bilateral switch is constructed with MOS P-channel and N-channel enhancement mode devices in a single monolithic structure. Each MC14016B consists of four independent switches capable of controlling either digital or analog signals. The quad bilateral switch is used in signal gating, chopper, modulator, demodulator and CMOS logic implementation.

### Features

- Diode Protection on All Inputs
- Supply Voltage Range = 3.0 Vdc to 18 Vdc
- Linearized Transfer Characteristics
- Low Noise –  $12 \text{ nV}/\sqrt{\text{Cycle}}$ ,  $f \geq 1.0 \text{ kHz}$  typical
- Pin-for-Pin Replacements for CD4016B, CD4066B (Note Improved Transfer Characteristic Design Causes More Parasitic Coupling Capacitance than CD4016)
- For Lower  $R_{ON}$ , Use The HC4016 High-Speed CMOS Device or The MC14066B
- This Device Has Inputs and Outputs Which Do Not Have ESD Protection. Antistatic Precautions Must Be Taken
- NLV Prefix for Automotive and Other Applications Requiring Unique Site and Control Change Requirements; AEC-Q100 Qualified and PPAP Capable
- These Devices are Pb-Free and are RoHS Compliant

### MAXIMUM RATINGS (Voltages Referenced to $V_{SS}$ )

Symbol	Parameter	Value	Unit
$V_{DD}$	DC Supply Voltage Range	-0.5 to +18.0	V
$V_{in}, V_{out}$	Input or Output Voltage Range (DC or Transient)	-0.5 to $V_{DD} + 0.5$	V
$I_{in}$	Input Current (DC or Transient) per Control Pin	$\pm 10$	mA
$I_{SW}$	Switch Through Current	$\pm 25$	mA
$P_D$	Power Dissipation, per Package (Note 1)	500	mW
$T_A$	Ambient Temperature Range	-55 to +125	$^{\circ}\text{C}$
$T_{stg}$	Storage Temperature Range	-65 to +150	$^{\circ}\text{C}$
$T_L$	Lead Temperature (8-Second Soldering)	260	$^{\circ}\text{C}$

Stresses exceeding those listed in the Maximum Ratings table may damage the device. If any of these limits are exceeded, device functionality should not be assumed, damage may occur and reliability may be affected.

1. Temperature Derating: "D/DW" Packages:  $-7.0 \text{ mW}/^{\circ}\text{C}$  From  $65^{\circ}\text{C}$  To  $125^{\circ}\text{C}$

This device contains protection circuitry to guard against damage due to high static voltages or electric fields. However, precautions must be taken to avoid applications of any voltage higher than maximum rated voltages to this high-impedance circuit. For proper operation,  $V_{in}$  and  $V_{out}$  should be constrained to the range  $V_{SS} \leq (V_{in} \text{ or } V_{out}) \leq V_{DD}$ .

Unused inputs must always be tied to an appropriate logic voltage level (e.g., either  $V_{SS}$  or  $V_{DD}$ ). Unused outputs must be left open.



**ON Semiconductor®**

<http://onsemi.com>

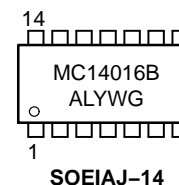
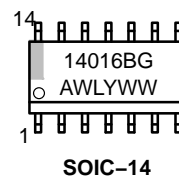


SOIC-14  
D SUFFIX  
CASE 751A



SOEIAJ-14  
F SUFFIX  
CASE 965

### MARKING DIAGRAMS



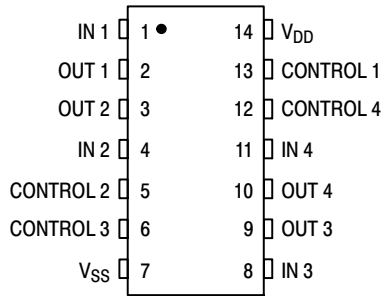
A = Assembly Location  
WL, L = Wafer Lot  
YY, Y = Year  
WW, W = Work Week  
G = Pb-Free Indicator

### ORDERING INFORMATION

See detailed ordering and shipping information in the package dimensions section on page 2 of this data sheet.

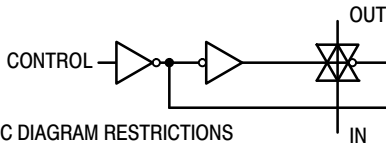
# MC14016B

## PIN ASSIGNMENT



## LOGIC DIAGRAM

(1/4 OF DEVICE SHOWN)

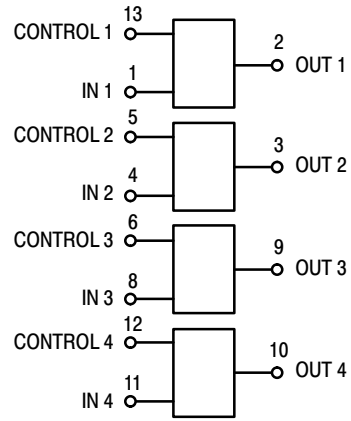


LOGIC DIAGRAM RESTRICTIONS

$$V_{SS} \leq V_{in} \leq V_{DD}$$

$$V_{SS} \leq V_{out} \leq V_{DD}$$

## BLOCK DIAGRAM



$V_{DD} = \text{PIN } 14$   
 $V_{SS} = \text{PIN } 7$

Control	Switch
0 = $V_{SS}$	Off
1 = $V_{DD}$	On

## ORDERING INFORMATION

Device	Package	Shipping <sup>†</sup>
MC14016BDG	SOIC-14 (Pb-Free)	55 Units / Rail
MC14016BDR2G	SOIC-14 (Pb-Free)	2500 / Tape & Reel
NLV14016BDR2G*	SOIC-14 (Pb-Free)	2500 / Tape & Reel
MC14016BFELG	SOEIAJ-14 (Pb-Free)	2000 / Tape & Reel

<sup>†</sup>For information on tape and reel specifications, including part orientation and tape sizes, please refer to our Tape and Reel Packaging Specifications Brochure, BRD8011/D.

\*NLV Prefix for Automotive and Other Applications Requiring Unique Site and Control Change Requirements; AEC-Q100 Qualified and PPAP Capable.

# MC14016B

## ELECTRICAL CHARACTERISTICS (Voltages Referenced to $V_{SS}$ )

Characteristic	Figure	Symbol	$V_{DD}$ Vdc	-55°C		25°C			125°C		Unit
				Min	Max	Min	Typ (Note 2)	Max	Min	Max	
Input Voltage Control Input	1	$V_{IL}$	5.0	-	-	-	1.5	0.9	-	-	Vdc
			10	-	-	-	1.5	0.9	-	-	
			15	-	-	-	1.5	0.9	-	-	
		$V_{IH}$	5.0	-	-	3.0	2.0	-	-	-	Vdc
			10	-	-	8.0	6.0	-	-	-	
			15	-	-	13	11	-	-	-	
Input Current Control	-	$I_{in}$	15	-	$\pm 0.1$	-	$\pm 0.00001$	$\pm 0.1$	-	$\pm 1.0$	$\mu\text{A}_{dc}$
Input Capacitance Control Switch Input Switch Output Feed Through	-	$C_{in}$	-	-	-	-	5.0	-	-	-	pF
			-	-	-	-	5.0	-	-	-	
			-	-	-	-	5.0	-	-	-	
			-	-	-	-	0.2	-	-	-	
Quiescent Current (Per Package) (Note 3)	2,3	$I_{DD}$	5.0	-	0.25	-	0.0005	0.25	-	7.5	$\mu\text{A}_{dc}$
			10	-	0.5	-	0.0010	0.5	-	15	
			15	-	1.0	-	0.0015	1.0	-	30	
"ON" Resistance ( $V_C = V_{DD}$ , $R_L = 10\text{ k}\Omega$ )  ( $V_{in} = +10\text{ Vdc}$ ) ( $V_{in} = +0.25\text{ Vdc}$ ) $V_{SS} = 0\text{ Vdc}$ ( $V_{in} = +5.6\text{ Vdc}$ )  ( $V_{in} = +15\text{ Vdc}$ ) ( $V_{in} = +0.25\text{ Vdc}$ ) $V_{SS} = 0\text{ Vdc}$ ( $V_{in} = +9.3\text{ Vdc}$ )	4,5,6	$R_{ON}$	-	-	600	-	260	660	-	840	$\Omega$
			-	-	600	-	310	660	-	840	
			10	-	600	-	310	660	-	840	
			-	-	360	-	260	400	-	520	
			-	-	360	-	260	400	-	520	
			15	-	360	-	300	400	-	520	
$\Delta$ "ON" Resistance Between any 2 circuits in a common package ( $V_C = V_{DD}$ ) ( $V_{in} = +5.0\text{ Vdc}$ , $V_{SS} = -5.0\text{ Vdc}$ ) ( $V_{in} = +7.5\text{ Vdc}$ , $V_{SS} = -7.5\text{ Vdc}$ )	-	$\Delta R_{ON}$	-	-	-	-	-	-	-	-	$\Omega$
			5.0	-	-	-	15	-	-	-	
			7.5	-	-	-	10	-	-	-	
Input/Output Leakage Current ( $V_C = V_{SS}$ ) ( $V_{in} = +7.5$ , $V_{out} = -7.5\text{ Vdc}$ ) ( $V_{in} = -7.5$ , $V_{out} = +7.5\text{ Vdc}$ )	-	-	7.5	-	$\pm 0.1$	-	$\pm 0.0015$	$\pm 0.1$	-	$\pm 1.0$	$\mu\text{A}_{dc}$
			7.5	-	$\pm 0.1$	-	$\pm 0.0015$	$\pm 0.1$	-	$\pm 1.0$	

Product parametric performance is indicated in the Electrical Characteristics for the listed test conditions, unless otherwise noted. Product performance may not be indicated by the Electrical Characteristics if operated under different conditions.

NOTE: All unused inputs must be returned to  $V_{DD}$  or  $V_{SS}$  as appropriate for the circuit application.

2. Data labelled "Typ" is not to be used for design purposes but is intended as an indication of the IC's potential performance.

3. For voltage drops across the switch ( $\Delta V_{switch}$ ) > 600 mV (> 300 mV at high temperature), excessive  $V_{DD}$  current may be drawn; i.e., the current out of the switch may contain both  $V_{DD}$  and switch input components. The reliability of the device will be unaffected unless the Maximum Ratings are exceeded. (See first page of this data sheet.) Reference Figure 14.

# MC14016B

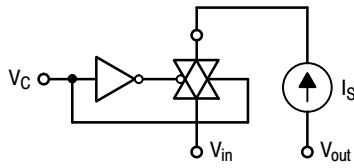
## ELECTRICAL CHARACTERISTICS (Note 4) ( $C_L = 50 \text{ pF}$ , $T_A = 25^\circ\text{C}$ )

Characteristic	Figure	Symbol	V <sub>DD</sub> Vdc	Min	Typ (Note 5)	Max	Unit
Propagation Delay Time ( $V_{SS} = 0 \text{ Vdc}$ ) $V_{in}$ to $V_{out}$ ( $V_C = V_{DD}$ , $R_L = 10 \text{ k}\Omega$ )	7	$t_{PLH}$ ,	5.0	–	15	45	ns
		$t_{PHL}$	10 15	– –	7.0 6.0	20 15	
Control to Output ( $V_{in} \leq 10 \text{ Vdc}$ , $R_L = 10 \text{ k}\Omega$ )	8	$t_{PHZ}$ ,	5.0	–	34	120	ns
		$t_{PLZ}$ ,	10	–	20	110	
		$t_{PZH}$ ,	15	–	15	100	
		$t_{PZL}$					
Crosstalk, Control to Output ( $V_{SS} = 0 \text{ Vdc}$ ) ( $V_C = V_{DD}$ , $R_{in} = 10 \text{ k}\Omega$ , $R_{out} = 10 \text{ k}\Omega$ , $f = 1.0 \text{ kHz}$ )	9	–	5.0	–	30	–	mV
			10	–	50	–	
			15	–	100	–	
Crosstalk between any two switches ( $V_{SS} = 0 \text{ Vdc}$ ) ( $R_L = 1.0 \text{ k}\Omega$ , $f = 1.0 \text{ MHz}$ , crosstalk = $20 \log_{10} \frac{V_{out1}}{V_{out2}}$ )	–	–	5.0	–	–80	–	dB
Noise Voltage ( $V_{SS} = 0 \text{ Vdc}$ ) ( $V_C = V_{DD}$ , $f = 100 \text{ Hz}$ )  ( $V_C = V_{DD}$ , $f = 100 \text{ kHz}$ )	10,11	–	5.0	–	24	–	nV/ $\sqrt{\text{Cycle}}$
			10	–	25	–	
			15	–	30	–	
			5.0	–	12	–	
			10	–	12	–	
			15	–	15	–	
Second Harmonic Distortion ( $V_{SS} = -5.0 \text{ Vdc}$ ) ( $V_{in} = 1.77 \text{ Vdc}$ , RMS Centered @ $0.0 \text{ Vdc}$ , $R_L = 10 \text{ k}\Omega$ , $f = 1.0 \text{ kHz}$ )	–	–	5.0	–	0.16	–	%
Insertion Loss ( $V_C = V_{DD}$ , $V_{in} = 1.77 \text{ Vdc}$ , $V_{SS} = -5.0 \text{ Vdc}$ , RMS centered = $0.0 \text{ Vdc}$ , $f = 1.0 \text{ MHz}$ )  $I_{loss} = 20 \log_{10} \frac{V_{out}}{V_{in}}$ ( $R_L = 1.0 \text{ k}\Omega$ ) ( $R_L = 10 \text{ k}\Omega$ ) ( $R_L = 100 \text{ k}\Omega$ ) ( $R_L = 1.0 \text{ M}\Omega$ )	12	–	5.0				dB
				–	2.3	–	
				–	0.2	–	
				–	0.1	–	
				–	0.05	–	
Bandwidth ( $-3.0 \text{ dB}$ ) ( $V_C = V_{DD}$ , $V_{in} = 1.77 \text{ Vdc}$ , $V_{SS} = -5.0 \text{ Vdc}$ , RMS centered @ $0.0 \text{ Vdc}$ ) ( $R_L = 1.0 \text{ k}\Omega$ ) ( $R_L = 10 \text{ k}\Omega$ ) ( $R_L = 100 \text{ k}\Omega$ ) ( $R_L = 1.0 \text{ M}\Omega$ )	12,13	BW	5.0				MHz
				–	54	–	
				–	40	–	
				–	38	–	
				–	37	–	
OFF Channel Feedthrough Attenuation ( $V_{SS} = -5.0 \text{ Vdc}$ ) ( $V_C = V_{SS}$ , $20 \log_{10} \frac{V_{out}}{V_{in}} = -50 \text{ dB}$ ) ( $R_L = 1.0 \text{ k}\Omega$ ) ( $R_L = 10 \text{ k}\Omega$ ) ( $R_L = 100 \text{ k}\Omega$ ) ( $R_L = 1.0 \text{ M}\Omega$ )	–	–	5.0				kHz
				–	1250	–	
				–	140	–	
				–	18	–	
				–	2.0	–	
				–			

4. The formulas given are for typical characteristics only at  $25^\circ\text{C}$ .

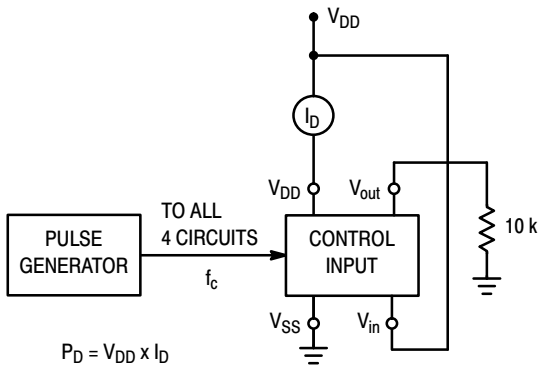
5. Data labelled "Typ" is not to be used for design purposes but is intended as an indication of the IC's potential performance.

# MC14016B

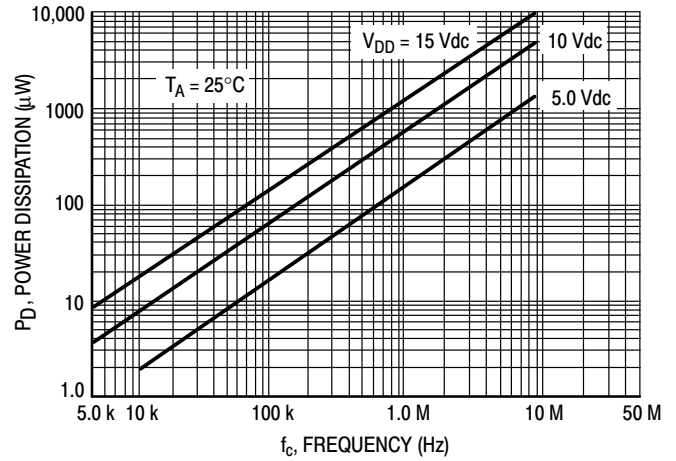


$V_{IL}$ :  $V_C$  is raised from  $V_{SS}$  until  $V_C = V_{IL}$ .  
 at  $V_C = V_{IL}$ :  $I_S = \pm 10 \mu A$  with  $V_{in} = V_{SS}$ ,  $V_{out} = V_{DD}$  or  $V_{in} = V_{DD}$ ,  $V_{out} = V_{SS}$ .  
 $V_{IH}$ : When  $V_C = V_{IH}$  to  $V_{DD}$ , the switch is ON and the  $R_{ON}$  specifications are met.

**Figure 1. Input Voltage Test Circuit**

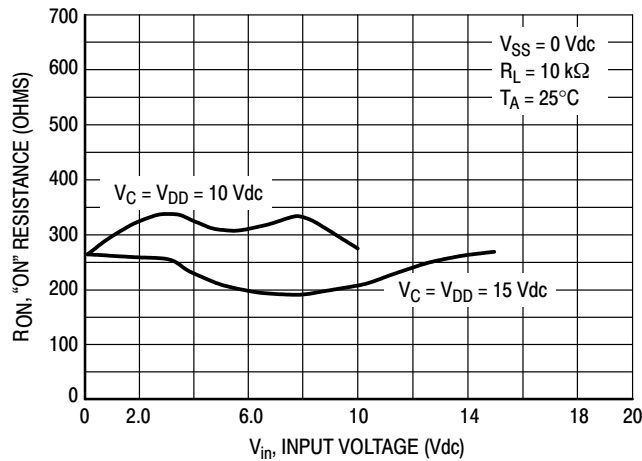


**Figure 2. Quiescent Power Dissipation Test Circuit**



**Figure 3. Typical Power Dissipation per Circuit (1/4 of device shown)**

## TYPICAL $R_{ON}$ versus INPUT VOLTAGE



**Figure 4.  $V_{SS} = 0 V$**

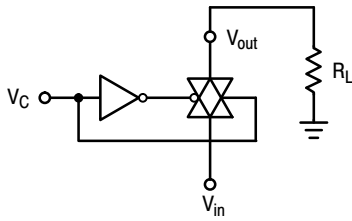


Figure 5.  $R_{ON}$  Characteristics Test Circuit

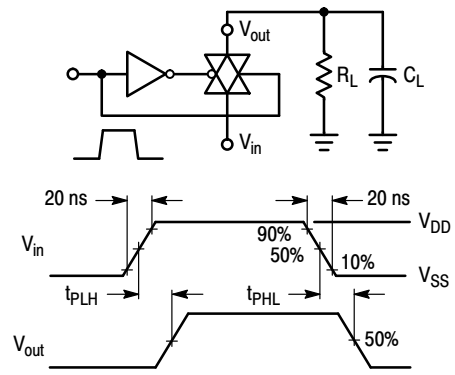


Figure 6. Propagation Delay Test Circuit and Waveforms

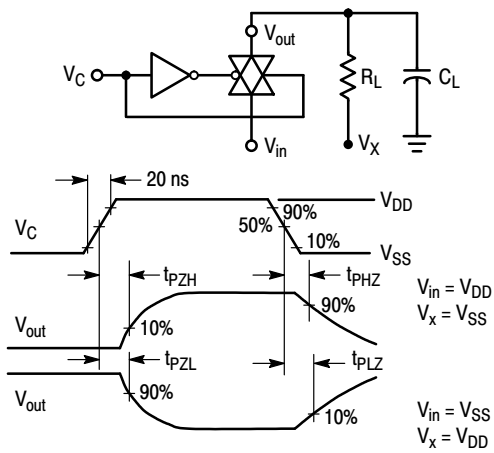


Figure 7. Turn-On Delay Time Test Circuit and Waveforms

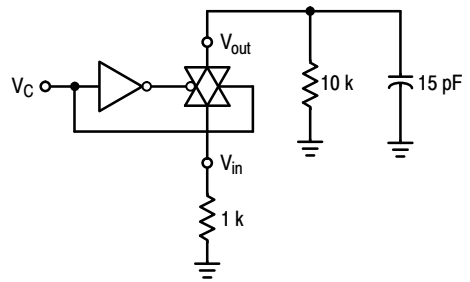


Figure 8. Crosstalk Test Circuit

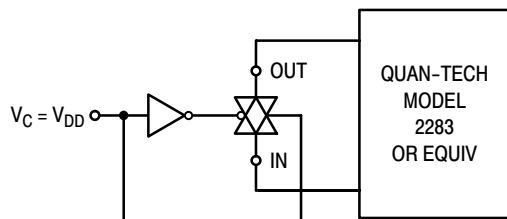


Figure 9. Noise Voltage Test Circuit

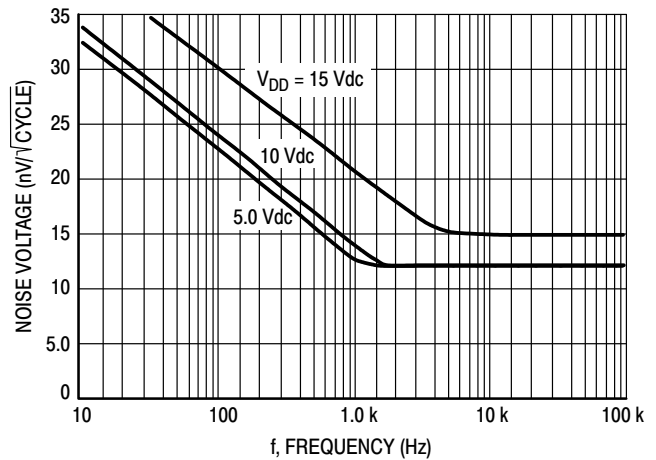
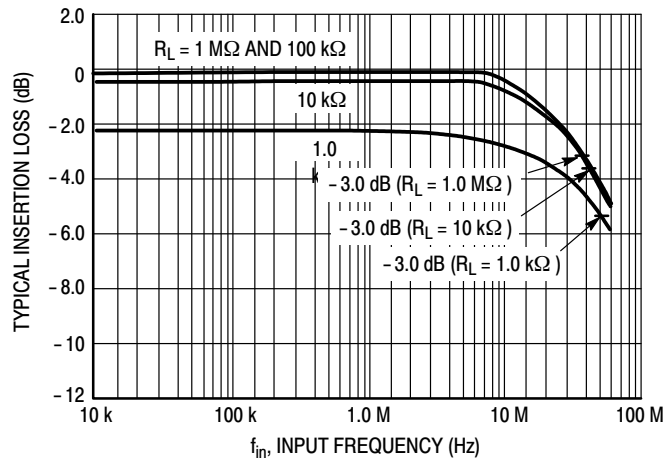
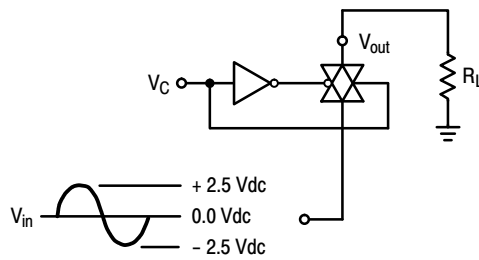


Figure 10. Typical Noise Characteristics

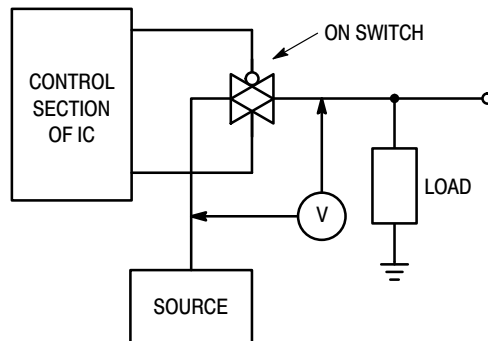
# MC14016B



**Figure 11. Typical Insertion Loss/Bandwidth Characteristics**



**Figure 12. Frequency Response Test Circuit**



**Figure 13.  $\Delta V$  Across Switch**

# MC14016B

## APPLICATIONS INFORMATION

Figure A illustrates use of the Analog Switch. The 0-to-5 V Digital Control signal is used to directly control a 5 V<sub>p-p</sub> analog signal.

The digital control logic levels are determined by V<sub>DD</sub> and V<sub>SS</sub>. The V<sub>DD</sub> voltage is the logic high voltage; the V<sub>SS</sub> voltage is logic low. For the example, V<sub>DD</sub> = +5 V logic high at the control inputs; V<sub>SS</sub> = GND = 0 V logic low.

The maximum analog signal level is determined by V<sub>DD</sub> and V<sub>SS</sub>. The analog voltage must not swing higher than V<sub>DD</sub> or lower than V<sub>SS</sub>.

The example shows a 5 V<sub>p-p</sub> signal which allows no margin at either peak. If voltage transients above V<sub>DD</sub> and/or below V<sub>SS</sub> are anticipated on the analog channels, external diodes (D<sub>x</sub>) are recommended as shown in Figure B. These diodes should be small signal types able to absorb the maximum anticipated current surges during clipping.

The *absolute* maximum potential difference between V<sub>DD</sub> and V<sub>SS</sub> is 18.0 V. Most parameters are specified up to 15 V which is the *recommended* maximum difference between V<sub>DD</sub> and V<sub>SS</sub>.

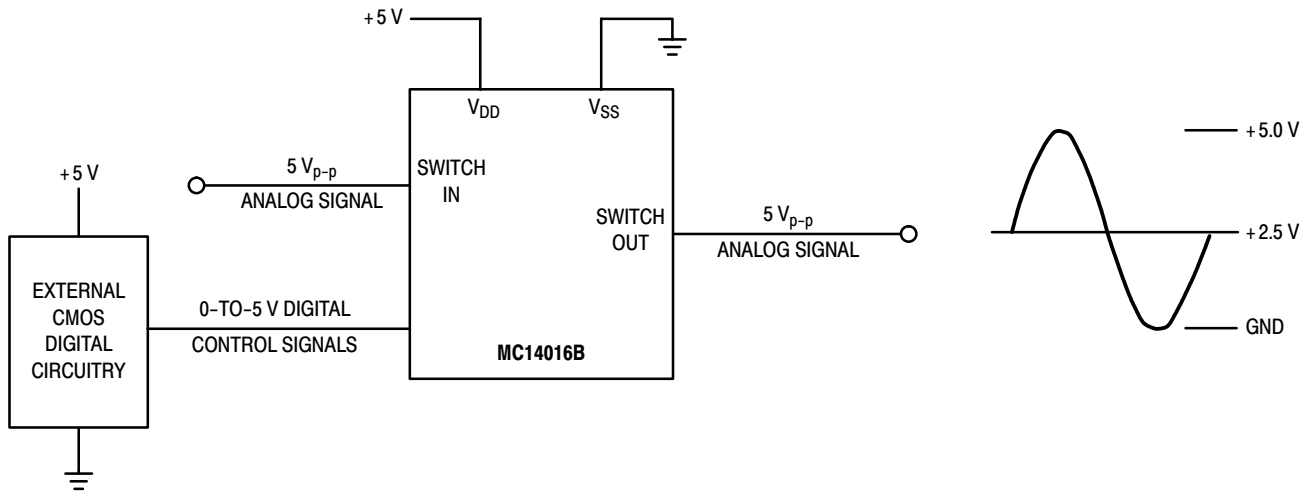


Figure A. Application Example

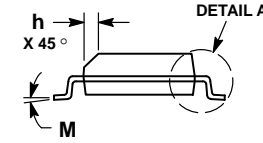
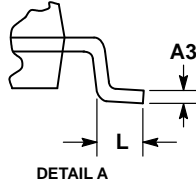
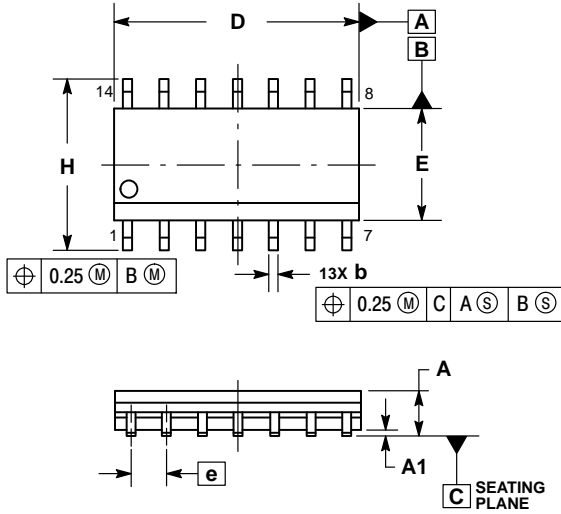


Figure B. External Germanium or Schottky Clipping Diodes

# MC14016B

## PACKAGE DIMENSIONS

SOIC-14 NB  
CASE 751A-03  
ISSUE K

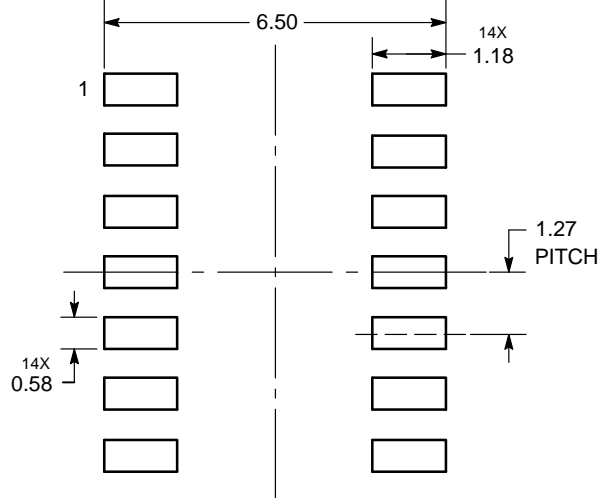


NOTES:

1. DIMENSIONING AND TOLERANCING PER ASME Y14.5M, 1994.
2. CONTROLLING DIMENSION: MILLIMETERS.
3. DIMENSION b DOES NOT INCLUDE DAMBAR PROTRUSION. ALLOWABLE PROTRUSION SHALL BE 0.13 TOTAL IN EXCESS OF AT MAXIMUM MATERIAL CONDITION.
4. DIMENSIONS D AND E DO NOT INCLUDE MOLD PROTRUSIONS.
5. MAXIMUM MOLD PROTRUSION 0.15 PER SIDE.

DIM	MILLIMETERS		INCHES	
	MIN	MAX	MIN	MAX
A	1.35	1.75	0.054	0.068
A1	0.10	0.25	0.004	0.010
A3	0.19	0.25	0.008	0.010
b	0.35	0.49	0.014	0.019
D	8.55	8.75	0.337	0.344
E	3.80	4.00	0.150	0.157
e	1.27 BSC		0.050 BSC	
H	5.80	6.20	0.228	0.244
h	0.25	0.50	0.010	0.019
L	0.40	1.25	0.016	0.049
M	0°	7°	0°	7°

### SOLDERING FOOTPRINT\*



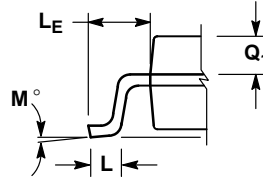
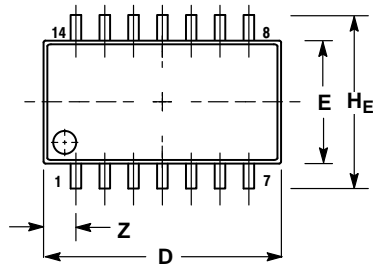
DIMENSIONS: MILLIMETERS

\*For additional information on our Pb-Free strategy and soldering details, please download the ON Semiconductor Soldering and Mounting Techniques Reference Manual, SOLDERRM/D.

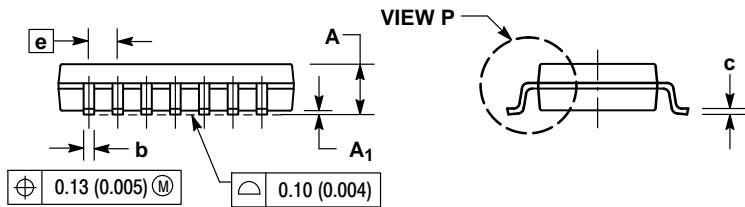
# MC14016B

## PACKAGE DIMENSIONS

SOEIAJ-14  
CASE 965  
ISSUE B



DETAIL P




VIEW P

### NOTES:

1. DIMENSIONING AND TOLERANCING PER ANSI Y14.5M, 1982.
2. CONTROLLING DIMENSION: MILLIMETER.
3. DIMENSIONS D AND E DO NOT INCLUDE MOLD FLASH OR PROTRUSIONS AND ARE MEASURED AT THE PARTING LINE. MOLD FLASH OR PROTRUSIONS SHALL NOT EXCEED 0.15 (0.006) PER SIDE.
4. TERMINAL NUMBERS ARE SHOWN FOR REFERENCE ONLY.
5. THE LEAD WIDTH DIMENSION (b) DOES NOT INCLUDE DAMBAR PROTRUSION. ALLOWABLE DAMBAR PROTRUSION SHALL BE 0.08 (0.003) TOTAL IN EXCESS OF THE LEAD WIDTH DIMENSION AT MAXIMUM MATERIAL CONDITION. DAMBAR CANNOT BE LOCATED ON THE LOWER RADIUS OR THE FOOT. MINIMUM SPACE BETWEEN PROTRUSIONS AND ADJACENT LEAD TO BE 0.46 (0.018).

DIM	MILLIMETERS		INCHES	
	MIN	MAX	MIN	MAX
A	---	2.05	---	0.081
A <sub>1</sub>	0.05	0.20	0.002	0.008
b	0.35	0.50	0.014	0.020
c	0.10	0.20	0.004	0.008
D	9.90	10.50	0.390	0.413
E	5.10	5.45	0.201	0.215
e	1.27 BSC		0.050 BSC	
H <sub>E</sub>	7.40	8.20	0.291	0.323
L	0.50	0.85	0.020	0.033
L <sub>E</sub>	1.10	1.50	0.043	0.059
M	0°	10°	0°	10°
Q <sub>1</sub>	0.70	0.90	0.028	0.035
Z	---	1.42	---	0.056

ON Semiconductor and the  are registered trademarks of Semiconductor Components Industries, LLC (SCILLC) or its subsidiaries in the United States and/or other countries. SCILLC owns the rights to a number of patents, trademarks, copyrights, trade secrets, and other intellectual property. A listing of SCILLC's product/patent coverage may be accessed at [www.onsemi.com/site/pdf/Patent-Marking.pdf](http://www.onsemi.com/site/pdf/Patent-Marking.pdf). SCILLC reserves the right to make changes without further notice to any products herein. SCILLC makes no warranty, representation or guarantee regarding the suitability of its products for any particular purpose, nor does SCILLC assume any liability arising out of the application or use of any product or circuit, and specifically disclaims any and all liability, including without limitation special, consequential or incidental damages. "Typical" parameters which may be provided in SCILLC data sheets and/or specifications can and do vary in different applications and actual performance may vary over time. All operating parameters, including "Typicals" must be validated for each customer application by customer's technical experts. SCILLC does not convey any license under its patent rights nor the rights of others. SCILLC products are not designed, intended, or authorized for use as components in systems intended for surgical implant into the body, or other applications intended to support or sustain life, or for any other application in which the failure of the SCILLC product could create a situation where personal injury or death may occur. Should Buyer purchase or use SCILLC products for any such unintended or unauthorized application, Buyer shall indemnify and hold SCILLC and its officers, employees, subsidiaries, affiliates, and distributors harmless against all claims, costs, damages, and expenses, and reasonable attorney fees arising out of, directly or indirectly, any claim of personal injury or death associated with such unintended or unauthorized use, even if such claim alleges that SCILLC was negligent regarding the design or manufacture of the part. SCILLC is an Equal Opportunity/Affirmative Action Employer. This literature is subject to all applicable copyright laws and is not for resale in any manner.

### PUBLICATION ORDERING INFORMATION

#### LITERATURE FULFILLMENT:

Literature Distribution Center for ON Semiconductor  
P.O. Box 5163, Denver, Colorado 80217 USA  
Phone: 303-675-2175 or 800-344-3860 Toll Free USA/Canada  
Fax: 303-675-2176 or 800-344-3867 Toll Free USA/Canada  
Email: [orderlit@onsemi.com](mailto:orderlit@onsemi.com)

**N. American Technical Support:** 800-282-9855 Toll Free  
USA/Canada  
**Europe, Middle East and Africa Technical Support:**  
Phone: 421 33 790 2910  
**Japan Customer Focus Center**  
Phone: 81-3-5817-1050

**ON Semiconductor Website:** [www.onsemi.com](http://www.onsemi.com)

**Order Literature:** <http://www.onsemi.com/orderlit>

For additional information, please contact your local Sales Representative

## Looking for pricing, stock, or lifecycle information?

Click below to explore more details on WIN SOURCE:

 [View MC14016BCPG on WIN SOURCE](#)

 [ON Semiconductor](#) Information

## Optimize Your Supply Chain with WIN SOURCE Solutions

-  Global Sourcing Solution
-  Obsolete Management
-  Cost Control Management
-  Shortage Management
-  Alternative Solution
-  Excess Inventory Management