



**THE DATASHEET OF
SG1845Y**



Current Mode PWM Controller

Description

The SG1844/45 family of control ICs provides all the required features to implement off-line Fixed Frequency, Current-mode switching power supplies with a minimum number of external components. Current-mode architecture demonstrates improved line regulation, improved load regulation, pulse-by-pulse current limiting and inherent protection of the power supply output switch.

The Bandgap reference is trimmed to $\pm 1\%$ over temperature. Oscillator discharge current is trimmed to less than $\pm 10\%$. The SG1844/45 has under-voltage lockout, current-limiting circuitry and start-up current of less than 1mA. The totem-pole output is optimized to drive the gate of a power MOSFET. The output is low in the off state to provide direct interface to an N-channel device. Both operate up to a maximum duty cycle range of zero to $< 50\%$ due to an internal toggle flip-flop which blanks the output off every other clock cycle. The SG1844/45 is specified for operation over the full military ambient temperature range of -55°C to 125°C . The SG3844/45 is designed for the commercial range of 0°C to 70°C .

Features

- Optimized for Off-Line Control
- Low Start-Up Current ($< 1\text{mA}$)
- Automatic Feed Forward Compensation
- Trimmed Oscillator
- Discharge Current
- Pulse-By-Pulse Current Limiting
- Enhanced Load Response Characteristics
- Undervoltage Lockout with 6V Hysteresis (SG1844 only)
- Double Pulse Suppression
- High-Current Totem-Pole Output
- Internally Trimmed Bandgap Reference
- 500kHz Operation
- Under-voltage Lockout
- SG1844 - 16 Volts
- SG1845 - 8.4 Volts
- Low Shoot-through Current $< 75\text{mA}$ Over Temperature

Application

- Available to MIL-STD-883
- Available to DSCC
 - Standard Microcircuit Drawing (SMD)
- SGR1844/45 Rad-Tolerant Version Available

Product Highlight

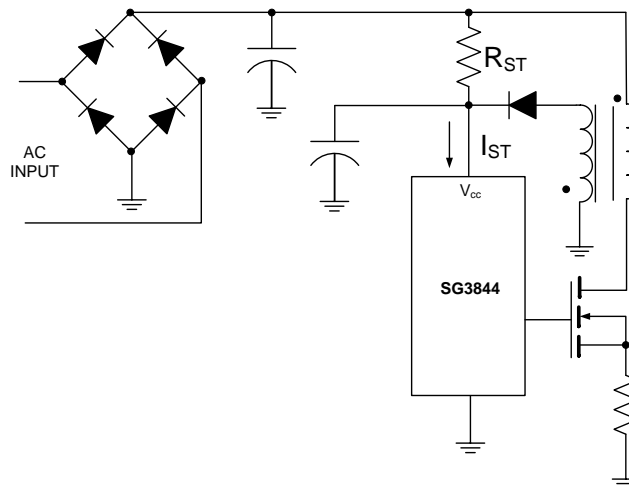
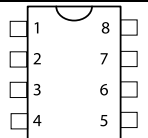
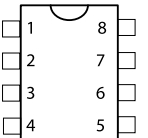
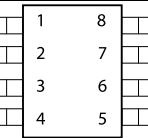
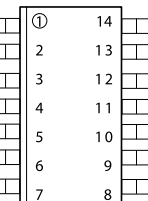

Figure 1 - Product Highlight

Connection Diagrams and Ordering Information

Ambient Temperature	Type	Package	Part Number	Packaging Type	Connection Diagram
0°C to 70°C	M	8-PIN PLASTIC DUAL INLINE PACKAGE	SG3844M	PDIP	 <p>M PACKAGE (Top View)</p> <p>M Package: RoHS / Pb-free 100% Matte Tin Lead Finish</p>
			SG3845M		
-55°C to 125°C	Y	8-PIN CERAMIC DUAL INLINE PACKAGE	SG1844Y	CERDIP	 <p>Y PACKAGE (Top View)</p> <p>PbSn Tin Lead Finish</p>
			SG1845Y		
			SG1844Y-883B		
			SG1845Y-883B		
			SG1844Y-DESC		
			SG1845Y-DESC		
0°C to 70°C	DM	8-PIN SMALL OUTLINE INTEGRATED CIRCUIT	SG3844DM	SOIC	 <p>DM PACKAGE (Top View)</p> <p>RoHS / Pb-free 100% Matte Tin Lead Finish</p>
			SG3845DM		
0°C to 70°C	D	14-PIN SMALL OUTLINE INTEGRATED CIRCUIT	SG3844D	SOIC	 <p>D PACKAGE (Top View)</p> <p>RoHS / Pb-free 100% Matte Tin Lead Finish</p>
			SG3845D		

Ambient Temperature		Package	Part Number	Packaging Type	Connection Diagram
-55°C to 125°C	J	14-PIN CERAMIC DUAL INLINE PACKAGE	SG1844J	CERDIP	<p>J PACKAGE (Top View) PbSn Lead Finish</p>
			SG1845J		
			SG1844J-883B		
			SG1845J-883B		
			SG1844J-DESC		
			SG1845J-DESC		
-55°C to 125°C	F	10-PIN CERAMIC FLAT PACK PACKAGE	SG1844F-DESC	FLAT PACK	<p>F PACKAGE (Top View) PbSn Lead Finish</p>
			SG1845F-DESC		
-55°C to 125°C	L	20-Pin CERAMIC	SG1844L	Ceramic (LCC) Leadless Chip Carrier	<p>L PACKAGE (Top View) PbSn Lead Finish</p>
			SG1845L		
			SG1844L-883B		
			SG1845L-883B		
			SG1844L-DESC		
			SG1845L-DESC		
<p>Notes:</p> <ol style="list-style-type: none"> Contact factory for DESC part availability. All parts are viewed from the top. Available in Tape & Reel. Append the letters "TR" to the part number. (i.e. SG3844D-TR) Hermetic Packages J, F, L, & Y use Pb37/Sn63 hot solder lead finish, contact factory for availability of RoHS versions. 					

Absolute Maximum Ratings^{1 - 2}

Parameter	Value	Units
Supply Voltage (Low Impedance Source)	30	V
Output Current (Peak)	±1	A
Output Current (Continuous)	350	mA
Output Energy (Capacitive Load)	5	μJ
Analog Inputs (V_{FB} , I_{SENSE})	-0.3 to +6.3	V
Error Amplifier Output Sink Current	10	mA
Operating Junction Temperature		
Hermetic (J, Y, F, L Packages)	150	°C
Plastic (M, D, DM Packages)	150	°C
Storage Temperature Range	-65 to +150	°C
Lead Temperature (Soldering, 10 Seconds)	300	°C
RoHS / Pb-free Peak Package Solder Reflow Temp. (40 second max. exposure)	260 (+0, -5)	°C
<i>Notes:</i>		
1. Exceeding these ratings could cause damage to the device.		
2. All voltages are with respect to Pin 5. All currents are positive into the specified terminal.		

Thermal Data

Parameter	Value	Units
M Package:		
Thermal Resistance-Junction to Ambient, θ_{JA}	95	°C/W
DM Package:		
Thermal Resistance-Junction to Ambient, θ_{JA}	165	°C/W
D Package:		
Thermal Resistance-Junction to Ambient, θ_{JA}	120	°C/W
Y Package:		
Thermal Resistance-Junction to Case, θ_{JC}	30	°C/W
Thermal Resistance-Junction to Ambient, θ_{JA}	130	°C/W
J Package		
Thermal Resistance-Junction to Case, θ_{JC}	30	°C/W
Thermal Resistance-Junction to Ambient, θ_{JA}	80	°C/W
F Package		
Thermal Resistance-Junction to Case, θ_{JC}	80	°C/W
Thermal Resistance-Junction to Ambient, θ_{JA}	145	°C/W
L Package		
Thermal Resistance-Junction to Case, θ_{JC}	35	°C/W
Thermal Resistance-Junction to Ambient, θ_{JA}	120	°C/W
<i>Notes:</i>		
Junction Temperature Calculation: $T_J = T_A + (P_D \times \theta_{JA})$.		
The θ_{JA} numbers are guidelines for the thermal performance of the device/pc-board system. All of the above assume no ambient airflow.		

Recommended Operating Conditions³

Symbol	Parameter	Recommended Operating Conditions			Units
		Min.	Typ.	Max.	
V _S	Supply Voltage Range		30		V
I _{PK}	Output Current (Peak)		±1		A
I _{OUT}	Output Current (Continuous)		200		mA
	Analog Inputs (Pin 2, Pin 3)	0		2.6	V
E _{AISNK}	Error Amp Output Sink Current		5		mA
OSC _{FR}	Oscillator Frequency Range	0.1		500	kHz
R _T	Oscillator Timing Resistor	0.52		150	kΩ
C _T	Oscillator Timing Capacitor	0.001		1.0	μF
Operating Ambient Temperature Range:					
	SG1844/45	-55		125	°C
	SG3844/45	0		70	°C

Note:
3. Range over which the device is functional.

Electrical Characteristics

Unless otherwise specified, these specifications apply over the operating ambient temperatures for SG1844/SG1845 with $-55^{\circ}\text{C} \leq T_A \leq 125^{\circ}\text{C}$, SG3844/SG3845 with $0^{\circ}\text{C} \leq T_A \leq 70^{\circ}\text{C}$, V_{CC} = 15V (Note 7), R_T = 10kΩ, and C_T = 3.3nF. Low duty cycle pulse testing techniques are used which maintains junction and case temperatures equal to the ambient temperature.

Symbol	Parameter	Test Conditions	SG1844/SG1845			SG3844/SG3845			Units
			Min.	Typ.	Max	Min.	Typ.	Max	
Reference Section									
V _{REF}	Output Voltage	T _J = 25°C, I _O = 1mA	4.95	5.00	5.05	4.90	5.00	5.10	V
V _{REG}	Line Regulation	12V ≤ V _{IN} ≤ 25V		6	20		6	20	mV
I _{REG}	Load Regulation	1 ≤ I _O ≤ 20mA		6	25		6	25	mV
	Temperature Stability ⁴			0.2	0.4		0.2	0.4	mV/°C
	Total Output Variation ⁴	Line, Load, Temperature	4.90		5.10	4.82		5.18	V
V _N	Output Noise Voltage ⁴	10Hz ≤ f ≤ 10kHz, T _J = 25°C		50			50		μV
	Long Term Stability ⁴	T _A = 125°C, 1000hrs		5	25		5	25	mV
V _{REFISC}	Output Short Circuit		-30	-100	-180	-30	-100	-180	mA
Oscillator Section									
f	Initial Accuracy ⁸	T _J = 25°C	47	52	57	47	52	57	kHz
f _{REG}	Voltage Stability	12V ≤ V _{CC} ≤ 25V		.02	1		0.2	1	%
	Temperature Stability ⁴	T _{MIN} ≤ T _A ≤ T _{MAX}		5			5		%
OSC _{PP}	Amplitude	V _{RT/CT} (Peak to Peak)		1.7			1.7		V
I _{DSG}	Discharge Current	T _J = 25°C	7.8	8.3	9.1	7.5	8.4	9.3	mA
		T _{MIN} ≤ T _A ≤ T _{MAX}	6.8		9.3	7.2		9.5	mA

Symbol	Parameter	Test Conditions	SG1844/SG1845			SG3844/SG3845			Units
			Min.	Typ.	Max	Min.	Typ.	Max	
Error Amplifier Section									
EA _{IH}	Input Voltage	V _{COMP} = 2.5V	2.45	2.50	2.55	2.42	2.50	2.58	V
EA _{IIB}	Input Bias Current			-0.3	-1		-0.3	-2	μA
A _{VOL}	Open Loop Gain	2V ≤ V _O ≤ 4V	65	90		65	90		dB
EA _{BW}	Unity Gain Bandwidth ⁴	T _J = 25°C	0.7	1		0.7	1		MHz
PSRR	Power Supply Rejection Ratio	12V ≤ V _{CC} ≤ 25V	60	70		60	70		dB
EA _{SNK}	Output Sink Current	V _{VFB} = 2.7V, V _{COMP} = 1.1V	2	6		2	6		mA
EA _{SRC}	Output Source Current	V _{VFB} = 2.3V, V _{COMP} = 5V	-0.5	-0.8		-0.5	-0.8		mA
EA _{VOH}	V _{OUT} High	V _{VFB} = 2.3V, R _L = 15k to GND	5	6		5	6		V
EA _{VOL}	V _{OUT} Low	V _{VFB} = 2.7V, R _L = 15k to V _{REF}		0.7	1.1		0.7	1.1	V
Current Sense Section									
CS _{AVOL}	Gain ^{5 & 6}		2.85	3	3.15	2.85	3	3.15	V/V
	Maximum Input Signal ⁵	V _{COMP} = 5V	0.9	1	1.1	0.9	1	1.1	V
PSRR	Power Supply Rejection Ratio	12V ≤ V _{CC} ≤ 25V		70			70		dB
CS _{IIB}	Input Bias Current			-2	-10		-2	-10	μA
CS _{DELAY}	Delay to Output ⁴			150	300		150	300	ns
Output Section									
VOL	Output Low Level	I _{SINK} = 20mA		0.1	0.4		0.1	0.4	V
		I _{SINK} = 200mA		1.5	2.2		1.5	2.2	V
VOH	Output High Level	I _{SOURCE} = 200mA	13	13.5		13	13.5		V
		I _{SOURCE} = 200mA	12	13.5		12	13.5		V
RS	Rise Time ⁴	T _J = 25°C, C _L = 1nF		50	150		50	150	ns
FT	Fall Time ⁴	T _J = 25°C, C _L = 1nF		50	150		50	150	ns
Under-Voltage Lockout Section									
UVLO	Start Threshold	1844	15	16	17	14.5	16	17.5	V
		1845	7.8	8.4	9.0	7.8	8.4	9.0	V
V _S MIN	Min. Operation Voltage After Turn-On	1844	9	10	11	8.5	10	11.5	V
		1845	7.0	7.6	8.3	7.0	7.6	8.2	V
PWM Section									
DC _{MAX}	Maximum Duty Cycle		46	48	50	46	48	50	%
DC _{MIN}	Minimum Duty Cycle				0			0	%
Power Consumption Section									

Symbol	Parameter	Test Conditions	SG1844/SG1845			SG3844/SG3845			Units
			Min.	Typ.	Max	Min.	Typ.	Max	
I _s	Start-Up Current			0.5	1		0.5	1	mA
I	Operating Supply Current	V _{F_{FB}} = V _{I_{SENSE}} = 0V		11	17		11	17	mA
Z	V _{CC} Zener Voltage	I _{CC} = 25mA		34			34		V

Note:

- These parameters, although guaranteed, are not 100% tested in production.
- Parameter measured at trip point of latch with V_{F_{FB}} = 0.
- Gain defined as: $A = \Delta V_{COMP} / \Delta V_{I_{SENSE}}$; $0 \leq V_{I_{SENSE}} \leq 0.8V$
- Adjust V_{CC} above the start threshold before setting at 15V.
- Output frequency equals one half of oscillator frequency.

Block Diagram

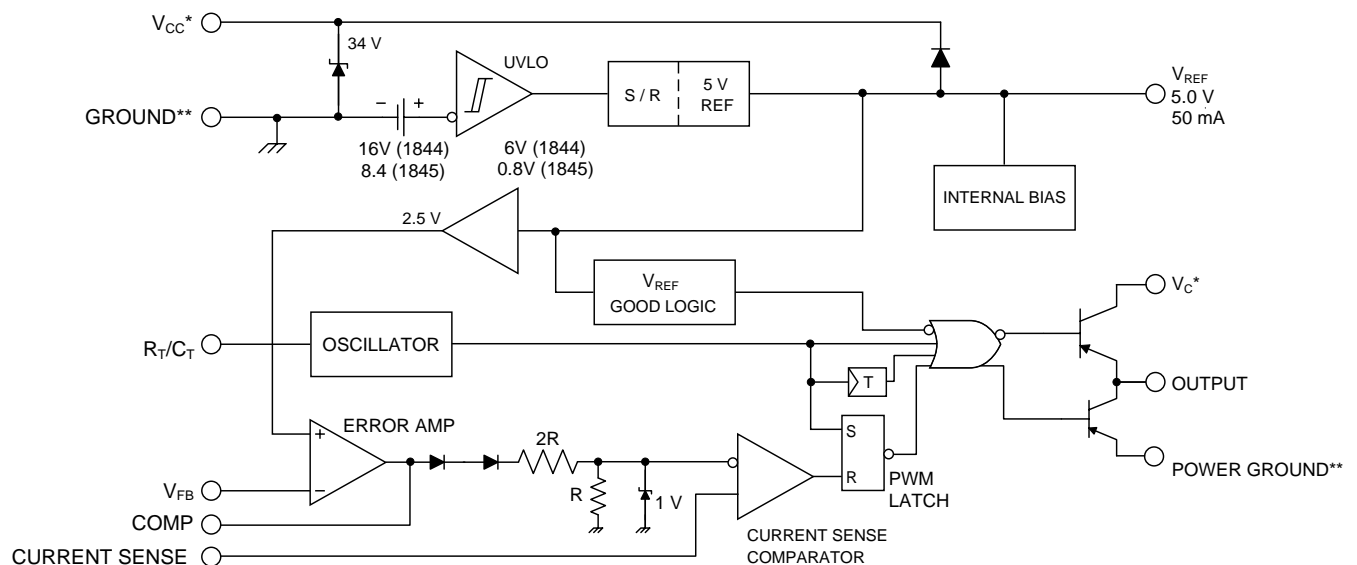

* - V_{CC} and V_C are internally connected for 8-pin packages.

** - POWER GROUND and GROUND are internally connected for 8-pin packages.

Figure 2 - Block Diagram

Characteristic Curves

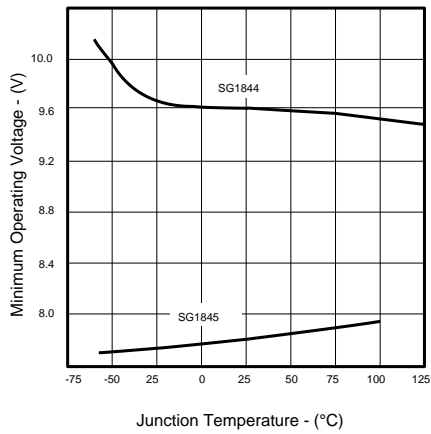

Figure 3 - Drop-out Voltage vs. Temperature

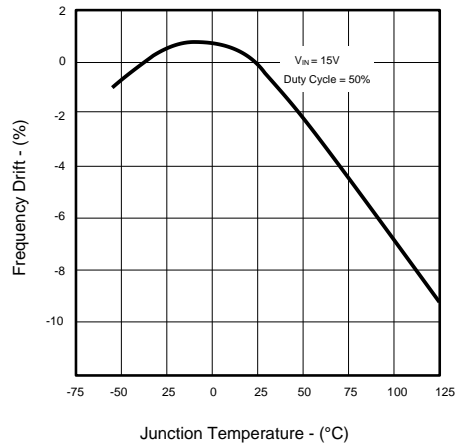

Figure 4 - Oscillator Temperature Stability

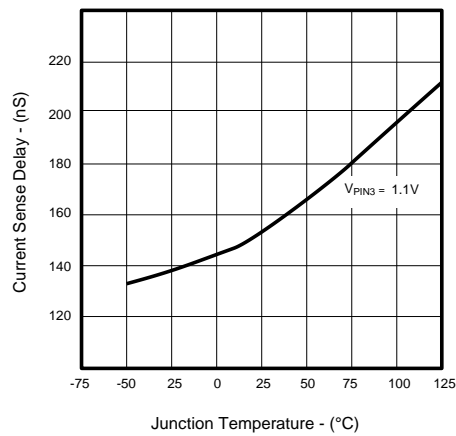

Figure 5 - Current Sense to Output Delay vs. Temperature

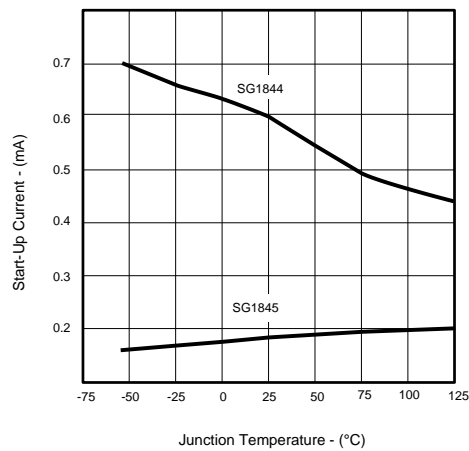

Figure 6 - Start-Up Current vs. Temperature

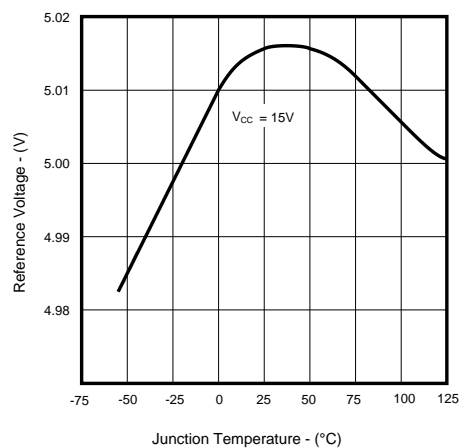

Figure 7 - Reference Voltage vs. Temperature

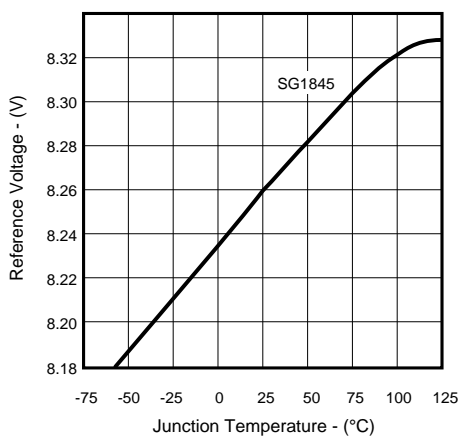

Figure 8 - Start-Up Voltage Threshold vs. Temperature

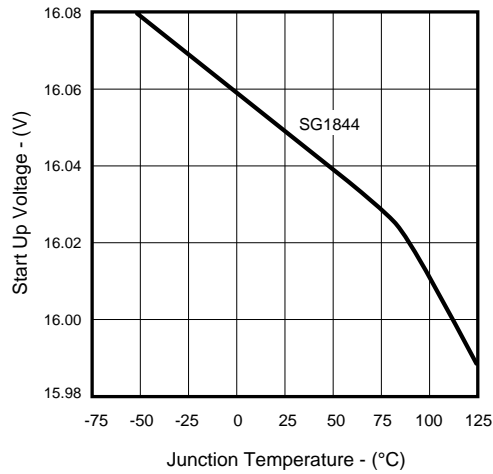

Figure 9 - Start-Up Voltage Threshold vs. Temperature

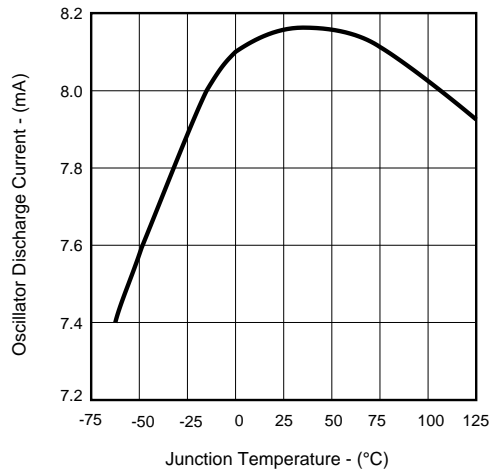

Figure 10 - Oscillator Discharge Current vs. Temperature

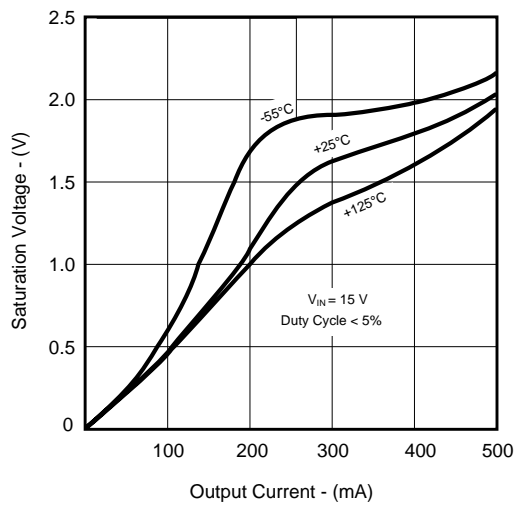

Figure 11 - Output Saturation Voltage vs. Output Current and Temperature (Sink Transistor)

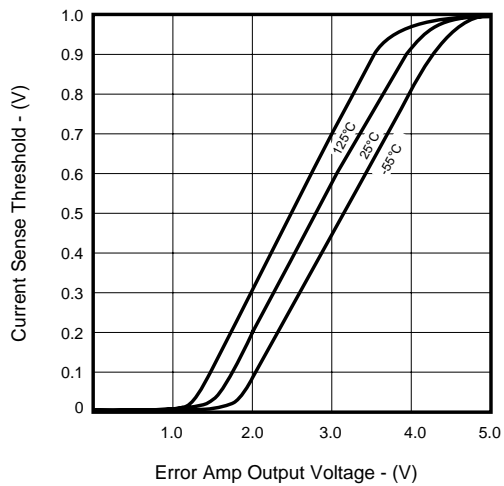

Figure 12 - Current Sense Threshold vs. Error Amplifier Output

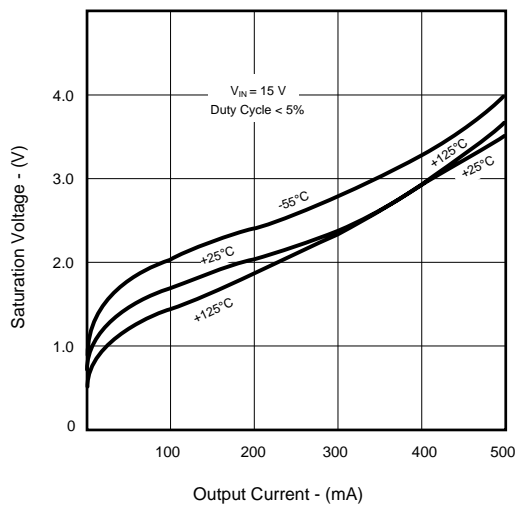

Figure 13 - Output Saturation Voltage vs. Output Current and Temperature (Source Transistor)

Application Information

The oscillator of the 1844/45 family of PWM's is programmed by the external timing components (R_T , C_T) as shown in Figure 14.

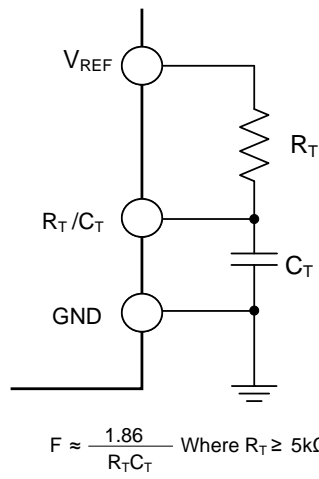

Figure 14 - Oscillator Timing Circuit

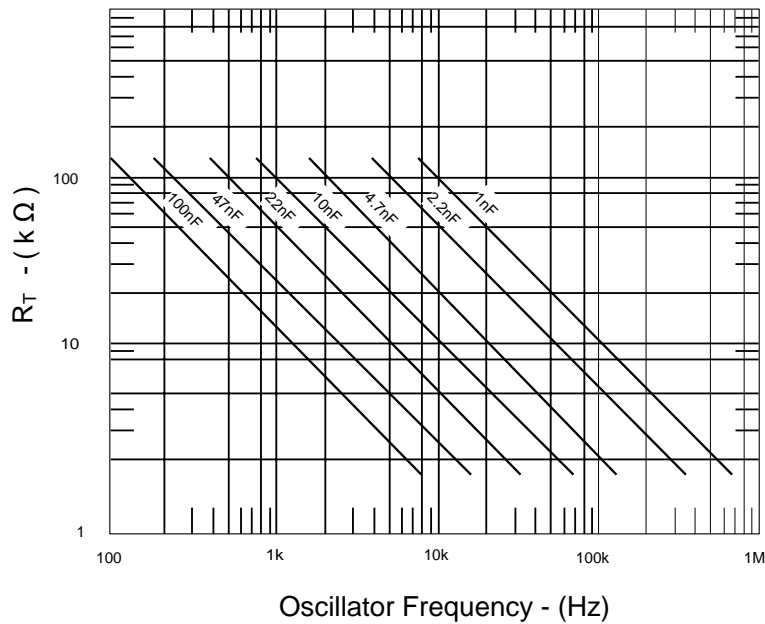

Figure 15 - Oscillator Frequency vs. R_T for various C_T

Typical Application Circuits

Pin numbers referenced are for 8-pin package and pin numbers in parenthesis are for 14-pin package.

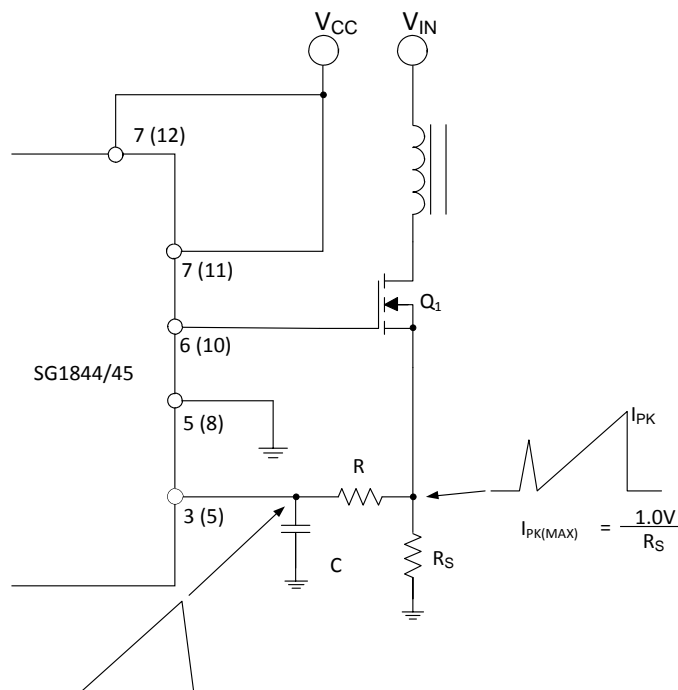

Figure 16 • Current Sense Spike Suppression

The RC low-pass filter will eliminate the leading edge current spike caused by parasitic of Power MOSFET.

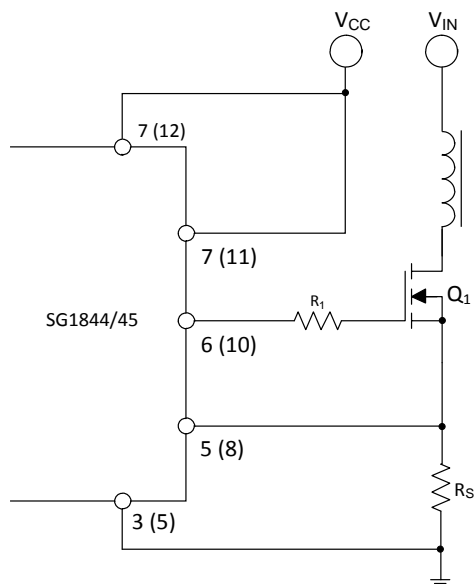

Figure 17 • MOSFET Parasitic Oscillations

A resistor (R_1) in series with the MOSFET gate reduce overshoot and ringing caused by the MOSFET input capacitance and any inductance in series with the gate drive. (Note: It is very important to have a low inductance ground path to insure correct operation of the I.C. This can be done by making the ground paths as short and as wide as possible.)

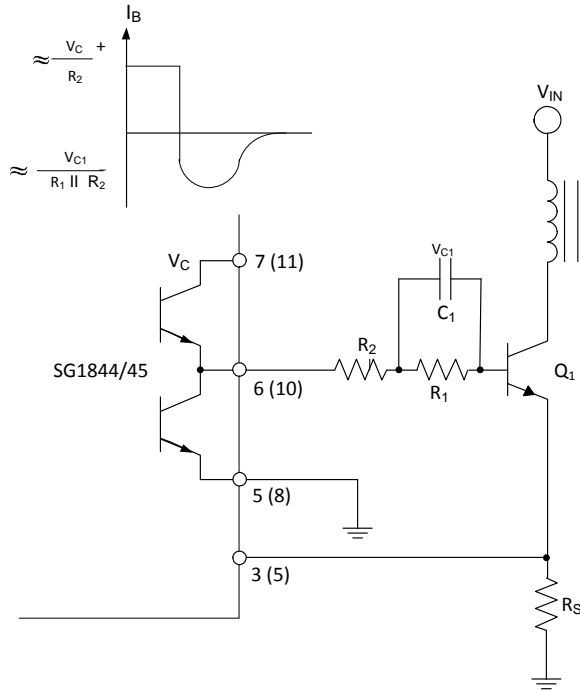

Figure 18 - Bipolar Transistor Drive

The 1844/45 output stage can provide negative base current to remove base charge of power transistor (Q_1) for faster turn off. This is accomplished by adding a capacitor (C_1) in parallel with a resistor (R_1). The resistor (R_1) is to limit the base current during turn on.

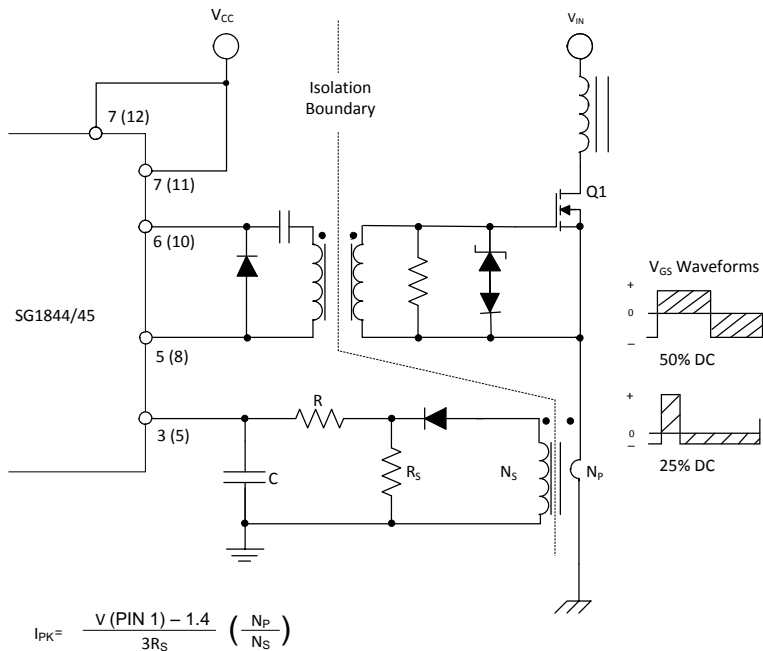
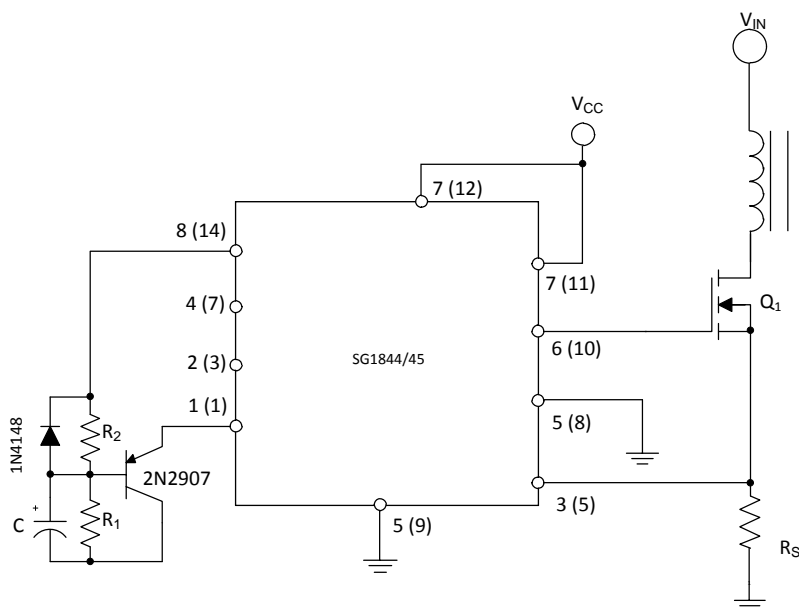

Figure 19 - Isolated MOSFET Drive

Current transformers can be used where isolation is required between PWM and Primary ground. A drive transformer is then necessary to interface the PWM output with the MOSFET.



$$I_{PK} = \frac{V_1}{R_S} \quad \text{Where, } 0 \leq V_1 \leq 1.0 \text{ V}$$

$$\text{and } V_1 = \frac{1.43 - 0.23 \frac{R_1}{R_2}}{1 + \frac{R_1}{R_2}}$$

$$t_{SOFTSTART} = -\ln\left[\frac{V_C}{R_2}\right] C \frac{R_1 R_2}{R_2 + R_2}$$

$$\text{Where, } V_2 = \frac{0.05}{1 + \frac{R_1}{R_2}}$$

Figure 20 • Adjustable Buffered Reduction of Clamp Level with Softstart

Softstart and adjustable peak current can be done with the external circuitry shown above.

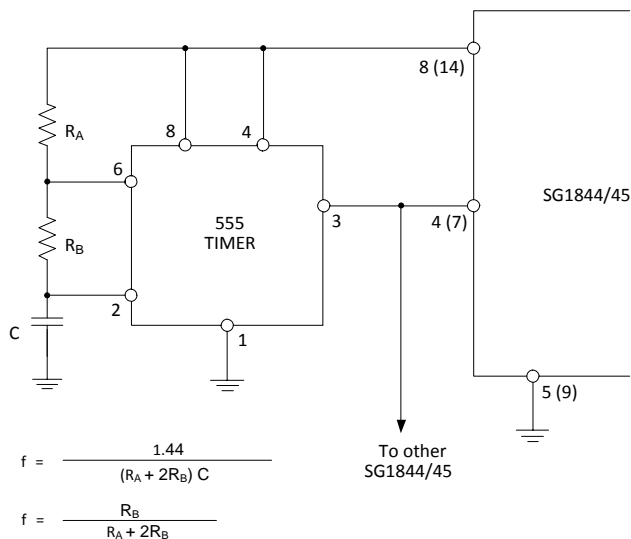

$$f = \frac{1.44}{(R_A + 2R_B) C}$$

$$f = \frac{R_B}{R_A + 2R_B}$$

Figure 21 • External Duty Cycle Clamp and Multi-Unit Synchronization

Precision duty cycle limiting for a duty cycle of <50%, as well as synchronizing several 1844/45's is possible with the above circuitry.

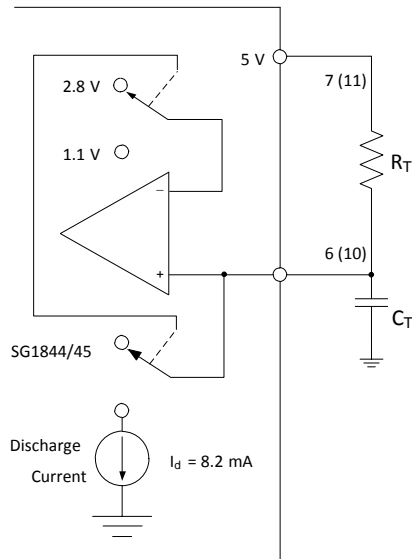

Figure 22 · Oscillator Connection

The oscillator is programmed by the values selected for the timing components R_T and C_T . Refer to application information for calculation of the component values.

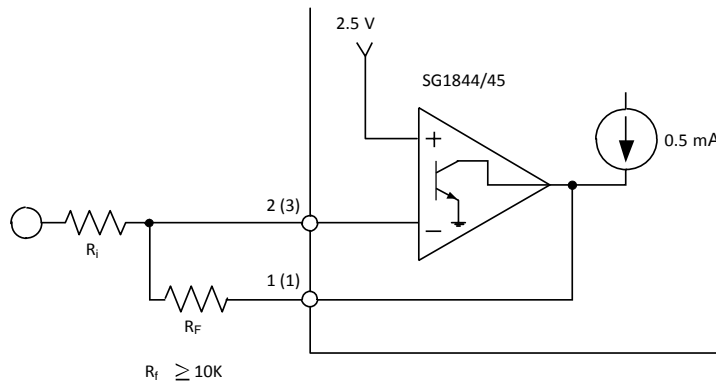
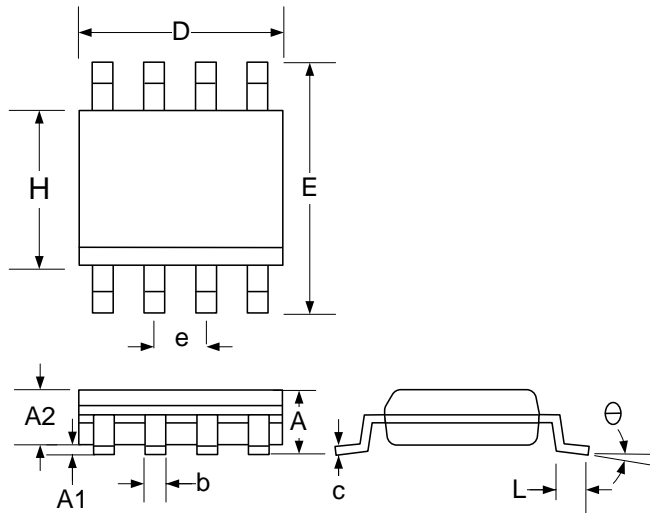

Figure 23 · Error Amplifier Connection

Error amplifier is capable of sourcing and sinking current up to 0.5mA.

PACKAGE OUTLINE DIMENSIONS

Controlling dimensions are in inches, metric equivalents are shown for general information.



Dim	MILLIMETERS		INCHES	
	MIN	MAX	MIN	MAX
A	1.35	1.75	0.053	0.069
A1	0.10	0.25	0.004	0.010
A2	1.25	1.52	0.049	0.060
b	0.33	0.51	0.013	0.020
c	0.19	0.25	0.007	0.010
D	4.83	5.21	0.189	0.205
E	5.79	6.20	0.228	0.244
e	1.27 BSC		0.050 BSC	
H	3.81	4.01	0.150	0.158
L	0.40	1.27	0.016	0.050
θ	0	8	0	8
*LC		.010		0.004

*Lead Coplanarity

Note:

- Dimensions do not include mold flash or protrusions; these shall not exceed 0.155mm (.006") on any side. Lead dimension shall not include solder coverage

Figure 24 • DM 8-Pin SOIC Package Dimensions

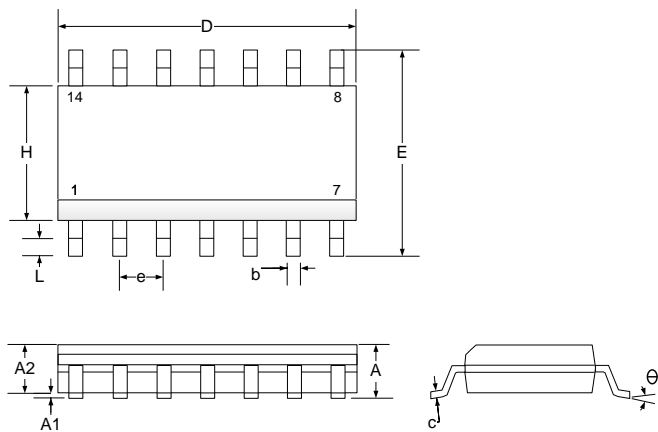

Dim	MILLIMETERS		INCHES	
	MIN	MAX	MIN	MAX
A	1.35	1.75	0.053	0.069
A1	0.10	0.25	0.004	0.010
A2	1.25	1.52	0.049	0.060
b	0.33	0.51	0.013	0.020
c	0.19	0.25	0.007	0.010
D	8.54	8.74	0.336	0.344
E	5.79	6.20	0.228	0.244
e	1.27 BSC		0.050 BSC	
H	3.81	4.01	0.150	0.158
L	0.40	1.27	0.016	0.050
θ	0	8	0	8
*LC		.010		0.004

*Lead Coplanarity

Note:

- Dimensions do not include mold flash or protrusions; these shall not exceed 0.155mm (.006") on any side. Lead dimension shall not include solder coverage

Figure 25 • D 14-Pin SOIC Package Dimensions

PACKAGE OUTLINE DIMENSIONS

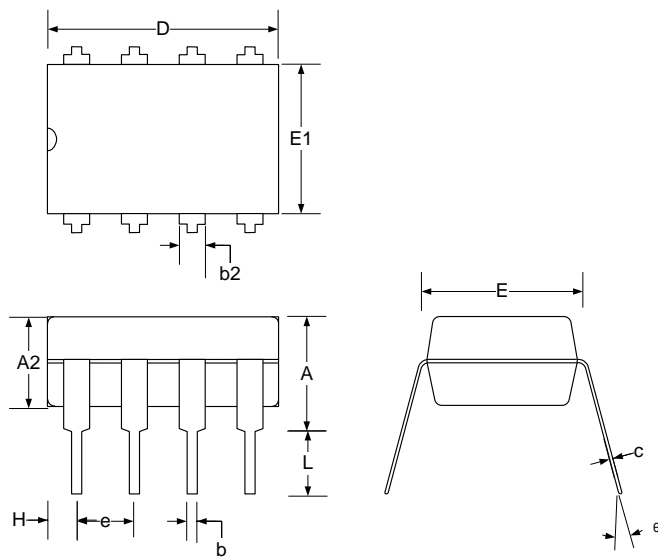

Dim	MILLIMETERS		INCHES	
	MIN	MAX	MIN	MAX
A		5.08		0.200
A2	3.30 Typ.		1.30 Typ.	
b	0.38	0.51	0.145	0.020
b2	0.76	1.65	0.030	0.065
c	0.20	0.38	0.008	0.015
D		10.16		0.400
E	7.62 BSC		0.300 BSC	
e	2.54 BSC		0.100 BSC	
E1	6.10	6.86	0.240	0.270
L	3.05		0.120	
θ	0	15	0	15

Note:

1. Dimensions do not include mold flash or protrusions; these shall not exceed 0.155mm (.006") on any side. Lead dimension shall not include solder coverage.

Figure 26 • M 8-Pin PDIP Package Dimensions

PACKAGE OUTLINE DIMENSIONS

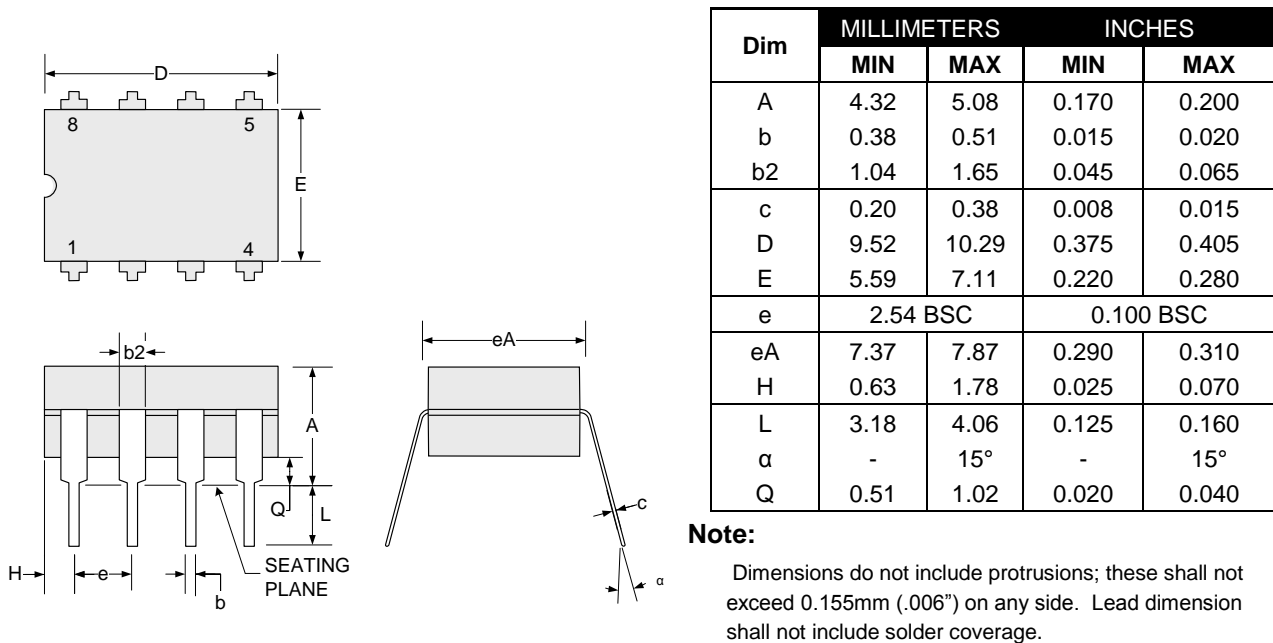

Figure 27 • Y 8-Pin Cerdip Package Dimensions

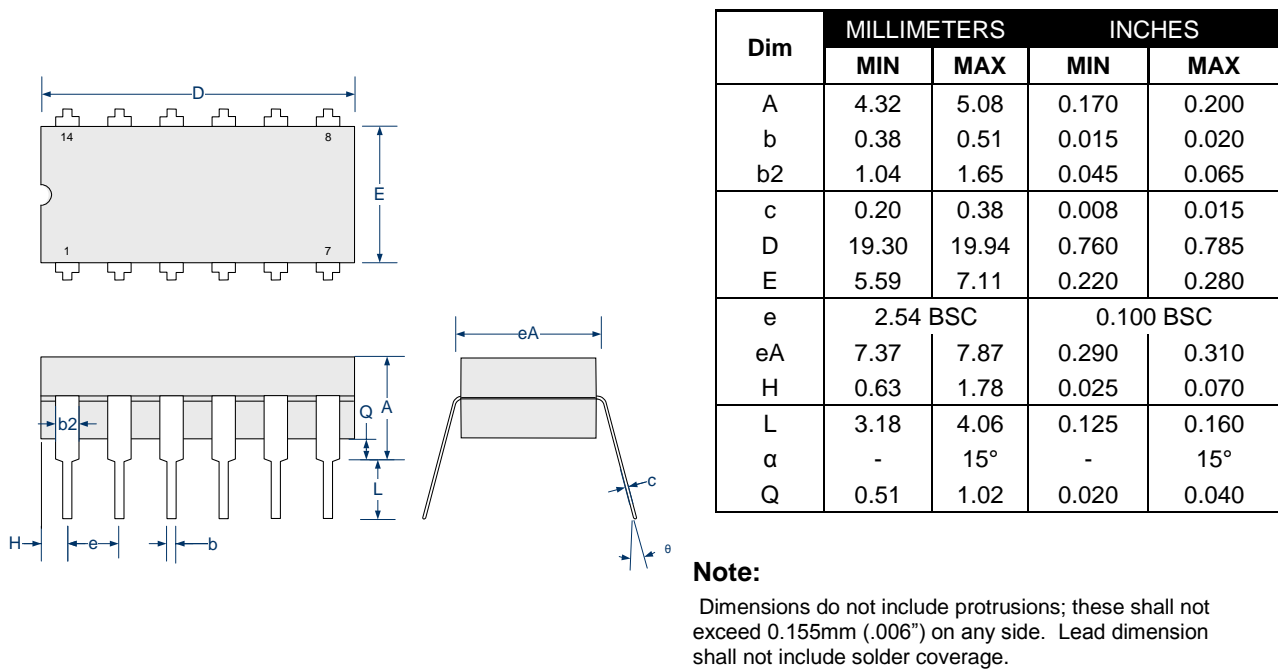
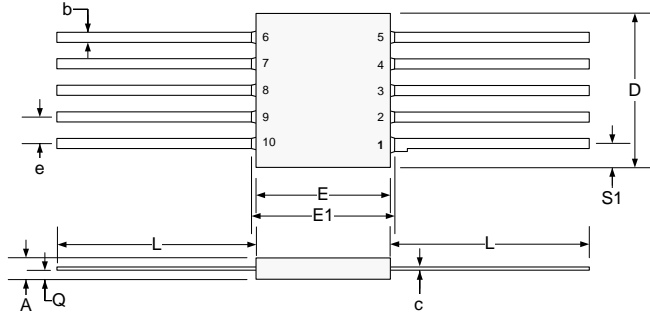

Figure 28 • J 14-Pin Cerdip Package Dimensions

PACKAGE OUTLINE DIMENSIONS



Dim	MILLIMETERS		INCHES	
	MIN	MAX	MIN	MAX
A	1.45	1.70	0.057	0.067
b	0.25	0.483	0.010	0.019
c	0.102	0.152	0.004	0.006
D	-	7.37	-	0.290
E	6.04	6.40	0.238	0.252
E1	-	6.91	-	0.272
e	1.27 BSC		0.050 BSC	
L	6.35	9.40	0.250	0.370
Q	0.51	1.02	0.020	0.040
S1	0.20	0.38	0.008	0.015

Note:

1. Lead No. 1 is identified by tab on lead or dot on cover.
2. Leads are within 0.13mm (.0005") radius of the true position (TP) at maximum material condition.
3. Dimension "e" determines a zone within which all body and lead irregularities lie.

Figure 29 - F 10-Pin Ceramic Flatpack Package Dimensions

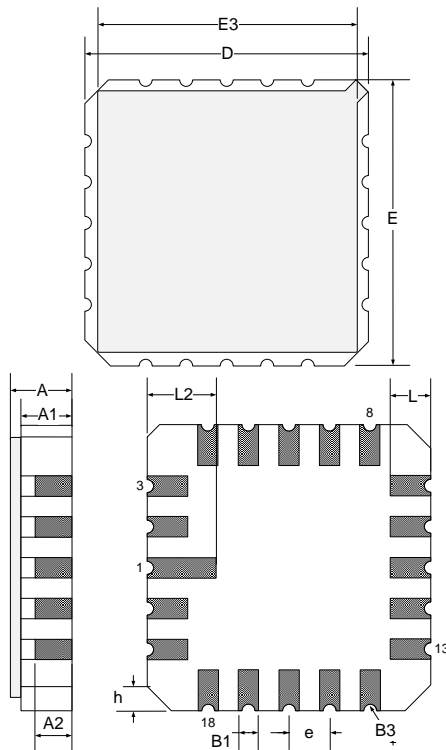

Dim	MILLIMETERS		INCHES	
	MIN	MAX	MIN	MAX
D/E	8.64	9.14	0.340	0.360
E3	-	8.128	-	0.320
e	1.270 BSC		0.050 BSC	
B1	0.635 TYP		0.025 TYP	
L	1.02	1.52	0.040	0.060
A	1.626	2.286	0.064	0.090
h	1.016 TYP		0.040 TYP	
A1	1.372	1.68	0.054	0.066
A2	-	1.168	-	0.046
L2	1.91	2.41	0.075	0.95
B3	0.203R		0.008R	

Note:

All exposed metalized area shall be gold plated 60 micro-inch minimum thickness over nickel plated unless otherwise specified in purchase order.

Figure 30 - L 20-Pin Leadless Chip Carrier Package Dimensions



Microsemi Corporate Headquarters
One Enterprise, Aliso Viejo,
CA 92656 USA

Within the USA: +1 (800) 713-4113
Outside the USA: +1 (949) 380-6100
Sales: +1 (949) 380-6136
Fax: +1 (949) 215-4996

E-mail: sales.support@microsemi.com

© 2014 Microsemi Corporation. All rights reserved. Microsemi and the Microsemi logo are trademarks of Microsemi Corporation. All other trademarks and service marks are the property of their respective owners.

Microsemi Corporation (Nasdaq: MSCC) offers a comprehensive portfolio of semiconductor and system solutions for communications, defense & security, aerospace and industrial markets. Products include high-performance and radiation-hardened analog mixed-signal integrated circuits, FPGAs, SoCs and ASICs; power management products; timing and synchronization devices and precise time solutions, setting the world's standard for time; voice processing devices; RF solutions; discrete components; security technologies and scalable anti-tamper products; Power-over-Ethernet ICs and midspans; as well as custom design capabilities and services. Microsemi is headquartered in Aliso Viejo, Calif., and has approximately 3,400 employees globally. Learn more at www.microsemi.com.

Microsemi makes no warranty, representation, or guarantee regarding the information contained herein or the suitability of its products and services for any particular purpose, nor does Microsemi assume any liability whatsoever arising out of the application or use of any product or circuit. The products sold hereunder and any other products sold by Microsemi have been subject to limited testing and should not be used in conjunction with mission-critical equipment or applications. Any performance specifications are believed to be reliable but are not verified, and Buyer must conduct and complete all performance and other testing of the products, alone and together with, or installed in, any end-products. Buyer shall not rely on any data and performance specifications or parameters provided by Microsemi. It is the Buyer's responsibility to independently determine suitability of any products and to test and verify the same. The information provided by Microsemi hereunder is provided "as is, where is" and with all faults, and the entire risk associated with such information is entirely with the Buyer. Microsemi does not grant, explicitly or implicitly, to any party any patent rights, licenses, or any other IP rights, whether with regard to such information itself or anything described by such information. Information provided in this document is proprietary to Microsemi, and Microsemi reserves the right to make any changes to the information in this

Looking for pricing, stock, or lifecycle information?

Click below to explore more details on WIN SOURCE:

- ⊖ [View SG1845Y on WIN SOURCE](#)
- ⊖ [Microsemi Corporation Information](#)

Optimize Your Supply Chain with WIN SOURCE Solutions

- ✓ Global Sourcing Solution
- ✓ Obsolete Management
- ✓ Cost Control Management
- ✓ Shortage Management
- ✓ Alternative Solution
- ✓ Excess Inventory Management