



THE DATASHEET OF MRFG35010



MRFG35010R1 replaced by MRFG35010AR1.

MRFG35010R1

Gallium Arsenide PHEMT
RF Power Field Effect Transistor

Designed for WLL/MMDS or UMTS driver applications with frequencies from 1800 to 3600 MHz. Device is unmatched and is suitable for use in Class AB or Class A linear base station applications.

- Typical W-CDMA Performance: -42 dBc ACPR, 3.55 GHz, 12 Volts, $I_{DQ} = 180$ mA, 5 MHz Offset/3.84 MHz BW, 64 DPCH (8.5 dB P/A @ 0.01% Probability)
 Output Power — 1 Watt
 Power Gain — 10 dB
 Efficiency — 30%
- 10 Watts P1dB @ 3550 MHz
- Excellent Phase Linearity and Group Delay Characteristics
- High Gain, High Efficiency and High Linearity
- RoHS Compliant
- In Tape and Reel. R1 Suffix = 500 Units per 32 mm, 13 inch Reel.

3.5 GHz, 10 W, 12 V
POWER FET
GaAs PHEMT

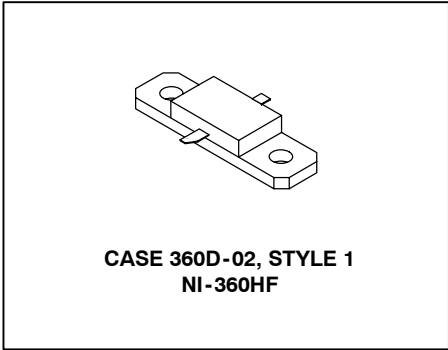

ARCHIVE INFORMATION

ARCHIVE INFORMATION

Table 1. Maximum Ratings

Rating	Symbol	Value	Unit
Drain-Source Voltage	V_{DSS}	15	Vdc
Total Device Dissipation @ $T_C = 25^\circ\text{C}$ Derate above 25°C	P_D	28.3 0.19	W W/ $^\circ\text{C}$
Gate-Source Voltage	V_{GS}	-5	Vdc
RF Input Power	P_{in}	33	dBm
Storage Temperature Range	T_{stg}	-65 to +175	$^\circ\text{C}$
Channel Temperature (1)	T_{ch}	175	$^\circ\text{C}$
Operating Case Temperature Range	T_C	-20 to +90	$^\circ\text{C}$

Table 2. Thermal Characteristics

Characteristic	Symbol	Value	Unit
Thermal Resistance, Junction to Case Class A Class AB	$R_{\theta JC}$	5.3 4.8	$^\circ\text{C}/\text{W}$

1. For reliable operation, the operating channel temperature should not exceed 150°C .

Table 3. Electrical Characteristics ($T_C = 25^\circ\text{C}$ unless otherwise noted)

Characteristic	Symbol	Min	Typ	Max	Unit
Saturated Drain Current ($V_{DS} = 3.5 \text{ Vdc}$, $V_{GS} = 0 \text{ Vdc}$)	I_{DSS}	—	2.9	—	Adc
Off State Leakage Current ($V_{GS} = -0.4 \text{ Vdc}$, $V_{DS} = 0 \text{ Vdc}$)	I_{GSS}	—	< 1	100	μAdc
Off State Drain Current ($V_{DS} = 12 \text{ Vdc}$, $V_{GS} = -1.9 \text{ Vdc}$)	I_{DSO}	—	0.09	1	mAdc
Off State Current ($V_{DS} = 28.5 \text{ Vdc}$, $V_{GS} = -2.5 \text{ Vdc}$)	I_{DSX}	—	5	15	mAdc
Gate-Source Cut-off Voltage ($V_{DS} = 3.5 \text{ Vdc}$, $I_{DS} = 15 \text{ mA}$)	$V_{GS(th)}$	-1.2	-0.8	-0.7	Vdc
Quiescent Gate Voltage ($V_{DS} = 12 \text{ Vdc}$, $I_D = 180 \text{ mA}$)	$V_{GS(Q)}$	-1	-0.8	-0.5	Vdc
Power Gain ($V_{DD} = 12 \text{ Vdc}$, $I_{DQ} = 180 \text{ mA}$, $f = 3.55 \text{ GHz}$)	G_{ps}	9	10	—	dB
Output Power, 1 dB Compression Point ($V_{DD} = 12 \text{ Vdc}$, $I_{DQ} = 180 \text{ mA}$, $f = 3.55 \text{ GHz}$)	P_{1dB}	—	10	—	W
Drain Efficiency ($V_{DD} = 12 \text{ Vdc}$, $I_{DQ} = 180 \text{ mA}$, $P_{out} = 1 \text{ W Avg.}$, $f = 3.55 \text{ GHz}$)	η_D	23	30	—	%
Adjacent Channel Power Ratio ($V_{DD} = 12 \text{ Vdc}$, $P_{out} = 1 \text{ W Avg.}$, $I_{DQ} = 180 \text{ mA}$, $f = 3.55 \text{ GHz}$, W-CDMA, 8.5 P/A @ 0.01% Probability, 64 CH, 3.84 MCPS)	ACPR	—	-42	-40	dBc

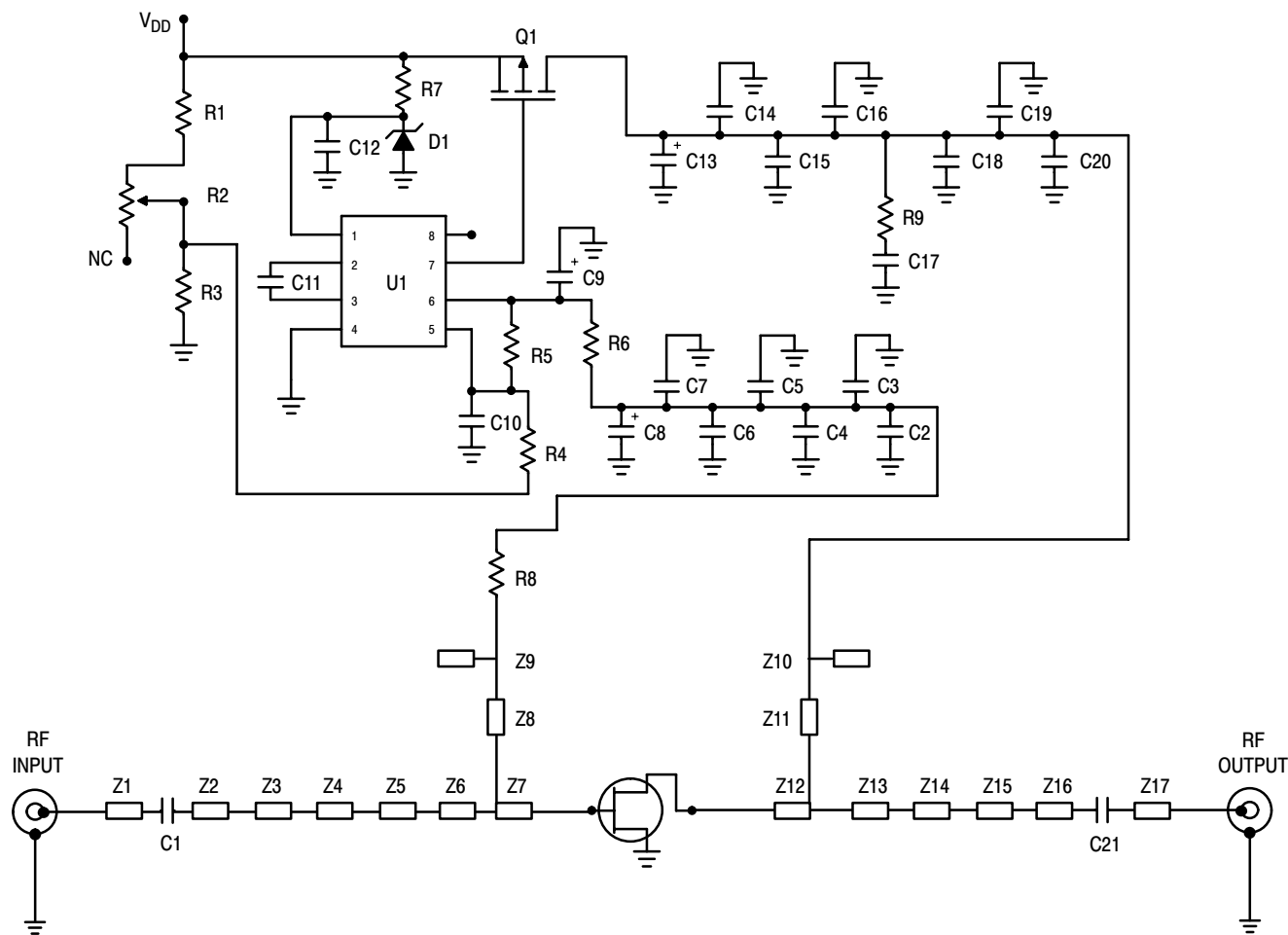

C1, C21	6.8 pF Chip Capacitors, ATC	U1	Voltage Converter, LTC 1261
C2, C20	10 pF Chip Capacitors, ATC	Q1	Switch, MTP23P06V
C3, C19	100 pF Chip Capacitors, ATC	PCB	Rogers RO4350, 0.020", $\epsilon_r = 3.50$
C4, C18	100 pF Chip Capacitors, ATC	Z1	0.044" x 0.250" Microstrip
C5, C10, C16, C17	1000 pF Chip Capacitors, ATC	Z2	0.044" x 0.030" Microstrip
C6, C11, C12, C15	0.1 μ F Chip Capacitors, ATC	Z3	0.615" x 0.050" Microstrip
C7, C14	39K Chip Capacitors, ATC	Z4	0.044" x 0.070" Microstrip
C8, C13	22 μ F Tantalum Chip Capacitors	Z5	0.270" x 0.490" Microstrip
C9	6.8 μ F Tantalum Chip Capacitor	Z6	0.044" x 0.470" Microstrip
D1	5.1 V Zener Diode, MA8051CT-ND	Z7	0.434" x 0.110" Microstrip
R1	22.1 k Ω , 1/4 W 1%, Chip Resistor	Z8, Z11	0.015" x 0.527" Microstrip
R2	5K Trim Pot, #3224W-1-502E	Z9, Z10	0.290" x 90° Microstrip Radial Stub
R3	12 k Ω , 1/4 W 1%, Chip Resistor	Z12	0.184" x 0.390" Microstrip
R4	100 k Ω , 1/4 W 1%, Chip Resistor	Z13	0.040" x 0.580" Microstrip
R5	39 k Ω , 1/4 W 1%, Chip Resistor	Z14	0.109" x 0.099" Microstrip
R6	10 Ω , 1/4 W 1%, Chip Resistor	Z15	0.030" x 0.225" Microstrip
R7	2.2 k Ω , 1/4 W 1%, Chip Resistor	Z16	0.080" x 0.240" Microstrip
R8, R9	50 Ω , 1/4 W 1%, Chip Resistors	Z17	0.044" x 0.143" Microstrip

Figure 1. 3.4 - 3.6 GHz Single Supply Bias Sequencing Test Circuit Schematic

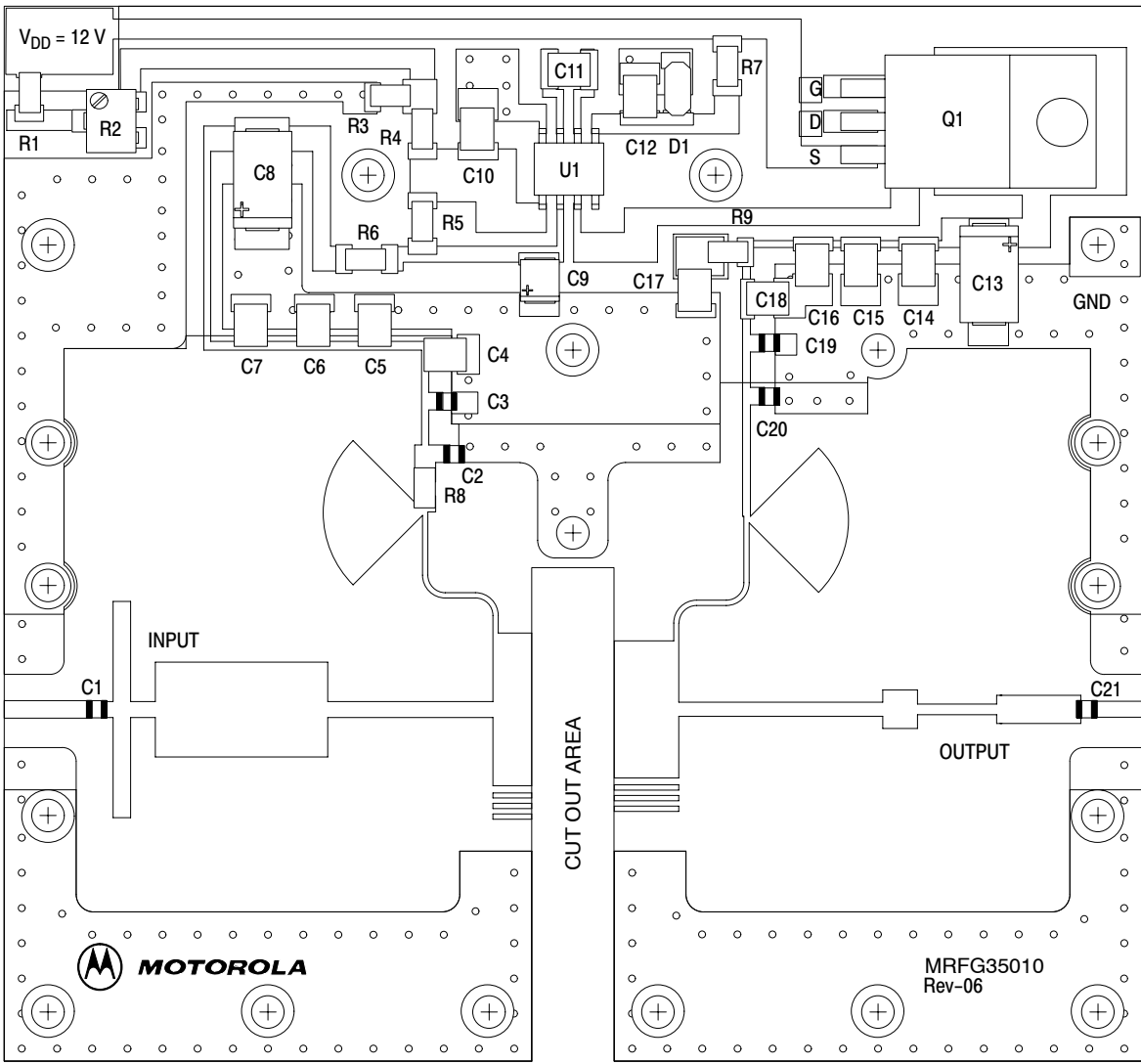

Freescle has begun the transition of marking Printed Circuit Boards (PCBs) with the Freescle Semiconductor signature/logo. PCBs may have either Motorola or Freescle markings during the transition period. These changes will have no impact on form, fit or function of the current product.

Figure 2. 3.4 - 3.6 GHz Test Circuit Component Layout

TYPICAL CHARACTERISTICS

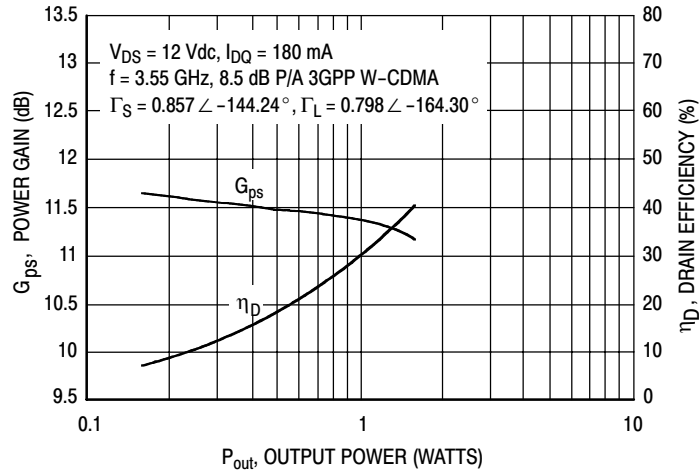

Figure 3. Power Gain and Drain Efficiency versus Output Power

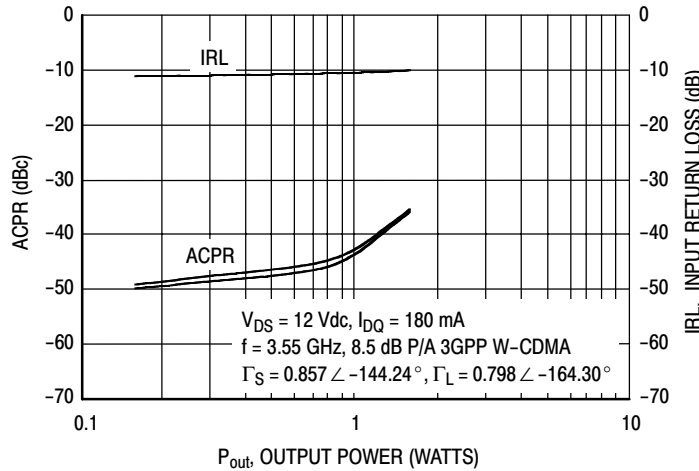

Figure 4. W-CDMA ACPR and Input Return Loss versus Output Power

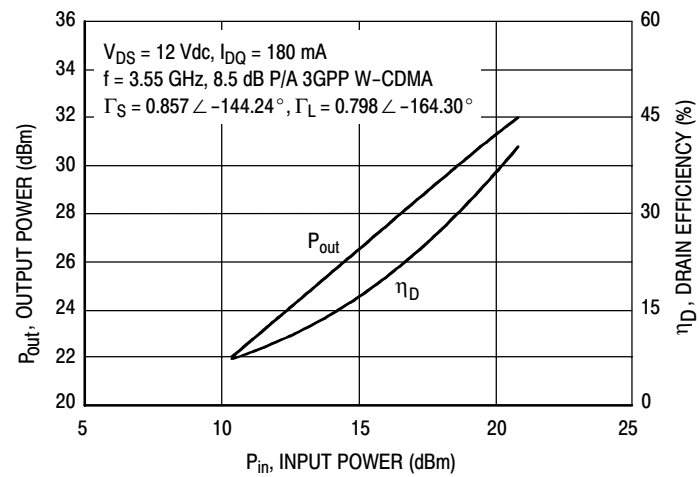
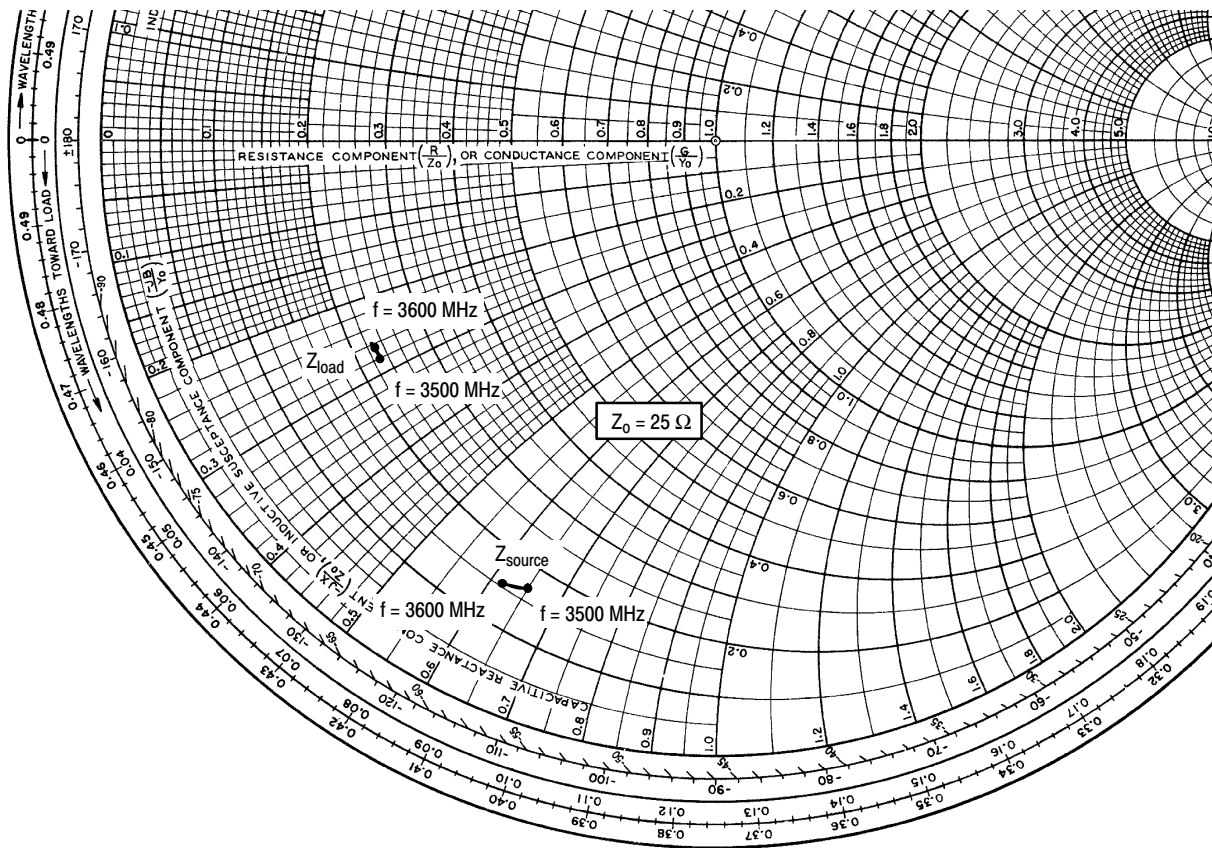

Figure 5. W-CDMA Output Power and Drain Efficiency versus Input Power

NOTE: All data is referenced to package lead interface. Γ_S and Γ_L are the impedances presented to the DUT. All data is generated from load pull, not from the test circuit shown.



$V_{DD} = 12\text{ V}$, $I_{DQ} = 180\text{ mA}$, $P_{out} = 1\text{ W}$

f MHz	Z_{source} Ω	Z_{load} Ω
3500	$4.3 - j16.3$	$5.7 - j7.0$
3550	$4.2 - j16.0$	$5.7 - j6.8$
3600	$4.1 - j15.8$	$5.7 - j6.6$

Z_{source} = Test circuit impedance as measured from gate to ground.

Z_{load} = Test circuit impedance as measured from drain to ground.

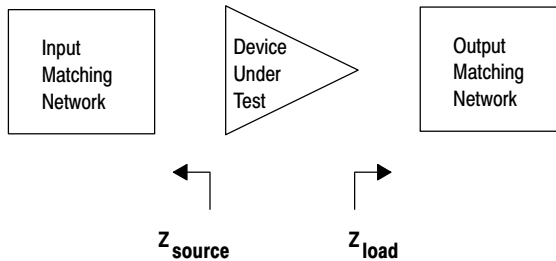

Figure 6. Series Equivalent Source and Load Impedance

Table 4. Class A Common Source S-Parameters at $V_{DS} = 12$ Vdc, $I_{DQ} = 1000$ mA

f GHz	S ₁₁		S ₂₁		S ₁₂		S ₂₂	
	S ₁₁	∠φ	S ₂₁	∠φ	S ₁₂	∠φ	S ₂₂	∠φ
0.50	0.956	-177.95	5.591	79.60	0.007	15.64	0.741	179.71
0.60	0.957	-179.86	4.668	76.30	0.007	23.81	0.739	179.15
0.70	0.956	178.44	4.007	73.21	0.008	23.84	0.736	178.75
0.80	0.956	177.05	3.520	70.18	0.008	26.09	0.736	178.29
0.90	0.954	175.83	3.138	67.20	0.009	30.55	0.735	177.85
1.00	0.955	174.61	2.842	64.30	0.010	28.91	0.735	177.42
1.10	0.954	173.42	2.604	61.65	0.009	31.64	0.734	176.95
1.20	0.952	172.29	2.402	58.87	0.011	31.90	0.735	176.52
1.30	0.952	171.25	2.236	56.13	0.011	36.06	0.735	175.97
1.40	0.950	170.02	2.098	53.34	0.011	33.99	0.736	175.52
1.50	0.950	168.36	2.054	50.41	0.011	32.65	0.725	174.86
1.60	0.948	167.24	1.944	47.63	0.012	32.47	0.725	174.31
1.70	0.946	166.01	1.850	44.77	0.013	37.07	0.725	173.70
1.80	0.944	164.67	1.769	42.06	0.014	34.40	0.725	172.90
1.90	0.943	163.59	1.698	39.29	0.015	35.71	0.725	172.32
2.00	0.942	162.31	1.638	36.53	0.015	37.47	0.724	171.58
2.10	0.940	161.09	1.580	33.69	0.016	35.82	0.724	170.75
2.20	0.938	159.66	1.532	30.84	0.017	35.69	0.722	169.89
2.30	0.937	158.30	1.491	28.03	0.017	35.43	0.721	169.04
2.40	0.935	156.86	1.454	25.19	0.019	34.19	0.720	168.15
2.50	0.934	155.35	1.422	22.38	0.020	34.10	0.718	167.32
2.60	0.932	153.83	1.396	19.54	0.021	35.51	0.718	166.38
2.70	0.928	152.26	1.375	16.68	0.022	33.15	0.716	165.61
2.80	0.926	150.58	1.356	13.80	0.023	30.84	0.714	164.67
2.90	0.923	148.97	1.342	10.91	0.025	31.00	0.711	163.77
3.00	0.920	147.18	1.332	7.87	0.027	29.11	0.708	162.89
3.10	0.917	145.27	1.328	4.88	0.028	28.98	0.704	161.96
3.20	0.913	143.23	1.326	1.73	0.030	27.36	0.699	161.08
3.30	0.908	141.12	1.329	-1.48	0.032	25.93	0.694	160.09
3.40	0.903	138.91	1.335	-4.80	0.034	24.33	0.687	159.09
3.50	0.897	136.46	1.346	-8.26	0.036	22.30	0.679	158.02
3.60	0.893	133.77	1.360	-11.89	0.039	19.80	0.670	156.93
3.70	0.884	130.86	1.375	-15.61	0.042	17.46	0.659	155.90
3.80	0.875	127.58	1.393	-19.50	0.045	15.22	0.648	154.96
3.90	0.866	124.06	1.417	-23.55	0.048	13.31	0.636	154.06
4.00	0.851	120.13	1.443	-27.75	0.052	10.27	0.626	153.16
4.10	0.833	115.98	1.472	-32.06	0.056	7.36	0.618	152.14
4.20	0.814	111.48	1.505	-36.63	0.060	4.18	0.609	151.13
4.30	0.793	106.69	1.541	-41.44	0.065	1.13	0.602	149.84
4.40	0.771	101.44	1.581	-46.57	0.071	-3.19	0.592	148.47
4.50	0.748	95.69	1.622	-51.82	0.076	-7.50	0.582	147.06
4.60	0.723	89.38	1.668	-57.33	0.082	-11.79	0.575	145.72
4.70	0.697	82.41	1.721	-63.32	0.089	-16.57	0.568	144.03
4.80	0.672	74.51	1.771	-69.70	0.096	-22.28	0.559	142.02
4.90	0.647	65.82	1.818	-76.56	0.103	-28.04	0.549	139.82
5.00	0.622	56.14	1.860	-83.67	0.110	-33.91	0.539	137.39

ARCHIVE INFORMATION

ARCHIVE INFORMATION

Table 5. Class AB Common Source S-Parameters at $V_{DS} = 12$ Vdc, $I_{DQ} = 180$ mA

f GHz	S ₁₁		S ₂₁		S ₁₂		S ₂₂	
	S ₁₁	∠ φ	S ₂₁	∠ φ	S ₁₂	∠ φ	S ₂₂	∠ φ
0.50	0.936	-175.05	5.292	80.70	0.014	3.73	0.735	-178.66
0.60	0.936	-177.28	4.422	77.20	0.014	3.63	0.735	-179.61
0.70	0.935	-179.21	3.803	74.02	0.015	3.78	0.735	179.80
0.80	0.935	179.21	3.341	70.87	0.014	7.22	0.736	179.20
0.90	0.935	177.77	2.983	67.85	0.014	5.83	0.738	178.58
1.00	0.934	176.46	2.701	64.80	0.015	7.03	0.738	178.09
1.10	0.934	175.26	2.473	62.00	0.015	7.15	0.738	177.54
1.20	0.933	174.05	2.284	59.24	0.014	6.85	0.739	177.01
1.30	0.933	172.86	2.124	56.47	0.015	6.90	0.740	176.42
1.40	0.933	171.71	1.991	53.70	0.015	8.93	0.739	175.92
1.50	0.929	170.06	1.948	50.73	0.016	7.81	0.730	175.22
1.60	0.930	168.89	1.845	47.88	0.016	8.58	0.731	174.51
1.70	0.927	167.73	1.757	44.99	0.016	8.16	0.731	173.88
1.80	0.926	166.37	1.678	42.32	0.016	10.00	0.730	173.09
1.90	0.925	165.33	1.610	39.48	0.017	9.25	0.732	172.45
2.00	0.923	164.05	1.551	36.70	0.018	11.89	0.731	171.71
2.10	0.921	162.82	1.498	33.90	0.018	10.06	0.731	170.85
2.20	0.920	161.49	1.451	31.07	0.018	10.11	0.730	170.01
2.30	0.918	160.17	1.411	28.22	0.019	10.86	0.729	169.14
2.40	0.916	158.74	1.376	25.43	0.020	9.05	0.728	168.25
2.50	0.916	157.35	1.347	22.58	0.020	8.57	0.727	167.43
2.60	0.913	155.97	1.321	19.80	0.021	9.64	0.727	166.51
2.70	0.912	154.45	1.300	16.98	0.022	10.23	0.725	165.61
2.80	0.909	152.83	1.280	14.05	0.023	9.68	0.723	164.76
2.90	0.907	151.25	1.268	11.14	0.024	10.24	0.719	163.70
3.00	0.904	149.54	1.257	8.18	0.026	7.35	0.717	162.83
3.10	0.901	147.76	1.253	5.20	0.026	9.11	0.714	161.86
3.20	0.896	145.88	1.253	2.11	0.028	6.33	0.709	160.85
3.30	0.893	143.83	1.255	-1.10	0.030	7.09	0.704	159.82
3.40	0.887	141.78	1.260	-4.43	0.031	5.16	0.697	158.76
3.50	0.882	139.43	1.268	-7.81	0.033	4.74	0.690	157.60
3.60	0.876	136.99	1.281	-11.29	0.035	4.34	0.682	156.46
3.70	0.870	134.24	1.295	-14.96	0.038	1.64	0.672	155.26
3.80	0.863	131.29	1.311	-18.72	0.040	0.43	0.660	154.16
3.90	0.853	127.96	1.334	-22.68	0.042	-2.33	0.650	153.12
4.00	0.840	124.33	1.354	-26.85	0.046	-4.01	0.639	152.16
4.10	0.825	120.40	1.386	-31.01	0.049	-6.67	0.632	150.97
4.20	0.807	116.26	1.414	-35.40	0.053	-9.06	0.624	149.72
4.30	0.787	111.78	1.453	-40.01	0.057	-11.29	0.617	148.33
4.40	0.767	106.97	1.492	-44.83	0.061	-14.79	0.608	146.78
4.50	0.745	101.74	1.537	-49.99	0.066	-18.66	0.599	145.00
4.60	0.721	95.90	1.579	-55.50	0.071	-22.20	0.589	143.33
4.70	0.697	89.39	1.633	-61.25	0.077	-26.02	0.580	141.41
4.80	0.674	82.09	1.685	-67.46	0.084	-30.63	0.569	139.21
4.90	0.647	73.93	1.740	-74.01	0.090	-35.78	0.557	136.94
5.00	0.622	64.84	1.790	-81.02	0.097	-41.70	0.545	134.20

ARCHIVE INFORMATION

ARCHIVE INFORMATION

PACKAGE DIMENSIONS

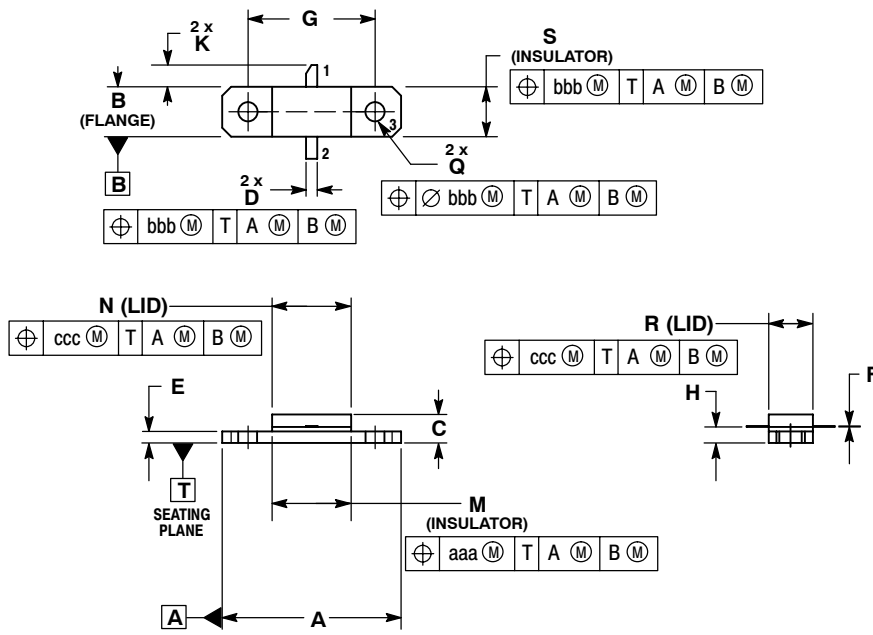

- NOTES:
1. CONTROLLING DIMENSION: INCH.
 2. INTERPRET DIMENSIONS AND TOLERANCES PER ASME Y14.5M-1994.
 3. DIMENSION H IS MEASURED .030 (0.762) AWAY FROM PACKAGE BODY.

DIM	INCHES		MILLIMETERS	
	MIN	MAX	MIN	MAX
A	.795	.805	20.19	20.45
B	.225	.235	5.72	5.97
C	.125	.176	3.18	4.47
D	.034	.044	0.89	1.12
E	.055	.065	1.40	1.65
F	.004	.006	0.10	0.15
G	.562 BSC		14.28 BSC	
H	.077	.087	1.96	2.21
K	.085	.115	2.16	2.92
M	.355	.365	9.02	9.27
N	.355	.365	9.96	10.16
Q	.125	.135	3.18	3.43
R	.225	.235	5.72	5.97
S	.225	.235	5.72	5.97
aaa	.005		0.13	
bbb	.010		0.25	
ccc	.015		0.38	

- STYLE 1:
- PIN 1. GATE
 - PIN 2. DRAIN
 - PIN 3. SOURCE

CASE 360D-02
ISSUE C
NI-360HF

REVISION HISTORY

The following table summarizes revisions to this document.

Revision	Date	Description
9	Jan. 2008	<ul style="list-style-type: none">Listed replacement part, p. 1Added Revision History, p. 10

How to Reach Us:

Home Page:

www.freescale.com

Web Support:

<http://www.freescale.com/support>

USA/Europe or Locations Not Listed:

Freescale Semiconductor, Inc.
 Technical Information Center, EL516
 2100 East Elliot Road
 Tempe, Arizona 85284
 +1-800-521-6274 or +1-480-768-2130
www.freescale.com/support

Europe, Middle East, and Africa:

Freescale Halbleiter Deutschland GmbH
 Technical Information Center
 Schatzbogen 7
 81829 Muenchen, Germany
 +44 1296 380 456 (English)
 +46 8 52200080 (English)
 +49 89 92103 559 (German)
 +33 1 69 35 48 48 (French)
www.freescale.com/support

Japan:

Freescale Semiconductor Japan Ltd.
 Headquarters
 ARCO Tower 15F
 1-8-1, Shimo-Meguro, Meguro-ku,
 Tokyo 153-0064
 Japan
 0120 191014 or +81 3 5437 9125
support.japan@freescale.com

Asia/Pacific:

Freescale Semiconductor Hong Kong Ltd.
 Technical Information Center
 2 Dai King Street
 Tai Po Industrial Estate
 Tai Po, N.T., Hong Kong
 +800 2666 8080
support.asia@freescale.com

For Literature Requests Only:

Freescale Semiconductor Literature Distribution Center
 P.O. Box 5405
 Denver, Colorado 80217
 1-800-441-2447 or 303-675-2140
 Fax: 303-675-2150
LDCForFreescaleSemiconductor@hibbertgroup.com

Information in this document is provided solely to enable system and software implementers to use Freescale Semiconductor products. There are no express or implied copyright licenses granted hereunder to design or fabricate any integrated circuits or integrated circuits based on the information in this document.

Freescale Semiconductor reserves the right to make changes without further notice to any products herein. Freescale Semiconductor makes no warranty, representation or guarantee regarding the suitability of its products for any particular purpose, nor does Freescale Semiconductor assume any liability arising out of the application or use of any product or circuit, and specifically disclaims any and all liability, including without limitation consequential or incidental damages. "Typical" parameters that may be provided in Freescale Semiconductor data sheets and/or specifications can and do vary in different applications and actual performance may vary over time. All operating parameters, including "Typicals", must be validated for each customer application by customer's technical experts. Freescale Semiconductor does not convey any license under its patent rights nor the rights of others. Freescale Semiconductor products are not designed, intended, or authorized for use as components in systems intended for surgical implant into the body, or other applications intended to support or sustain life, or for any other application in which the failure of the Freescale Semiconductor product could create a situation where personal injury or death may occur. Should Buyer purchase or use Freescale Semiconductor products for any such unintended or unauthorized application, Buyer shall indemnify and hold Freescale Semiconductor and its officers, employees, subsidiaries, affiliates, and distributors harmless against all claims, costs, damages, and expenses, and reasonable attorney fees arising out of, directly or indirectly, any claim of personal injury or death associated with such unintended or unauthorized use, even if such claim alleges that Freescale Semiconductor was negligent regarding the design or manufacture of the part.

Freescale™ and the Freescale logo are trademarks of Freescale Semiconductor, Inc. All other product or service names are the property of their respective owners.

© Freescale Semiconductor, Inc. 2008. All rights reserved.

Looking for pricing, stock, or lifecycle information?

Click below to explore more details on WIN SOURCE:

 [View MRFG35010 on WIN SOURCE](#)

 [NXP / Nexperia Information](#)

Optimize Your Supply Chain with WIN SOURCE Solutions

-  Global Sourcing Solution
-  Obsolete Management
-  Cost Control Management
-  Shortage Management
-  Alternative Solution
-  Excess Inventory Management