



**THE DATASHEET OF
SN65LBC173AN**



SN65LBC173A, SN75LBC173A QUADRUPLE RS-485 DIFFERENTIAL LINE RECEIVERS

SLLS456B – NOVEMBER 2000 – REVISED APRIL 2005

- Designed for TIA/EIA-485, TIA/EIA-422, and ISO 8482 Applications
- Signaling Rate† Exceeding 50 Mbps
- Fail-Safe in Bus Short-Circuit, Open-Circuit, and Idle-Bus Conditions
- ESD Protection on Bus Inputs Exceeds 6 kV
- Common-Mode Bus Input Range –7 V to 12 V
- Propagation Delay Times <16 ns
- Low Standby Power Consumption <20 μ A
- Pin-Compatible Upgrade for AM26LS32, DS96F173, LTC488, and SN75173

SN65LBC173A (Marked as 65LBC173A)
SN75LBC173A (Marked as 75LBC173A)
D or N PACKAGE
(TOP VIEW)

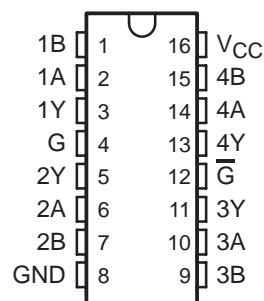

logic diagram

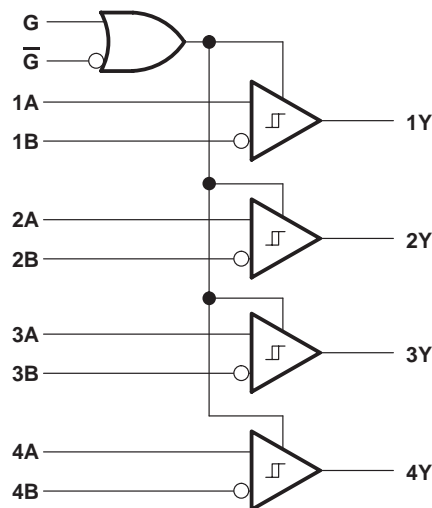

description

The SN65LBC173A and SN75LBC173A are quadruple differential line receivers with 3-state outputs, designed for TIA/EIA-485 (RS-485), TIA/EIA-422 (RS-422), and ISO 8482 (Euro RS-485) applications.

These devices are optimized for balanced multipoint bus communication at data rates up to and exceeding 50 million bits per second. The transmission media may be twisted-pair cables, printed-circuit board traces, or backplanes. The ultimate rate and distance of data transfer is dependent upon the attenuation characteristics of the media and the noise coupling to the environment.

Each receiver operates over a wide range of positive and negative common-mode input voltages, and features ESD protection to 6 kV, making it suitable for high-speed multipoint data transmission applications in harsh environments. These devices are designed using LinBiCMOS™, facilitating low power consumption and robustness.

The G and \bar{G} inputs provide enable control logic for either positive- or negative-logic enabling all four drivers. When disabled or powered off, the receiver inputs present a high-impedance to the bus for reduced system loading.

The SN75LBC173A is characterized for operation over the temperature range of 0°C to 70°C. The SN65LBC173A is characterized over the temperature range from –40°C to 85°C.



Please be aware that an important notice concerning availability, standard warranty, and use in critical applications of Texas Instruments semiconductor products and disclaimers thereto appears at the end of this data sheet.

LinBiCMOS is a trademark of Texas Instruments.

†The signaling rate of a line is the number of voltage transitions that are made per second expressed in the units bps (bits per second).

PRODUCTION DATA information is current as of publication date. Products conform to specifications per the terms of Texas Instruments standard warranty. Production processing does not necessarily include testing of all parameters.

 **TEXAS
INSTRUMENTS**

POST OFFICE BOX 655303 • DALLAS, TEXAS 75265

Copyright © 2001, Texas Instruments Incorporated

SN65LBC173A, SN75LBC173A QUADRUPLE RS-485 DIFFERENTIAL LINE RECEIVERS

SLLS456B – NOVEMBER 2000 – REVISED APRIL 2005

FUNCTION TABLE
(each receiver)

DIFFERENTIAL INPUTS A – B (V_{ID})	ENABLES		OUTPUT Y
	G	\bar{G}	
$V_{ID} \leq -0.2$ V	H	X	L
	X	L	
-0.2 V < V_{ID} < -0.01 V	H	X	?
	X	L	
-0.01 V $\leq V_{ID}$	H	X	H
	X	L	
X	L	H	Z
	OPEN	OPEN	
Short circuit	H	X	H
	X	L	
Open circuit	H	X	H

H = high level, L = low level, X = irrelevant, Z = high impedance (off),
? = indeterminate

AVAILABLE OPTIONS

T_A	PACKAGE	
	PLASTIC SMALL OUTLINE† (JEDEC MS-012)	PLASTIC DUAL-IN-LINE (JEDEC MS-001)
0°C to 70°C	SN75LBC173AD	SN75LBC173AN
-40°C to 85°C	SN65LBC173AD	SN65LBC173AN

† Add an R suffix for taped and reeled

equivalent input and output schematic diagrams

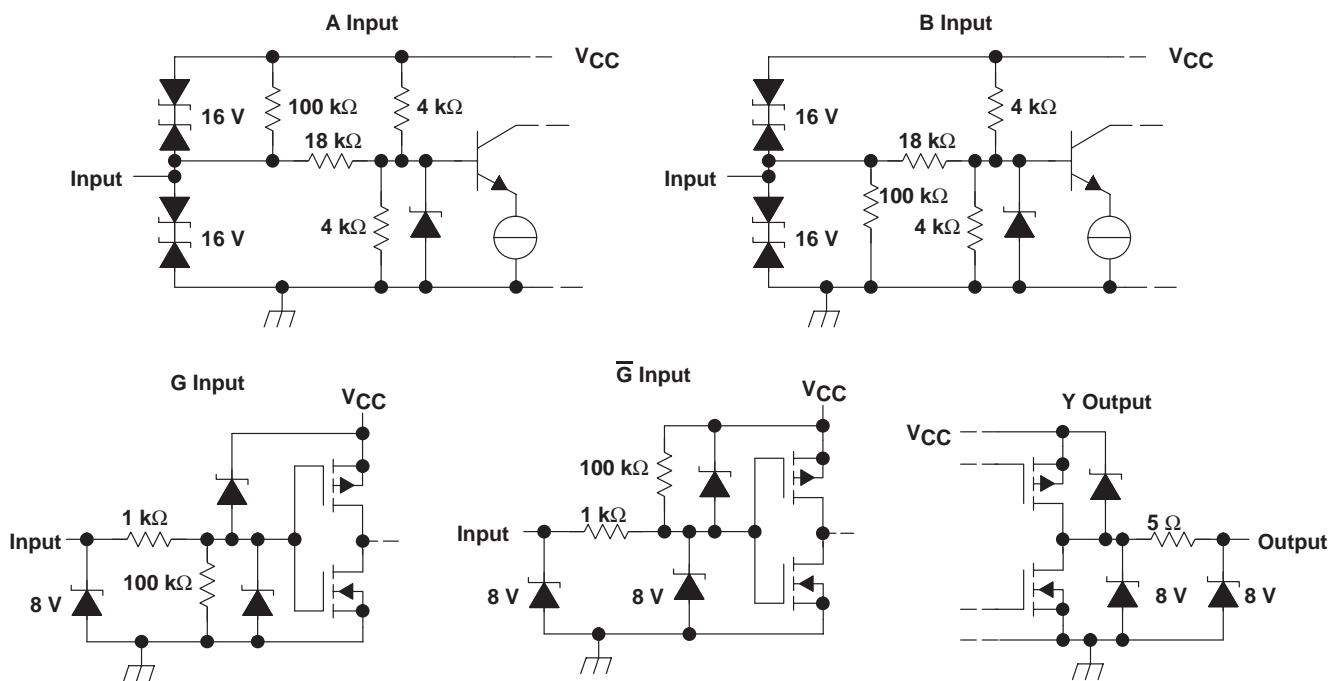

SN65LBC173A, SN75LBC173A QUADRUPLE RS-485 DIFFERENTIAL LINE RECEIVERS

SLLS456B – NOVEMBER 2000 – REVISED APRIL 2005

absolute maximum ratings over operating free-air temperature range (unless otherwise noted)†

Supply voltage range, V_{CC} (see Note 1)	–0.3 V to 6 V
Voltage range at any bus input (DC)	–10 V to 15 V
Voltage range at any bus input (transient pulse through 100 Ω , see Figure 5)	–30 V to 30 V
Voltage input range at G and \bar{G} , V_I	–0.5 V to $V_{CC} + 0.5$ V
Receiver output current, I_O	± 10 mA
Electrostatic discharge:	
Human body model (see Note 2):	A and B to GND 6 kV
	All pins 5 kV
Charged-device model (see Note 3):	All pins 2 kV
Continuous power dissipation	See Power Dissipation Rating Table

† Stresses beyond those listed under “absolute maximum ratings” may cause permanent damage to the device. These are stress ratings only, and functional operation of the device at these or any other conditions beyond those indicated under “recommended operating conditions” is not implied. Exposure to absolute-maximum-rated conditions for extended periods may affect device reliability.

- NOTES: 1. All voltage values, except differential I/O bus voltages, are with respect to GND, and are steady-state (unless otherwise specified).
 2. Tested in accordance with JEDEC Standard 22, Test Method A114-A.
 3. Tested in accordance with JEDEC Standard 22, Test Method C101.

DISSIPATION RATING TABLE

PACKAGE	$T_A \leq 25^\circ\text{C}$ POWER RATING	DERATING FACTOR‡ ABOVE $T_A = 25^\circ\text{C}$	$T_A = 70^\circ\text{C}$ POWER RATING	$T_A = 85^\circ\text{C}$ POWER RATING
D	1080 mW	8.7 mW/ $^\circ\text{C}$	690 mW	560 mW
N	1150 mW	9.2 mW/ $^\circ\text{C}$	736 mW	598 mW

‡ This is the inverse of the junction-to-ambient thermal resistance when board-mounted and with no air flow.

recommended operating conditions

		MIN	NOM	MAX	UNIT
Supply voltage, V_{CC}		4.75	5	5.25	V
Voltage at any bus terminal	A, B	–7		12	V
High-level input voltage, V_{IH}	G, \bar{G}	2		V_{CC}	V
Low-level input voltage, V_{IL}		0		0.8	
Output current	Y	–8		8	mA
Operating free-air temperature, T_A	SN75LBC173A	0		70	$^\circ\text{C}$
	SN65LBC173A	–40		85	

SN65LBC173A, SN75LBC173A QUADRUPLE RS-485 DIFFERENTIAL LINE RECEIVERS

SLLS456B – NOVEMBER 2000 – REVISED APRIL 2005

electrical characteristics over recommended operating conditions

PARAMETER		TEST CONDITIONS	MIN	TYP†	MAX	UNIT
V_{IT+}	Positive-going differential input voltage threshold	$-7\text{ V} \leq V_{CM} \leq 12\text{ V}$ ($V_{CM} = (V_A + V_B)/2$)	-80	-10		mV
V_{IT-}	Negative-going differential input voltage threshold		-200	-120		
V_{HYS}	Hysteresis voltage ($V_{IT+} - V_{IT-}$)		40			mV
V_{IK}	Input clamp voltage	$I_I = -18\text{ mA}$	-1.5	-0.8		V
V_{OH}	High-level output voltage	$V_{ID} = 200\text{ mV}$, $I_{OH} = -8\text{ mA}$	2.7	4.8		V
V_{OL}	Low-level output voltage	$V_{ID} = -200\text{ mV}$, $I_{OL} = 8\text{ mA}$				
I_{OZ}	High-impedance-state output current	$V_O = 0\text{ V to } V_{CC}$	-1		1	μA
I_I	Line input current	Other input at 0 V, $V_{CC} = 0\text{ V or } 5\text{ V}$	$V_I = 12\text{ V}$		0.9	mA
			$V_I = -7\text{ V}$		-0.7	
I_{IH}	High-level input current	Enable inputs G, \bar{G}			100	μA
I_{IL}	Low-level input current				-100	μA
R_I	Input resistance	A, B inputs	12			$\text{k}\Omega$
I_{CC}	Supply current	$V_{ID} = 5\text{ V}$	G at 0 V, \bar{G} at V_{CC}		20	μA
		No load	G at V_{CC} , \bar{G} at 0 V		11 16	mA

† All typical values are at $V_{CC} = 5\text{ V}$ and 25°C .

switching characteristics over recommended operating conditions

PARAMETER		TEST CONDITIONS	MIN	TYP†	MAX	UNIT
t_r	Output rise time	$V_{ID} = -3\text{ V to } 3\text{ V}$, See Figure 2		2	4	ns
t_f	Output fall time			2	4	ns
t_{PLH}	Propagation delay time, low-to-high level output		9	12	16	ns
t_{PHL}	Propagation delay time, high-to-low level output		9	12	16	ns
t_{PZH}	Propagation delay time, high-impedance to high-level output	See Figure 3		27	38	ns
t_{PHZ}	Propagation delay time, high-level to high-impedance output			7	16	ns
t_{PZL}	Propagation delay time, high-impedance to low level output	See Figure 4		29	38	ns
t_{PLZ}	Propagation delay time, low-level to high-impedance output			12	16	ns
$t_{sk(p)}$	Pulse skew ($ t_{PLH} - t_{PHL} $)			0.2	1	ns
$t_{sk(o)}$	Output skew (see Note 4)				2	ns
$t_{sk(pp)}$	Part-to-part skew (see Note 5)				2	ns

† All typical values are at $V_{CC} = 5\text{ V}$ and 25°C .

- NOTES: 4. Outputs skew ($t_{sk(o)}$) is the magnitude of the time delay difference between the outputs of a single device with all of the inputs connected together.
5. Part-to-part skew ($t_{sk(pp)}$) is the magnitude of the difference in propagation delay times between any specified terminals of two devices when both devices operate with the same input signals, the same supply voltages, at the same temperature, and have identical packages and test circuits.

PARAMETER MEASUREMENT INFORMATION

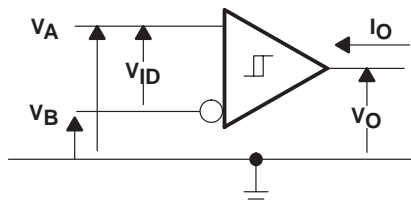

Figure 1. Voltage and Current Definitions

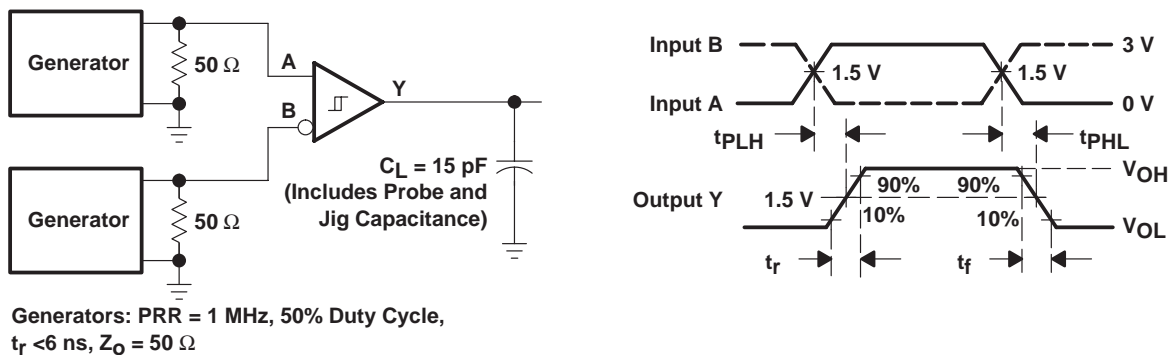

Figure 2. Switching Test Circuit and Waveforms

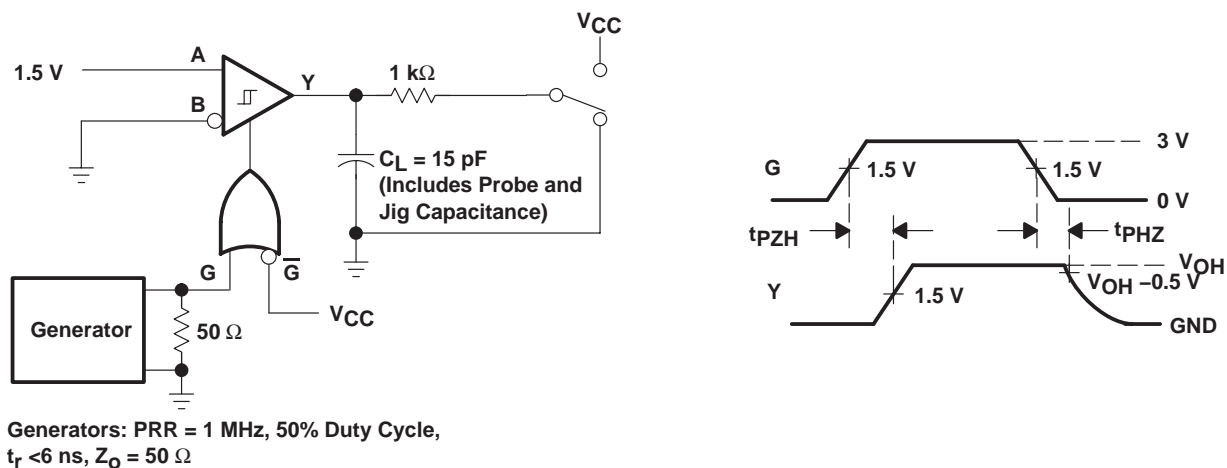
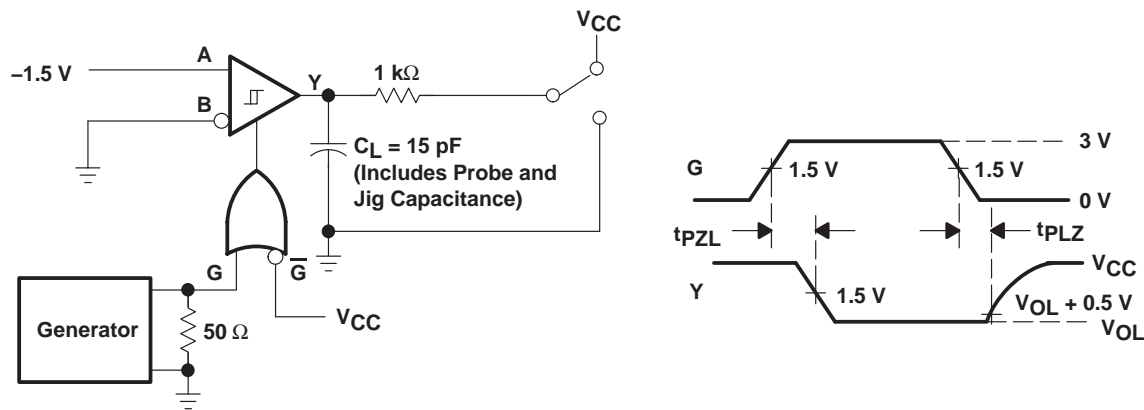

Figure 3. Test Circuit Waveforms, t_{PZH} and t_{PHZ}

SN65LBC173A, SN75LBC173A QUADRUPLE RS-485 DIFFERENTIAL LINE RECEIVERS

SLLS456B – NOVEMBER 2000 – REVISED APRIL 2005

PARAMETER MEASUREMENT INFORMATION



Generators: PRR = 1 MHz, 50% Duty Cycle,
 $t_r < 6 \text{ ns}$, $Z_o = 50 \Omega$

Figure 4. Test Circuit Waveforms, t_{pZL} and t_{pLZ}

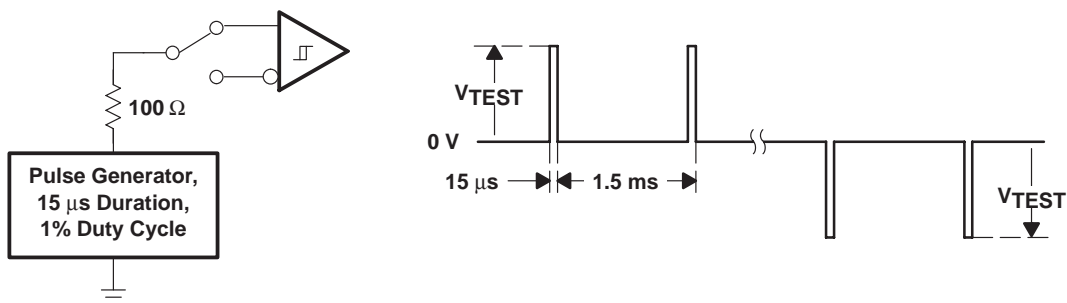

Figure 5. Test Circuit and Waveform, Transient Over-Voltage Test

TYPICAL CHARACTERISTICS

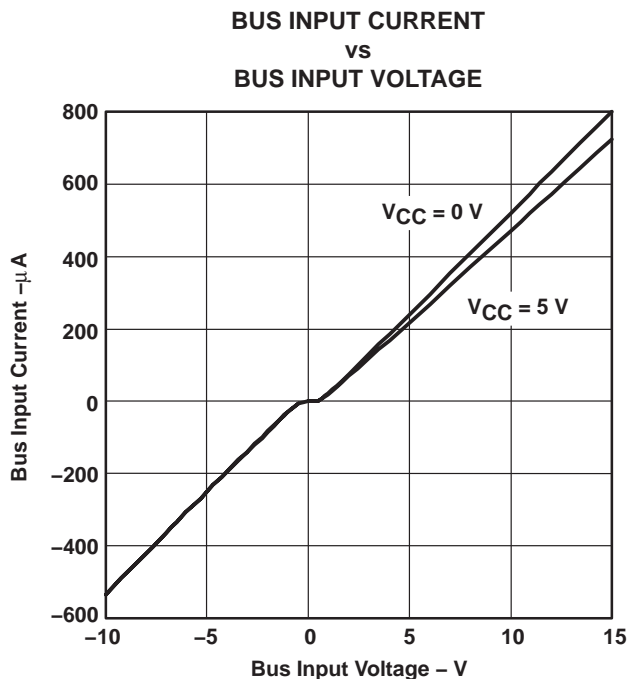

Figure 6

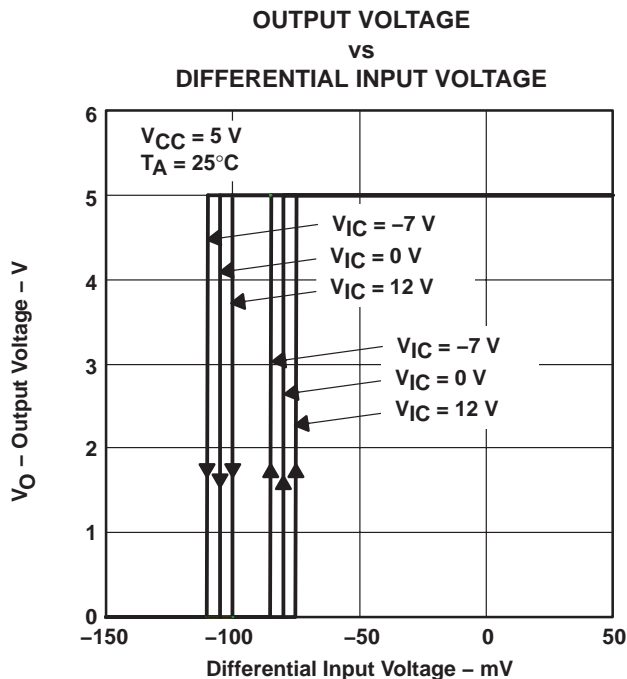

Figure 7

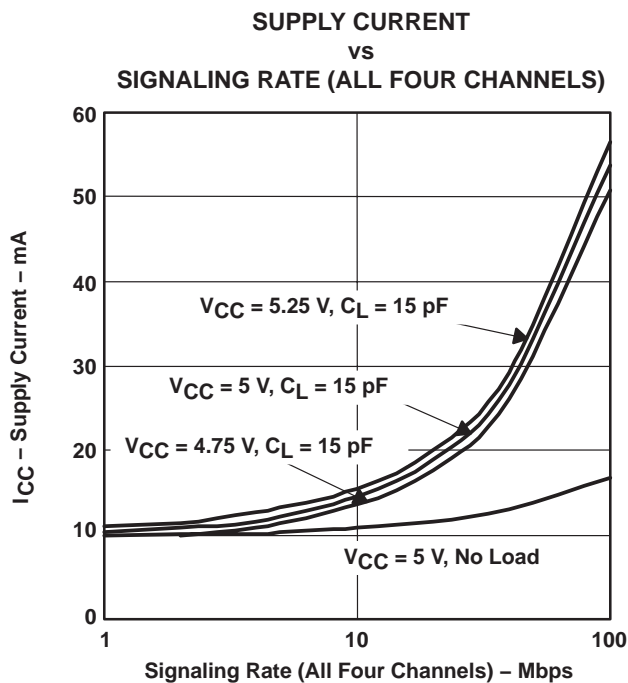

Figure 8

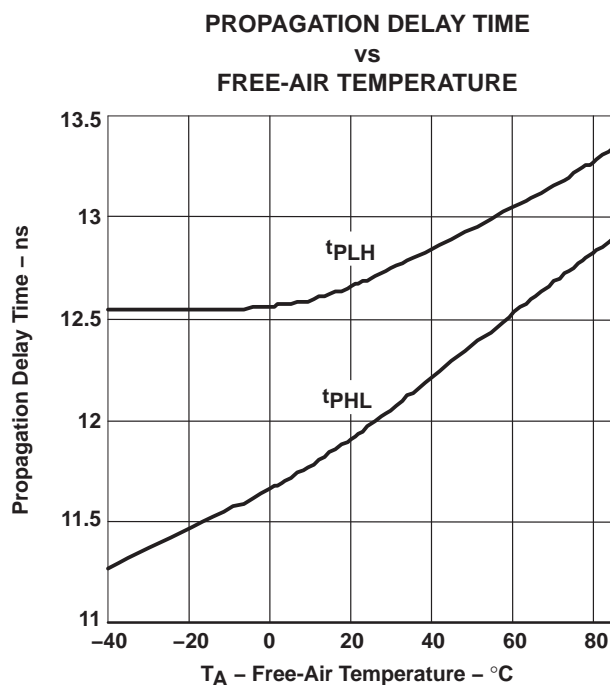

Figure 9

SN65LBC173A, SN75LBC173A QUADRUPLE RS-485 DIFFERENTIAL LINE RECEIVERS

SLLS456B – NOVEMBER 2000 – REVISED APRIL 2005

TYPICAL CHARACTERISTICS

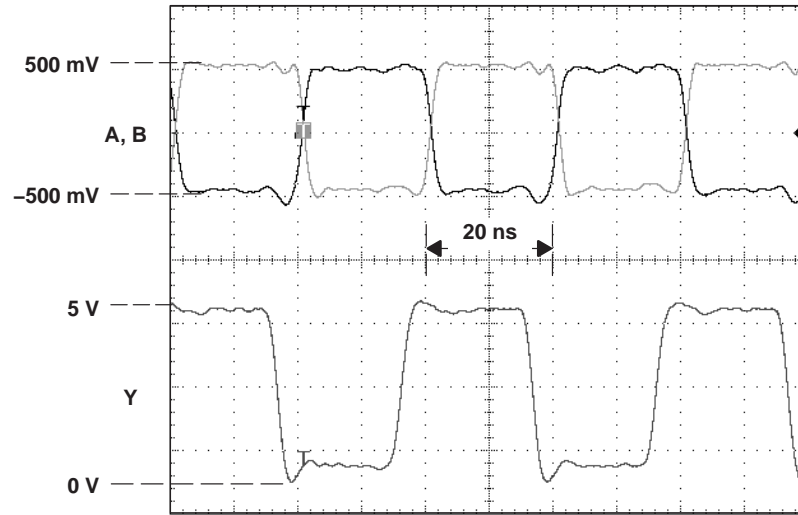

Figure 10. Receiver Inputs and Outputs, 50 Mbps Signaling Rate

SN65LBC173A, SN75LBC173A QUADRUPLE RS-485 DIFFERENTIAL LINE RECEIVERS

SLLS456B – NOVEMBER 2000 – REVISED APRIL 2005

APPLICATION INFORMATION

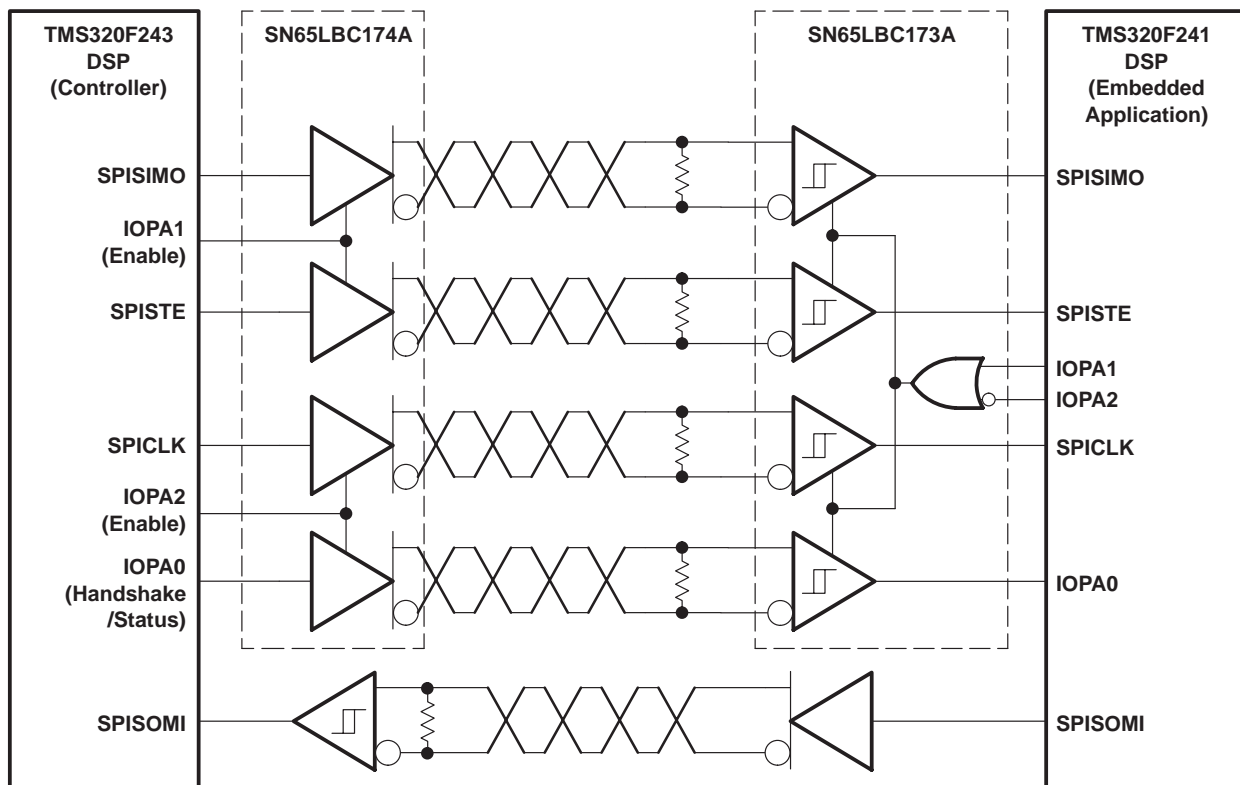

Figure 11. Typical Application Circuit, DSP-to-DSP Link via Serial Peripheral Interface

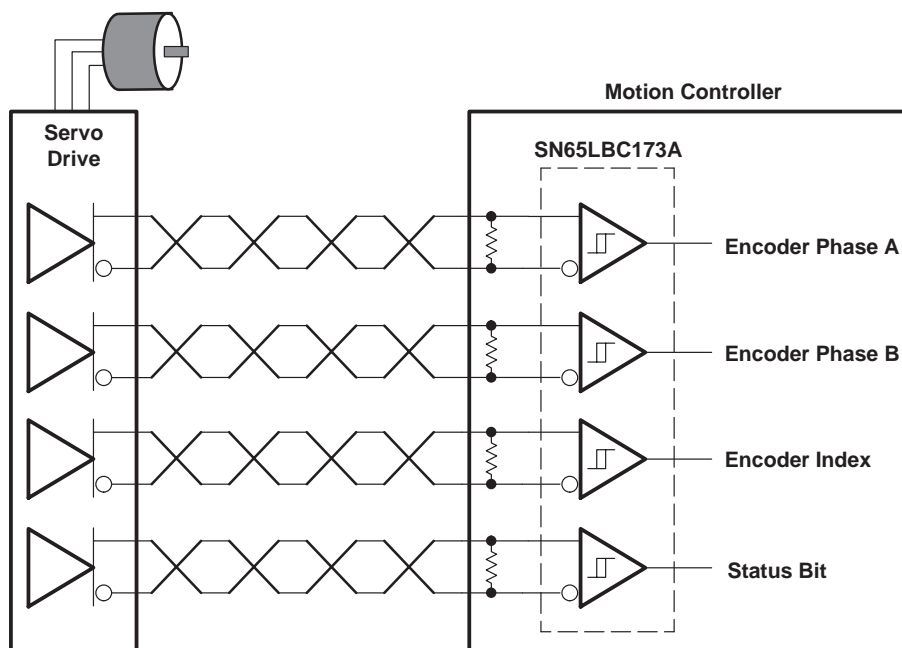

Figure 12. Typical Application Circuit, High-Speed Servomotor Encoder Interface

PACKAGING INFORMATION

Orderable Device	Status (1)	Package Type	Package Drawing	Pins	Package Qty	Eco Plan (2)	Lead/Ball Finish (6)	MSL Peak Temp (3)	Op Temp (°C)	Device Marking (4/5)	Samples
SN65LBC173AD	ACTIVE	SOIC	D	16	40	Green (RoHS & no Sb/Br)	CU NIPDAU	Level-1-260C-UNLIM	-40 to 85	65LBC173A	Samples
SN65LBC173ADG4	ACTIVE	SOIC	D	16	40	Green (RoHS & no Sb/Br)	CU NIPDAU	Level-1-260C-UNLIM	-40 to 85	65LBC173A	Samples
SN65LBC173ADR	ACTIVE	SOIC	D	16	2500	Green (RoHS & no Sb/Br)	CU NIPDAU	Level-1-260C-UNLIM	-40 to 85	65LBC173A	Samples
SN65LBC173AN	ACTIVE	PDIP	N	16	25	Green (RoHS & no Sb/Br)	CU NIPDAU	N / A for Pkg Type	-40 to 85	65LBC173A	Samples
SN75LBC173AD	ACTIVE	SOIC	D	16	40	Green (RoHS & no Sb/Br)	CU NIPDAU	Level-1-260C-UNLIM	0 to 70	75LBC173A	Samples
SN75LBC173ADR	ACTIVE	SOIC	D	16	2500	Green (RoHS & no Sb/Br)	CU NIPDAU	Level-1-260C-UNLIM	0 to 70	75LBC173A	Samples
SN75LBC173AN	ACTIVE	PDIP	N	16	25	Green (RoHS & no Sb/Br)	CU NIPDAU	N / A for Pkg Type	0 to 70	75LBC173A	Samples

(1) The marketing status values are defined as follows:

ACTIVE: Product device recommended for new designs.

LIFEBUY: TI has announced that the device will be discontinued, and a lifetime-buy period is in effect.

NRND: Not recommended for new designs. Device is in production to support existing customers, but TI does not recommend using this part in a new design.

PREVIEW: Device has been announced but is not in production. Samples may or may not be available.

OBSELETE: TI has discontinued the production of the device.

(2) **RoHS:** TI defines "RoHS" to mean semiconductor products that are compliant with the current EU RoHS requirements for all 10 RoHS substances, including the requirement that RoHS substance do not exceed 0.1% by weight in homogeneous materials. Where designed to be soldered at high temperatures, "RoHS" products are suitable for use in specified lead-free processes. TI may reference these types of products as "Pb-Free".

RoHS Exempt: TI defines "RoHS Exempt" to mean products that contain lead but are compliant with EU RoHS pursuant to a specific EU RoHS exemption.

Green: TI defines "Green" to mean the content of Chlorine (Cl) and Bromine (Br) based flame retardants meet JS709B low halogen requirements of <=100ppm threshold. Antimony trioxide based flame retardants must also meet the <=1000ppm threshold requirement.

(3) MSL, Peak Temp. - The Moisture Sensitivity Level rating according to the JEDEC industry standard classifications, and peak solder temperature.

(4) There may be additional marking, which relates to the logo, the lot trace code information, or the environmental category on the device.

(5) Multiple Device Markings will be inside parentheses. Only one Device Marking contained in parentheses and separated by a "-" will appear on a device. If a line is indented then it is a continuation of the previous line and the two combined represent the entire Device Marking for that device.

⁽⁶⁾ Lead/Ball Finish - Orderable Devices may have multiple material finish options. Finish options are separated by a vertical ruled line. Lead/Ball Finish values may wrap to two lines if the finish value exceeds the maximum column width.

Important Information and Disclaimer: The information provided on this page represents TI's knowledge and belief as of the date that it is provided. TI bases its knowledge and belief on information provided by third parties, and makes no representation or warranty as to the accuracy of such information. Efforts are underway to better integrate information from third parties. TI has taken and continues to take reasonable steps to provide representative and accurate information but may not have conducted destructive testing or chemical analysis on incoming materials and chemicals. TI and TI suppliers consider certain information to be proprietary, and thus CAS numbers and other limited information may not be available for release.

In no event shall TI's liability arising out of such information exceed the total purchase price of the TI part(s) at issue in this document sold by TI to Customer on an annual basis.

OTHER QUALIFIED VERSIONS OF SN65LBC173A :

- Enhanced Product: [SN65LBC173A-EP](#)

NOTE: Qualified Version Definitions:

- Enhanced Product - Supports Defense, Aerospace and Medical Applications

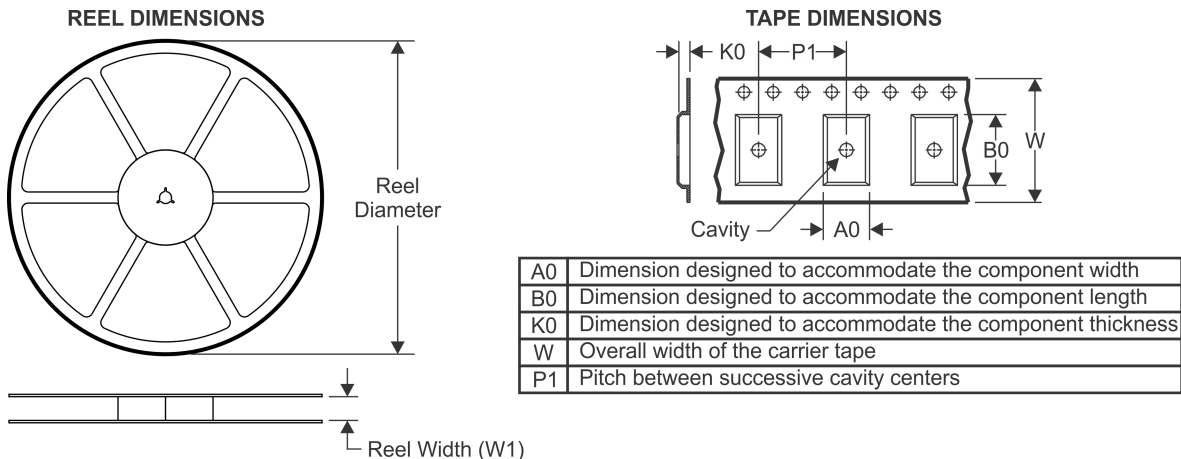
TAPE AND REEL INFORMATION

QUADRANT ASSIGNMENTS FOR PIN 1 ORIENTATION IN TAPE

*All dimensions are nominal

Device	Package Type	Package Drawing	Pins	SPQ	Reel Diameter (mm)	Reel Width W1 (mm)	A0 (mm)	B0 (mm)	K0 (mm)	P1 (mm)	W (mm)	Pin1 Quadrant
SN65LBC173ADR	SOIC	D	16	2500	330.0	16.4	6.5	10.3	2.1	8.0	16.0	Q1
SN75LBC173ADR	SOIC	D	16	2500	330.0	16.4	6.5	10.3	2.1	8.0	16.0	Q1

TAPE AND REEL BOX DIMENSIONS



*All dimensions are nominal

Device	Package Type	Package Drawing	Pins	SPQ	Length (mm)	Width (mm)	Height (mm)
SN65LBC173ADR	SOIC	D	16	2500	333.2	345.9	28.6
SN75LBC173ADR	SOIC	D	16	2500	333.2	345.9	28.6

D (R-PDSO-G16)

PLASTIC SMALL OUTLINE



- NOTES:
- A. All linear dimensions are in inches (millimeters).
 - B. This drawing is subject to change without notice.
 - C. Body length does not include mold flash, protrusions, or gate burrs. Mold flash, protrusions, or gate burrs shall not exceed 0.006 (0,15) each side.
 - D. Body width does not include interlead flash. Interlead flash shall not exceed 0.017 (0,43) each side.
 - E. Reference JEDEC MS-012 variation AC.

D (R-PDSO-G16)

PLASTIC SMALL OUTLINE

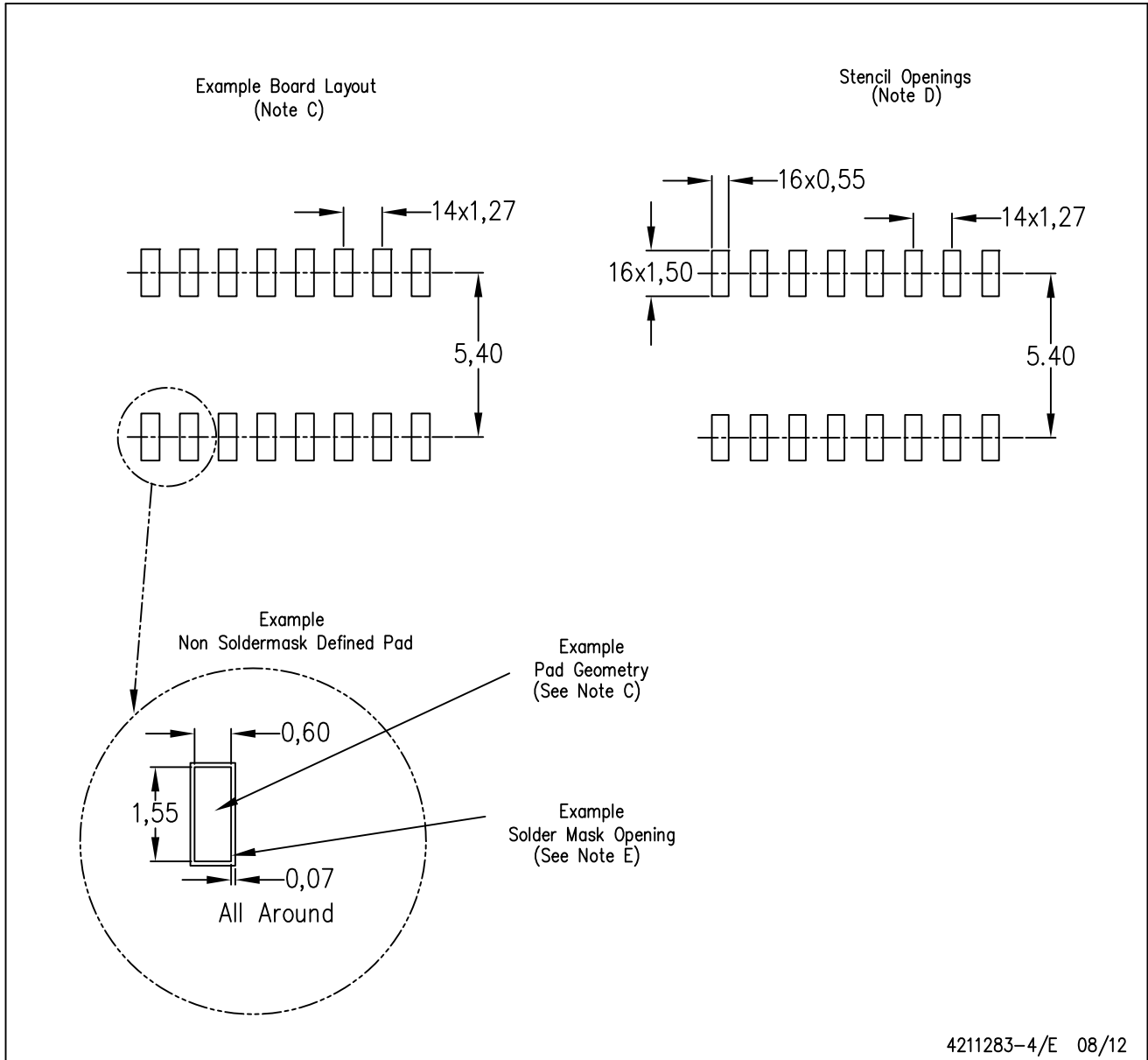

- NOTES:
- All linear dimensions are in millimeters.
 - This drawing is subject to change without notice.
 - Publication IPC-7351 is recommended for alternate designs.
 - Laser cutting apertures with trapezoidal walls and also rounding corners will offer better paste release. Customers should contact their board assembly site for stencil design recommendations. Refer to IPC-7525 for other stencil recommendations.
 - Customers should contact their board fabrication site for solder mask tolerances between and around signal pads.

N (R-PDIP-T**)

PLASTIC DUAL-IN-LINE PACKAGE

16 PINS SHOWN



- NOTES:
- A. All linear dimensions are in inches (millimeters).
 - B. This drawing is subject to change without notice.
 - Falls within JEDEC MS-001, except 18 and 20 pin minimum body length (Dim A).
 - The 20 pin end lead shoulder width is a vendor option, either half or full width.

IMPORTANT NOTICE

Texas Instruments Incorporated (TI) reserves the right to make corrections, enhancements, improvements and other changes to its semiconductor products and services per JESD46, latest issue, and to discontinue any product or service per JESD48, latest issue. Buyers should obtain the latest relevant information before placing orders and should verify that such information is current and complete.

TI's published terms of sale for semiconductor products (<http://www.ti.com/sc/docs/stdterms.htm>) apply to the sale of packaged integrated circuit products that TI has qualified and released to market. Additional terms may apply to the use or sale of other types of TI products and services.

Reproduction of significant portions of TI information in TI data sheets is permissible only if reproduction is without alteration and is accompanied by all associated warranties, conditions, limitations, and notices. TI is not responsible or liable for such reproduced documentation. Information of third parties may be subject to additional restrictions. Resale of TI products or services with statements different from or beyond the parameters stated by TI for that product or service voids all express and any implied warranties for the associated TI product or service and is an unfair and deceptive business practice. TI is not responsible or liable for any such statements.

Buyers and others who are developing systems that incorporate TI products (collectively, "Designers") understand and agree that Designers remain responsible for using their independent analysis, evaluation and judgment in designing their applications and that Designers have full and exclusive responsibility to assure the safety of Designers' applications and compliance of their applications (and of all TI products used in or for Designers' applications) with all applicable regulations, laws and other applicable requirements. Designer represents that, with respect to their applications, Designer has all the necessary expertise to create and implement safeguards that (1) anticipate dangerous consequences of failures, (2) monitor failures and their consequences, and (3) lessen the likelihood of failures that might cause harm and take appropriate actions. Designer agrees that prior to using or distributing any applications that include TI products, Designer will thoroughly test such applications and the functionality of such TI products as used in such applications.

TI's provision of technical, application or other design advice, quality characterization, reliability data or other services or information, including, but not limited to, reference designs and materials relating to evaluation modules, (collectively, "TI Resources") are intended to assist designers who are developing applications that incorporate TI products; by downloading, accessing or using TI Resources in any way, Designer (individually or, if Designer is acting on behalf of a company, Designer's company) agrees to use any particular TI Resource solely for this purpose and subject to the terms of this Notice.

TI's provision of TI Resources does not expand or otherwise alter TI's applicable published warranties or warranty disclaimers for TI products, and no additional obligations or liabilities arise from TI providing such TI Resources. TI reserves the right to make corrections, enhancements, improvements and other changes to its TI Resources. TI has not conducted any testing other than that specifically described in the published documentation for a particular TI Resource.

Designer is authorized to use, copy and modify any individual TI Resource only in connection with the development of applications that include the TI product(s) identified in such TI Resource. NO OTHER LICENSE, EXPRESS OR IMPLIED, BY ESTOPPEL OR OTHERWISE TO ANY OTHER TI INTELLECTUAL PROPERTY RIGHT, AND NO LICENSE TO ANY TECHNOLOGY OR INTELLECTUAL PROPERTY RIGHT OF TI OR ANY THIRD PARTY IS GRANTED HEREIN, including but not limited to any patent right, copyright, mask work right, or other intellectual property right relating to any combination, machine, or process in which TI products or services are used. Information regarding or referencing third-party products or services does not constitute a license to use such products or services, or a warranty or endorsement thereof. Use of TI Resources may require a license from a third party under the patents or other intellectual property of the third party, or a license from TI under the patents or other intellectual property of TI.

TI RESOURCES ARE PROVIDED "AS IS" AND WITH ALL FAULTS. TI DISCLAIMS ALL OTHER WARRANTIES OR REPRESENTATIONS, EXPRESS OR IMPLIED, REGARDING RESOURCES OR USE THEREOF, INCLUDING BUT NOT LIMITED TO ACCURACY OR COMPLETENESS, TITLE, ANY EPIDEMIC FAILURE WARRANTY AND ANY IMPLIED WARRANTIES OF MERCHANTABILITY, FITNESS FOR A PARTICULAR PURPOSE, AND NON-INFRINGEMENT OF ANY THIRD PARTY INTELLECTUAL PROPERTY RIGHTS. TI SHALL NOT BE LIABLE FOR AND SHALL NOT DEFEND OR INDEMNIFY DESIGNER AGAINST ANY CLAIM, INCLUDING BUT NOT LIMITED TO ANY INFRINGEMENT CLAIM THAT RELATES TO OR IS BASED ON ANY COMBINATION OF PRODUCTS EVEN IF DESCRIBED IN TI RESOURCES OR OTHERWISE. IN NO EVENT SHALL TI BE LIABLE FOR ANY ACTUAL, DIRECT, SPECIAL, COLLATERAL, INDIRECT, PUNITIVE, INCIDENTAL, CONSEQUENTIAL OR EXEMPLARY DAMAGES IN CONNECTION WITH OR ARISING OUT OF TI RESOURCES OR USE THEREOF, AND REGARDLESS OF WHETHER TI HAS BEEN ADVISED OF THE POSSIBILITY OF SUCH DAMAGES.

Unless TI has explicitly designated an individual product as meeting the requirements of a particular industry standard (e.g., ISO/TS 16949 and ISO 26262), TI is not responsible for any failure to meet such industry standard requirements.

Where TI specifically promotes products as facilitating functional safety or as compliant with industry functional safety standards, such products are intended to help enable customers to design and create their own applications that meet applicable functional safety standards and requirements. Using products in an application does not by itself establish any safety features in the application. Designers must ensure compliance with safety-related requirements and standards applicable to their applications. Designer may not use any TI products in life-critical medical equipment unless authorized officers of the parties have executed a special contract specifically governing such use. Life-critical medical equipment is medical equipment where failure of such equipment would cause serious bodily injury or death (e.g., life support, pacemakers, defibrillators, heart pumps, neurostimulators, and implantables). Such equipment includes, without limitation, all medical devices identified by the U.S. Food and Drug Administration as Class III devices and equivalent classifications outside the U.S.

TI may expressly designate certain products as completing a particular qualification (e.g., Q100, Military Grade, or Enhanced Product). Designers agree that it has the necessary expertise to select the product with the appropriate qualification designation for their applications and that proper product selection is at Designers' own risk. Designers are solely responsible for compliance with all legal and regulatory requirements in connection with such selection.

Designer will fully indemnify TI and its representatives against any damages, costs, losses, and/or liabilities arising out of Designer's non-compliance with the terms and provisions of this Notice.

Looking for pricing, stock, or lifecycle information?

Click below to explore more details on WIN SOURCE:

 [View SN65LBC173AN on WIN SOURCE](#)

 [Texas Instruments](#) Information

Optimize Your Supply Chain with WIN SOURCE Solutions

-  Global Sourcing Solution
-  Obsolete Management
-  Cost Control Management
-  Shortage Management
-  Alternative Solution
-  Excess Inventory Management