



**THE DATASHEET OF
TA1K0PH2R50KE**



TA1K & TA2K

High Wattage Heat Sinkable Planar Resistor

The TAP series delivers 1000W or 2000W of continuous power when properly mounted to a liquid cooled heat sink (based on 85°C mounting plate temperature)

Applications include power conditioning, power distribution, power conversion, and power control.



FEATURES

- High Energy Rating
- Low Inductance
- Resistor Element Electrically Isolated
- High Dielectric Strength
- Small Footprint

APPLICATIONS

- Power semiconductor balancing
- Motor control
- Inrush Current Limiting

CHARACTERISTICS

| | |
|------------------------------------|---------------------------------------|
| Resistor Element | Thick Film on Alumina Substrate |
| Power Rating | 1000W or 2000W at 85°C mounting plate |
| Resistance Values | 0.5Ω to 1000Ω |
| Resistance Tolerance | +10% std. |
| Max Operating Voltage | 2000VDC |
| Temperature Coefficient | ± 250 PPM/°C |
| Dielectric Strength | 6KV standard |
| Operating Temperature Range | -55°C to 85°C |
| Terminal Screws | #10-32 |
| Max Contacts Torque | 10 in-lb |
| Mounting Screws | #8-32 |
| Max Mounting Torque | 15 in-lb |
| Creepage Distance | 50mm ± 1mm (min) |

| Test | Rating | |
|---|--------------------------------|---------|
| | Continuous | Pulse |
| Rated Power, max. current and heat sink plate temperature limited | (TA1K0) 1000W (TA2K0) 2000W | |
| Operating Voltage | $\sqrt{P \cdot R}$ | N/A |
| Max. Applied Voltage, ohms law limited | 223V | 2000VDC |
| Max. Current | 10A | 53.33A |
| Critical Resistance; below this resistance max power has to be de-rated due to exceeding max current | (TA1K0) 10Ω (TA2K0) 20Ω | |

| Test | Method | Maximum ΔR |
|----------------------------|--|-----------------------------|
| Short Time Overload | $1.14 \times \sqrt{P \cdot R} / 10 \text{ sec @ } 70^\circ\text{C}$ | Max % ΔRsto = ±(2% + 0.05Ω) |
| Moisture Resistance | (TA1K0) 1000 hrs @ 40°C, 90-95% RH (TA2K0) 1750 hrs @ 40°C, 90-95% RH | ≤1% |
| Thermal Shock | MIL-STD-202, Method 107 | MIL-STD-202, Method 107 |
| Vibration, elec. | MIL-STD-202, Method 201 | ±2% Resistance |
| Vibration, mech. | MIL-STD-202, Method 201 | No Loose Terminal Screws |
| Load Life | (TA1K0) 1000 Hrs 90 min ON / 30 min OFF (TA2K0) 1750 Hrs 90 min ON / 30 min OFF | ≤1% |
| Pulse Tolerance | 52μF @ 2KV / 60 sec intervals, 104J, 20,000 Pulses | ≤1% |
| Dielectric Strength | 6KVDC for 1 minute | ≤1% |

Derating

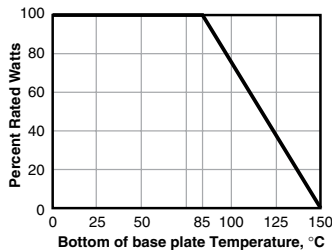

(continued)

TA1K & TA2K

High Wattage Heat Sinkable Planar Resistor

DIMENSIONS

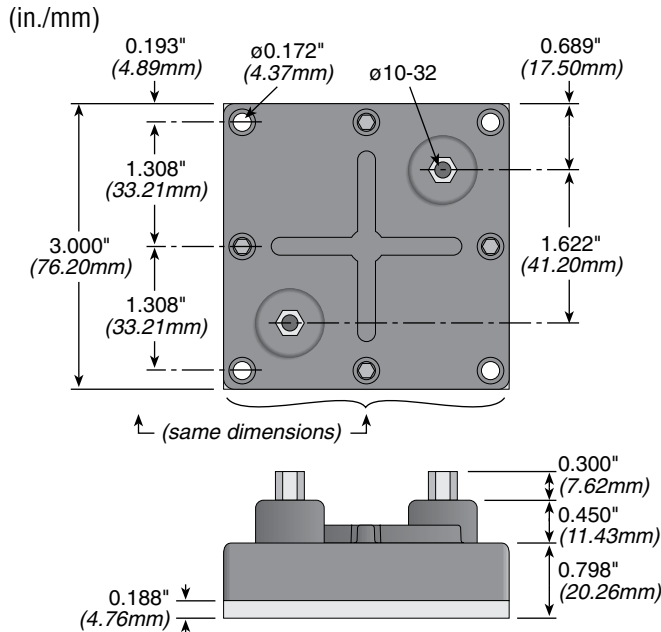

APPLICATION NOTES

Proper heat sinking techniques are essential to performance of a TAP resistor. Please follow these guidelines when designing TAP system:

- Heats sink plate (base plate of the resistor) temperature must be monitored to establish proper de-rating. Best technique is to attach a thermocouple to the side of the base plate of the resistor. Temperature of plastic housing or heat sink cannot be used to establish rating of the resistor. Usage of laser thermometers should be avoided.
- To obtain a power rating of 1000W or 2000W, the bottom case temp must not exceed 85°C. This can only be achieved if the thermal conduction to the heatsink $R_{th-cs} < 0.025^\circ\text{K/W}$. This value can be reached by using thermal transfer compound with a heat conductivity of 1W/mK. The flatness of the cooling plate must be better than 0.05mm overall. The roughness of the surface should not exceed 6.4µm.
- Due to very high power density, only liquid cooled heat sinks are recommended for applications when >300W power rating is desired.
- Properly designed heat sink should have more than 2 cooling pipes under the surface of the TAP resistor. The Ohmite CP4 heat sink (http://www.ohmite.com/cat/sink_cp4.pdf) is an example of properly designed heat sink.

ORDERING INFORMATION

RoHS Compliant

TA1K0PH2R50KE

| | | | | |
|-------|---------|--------------|---------------------------|-------------------------------|
| Style | Wattage | Package Type | Resistance | Tolerance |
| | | | 2.5Ω = 2R50 50Ω = 50R0 | K = 10% (standard) L = 20% |

Standard Part Numbers

| Ohms | 1000 Watt 10% Tolerance | | Ohms | 2000 Watt 10% Tolerance | |
|------|----------------------------|-------------|---------------|----------------------------|--|
| | Part Number | Part Number | | | |
| 0.5 | TA1K0PHR500KE | 0.5 | TA2K0PHR500KE | | |
| 1 | TA1K0PH1R00KE | 1 | TA2K0PH1R00KE | | |
| 2.5 | TA1K0PH2R50KE | 2.5 | TA2K0PH2R50KE | | |
| 5 | TA1K0PH5R00KE | 5 | TA2K0PH5R00KE | | |
| 7.5 | TA1K0PH7R50KE | 7.5 | TA2K0PH7R50KE | | |
| 10 | TA1K0PH10R0KE | 10 | TA2K0PH10R0KE | | |
| 15 | TA1K0PH15R0KE | 15 | TA2K0PH15R0KE | | |
| 25 | TA1K0PH25R0KE | 25 | TA2K0PH25R0KE | | |
| 50 | TA1K0PH50R0KE | 50 | TA2K0PH50R0KE | | |
| 100 | TA1K0PH100RKE | 100 | TA2K0PH100RKE | | |
| 250 | TA1K0PH250RKE | 250 | TA2K0PH250RKE | | |
| 500 | TA1K0PH500RKE | 500 | TA2K0PH500RKE | | |
| 750 | TA1K0PH750RKE | 750 | TA2K0PH750RKE | | |
| 1000 | TA1K0PH1K00KE | 1000 | TA2K0PH1K00KE | | |

Looking for pricing, stock, or lifecycle information?

Click below to explore more details on WIN SOURCE:

 [View TA1K0PH2R50KE](#) on WIN SOURCE

 [Ohmite](#) Information

Optimize Your Supply Chain with WIN SOURCE Solutions

-  Global Sourcing Solution
-  Obsolete Management
-  Cost Control Management
-  Shortage Management
-  Alternative Solution
-  Excess Inventory Management