



**THE DATASHEET OF  
MAX138CMH+**





# 3 1/2 Digit A/D Converters with Bandgap Reference and Charge-Pump Voltage Converter

## General Description

The MAX138/MAX139 are 3 1/2 digit A/D converters (ADCs) with on-board LCD (MAX138) and LED (MAX139) display drivers. The MAX138/MAX139 also contain a charge-pump voltage inverter. The charge-pump inverter allows the MAX138/MAX139 to measure both positive and negative input voltages while operating from a single power-supply voltage from +2.5V to +7V. The operating circuits of the MAX138/MAX139 are similar to those of the ICL7136 and ICL7137 respectively, except the MAX138/MAX139 have an internal oscillator and an external charge-pump capacitor connected to pins 38 and 40.

MAX140 is a low segment-current version of the MAX139 intended for use with low-current LED displays.

## Applications

- +5V Powered Panel Meters
- +3V Powered DMMs
- Instruments
- Portable Monitors
- Weigh Scales
- Digital Thermometers

## Pin Configurations

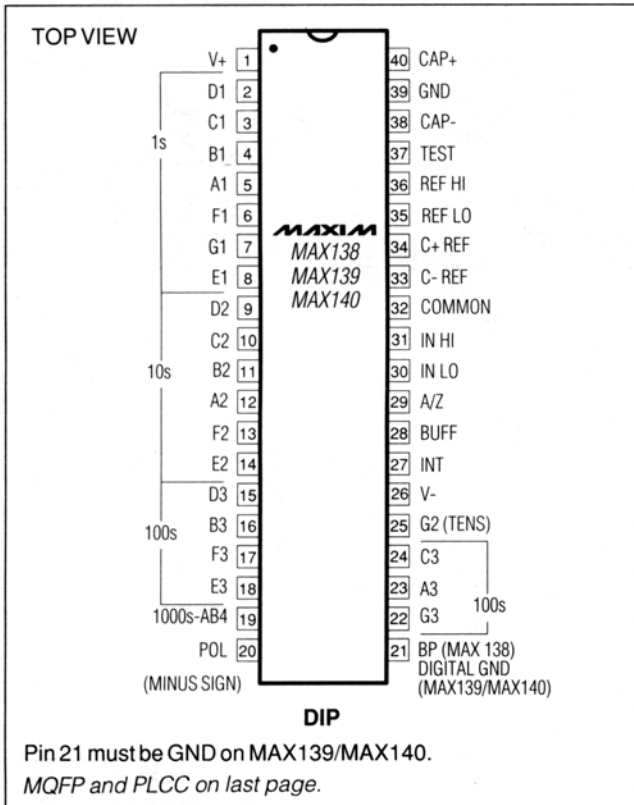

## Features

- ◆ Single Supply +2.5V to +7.0V Operation
- ◆ Measures Both Positive and Negative Input Voltages
- ◆ Charge-Pump Voltage Inverter Generates a Negative Supply Voltage
- ◆ Internal Bandgap Reference
- ◆ On-Board Display Driver
- ◆ Low Segment Current (MAX140)

## Ordering Information

PART	TEMP. RANGE	PIN-PACKAGE
MAX138CPL	0°C to +70°C	40 Plastic DIP
MAX138CMH	0°C to +70°C	44 MQFP
MAX138CQH	0°C to +70°C	44 PLCC
MAX138C/D	0°C to +70°C	Dice*
MAX138EPL	-40°C to +85°C	40 Plastic DIP
MAX138EQH	-40°C to +85°C	44 PLCC
MAX139CPL	0°C to +70°C	40 Plastic DIP
MAX139CMH	0°C to +70°C	44 MQFP
MAX139CQH	0°C to +70°C	44 PLCC
MAX139C/D	0°C to +70°C	Dice*
MAX139EPL	-40°C to +85°C	40 Plastic DIP
MAX139EQH	-40°C to +85°C	44 PLCC
MAX140CPL	0°C to +70°C	40 Plastic DIP
MAX140CMH	0°C to +70°C	44 MQFP
MAX140CQH	0°C to +70°C	44 PLCC
MAX140C/D	0°C to +70°C	Dice*
MAX140EPL	-40°C to +85°C	40 Plastic DIP
MAX140EQH	-40°C to +85°C	44 PLCC

\* Consult factory for dice specifications.

## Typical Operating Circuit

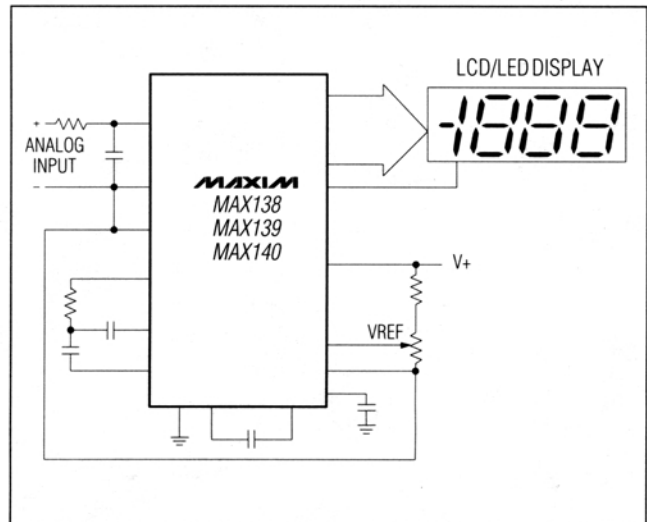

MAX138/MAX139/MAX140



# 3<sup>1</sup>/<sub>2</sub> Digit A/D Converters with Bandgap Reference and Charge-Pump Voltage Converter

## ABSOLUTE MAXIMUM RATINGS (Note 1)

Supply Voltage (V+ to GND)	+7.5V
Supply Voltage (V+ to GND)	
MAX138	+7.5V
MAX139/MAX140	+6.0V
Analog Input Voltage (either input) (Note 2)	V+ to V-
Reference Input Voltage (either input)	V+ to V-
Power Dissipation (Note 3)	
40-Pin Plastic DIP	1333mW
44-Pin PLCC	1067mW
44-Pin MQFP	889mW
Operating Temperature Ranges:	
MAX1__C	0°C to +70°C
MAX1__E	-40°C to +85°C

Storage Temperature Range	-65°C to +160°C
Lead Temperature (Soldering, 10sec.)	+300°C

- Note 1:** V- is generated on the device and is equal to V+, but opposite in polarity.
- Note 2:** Input voltages may exceed the supply voltages, provided the input current is limited to ±1mA.
- Note 3:** Dissipation rating assumes device is mounted with all leads soldered to printed circuit board.

Stresses beyond those listed under "Absolute Maximum Ratings" may cause permanent damage to the device. These are stress ratings only, and functional operation of the device at these or any other conditions beyond those indicated in the operational sections of the specifications is not implied. Exposure to absolute maximum rating conditions for extended periods may affect device reliability.

## ELECTRICAL CHARACTERISTICS (MAX138/MAX139/MAX140)

(V+ = +5V; TA = +25°C; test circuit of Figure 1, unless otherwise noted.)

PARAMETER	CONDITIONS		MIN	TYP	MAX	UNITS
Zero Input Reading	VIN = 0.0V, Full Scale = 200mV	TA = +25°C (Note 4)	-000.0	±000.0	+000.0	Digital Reading
		TMIN ≤ TA ≤ TMAX (Note 5)	-000.0	±000.0	+000.0	
Ratiometric Reading	VIN = VREF, VREF = 100mV	TA = +25°C (Note 4)	999	999/1000	1000	Digital Reading
		TMIN ≤ TA ≤ TMAX (Note 5)	998	999/1000	1001	
Rollover Error (difference in reading for equal positive and negative reading near full scale)	-VIN = +VIN = 200mV	TA = +25°C (Note 4)	-1	±0.2	+1	Counts
		TMIN ≤ TA ≤ TMAX (Note 5)		±0.2		
Linearity (max deviation from best straight-line fit)	Full Scale = 200mV or Full Scale = 2.000V (Note 6)		-1	±0.2	+1	Counts
Common-Mode Rejection Ratio	VCM = ±1V, VIN = 0V, Full Scale = 200mV			50		µV/V
Noise (peak-to-peak value not exceeded 95% of time)	VIN = 0V, Full Scale = 200mV			15		µV
Input Leakage Current	VIN = 0	TA = +25°C (Note 4)		1	10	pA
		TMIN ≤ TA ≤ TMAX		20	200	
Zero Reading Drift	VIN = 0, TMIN ≤ TA ≤ TMAX (Note 4)			0.2		µV/°C
Scale-Factor Temperature Coefficient	VIN = 199mV, TMIN ≤ TA ≤ TMAX (Ext. Ref. 0ppm/°C) (Note 4)			1		ppm/°C
V+ Supply Current (Figure 4A)	VIN = 0	TA = +25°C		200	500	µA
		TMIN ≤ TA ≤ TMAX			800	
Analog Common Voltage (with respect to positive supply)	250kΩ Between Common and Positive Supply		2.95	3.05	3.15	V
Temperature Coefficient of Analog Common (with respect to positive supply)	250kΩ Between Common and Positive Supply	MAX1__ _ PL (Note 7)		±20	±100	ppm/°C
		MAX1__ _ MH/QH		±20		

# 3<sup>1/2</sup> Digit A/D Converters with Bandgap Reference and Charge-Pump Voltage Converter

## ELECTRICAL CHARACTERISTICS (MAX138)

(V<sub>+</sub> = +5V; T<sub>A</sub> = +25°C; test circuit of Figure 1, unless otherwise noted.)

PARAMETERS	CONDITIONS	MIN	TYP	MAX	UNITS
Peak-to-Peak Segment Drive Voltage Peak-to-Peak Backplane Drive Voltage		4	5	6	V
Test-Pin Voltage	With Respect to V <sub>+</sub>	4	5	6	V

## ELECTRICAL CHARACTERISTICS (MAX139/MAX140)

(V<sub>+</sub> = +5V, T<sub>A</sub> = +25°C, test circuit of Figure 2, unless otherwise noted.)

PARAMETER	CONDITIONS		MIN	TYP	MAX	UNITS
Segment Drive Current	MAX139	Except Pin 19	5	9	15	mA
		Pin 19	10	18	30	
	MAX140	Except Pin 19	1.5	2.5	4	mA
		Pin 19	3	5	8	

**Note 4:** Test condition is V<sub>IN</sub> applied between pin IN HI and IN LO through a 1MΩ series resistor as shown in Figures 1 and 2.

**Note 5:** 1MΩ resistor is removed in Figures 1 and 2.

**Note 6:** Guaranteed by design.

**Note 7:** Sample tested to ensure compliance.

### Basic Applications

Figures 1 and 2 show the typical operating circuit for the MAX138/139/140 when powered by a single +5V supply.

### Compatibility with ICL7106, ICL7136, and ICL7137

The MAX138/139/140 can replace the ICL7106/ICL7136/ICL7137 with minor circuit and component value changes. The ICL7106/ICL7136/ICL7137 oscillator components are not used and are replaced with a 1μF capacitor CAP and GND. There must be a 1μF filter capacitor connected to V<sub>-</sub>. The filter capacitor can be connected between either V<sub>-</sub> and GND or V<sub>-</sub> and V<sub>+</sub>.

### System Reference Point

The analog block diagram of the MAX138/MAX139 is shown in Figure 3. The MAX138/MAX139 use the IN LO pin as the reference point for the integrator.

The circuit configuration of the MAX138/MAX139 results in a superior 120dB rejection of common-mode voltages applied to IN HI and IN LO. The MAX138/MAX139 configuration does not have good rejection of AC noise on the IN LO pin during de-integration. If an AC-DC converter is used with a MAX138/MAX139, it should either be a half-wave circuit or should have adequate filtering to avoid inducing additional noise.

### Detailed Description

#### Conversion Method

The MAX138/139/140 use the dual-slope integration method of conversion with the addition of an auto-zero phase to compensate for the offset of the buffer and

integrator and a zero integrator phase to ensure rapid recovery from an overrange conversion. Refer to the ICL7106 data sheet for a detailed description of the conversion phases and timing.

The conversion result is  $1000 \times (\text{IN HI} - \text{IN LO}) / (\text{REF HI} - \text{REF LO})$  with a maximum conversion result of  $\pm 1999$ . If the input voltage is greater than full scale, the MAX138/139/140 will blank the lower three digits and display the leading "1" digit. If the input voltage is negative, the MAX138/139/140 will turn on the minus segment.

#### COMMON Voltage Reference

The COMMON voltage is derived from a bandgap reference, unlike earlier devices which derive the COMMON voltage from a zener. The bandgap reference eliminates the excessive long-term drift associated with low-current zeners, and the MAX138/139/140 can be a source of a high-quality reference voltage without the use of external bandgap reference diodes. The COMMON voltage does have slightly more wideband noise than a zener-derived COMMON voltage, but a 0.1μF or greater reference capacitor will reduce the bandwidth sufficiently to virtually eliminate the noise.

The long-term stability of the COMMON voltage is approximately 0.01% (100ppm or 1/5 count). These devices are sample tested to ensure a maximum temperature coefficient of 100ppm/°C.

The COMMON voltage is buffered by an op amp that has an output impedance of 1Ω, an output sink current of up to 2mA, and a short-circuit current of approximately 25mA max at +3.5V. COMMON has a small pull-up current of 1μA typical which can be driven to a voltage more negative than its internally generated voltage by overpowering the pull-up current source.

# 3 1/2 Digit A/D Converters with Bandgap Reference and Charge-Pump Voltage Converter

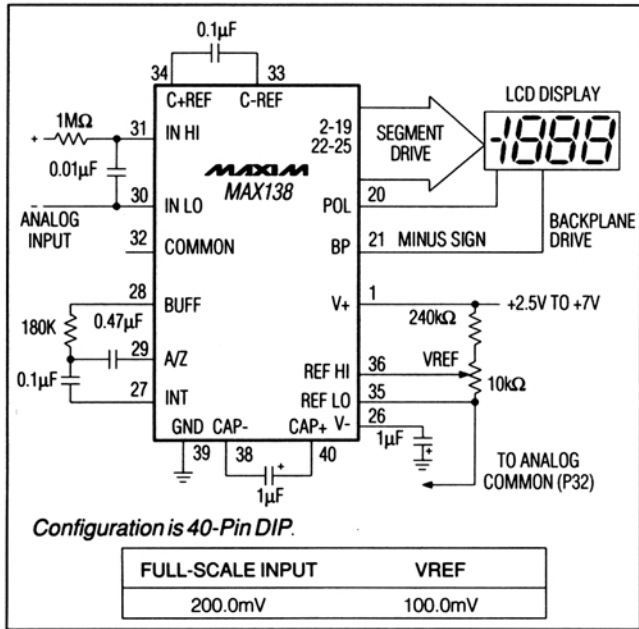

Figure 1. MAX138 Typical Operating Circuit

The COMMON voltage is trimmed to  $+3.05V \pm 100mV$  which is significantly more accurate than the  $+2.4V$  to  $+3.2V$  span allowed in the ICL7106. The better voltage accuracy allows the trim range of the reference voltage to be reduced, increasing resolution and adjustment ease.

### MAX139/MAX140 Test Voltage

This internal test voltage is coupled to the TEST pin via a  $500\Omega$  resistor. When this pin is pulled high, all segments are turned on.

The MAX138/139/140 oscillator circuit uses no external components. It is trimmed during production to 40kHz nominal. This results in a conversion rate of approximately 2.5 conversions per second. The typical characteristics graph (Figure 4B) shows the variation with changes in supply voltage.

### IN LO and IN HI Differential Inputs

These ADCs measure the differential voltage between IN LO and IN HI. The typical common-mode rejection ratio (CMRR) is 120dB.

IN HI has a guaranteed maximum input leakage current of only 10pA and can be directly driven by high source impedances, such as pH sensors and the  $10M\Omega$  input impedance attenuators normally used in digital multimeters. Both IN HI and IN LO have protection clamp diodes to  $V+$  and  $V-$ . If the input voltage can go above  $V+$  or below  $V-$ , the input currents should be limited to less than 1mA to prevent damage to the ADC.

The MAX138/139/140 common-mode voltage range for IN HI and IN LO is a minimum of  $\pm 1V$  around COMMON.

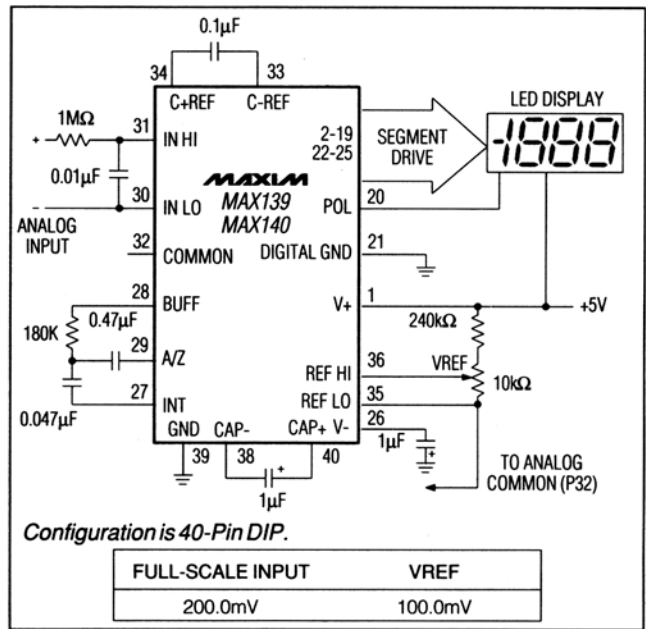

Figure 2. MAX139/MAX140 Typical Operating Circuit

Under some circumstances, IN HI and IN LO can range from  $V- + 1.5V$  to  $V+ - 1.5V$ . See Common-Mode Voltage-Range Considerations section of the Application Notes for further information.

### REFHI, REFLO and CREF Pins

As shown in Figure 3, REF HI and REF LO are connected to the CREF pins during auto-zero and zero-integrate phases via analog switches. This charges an external reference capacitor that is used as either a positive or a negative reference voltage during the de-integration phase. The common-mode voltage range (CMVR) of REF HI and REF LO is  $V+$  to  $V-$ , and any voltage between  $V+$  and  $V-$ , can be used to drive the REF HI and REF LO inputs. The differential voltage between REF HI and REF LO sets the full-scale voltage. A full-scale output of  $\pm 1999$  counts occurs with an input voltage of  $\pm 1.999$  times the differential voltage between REF HI and REF LO. If the differential reference voltage is 1.0V, the full-scale input voltage is 1.999V. With 100mV reference, the full-scale input voltage is 199.9mV.

### LCD Display-Driver Outputs

The MAX138 LCD display-driver outputs swing from  $V+$  to 5V below  $V+$  at a frequency of 20 times the conversion rate with an output impedance of approximately  $3k\Omega$ . The LCD display-driver outputs are not directly driven in-phase with the backplane output to turn an LCD segment off and drive  $180^\circ$  out-of-phase with the backplane output (BP) to turn an LCD segment on.

# 3<sup>1</sup>/<sub>2</sub> Digit A/D Converters with Bandgap Reference and Charge-Pump Voltage Converter

MAX138/MAX139/MAX140

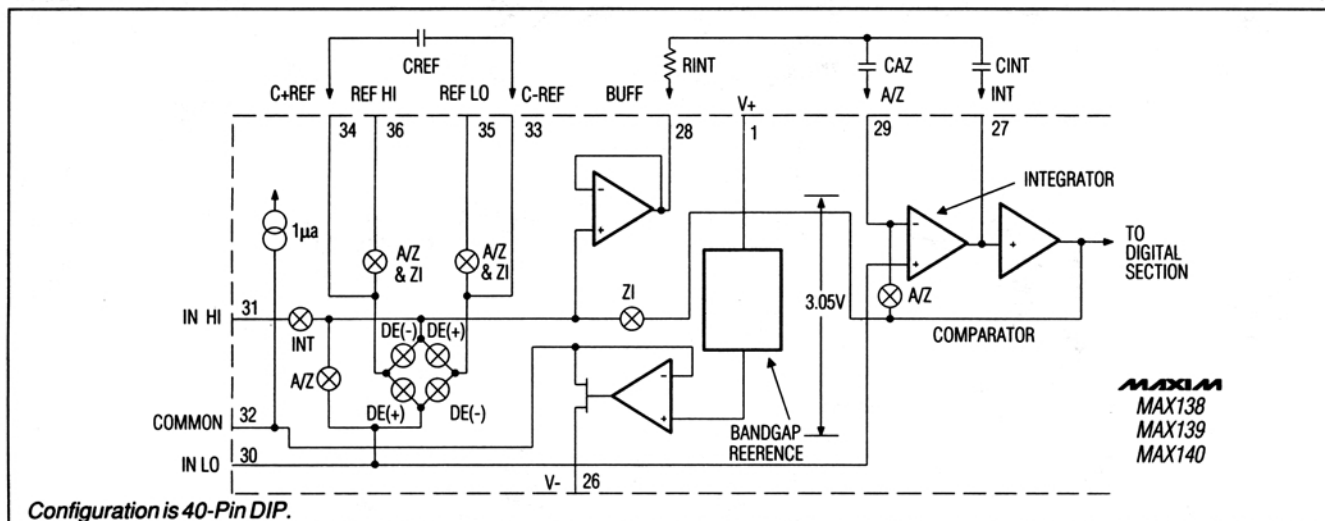

Figure 3. Analog Section of MAX138/139/140

The BP has an output impedance of 500Ω. The LCD drive waveforms are 50% duty cycle with matched rise and fall times to minimize the DC component across the LCD display.

The MAX139/MAX140 LED display-driver outputs are N-channel current sinks with output current vs. voltage characteristics as shown in the Typical Characteristics graphs.

## Component Selection

### Integrator Resistor, RINT

The MAX138/139/140 integrator and buffer amplifiers have a class A output stage that can deliver up to 4µA with high linearity. The MAX138/139/140 integrator resistor is normally chosen to set the maximum current to 1.1µA by setting its value to  $2 \times V_{REF}/1.1\mu A$ . For a 1V reference, the correct value is 1.8MΩ. For a 100mV reference, the correct value is 180k. Since the absolute value of RINT does not affect the conversion accuracy, the type of resistor used for RINT is not critical.

### Integrator Capacitor

The integrator capacitor is normally polypropylene, which has low dielectric absorption. Dielectric absorption will cause integral linearity errors. For example, if polyester or Mylar is used, the measured value of inputs near full scale will be approximately 0.1% lower than expected while the measured value of low input voltages will be as expected.

Proper selection of the integrator capacitor value can be verified by monitoring the output swing of the integrator with  $\pm$ full-scale input voltages. In a properly operating circuit,  $\pm$ full-scale input voltages will cause the integrator output (INT) to swing to about  $\pm 2V$ . INT can drive to about 0.3V from either supply while maintaining high linearity.

If the value of the integrator capacitor or integrator resistor is too low,  $\pm$ full-scale inputs will cause the integrator to

saturate as it attempts to drive above V+ or below V-. If this occurs, operation will appear normal for low input voltages, but the conversion results will be less than full scale for higher output voltages.

Very low integrator swing will increase the amount of noise or flicker of the conversions. A full-scale integrator swing of  $\pm 1V$  is sufficient to avoid any significant degradation of the noise performance and should be used for operation with a +2.5V supply.

### Reference Capacitor

For most circuits, a reference-capacitor value of 0.1µF is adequate. However, a larger value is needed to prevent rollover error if there is significant stray capacitance at the reference-capacitor terminals. Minimize the stray capacitance on the reference-capacitor terminals to reduce the rollover error, and increase the reference capacitor value to 1.0µF if necessary.

The printed circuit board should be carefully cleaned to minimize leakage at the CREF terminals since leakage will cause both gain and rollover errors. Due to the increased leakage of the MAX138/139/140 at +70°C, a 1.0µF reference capacitor is recommended to reduce rollover and gain errors at high temperature.

The reference capacitor is typically a low-leakage film capacitor. Polyester (Mylar) is acceptable in applications where the reference voltage is constant. A low-dielectric absorption capacitor such as polypropylene should be used if the reference voltage is variable since any dielectric absorption will increase the settling time in response to a change in reference voltage. Since the reference voltage varies in circuits that measure resistance ratiometrically, a polypropylene reference capacitor should be used in ohmmeters.

# 3 1/2 Digit A/D Converters with Bandgap Reference and Charge-Pump Voltage Converter

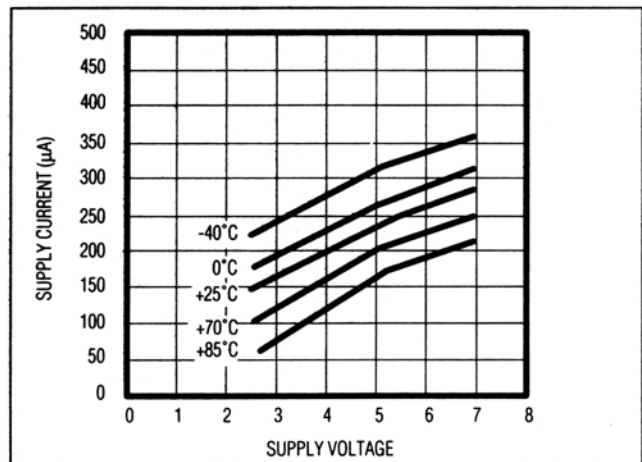

Figure 4A. MAX138/139/140 Typical Supply Current vs. Supply Voltage

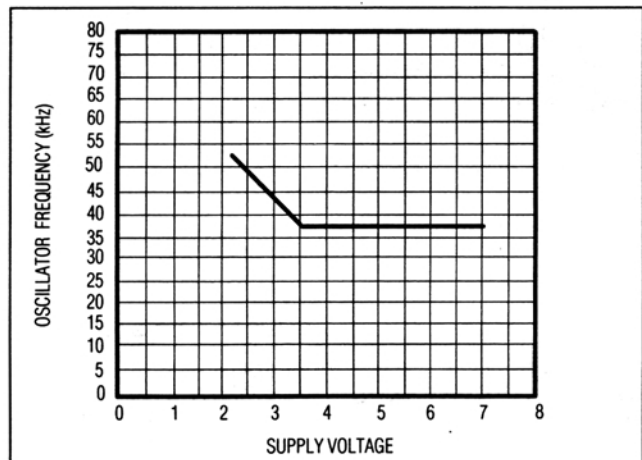

Figure 4B. MAX138/139/140 Typical Oscillator Frequency vs. Supply Voltage

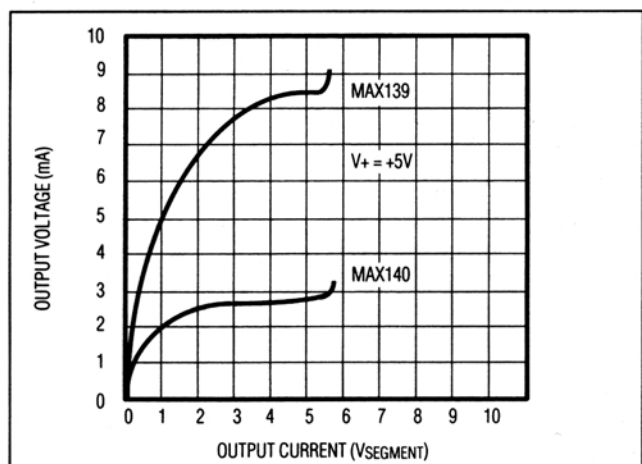

Figure 5. Output Current vs. Output Voltage

## Auto-Zero Capacitor

The noise of the ADC is influenced by the auto-zero capacitor. For the best noise performance, an auto-zero capacitor value of at least 4 times the integrator capacitor value is recommended. For a 2V scale, a 0.047µF (47nF) capacitor is adequate. An auto-zero capacitor of 0.47µF or greater is recommended for a 200mV full scale. All of Maxim's integrating ADCs have a zero-integrator phase which allows the use of high values for the auto-zero capacitor without causing hysteresis or slowing the overload recovery time.

The auto-zero capacitor can be any low-leakage film capacitor in most applications. A low-dielectric polypropylene capacitor is recommended if there are rapid changes in common-mode voltage, or if the ADC must rapidly stabilize upon power-up.

## Charge-Pump Capacitors

The charge-pump capacitors should be 1µF.

## Application Notes

### Common-Mode Voltage-Range Considerations

Operation with low supply voltages or with either IN LO or IN HI near either supply requires careful evaluation of the effect of common-mode voltages.

Since the MAX138/139/140 perform all conversion phases (including auto-zero and de-integration), using IN LO as the reference point results in an excellent normal-mode rejection of approximately 120dB.

There are three basic internal limitations on the allowable common-mode voltage (Figure 3):

- 1) The buffer input CMVR is (V- + 1.5V) to (V+ - 1.5V).
- 2) The integrator CMVR is (V- + 1.5V) to (V+ - 1.5V).
- 3) The integrator output swing is limited to V- to V+.
- 4) The IN LO must not go higher than 1.0V above COMMON.

Figure 3 shows the buffer input can be connected to either IN HI (IN LO +VREF) or (IN LO -VREF). The integrator noninverting input is always connected to IN LO.

Combining both system CMVR limitations with possible connections results in the limitations shown in Table 1.

## Low-Battery Detector

Since the voltage between COMMON and V+ is between +2.95V and +3.15V until the voltage between V+ and V- falls to less than +4V, a simple low-battery detector can be made using a transistor voltage detector as shown in Figure 6. When Q1 is off, the low-battery segment is driven in phase with the backplane off. When Q1 turns on, the low-battery LCD segment becomes visible. Q1 turns on when the voltage at the base of Q1 is one base-emitter voltage more positive than COMMON voltage.

# 3<sup>1</sup>/<sub>2</sub> Digit A/D Converters with Bandgap Reference and Charge-Pump Voltage Converter

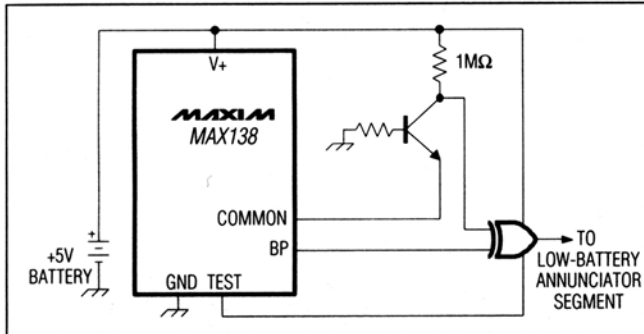

Figure 6. Low-Battery Detector and LCD Segment Drive

### Overload Display

The least significant three digits are blanked if the input voltage exceeds full scale. The leading "1" is displayed for positive overloads, and a "-1" is displayed for negative overloads. Any of the conditions that cause erratic readings (as discussed above) may cause overload readings. In addition, check the differential voltage between IN HI and IN LO to be sure it is no more than twice the differential voltage between REF HI and REF LO. Also be sure the voltage at REF HI is more positive than the voltage at REF LO since incorrect reference polarity causes an overload reading.

### Gross Nonlinearity

If the results are linear for low input voltages but stops increasing as higher input voltages are applied, saturation of the integrator output is the most likely cause. With a full-scale voltage applied, look at the voltage on INT. It should not come closer than 0.3V to either supply. Increase the integrator capacitor value if the INT output swing is excessive. Alternatively, increase the oscillator frequency by changing the oscillator resistor and capacitor values.

### Nonlinearities of 2 to 20 Counts

A polyester (Mylar) integrator capacitor will result in about 2 or 3 counts of nonlinearity at full scale. Use polypropylene for best linearity. Leakages into the integrator capacitor, the auto-zero capacitor, or the reference capacitor will also cause linearity errors. Make sure printed circuit boards are thoroughly cleaned after soldering.

### Gain Error and Rollover Error

A gross gain error will result if the integrator output current capabilities are exceeded. Make sure  $R_{INT} \geq V_{REF}/0.6\mu A$ .

Table 1. Common-Mode Voltage Limits

DEVICE	IN HI	IN LO	INTEGRATOR SWING
Positive Input Voltage	$V_- + 1.5V$ to $V_+ - 1.5V$	$V_- + (1.5V + V_{REF})$ to $V_+ - 1.5V$	(IN LO - V-)
Negative Input Voltage	$V_- + 1.5V$ to $V_+ - 1.5V$	$V_- + 1.5V$ to $V_+ - (1.5V + V_{REF})$	(V+ - IN LO)

Gain errors less than ten counts are generally caused by either too much stray capacitance on the CREF terminals or excessive printed circuit board leakage. Stray capacitance and leakage can be detected by reducing the reference-capacitor by a factor of ten. If the error dramatically increases, either stray capacitance or leakage at the reference-capacitor terminals is the culprit. Error caused by stray capacitance tends to be a pure gain error while errors due to leakage tend to be nonlinear (typically square law). Errors due to leakage can also be detected by cleaning the board and then baking to reduce moisture content.

### Missing Segments on the LCD Display

Missing segments on the LCD display is rarely a problem of the MAX138 and is usually caused by open circuits in the LCD connector/bezel, particularly if an elastomeric connector (zebra strip) is used. Check the voltage waveform at the pins of the MAX138. A signal in-phase with the backplane turns off an LCD segment, and a signal 180° out-of-phase from the backplane turns on an LCD segment.

### Troubleshooting Noisy Readings

The most common reason for noisy readings, particularly in engineering labs, is a noisy input signal. The 1MΩ/10nF input filter shown in Figures 1 and 2 will significantly reduce high-frequency noise, and the capacitor value can be increased to further attenuate 50/60Hz.

If the input signal is clean, check the integrator swing since low integrator swing will increase the noise. If the integrator swing must be reduced to less than 1V for some reason, increasing the value of the auto-zero capacitor will improve the noise performance. For most circuits, the integrator swing should be approximately ±2V.

A very low value for the auto-zero capacitor will also make the readings noisy. The value of the auto-zero capacitor should be at least twice the value of the integration capacitor. Increasing the auto-zero capacitor value to between 4 and 10 times that of the integrator capacitor will improve the noise performance, particularly with low-reference voltages.

Stray coupling of noise signals, either digital/microprocessor noise or 50/60Hz and 100/120Hz ripple can also be a cause of noisy readings. The auto-zero capacitor is most likely to pick up stray signals. The distance between the auto-zero capacitor and AZ should be minimized. The distance between the auto-zero capacitor and the integration resistor and capacitor should also be minimized. Since

# 3 1/2 Digit A/D Converters with Bandgap Reference and Charge-Pump Voltage Converter

BUFF and INT are the outputs of op amps, they are less sensitive to noise pickup than AZ, the input of an op amp.

The MAX138/139/140 are sensitive to AC noise at IN LO during the de-integrate phase. Full-wave AC-DC converters should be used only if both outputs of the AC-DC converter output are well filtered.

The common output on the MAX138/139/140 is derived from a bandgap reference that results in noisier common outputs than the ICL7106 and ICL7136 which are derived from zeners. This could cause an increase in conversion noise, but only if the CREF is less than 0.1µF and there is no bypassing at the reference inputs.

Poor bypassing of the supply voltage may cause a couple of counts of noise in the readings, particularly if the power supply also powers digital logic since high-frequency spikes on the power supply might cause the comparator to falsely indicate zero crossing one or two clock cycles early. Ordinary 0.1µF bypass capacitors are adequate in most cases. Since the MAX138/139/140 draw very little current, a simple RC filter can be used to provide greater spike and ripple attenuation in those cases where the power supply is exceptionally noisy.

Since the oscillator frequency is slightly affected by the supply voltage, large changes in the supply voltage during a conversion may cause a few counts of error. A typical case where the effect must be considered is in a battery-powered circuit where the battery is also being used to drive high-current loads, such as motors or lamps. For extreme cases where high-current loads momentarily change the battery voltage a volt or more, use a series diode and a capacitor of 10µF or greater.

## Application Hints

1. See the ICL7136 and ICL7106 data sheets for a variety of application circuits that can also be used with the MAX138/139/140.
2. In some applications it may be useful to apply a fixed reference voltage between IN HI and IN LO and to apply the signal to REF HI and REF LO. In this mode of operation, the displayed reading is inversely proportional to the input voltage. In other words, the displayed reading is the result of *dividing* the fixed reference voltage by the signal voltage. A typical application where this function is useful is in a RPM meter where a voltage proportional to the period of a signal is divided into a fixed voltage to convert period into RPM (frequency). Another example is in a conductance meter where the conversion between ohms and Siemens is performed by swapping the positions of the unknown and reference resistors.
3. A serial-output pulse stream can be obtained from the MAX138/139/140 by monitoring the voltage at the

CREF terminals (Figure 23 in the ICL7106 data sheet). Use an AND gate to combine the resulting end-of-conversion signal with the oscillator output from OSC3.

4. If the input-signal polarity is reversed from the desired polarity, use the minus segment to drive the vertical bar of a plus sign and (using one of the decimal-point driver circuits of Figure 6) to permanently turn on the horizontal bar of the plus sign. When the MAX138/139/140 measures a negative polarity, a "+" will be displayed. When the MAX138/139 measures a positive polarity, a "-" will be displayed. (Normal operation of the MAX138/139/140 is no polarity indication for a positive input and a "-" sign for a negative input.)

## Pin Configurations (continued)

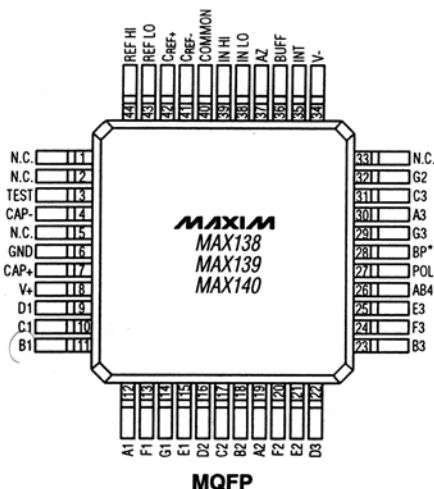
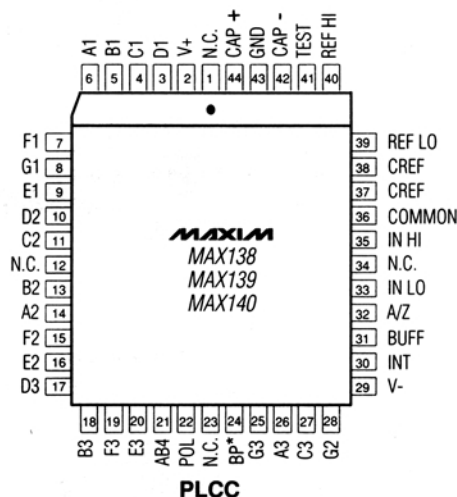

\* Note: BP (MAX138)  
DIGITAL GND (MAX139/140) N.C. = No Connect

Maxim cannot assume responsibility for use of any circuitry other than circuitry entirely embodied in a Maxim product. No circuit patent licenses are implied. Maxim reserves the right to change the circuitry and specifications without notice at any time.

## Looking for pricing, stock, or lifecycle information?

Click below to explore more details on WIN SOURCE:

 [View MAX138CMH+ on WIN SOURCE](#)

 [Maxim Integrated](#) Information

## Optimize Your Supply Chain with WIN SOURCE Solutions

-  Global Sourcing Solution
-  Obsolete Management
-  Cost Control Management
-  Shortage Management
-  Alternative Solution
-  Excess Inventory Management