



**THE DATASHEET OF  
MAX14575AETA+T**



# MAX14575A/MAX14575AL/ MAX14575B/MAX14575C

## 250mA to 2.5A Adjustable Current-Limit Switches

### General Description

The MAX14575A/MAX14575AL/MAX14575B/MAX14575C programmable current-limit switches feature internal current limiting to prevent damage to host devices due to faulty load conditions. These current-limit switches feature a low 32mΩ (typ) on-resistance and operate from a +2.3V to +5.5V input voltage range. The current limit is adjustable from 250mA to 2.5A, making these devices ideal for charging a large load capacitor as well as for high-current load switching applications.

Each device in the family handles an overcurrent event differently depending on the option selected. The MAX14575A/MAX14575AL feature an autoretry mode, the MAX14575A has active high, and the MAX14575AL has active-low EN polarity. The MAX14575B has latch-off mode, and the MAX14575C features a continuous current-limit mode. Additional safety features include thermal shutdown protection to prevent overheating and reverse current blocking to prevent current from being driven back into the source (see the *Selector Guide*).

The MAX14575A/MAX14575AL/MAX14575B/MAX14575C are available in a small 8-pin, 2mm x 2mm TDFN package and operate over the -40°C to +85°C extended temperature range.

### Benefits and Features

- ◆ **Integrated Protection Reduces Board Space and Makes Systems More Robust**
  - ±10% Overload Current Limit (500mA to 2.5A)
  - Reverse-Current Protection
  - 1μA (max) Shutdown Reverse Current
  - Short-Circuit Protection
  - Thermal Shutdown Protection
- ◆ **Low Power Dissipation Reduces Heat and/or Battery Consumption**
  - 130μA (typ) Low Supply Current
  - 32mΩ (typ) Low RON
- ◆ **Flexible Part Can Easily Be Reused In Multiple Projects**
  - Adjustable Current Limit (250mA to 2500mA)
  - +2.3V to +5.5V Supply Voltage Range

### Applications

RF Power Amplifier in Cell Phones	Portable Media Players UTCA/ATCA Platforms
USB Ports	SDXC Card Power-Supply Protection
Data Modem Cards	

### Ordering Information/Selector Guide

PART	PIN-PACKAGE	TEMP RANGE	EN POLARITY	OVERCURRENT RESPONSE	TOP MARK
MAX14575AETA+T	8 TDFN-EP*	-40°C to +85°C	Active-High	Autoretry	BMV
MAX14575ALETA+T	8 TDFN-EP*	-40°C to +85°C	Active-Low	Autoretry	BMW
MAX14575BETA+T	8 TDFN-EP*	-40°C to +85°C	Active-High	Latch-off	BMX
MAX14575CETA+T	8 TDFN-EP*	-40°C to +85°C	Active-High	Continuous	BMV

+Denotes a lead(Pb)-free/RoHS-compliant package.

T = Tape and reel.

\*EP = Exposed pad.

### Typical Operating Circuit

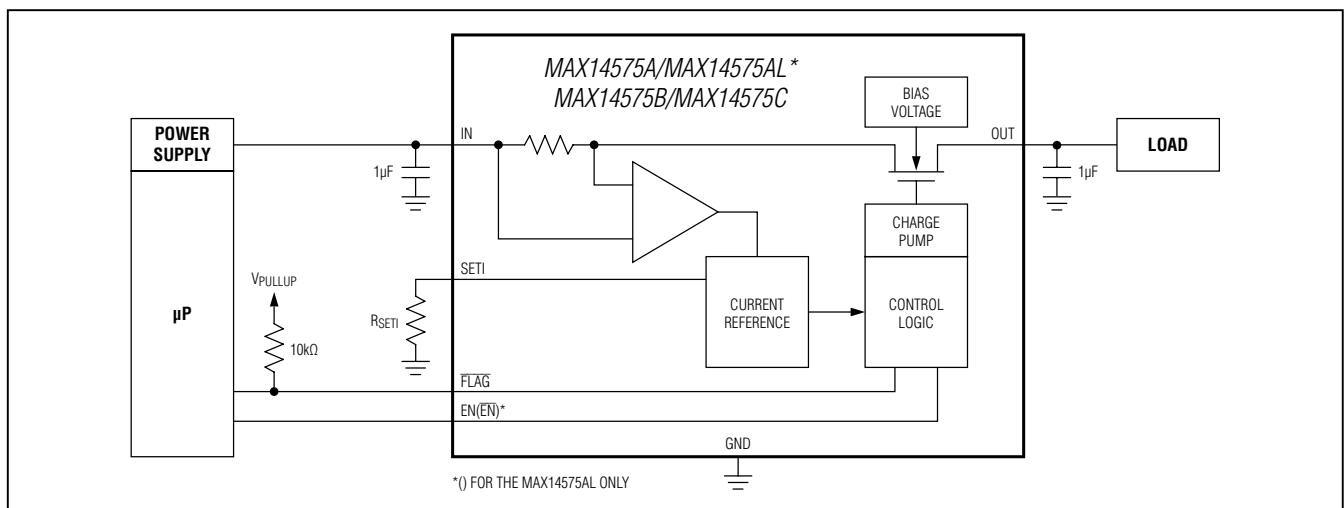

# MAX14575A/MAX14575AL/ MAX14575B/MAX14575C

## 250mA to 2.5A Adjustable Current-Limit Switches

### ABSOLUTE MAXIMUM RATINGS

(Voltages referenced to GND.)

IN, EN,  $\overline{\text{EN}}$ ,  $\overline{\text{FLAG}}$ , OUT, and SETI to GND ..... -0.3V to +6V  
 Current into Any Pin (Except IN, OUT) .....  $\pm 20\text{mA}$   
 OUT Short Circuit to GND ..... Internally Limited  
 Continuous Power Dissipation ( $T_A = +70^\circ\text{C}$ )  
 TDFN (derate 11.9mW/ $^\circ\text{C}$  above  $+70^\circ\text{C}$ ) ..... 954mW

Operating Temperature Range .....  $-40^\circ\text{C}$  to  $+85^\circ\text{C}$   
 Storage Temperature Range .....  $-65^\circ\text{C}$  to  $+150^\circ\text{C}$   
 Junction Temperature .....  $+150^\circ\text{C}$   
 Lead Temperature (soldering, 10s) .....  $+300^\circ\text{C}$   
 Soldering Temperature (reflow) .....  $+260^\circ\text{C}$

Stresses beyond those listed under "Absolute Maximum Ratings" may cause permanent damage to the device. These are stress ratings only, and functional operation of the device at these or any other conditions beyond those indicated in the operational sections of the specifications is not implied. Exposure to absolute maximum rating conditions for extended periods may affect device reliability.

### PACKAGE THERMAL CHARACTERISTICS (Note 1)

TDFN

Junction-to-Ambient Thermal Resistance ( $\theta_{JA}$ ) .....  $+83.9^\circ\text{C}/\text{W}$   
 Junction-to-Case Thermal Resistance ( $\theta_{JC}$ ) .....  $+37^\circ\text{C}/\text{W}$

**Note 1:** Package thermal resistances were obtained using the method described in JEDEC specification JESD51-7, using a four-layer board. For detailed information on package thermal considerations, refer to [www.maximintegrated.com/thermal-tutorial](http://www.maximintegrated.com/thermal-tutorial).

### ELECTRICAL CHARACTERISTICS

( $V_{IN} = +2.3\text{V}$  to  $+5.5\text{V}$  and  $T_A = -40^\circ\text{C}$  to  $+85^\circ\text{C}$ , unless otherwise noted. Typical values are at  $V_{IN} = +3.3\text{V}$ ,  $C_{IN} = 1\mu\text{F}$ ,  $C_{OUT} = 1\mu\text{F}$ ,  $R_{SETI} = 100\text{k}\Omega$ ,  $T_A = +25^\circ\text{C}$ .) (Note 2)

PARAMETER	SYMBOL	CONDITIONS	MIN	TYP	MAX	UNITS
<b>SUPPLY OPERATION</b>						
Operating Voltage	$V_{IN}$		2.3		5.5	V
Quiescent Current	$I_Q$	$I_{OUT} = 0\text{A}$ , switch on, $V_{IN} = 3.3\text{V}$ , $R_{SETI} = 560\text{k}\Omega$		130	275	$\mu\text{A}$
Latchoff Current	$I_{LATCH}$	$I_{OUT} = 0\text{A}$ , after an overcurrent fault (MAX14575B)		6	20	$\mu\text{A}$
Shutdown Forward Current	$I_{SHDN}$	$V_{EN} = 0\text{V}$ , $V_{\overline{\text{EN}}} = 5.5\text{V}$ , $V_{IN} = 5.5\text{V}$ , $V_{OUT} = 0\text{V}$		0.1	3.5	$\mu\text{A}$
Shutdown Reverse Current	$I_{RSHDN}$	$V_{EN} = 0\text{V}$ , $V_{\overline{\text{EN}}} = 5.5\text{V}$ , $V_{IN} = 0\text{V}$ , $V_{OUT} = 5.5\text{V}$ (current into OUT)		0.07	1	$\mu\text{A}$
<b>INTERNAL FET</b>						
Switch On-Resistance	$R_{ON}$	$V_{IN} = 5.5\text{V}$ , $T_A = +25^\circ\text{C}$ , $I_{OUT} = 100\text{mA}$ , $I_{OUT} < I_{LIM}$		32	50	$\text{m}\Omega$
Forward Current Limit	$I_{LIM}$	$R_{SETI} = 52.65\text{k}\Omega$	2250	2500	2750	mA
		$R_{SETI} = 268.7\text{k}\Omega$	450	500	550	
		$R_{SETI} = 538.7\text{k}\Omega$	200	250	300	
$R_{SETI}$ Coefficient	P	$I_{LIM} = 0.5\text{A}$ to $2.5\text{A}$		135		kV
$R_{SETI}$ Constant	C	$I_{LIM} = 0.5\text{A}$ to $2.5\text{A}$		1.35		$\text{k}\Omega$
Reverse Blocking Current		$V_{OUT} > V_{IN} + 145\text{mV}$ , after reverse current-limit shutdown			2	$\mu\text{A}$
Reverse Blocking Threshold	$V_{OUT} - V_{IN}$	$V_{OUT} - V_{IN} = 300\text{mV}$ , OUT falling until switch turns on, while measuring $V_{OUT} - V_{IN}$	25	100	145	mV
$\overline{\text{FLAG}}$ Assertion Drop Voltage Threshold	VFA	Increase ( $V_{IN} - V_{OUT}$ ) drop until $\overline{\text{FLAG}}$ asserts, in current-limit mode, $V_{IN} = 3.3\text{V}$ , $R_{SETI} = \text{unconnected}$		345		mV

# MAX14575A/MAX14575AL/ MAX14575B/MAX14575C

## 250mA to 2.5A Adjustable Current-Limit Switches

### ELECTRICAL CHARACTERISTICS (continued)

( $V_{IN} = +2.3V$  to  $+5.5V$  and  $T_A = -40^{\circ}C$  to  $+85^{\circ}C$ , unless otherwise noted. Typical values are at  $V_{IN} = +3.3V$ ,  $C_{IN} = 1\mu F$ ,  $C_{OUT} = 1\mu F$ ,  $R_{SET1} = 100k\Omega$ ,  $T_A = +25^{\circ}C$ .) (Note 2)

PARAMETER	SYMBOL	CONDITIONS	MIN	TYP	MAX	UNITS
<b>EN, <math>\overline{EN}</math> INPUT</b>						
EN, $\overline{EN}$ Input Leakage	$I_{LEAK}$	EN, $\overline{EN} = IN$ or GND	-1		+1	$\mu A$
EN, $\overline{EN}$ Input Logic-High Voltage	$V_{IH}$		1.6			V
EN, $\overline{EN}$ Input Logic-Low Voltage	$V_{IL}$				0.4	V
<b>FLAG OUTPUT</b>						
FLAG Output Logic-Low Voltage		$I_{SINK} = 1mA$			0.4	V
FLAG Output Leakage Current		$V_{IN} = V_{FLAG} = 5.5V$ , FLAG deasserted			1	$\mu A$
<b>TIMING CHARACTERISTICS</b>						
Turn-On Time	$t_{SS}$	Time from ENABLE signal to $V_{OUT} = 90\%$ of $V_{IN}$ , Figure 1		600		$\mu s$
Turn-Off Time	$t_{OFF}$	Time from DISABLE signal to $V_{OUT} = 10\%$ of $V_{IN}$ , $R_L = 1k\Omega$ , $C_{OUT} = 0$ , Figure 1		100		$\mu s$
Current-Limit Reaction Time	$t_{LIM}$	Output high and then short circuit applied		3		$\mu s$
Blanking Time	$t_{BLANK}$	Figures 2 and 3 (Note 3)	10	15	25	ms
Retry Time	$t_{RETRY}$	MAX14575A/MAX14575AL Figure 2 (Note 3)	320	500	875	ms
<b>THERMAL PROTECTION</b>						
Thermal Shutdown				+160		$^{\circ}C$
Thermal Shutdown Hysteresis				20		$^{\circ}C$

**Note 2:** All devices are 100% production tested at  $T_A = +25^{\circ}C$ . Limits over the operating temperature range are guaranteed by design; not production tested.

**Note 3:** Blanking time and retry time are generated by the same internal oscillator. The ratio of  $\frac{t_{RETRY}}{t_{BLANK}}$  is a constant value of 32.

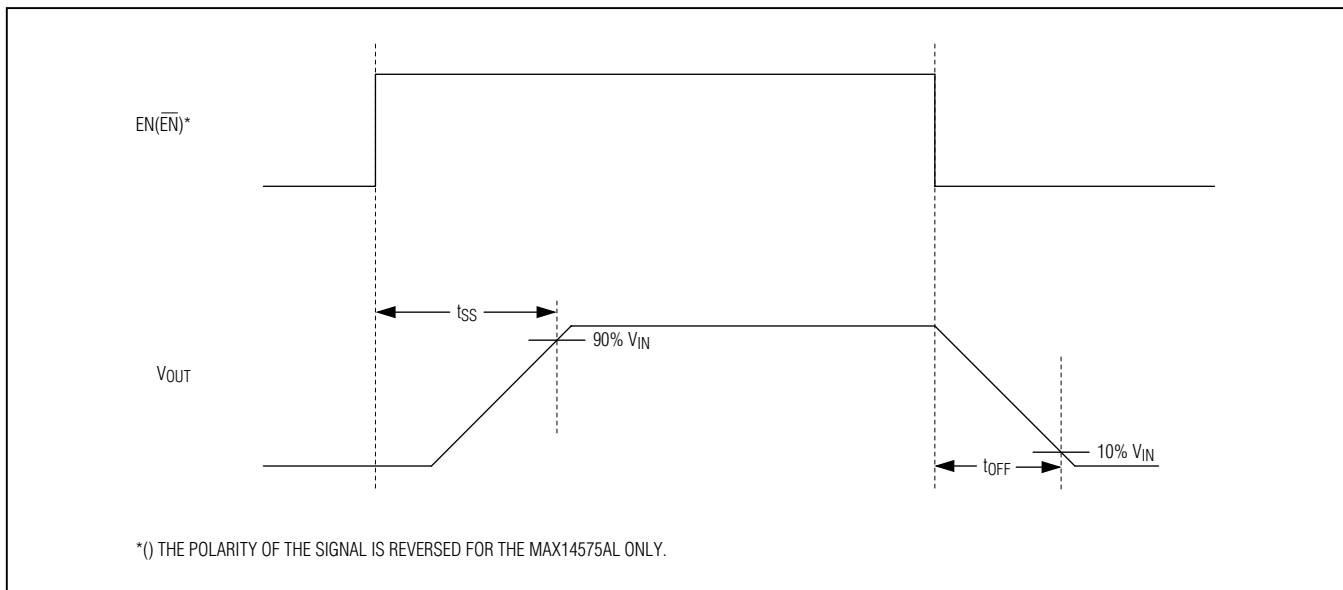

Figure 1. Timing Diagram for Measuring Turn-On Time ( $t_{SS}$ ) and Turn-Off Time ( $t_{OFF}$ ).

# MAX14575A/MAX14575AL/ MAX14575B/MAX14575C

## 250mA to 2.5A Adjustable Current-Limit Switches

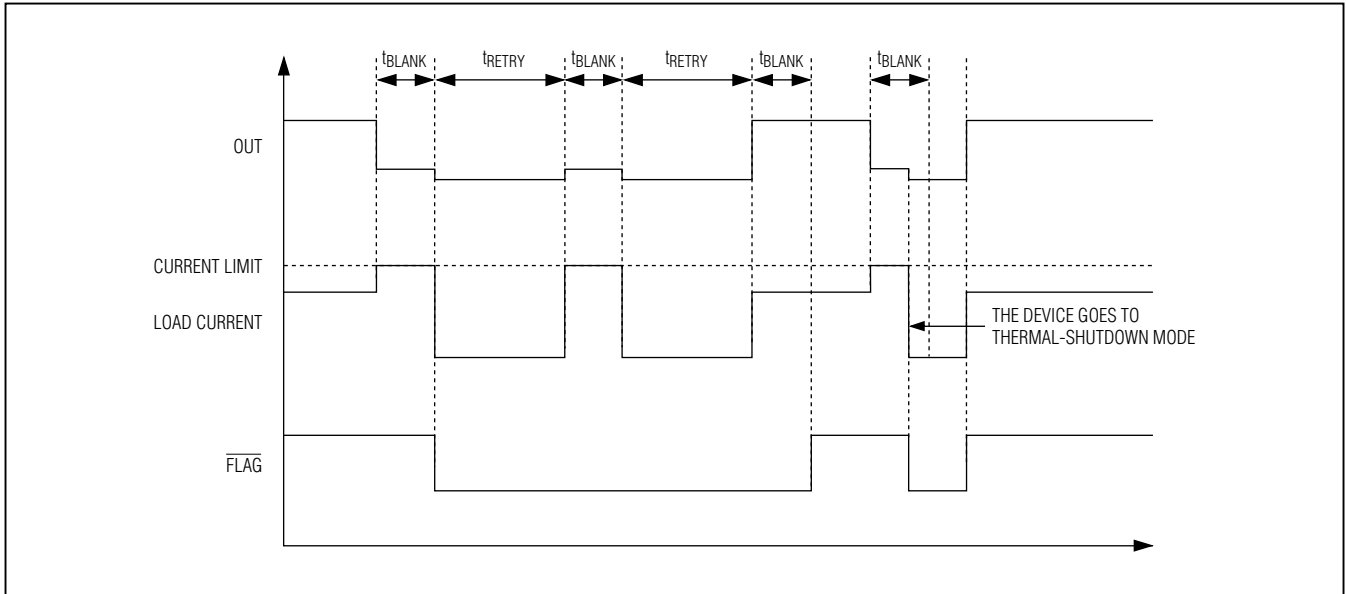

Figure 2. Autoretry Fault Diagram

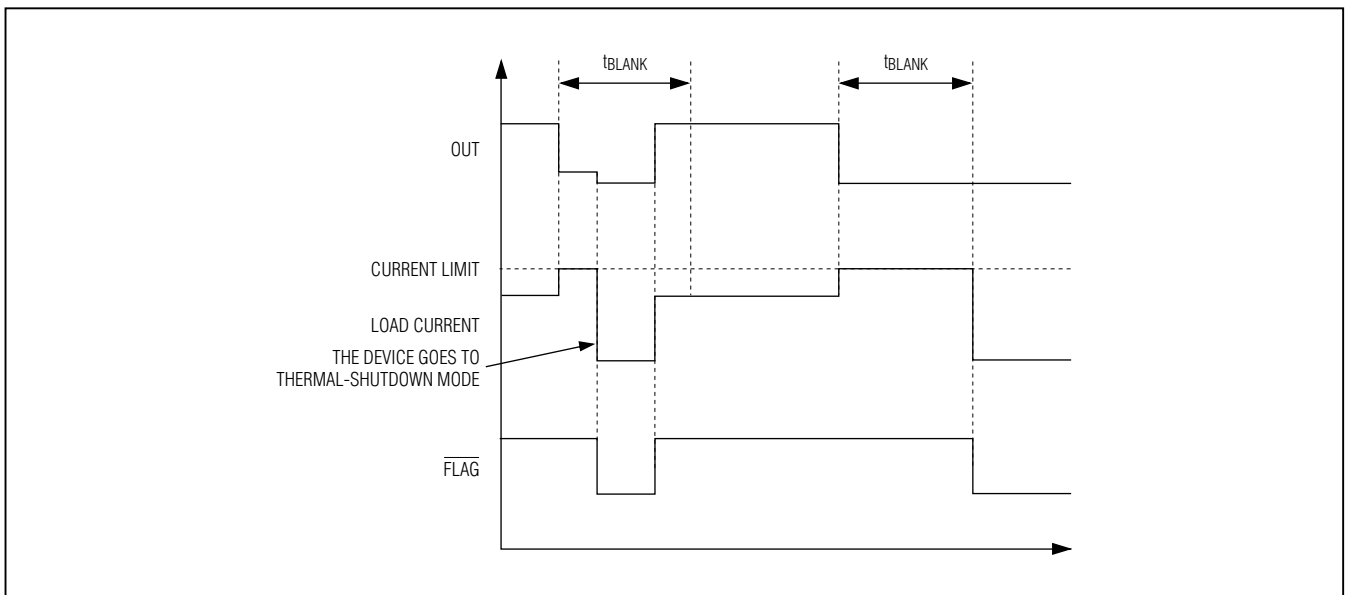

Figure 3. Latchoff Fault Diagram

# MAX14575A/MAX14575AL/ MAX14575B/MAX14575C

## 250mA to 2.5A Adjustable Current-Limit Switches

### Typical Operating Characteristics

( $V_{IN} = +3.3V$ ,  $C_{IN} = 1\mu F$ ,  $C_{OUT} = 1\mu F$ ,  $R_{SET1} = 94.2k\Omega$ ,  $T_A = +25^\circ C$ , unless otherwise noted.)

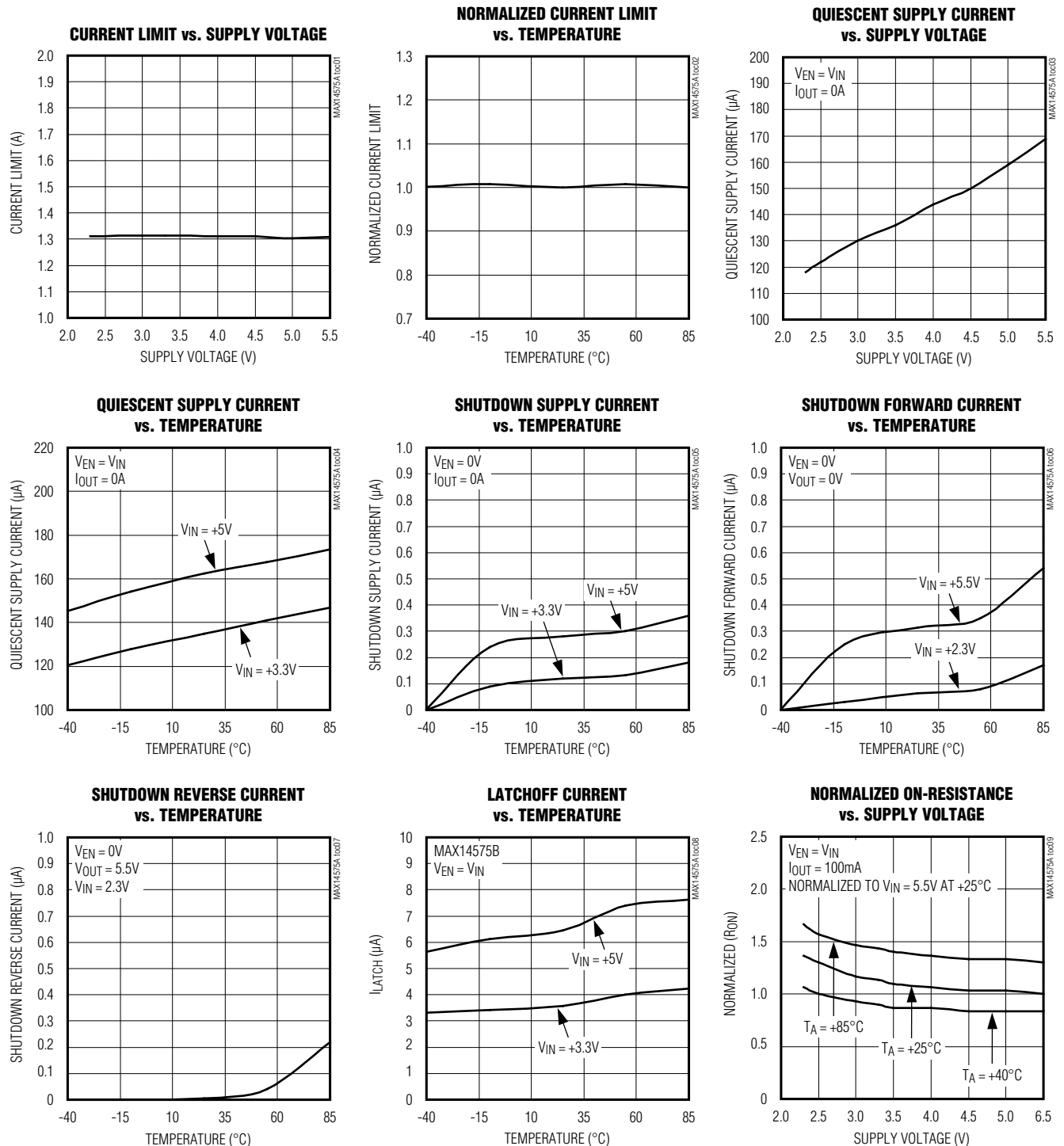

# MAX14575A/MAX14575AL/ MAX14575B/MAX14575C

## 250mA to 2.5A Adjustable Current-Limit Switches

### Typical Operating Characteristics (continued)

( $V_{IN} = +3.3V$ ,  $C_{IN} = 1\mu F$ ,  $C_{OUT} = 1\mu F$ ,  $R_{SET1} = 94.2k\Omega$ ,  $T_A = +25^\circ C$ , unless otherwise noted.)

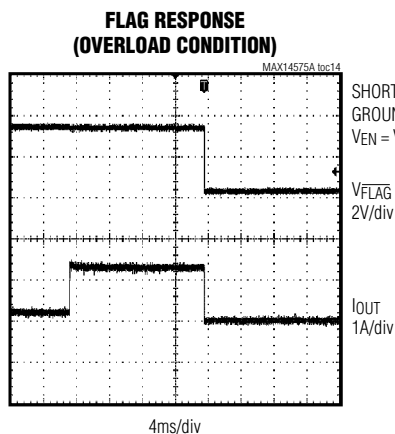
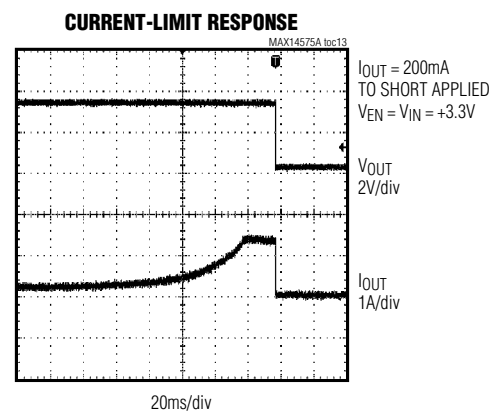
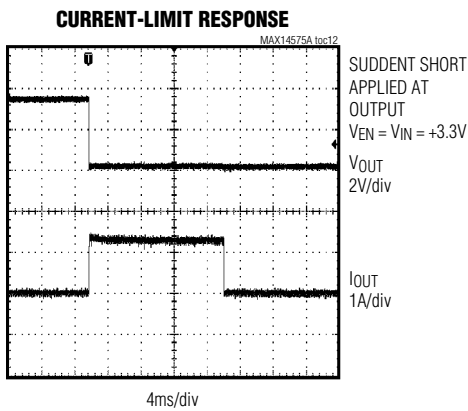
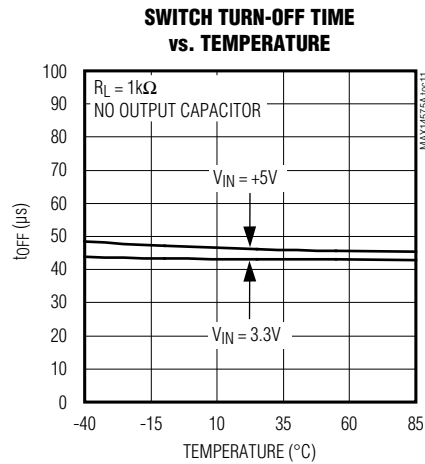
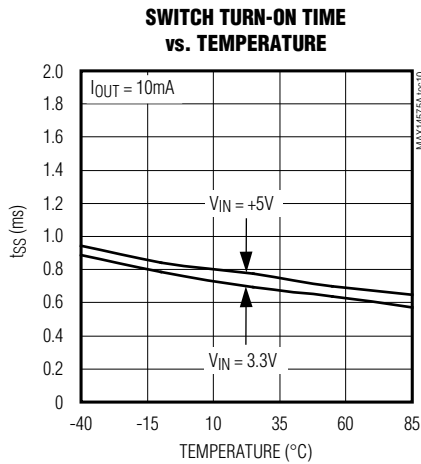

# MAX14575A/MAX14575AL/ MAX14575B/MAX14575C

## 250mA to 2.5A Adjustable Current-Limit Switches

### Pin Configuration

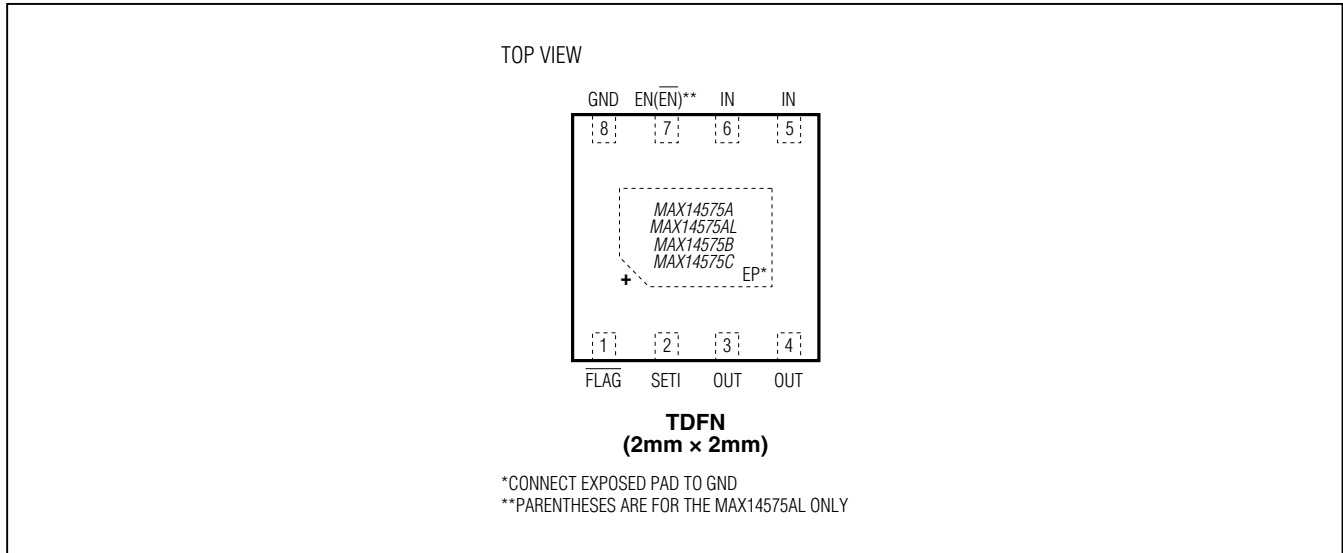

### Pin Description

PIN		NAME	FUNCTION
MAX14575AL	MAX14575_		
1	1	$\overline{\text{FLAG}}$	Open-Drain Overcurrent Indicator Output. $\overline{\text{FLAG}}$ goes low when the overload fault duration exceeds the blanking time, reverse current is detected, thermal shutdown mode is active, or SETI is connected to ground.
2	2	SETI	Forward Current-Limit Adjust Input. Connect a resistor from SETI to GND to program the overcurrent limit. If SETI is connected to GND, the switch turns off and FLAG is asserted. Do not leave SETI unconnected or connect any capacitor larger than 20pF to SETI.
3, 4	3, 4	OUT	Switch Output. Connect OUT pins 3 and 4 together and bypass OUT to GND with a 1 $\mu$ F ceramic capacitor as close to the device as possible.
5, 6	5, 6	IN	Power Input. Connect IN pins 5 and 6 together and bypass IN to GND with a 1 $\mu$ F ceramic capacitor as close to the device as possible. If necessary, use higher capacitance to prevent large load transients from pulling down the supply voltage.
7	—	$\overline{\text{EN}}$	Active-Low Enable Input. Drive $\overline{\text{EN}}$ low to turn on the switch. Drive $\overline{\text{EN}}$ high to turn off the switch.
—	7	EN	Active-High Enable Input. Drive EN high to turn on the switch. Drive EN low to turn off the switch.
8	8	GND	Ground
—	—	EP	Exposed Pad. Internally connected to GND. Connect to a large ground plane to maximize thermal performance. Not intended as an electrical connection point.

# MAX14575A/MAX14575AL/ MAX14575B/MAX14575C

## 250mA to 2.5A Adjustable Current-Limit Switches

### Functional Diagram

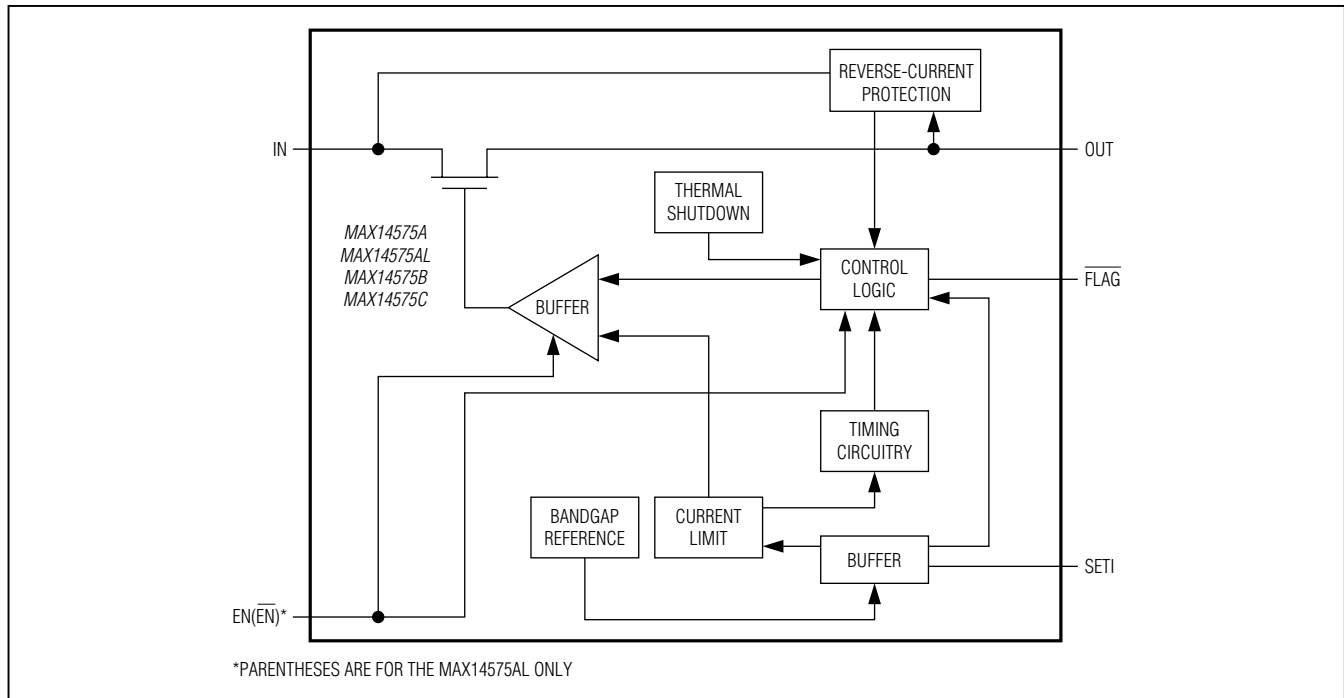

### Detailed Description

The MAX14575A/MAX14575AL/MAX14575B/MAX14575C programmable current-limit switches operate from +2.3V to +5.5V and provide internal current limiting adjustable from 250mA to 2.5A. These devices feature a fixed blanking time and a  $\overline{\text{FLAG}}$  output that notifies the processor when a fault condition is present.

#### Programmable Current-Limit Threshold

A resistor from SET1 to GND sets the current-limit threshold for the switch (see the *Setting the Current-Limit Threshold* section). If the output current is limited at the current threshold value for a time equal to or longer than  $t_{\text{BLANK}}$  with  $V_{\text{IN}} - V_{\text{OUT}}$  higher than the  $\overline{\text{FLAG}}$  assertion drop voltage threshold ( $V_{\text{FA}}$ ), then the  $\overline{\text{FLAG}}$  asserts, and the MAX14575A/MAX14575AL enter the autoretry mode, the MAX14575B latches off the switch, and the MAX14575C enters the continuous current-limit mode.

#### Autoretry (MAX14575A/MAX14575AL)

When the forward current reaches the current threshold, the  $t_{\text{BLANK}}$  timer begins counting (Figure 2).  $\overline{\text{FLAG}}$  asserts if the overcurrent condition is present for  $t_{\text{BLANK}}$ . The timer resets if the overcurrent condition disappears

before the blanking time ( $t_{\text{BLANK}}$ ) has elapsed. A retry time delay ( $t_{\text{RETRY}}$ ) starts immediately after the blanking time has elapsed and during that time, the switch latches off. At the end of  $t_{\text{RETRY}}$ , the switch turns on again. If the fault still exists, the cycle repeats. If the fault has been removed, the switch stays on. During this cycle,  $\overline{\text{FLAG}}$  stays low. In autoretry, if the die temperature exceeds +160°C (typ) due to self-heating, the MAX14575A/MAX14575AL go into thermal-shutdown mode until the die temperature drops by approximately 20°C.

The autoretry feature saves system power in case of an overcurrent or short-circuit condition. During  $t_{\text{BLANK}}$  time, when the switch is on, the supply current is held at the current limit. During time  $t_{\text{RETRY}}$ , when the switch is off, the current through the switch is zero. Thus, the average output current is much less than the programmed current limit. Calculate the average output current using the following equation:

$$I_{\text{LOAD}} = I_{\text{LIM}} \times \frac{t_{\text{BLANK}}}{t_{\text{BLANK}} + t_{\text{RETRY}}}$$

For example, if  $t_{\text{BLANK}} = 15\text{ms}$  and  $t_{\text{RETRY}} = 500\text{ms}$ , the duty cycle is 3%, resulting in a 97% power savings over the switch being on the entire time.

# MAX14575A/MAX14575AL/ MAX14575B/MAX14575C

## 250mA to 2.5A Adjustable Current-Limit Switches

### Latchoff (MAX14575B)

When the forward current reaches the current threshold, the tBLANK timer begins counting (Figure 3). FLAG asserts if an overcurrent condition is present for greater than tBLANK time. The timer resets if the overcurrent condition disappears before tBLANK has elapsed. The switch turns off if the overcurrent condition continues beyond the blanking time. Reset the switch by either toggling the control logic (EN) or cycling the input voltage. If the die temperature exceeds +160°C (typ) due to self-heating, the MAX14575B goes into thermal-shutdown mode until the die temperature drops by approximately 20°C.

### Continuous Current Limit (MAX14575C)

When the forward current reaches the forward-current threshold, the MAX14575C limits the output current to the programmed current limit. FLAG asserts if the current limit is present for tBLANK and deasserts when the overload condition is removed. In this mode, if the die temperature exceeds +160°C (typ) due to self-heating, the MAX14575C goes into thermal-shutdown mode until the die temperature drops by approximately 20°C.

### Switch Enable Control (EN/EN)

The EN input for the MAX14575A/B/C and EN input for the MAX14575AL control the internal switch. See Table 1.

### Reverse Current Protection

The MAX14575A/MAX14575AL/MAX14575B/MAX14575C feature a reverse current protection circuit that limits the backflow current to 2µA when the reverse current protection circuitry has tripped. The switch turns off and FLAG asserts without waiting for tBLANK to elapse. The switch turns back on and FLAG deasserts when VOUT - VIN drops below the reverse blocking threshold.

### FLAG Indicator

FLAG is an open-drain fault indicator output and requires an external pullup resistor to a DC supply. FLAG goes low when any of the following conditions occur:

- An overcurrent condition after the blanking time has elapsed and  $V_{IN} - V_{OUT} > V_{FA}$

**Table 1. Switch Truth Table**

MAX14575A/B/C	MAX14575AL	SWITCH STATUS
EN	EN	
0	1	OFF
1	0	ON

- The reverse current protection has tripped
- The die temperature exceeds +160°C
- SETI is connected to ground

### Thermal Shutdown

Thermal shutdown circuitry protects the devices from overheating. The switch turns off and FLAG goes low immediately when the junction temperature exceeds +160°C (typ). The MAX14575A/AL/C switches turn on again after the device temperature drops by approximately 20°C (typ).

## Applications Information

### Setting the Current-Limit Threshold

Connect a resistor between SETI and ground to program the current-limit threshold value for the MAX14575A/MAX14575AL/MAX14575B/MAX14575C. Table 2 shows current-limit thresholds for different resistor values at SETI. Connecting SETI to ground asserts FLAG.

Use the following formula to calculate the current limit:

$$R_{SETI}(k\Omega) = \frac{P(kV)}{I_{LIM}(A)} - C(k\Omega)$$

Do not use an RSETI value smaller than 40kΩ.

Note: Connecting any capacitor larger than 20pF to SETI can cause instability.

**Table 2. Current-Limit Threshold vs. Resistor Values**

RSETI (kΩ)	CURRENT LIMIT (A)
510	0.26
470	0.28
402	0.33
301	0.45
261	0.51
200	0.625
150	0.86
100	1.32
90	1.45
85	1.55
75	1.75
64	2.02
57.6	2.26
53	2.5

# MAX14575A/MAX14575AL/ MAX14575B/MAX14575C

## 250mA to 2.5A Adjustable Current-Limit Switches

### IN Bypass Capacitor

Connect a minimum 1µF capacitor from IN to GND to limit the input-voltage drop during momentary output short-circuit conditions. If the power supply cannot support the required short-circuit current, then a larger capacitor should be used to maintain the input voltage above 2.3V.

If the supply is not strong enough and the user does not want to use a larger capacitor at the input, then the following circuitry can be used (Figure 4.)

### OUT Bypass Capacitor

For stable operation over the full temperature range and over the full programmable current-limit range, use a 1µF ceramic capacitor from OUT to ground.

Excessive output capacitance can cause a false over-current condition due to decreased dV/dt across the capacitor. Use the following formula to calculate the maximum capacitive load (C<sub>MAX</sub>) on OUT:

$$C_{MAX}(\mu F) = \frac{I_{LIM}(mA) \times t_{BLANK}(MIN)(ms)}{V_{IN}(V)}$$

For example, for V<sub>IN</sub> = 5.0V, t<sub>BLANK</sub> = 10ms, and I<sub>LIM</sub> = 1000mA, C<sub>MAX</sub> equals 2000µF.

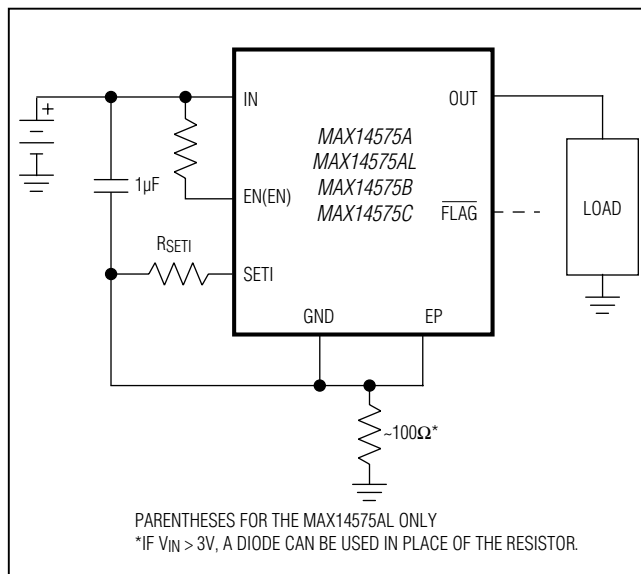

Figure 4. Optional Protection for Weak Supply

### Layout and Thermal Dissipation

To optimize the switch response time to output short-circuit conditions, it is very important to keep all traces as short as possible to reduce the effect of undesirable parasitic inductance. Place input and output capacitors as close as possible to the device (should be no more than 5mm). IN and OUT must be connected with wide short traces to the power bus. During normal operation, the power dissipation is small and the package temperature change is minimal. If the output is continuously shorted to ground at the maximum supply voltage, the operation of the switches with the autoretry option does not cause problems because the total power dissipated during the short is scaled by the duty cycle:

$$P_{(MAX)} = \frac{V_{IN(MAX)} \times I_{OUT(MAX)} \times t_{BLANK}}{t_{RETRY} + t_{BLANK}}$$

Attention must be given to the MAX14575C continuous current-limit version when the power dissipation during a fault condition causes the device to reach the thermal-shutdown threshold.

### Chip Information

PROCESS: BiCMOS

### Package Information

For the latest package outline information and land patterns (footprints), go to [www.maximintegrated.com/packages](http://www.maximintegrated.com/packages). Note that a "+", "#", or "-" in the package code indicates RoHS status only. Package drawings may show a different suffix character, but the drawing pertains to the package regardless of RoHS status.

PACKAGE TYPE	PACKAGE CODE	OUTLINE NO.	LAND PATTERN NO.
8 TDFN-EP	T822+2	<a href="#">21-0168</a>	<a href="#">90-0065</a>

# **MAX14575A/MAX14575AL/ MAX14575B/MAX14575C 250mA to 2.5A Adjustable Current-Limit Switches**

## **Revision History**

<b>REVISION NUMBER</b>	<b>REVISION DATE</b>	<b>DESCRIPTION</b>	<b>PAGES CHANGED</b>
0	9/12	Initial release	—
1	9/14	Removed $R_{SET1} \times I_{LIM}$ line in <i>Electrical Characteristics Table</i> Corrected the unit of $I_{LIM}$ in $R_{SET1}$ calculation	2, 11
2	1/15	Updated <i>Benefits and Features</i> section	1



Maxim Integrated cannot assume responsibility for use of any circuitry other than circuitry entirely embodied in a Maxim Integrated product. No circuit patent licenses are implied. Maxim Integrated reserves the right to change the circuitry and specifications without notice at any time. The parametric values (min and max limits) shown in the Electrical Characteristics table are guaranteed. Other parametric values quoted in this data sheet are provided for guidance.

**Maxim Integrated 160 Rio Robles, San Jose, CA 95134 USA 1-408-601-1000**

11

## Looking for pricing, stock, or lifecycle information?

Click below to explore more details on WIN SOURCE:

-  View [MAX14575AETA+T](#) on WIN SOURCE
-  [Maxim Integrated](#) Information

## Optimize Your Supply Chain with WIN SOURCE Solutions

-  Global Sourcing Solution
-  Obsolete Management
-  Cost Control Management
-  Shortage Management
-  Alternative Solution
-  Excess Inventory Management