



THE DATASHEET OF MAX3058ASA+T





5V, 1Mbps, Low Supply Current CAN Transceivers

MAX3058/MAX3059

General Description

The MAX3058/MAX3059 interface between the controller area network (CAN) protocol controller and the physical wires of the bus lines in a CAN. They are primarily intended for printer and telecom backplane applications requiring data rates up to 1Mbps. These devices provide differential transmit capability to the bus and differential receive capability to the CAN controller.

The MAX3058 output common-mode range is from -7V to +12V. The MAX3059 output common-mode range is from 0V to V_{CC}. The MAX3059 contains an internal switch termination resistor that makes it ideal for JetLink applications.

The MAX3058 features four different modes of operation: high speed, slope control, standby, and shutdown. The MAX3059 features three different modes of operation: high speed, slope control, and shutdown. High-speed mode allows data rates up to 1Mbps. In slope-control mode, the slew rate may be optimized for data rates up to 500kbps, so the effects of EMI are reduced, and unshielded twisted or parallel cable can be used. In standby mode, the transmitters are shut off and the receivers are put into low-current mode. In shutdown mode, the transmitter and receiver are switched off.

The MAX3058/MAX3059 are available in an 8-pin SO package and are specified over the -40°C to +125°C temperature range.

Applications

- Printers JetLink
- Industrial Control Networks
- Telecom Backplane
- Consumer Applications

Features

- ◆ Four Operating Modes
 - High-Speed Operation Up to 1Mbps
 - Slope-Control Mode to Reduce EMI (40kbps to 500kbps)
 - Low-Current Shutdown Mode
 - Standby Mode (MAX3058 Only)
- ◆ Thermal Shutdown
- ◆ Current Limiting
- ◆ ESD Protection
 - ±12kV Human Body Model

Ordering Information

PART	TEMP RANGE	PIN-PACKAGE
MAX3058ASA	-40°C to +125°C	8 SO
MAX3059ASA	-40°C to +125°C	8 SO

Selector Guide

PART	TERMINATION RESISTOR	STANDBY
MAX3058ASA	No	Yes
MAX3059ASA	Yes	No

Pin Configurations

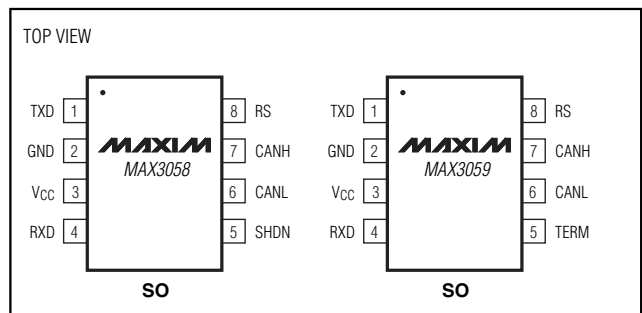

Typical Operating Circuit appears at end of data sheet.



5V, 1Mbps, Low Supply Current CAN Transceivers

ABSOLUTE MAXIMUM RATINGS

V _{CC} to GND	-0.3V to +6V	Continuous Power Dissipation (T _A = +70°C)
TXD, RS, SHDN, TERM to GND.....	-0.3V to +6V	8-Pin SO (derate 5.9mW/°C above +70°C).....
RXD to GND	-0.3V to +6V	470mW
CANH, CANL to GND (MAX3058)	-7.5V to +12.5V	Operating Temperature Range
CANH, CANL to GND (MAX3059).....	-0.3V to (V _{CC} + 0.3V)	-40°C to +125°C
		Maximum Junction Temperature
		+150°C
		Storage Temperature Range
		-65°C to +150°C
		Lead Temperature (soldering, 10s)
		+300°C

Stresses beyond those listed under "Absolute Maximum Ratings" may cause permanent damage to the device. These are stress ratings only, and functional operation of the device at these or any other conditions beyond those indicated in the operational sections of the specifications is not implied. Exposure to absolute maximum rating conditions for extended periods may affect device reliability.

DC ELECTRICAL CHARACTERISTICS

(V_{CC} = +5V ±10%, T_A = T_{MIN} to T_{MAX}, R_L = 60Ω, C_L = 100pF. Typical values are at V_{CC} = +5V and T_A = +25°C.) (Note 1)

PARAMETER	SYMBOL	CONDITIONS	MIN	TYP	MAX	UNITS
Supply Current	I _S	Dominant		40	70	mA
		Recessive		2	5	
Quiescent Current Standby Mode	I _Q	Standby, MAX3058		15	80	μA
Shutdown Current	I _{SHDN}	V _{SHDN} = V _{CC} , MAX3058			5	μA
		V _{TERM} = V _{RS} = V _{CC} , MAX3059			10	
		V _{TERM} = 0V, V _{RS} = V _{CC} , MAX3059			150	
Thermal-Shutdown Threshold	V _{TSH}			160		°C
Thermal-Shutdown Hysteresis				25		°C
TXD INPUT LEVELS						
High-Level Input Voltage	V _{IH}		2			V
Low-Level Input Voltage	V _{IL}				0.8	V
Input Capacitance	C _{IN}	(Note 3)		5	20	pF
Pullup Resistor	R _{INTXD}		50		100	kΩ
TERM INPUT LEVELS (MAX3059)						
High-Level Input Voltage	V _{TRH}		2			V
Low-Level Input Voltage	V _{TRL}				0.8	V
TERM Pullup Resistor	R _{PU}		50		100	kΩ
CANH, CANL TRANSMITTER						
Recessive Bus Voltage	V _{CANH} , V _{CANL}	V _{TXD} = V _{CC} , no load	2		3	V
		V _{TXD} = V _{CC} , no load, V _{RS} = V _{CC} (standby mode), MAX3058	-100		+100	mV
CANH Output Voltage	V _{CANH}	V _{TXD} = 0V	2.75		V _{CC} - 0.8V	V
CANL Output Voltage	V _{CANL}	V _{TXD} = 0V	0.5		2.25	V
Differential Output (V _{CANH} - V _{CANL})	ΔV _{CANH} , V _{CANL}	V _{TXD} = 0V, V _{CC} = 5V ±5%	1.5		3	V
		V _{TXD} = 0V, V _{CC} = 5V ±10%	1.5		3.2	
		V _{TXD} = 0V, R _L = 45Ω	1.2		3	
		V _{TXD} = V _{CC} , no load	-500		+50	mV

5V, 1Mbps, Low Supply Current CAN Transceivers

MAX3058/MAX3059

DC ELECTRICAL CHARACTERISTICS (continued)

($V_{CC} = +5V \pm 10\%$, $T_A = T_{MIN}$ to T_{MAX} , $R_L = 60\Omega$, $C_L = 100pF$. Typical values are at $V_{CC} = +5V$ and $T_A = +25^\circ C$.) (Note 1)

PARAMETER	SYMBOL	CONDITIONS	MIN	TYP	MAX	UNITS
CANH Short-Circuit Current	I_{CANHSC}	$-7V \leq V_{CANH} \leq 0V$, MAX3058	-200		-30	mA
		$V_{CANH} = 0V$, MAX3059	-200		-30	
CANL Short-Circuit Current	I_{CANLSC}	$V_{CC} \leq V_{CANL} \leq 12V$, MAX3058	30		200	mA
		$V_{CANL} = V_{CC}$, MAX3059	30		200	
Termination Resistor	R_{TERM}	$V_{TERM} = V_{CC}$, MAX3059	108	120	132	Ω
RXD OUTPUT LEVELS						
RXD High-Output Voltage Level	V_{OH}	$I = -100\mu A$	$0.8 \times V_{CC}$		V_{CC}	V
RXD Low-Output Voltage Level	V_{OL}	$I = 1.6mA$			0.4	V
DC BUS RECEIVER (Note 2)						
Differential Input Voltage (Recessive)	V_{DIFF}	MAX3058	-17		+0.5	V
		MAX3058, $V_{RS} = V_{CC}$ (standby mode)	-17		+0.5	
		MAX3059	$-V_{CC}$		+0.5	
Differential Input Voltage (Dominant)	V_{DIFF}	MAX3058	0.9		17	V
		MAX3058, $V_{RS} = V_{CC}$ (standby mode)	1.1		17	
		MAX3059	0.9		V_{CC}	
Differential Input Hysteresis	$V_{DIFF(HYST)}$			100		mV
CANH and CANL Input Resistance	R_I		5		25	$k\Omega$
Differential Input Resistance	R_{DIFF}		10		100	$k\Omega$
MODE SELECTION (RS)						
Input Voltage for High Speed	V_{SLP}				$0.3 \times V_{CC}$	V
Input Voltage for Standby	V_{STBY}	MAX3058	$0.75 \times V_{CC}$			V
	V_{SHDN}	MAX3059				
Slope-Control Mode Voltage	V_{SLOPE}	$R_{RS} = 25k\Omega$ to $200k\Omega$	$0.4 \times V_{CC}$		$0.6 \times V_{CC}$	V
Slope-Control Mode Current	I_{SLOPE}	$R_{RS} = 25k\Omega$ to $200k\Omega$	-10		-200	μA
High-Speed Mode Current	I_{HS}	$V_{RS} = 0V$			-500	μA
SHUTDOWN (MAX3058)						
SHDN Input Voltage High	V_{SHDNH}		2			V
SHDN Input Voltage Low	V_{SHDNL}				0.8	V
SHDN Pulldown Resistor	R_{INDHDN}		50		100	$k\Omega$

5V, 1Mbps, Low Supply Current CAN Transceivers

TIMING CHARACTERISTICS

($V_{CC} = +5V \pm 10\%$, $R_L = 60\Omega$, $C_L = 100pF$, $T_A = T_{MIN}$ to T_{MAX} . Typical values are at $V_{CC} = +5V$ and $T_A = +25^\circ C$.)

PARAMETER	SYMBOL	CONDITIONS	MIN	TYP	MAX	UNITS
Delay TXD to Bus Active, Figure 1	t_{ONTXD}	$V_{RS} = 0V (\leq 1Mbps)$			50	ns
		$R_{RS} = 25k\Omega (\leq 500kbps)$		125		
		$R_{RS} = 100k\Omega (\leq 125kbps)$		450		
		$R_{RS} = 200k\Omega (\leq 62.5kbps)$		700		
Delay TXD to Bus Inactive, Figure 1	t_{OFFTXD}	$V_{RS} = 0V (\leq 1Mbps)$			70	ns
		$R_{RS} = 25k\Omega (\leq 500kbps)$		180		
		$R_{RS} = 100k\Omega (\leq 125kbps)$		500		
		$R_{RS} = 200k\Omega (\leq 62.5kbps)$		1000		
Delay Bus to Receiver Active, Figure 1	t_{ONRXD}	$V_{RS} = 0V (\leq 1Mbps)$			80	ns
		$R_{RS} = 25k\Omega (\leq 500kbps)$		150		
		$R_{RS} = 100k\Omega (\leq 125kbps)$		500		
		$R_{RS} = 200k\Omega (\leq 62.5kbps)$		800		
Delay Bus to Receiver Inactive, Figure 1	t_{OFFRXD}	$V_{RS} = 0V (\leq 1Mbps)$			100	ns
		$R_{RS} = 25k\Omega (\leq 500kbps)$		210		
		$R_{RS} = 100k\Omega (\leq 125kbps)$		500		
		$R_{RS} = 200k\Omega (\leq 62.5kbps)$		1100		
Differential Output Slew Rate	SR	$V_{RS} = 0V (\leq 1Mbps)$		100		$V/\mu s$
		$R_{RS} = 25k\Omega (\leq 500kbps)$		7		
		$R_{RS} = 100k\Omega (\leq 125kbps)$		1.6		
		$R_{RS} = 200k\Omega (\leq 62.5kbps)$		0.8		
Bus Dominant to RXD Active	t_{DRXDL}	$V_{RS} > 0.8 \times V_{CC}$ (standby), MAX3058, Figure 2			1	μs
Standby to Receiver Active	t_{SBRXDL}	BUS dominant, MAX3058, Figure 2			4	μs
SHDN to Bus Inactive	$t_{OFFSHDN}$	TXD = GND, MAX3058, Figure 3 (Note 4)			1	μs
SHDN to Receiver Active	t_{ONSHDN}	BUS dominant, MAX3058, Figure 3 (Note 5)			4	μs
RS to Bus Inactive	$t_{OFFSHDN}$	TXD = GND, MAX3059, Figure 3 (Note 4)			1	μs
RS to Receiver Active	t_{ONSHDN}	BUS dominant, MAX3059, Figure 3 (Note 5)			4	μs
TERM to Resistor Switched On	t_{ONRT}	$V_{RS} = V_{CC}$ (part in shutdown), MAX3059, Figure 4			400	ns
TERM to Resistor Switched Off	t_{OFFRT}	$V_{RS} = V_{CC}$ (part in shutdown), MAX3059, Figure 4			400	ns
ESD Protection		Human Body Model		12		$\pm kV$

Note 1: All currents into device are positive; all currents out of the device are negative. All voltages are referenced to device ground, unless otherwise noted.

Note 2: ($V_{TXD} = V_{CC}$; CANH and CANL externally driven; $-7V < V_{CANH}$, $V_{CANL} < 12V$ for MAX3058; $0V < V_{CANH}$, $V_{CANL} < V_{CC}$ for MAX3059, unless otherwise specified).

Note 3: Specification guaranteed by design, not production tested.

Note 4: No other devices on the BUS.

Note 5: BUS externally driven.

5V, 1Mbps, Low Supply Current CAN Transceivers

Timing Diagrams

MAX3058/MAX3059

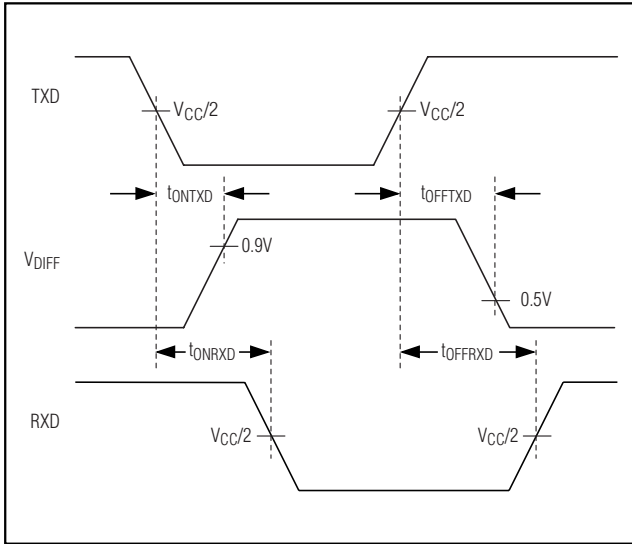

Figure 1. Timing Diagram

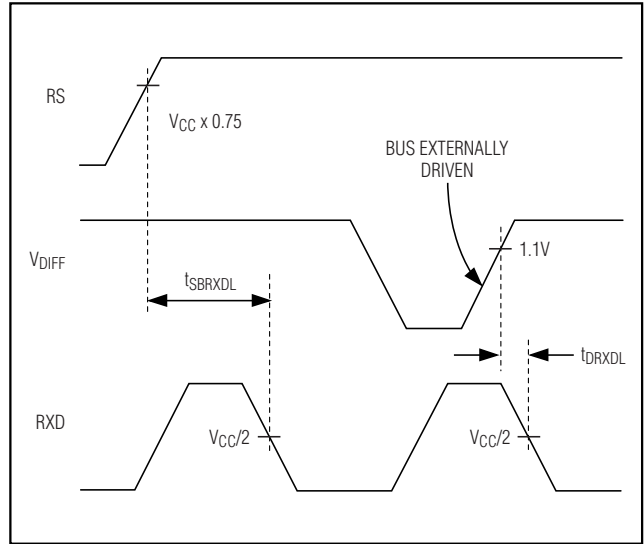

Figure 2. Timing Diagram for Standby Signal (MAX3058)

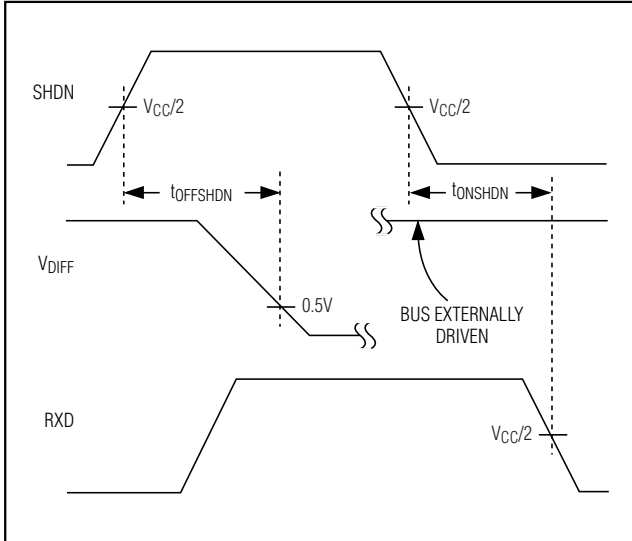

Figure 3. Timing Diagram for Shutdown Signal

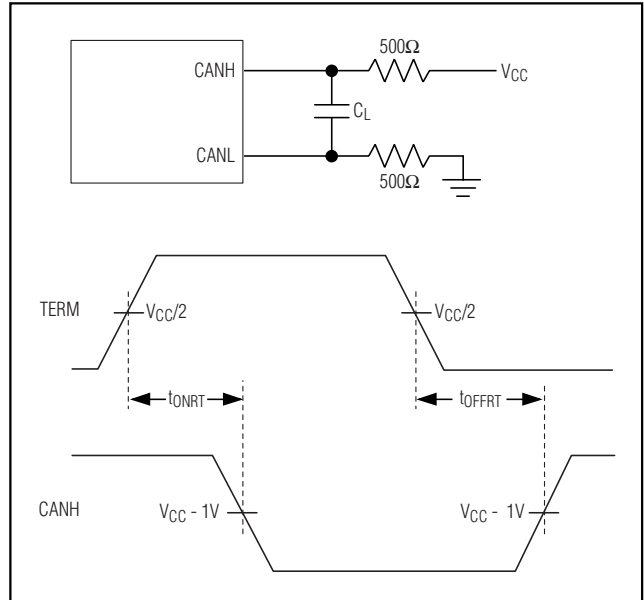
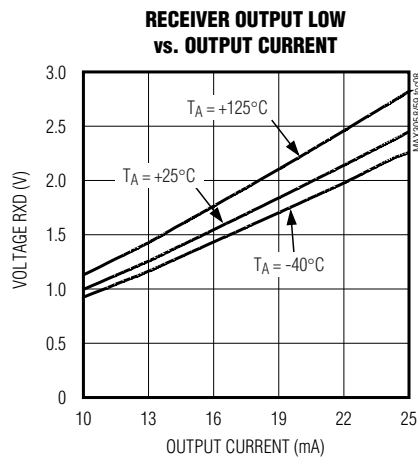
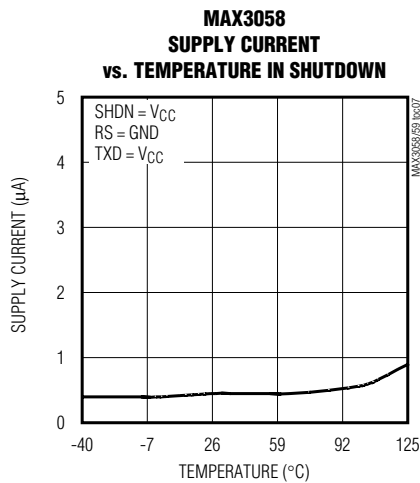
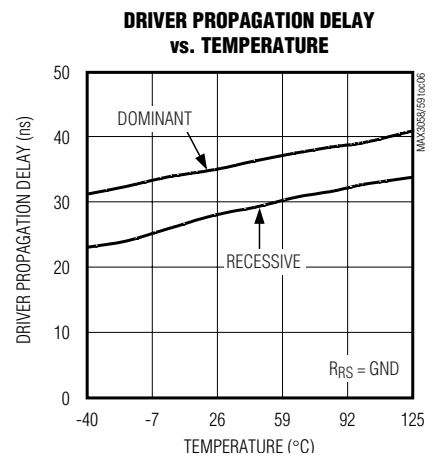
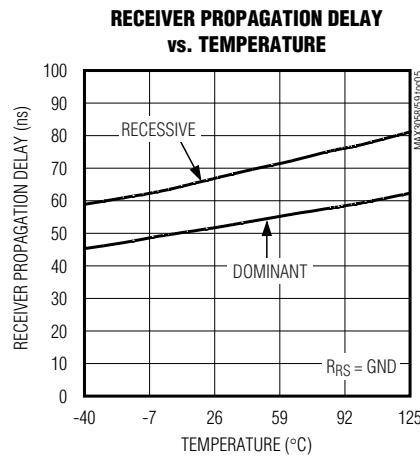
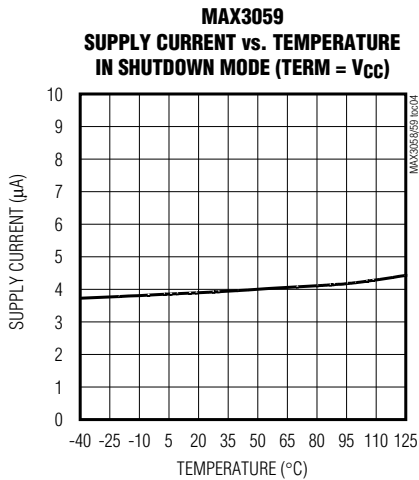
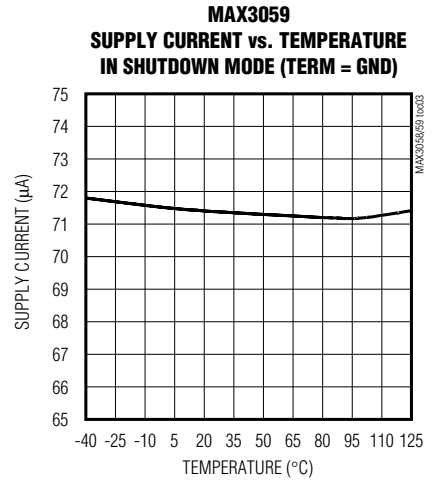
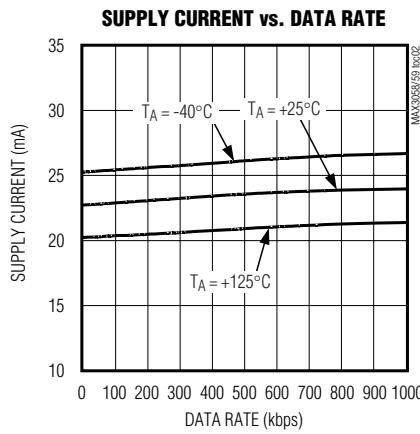
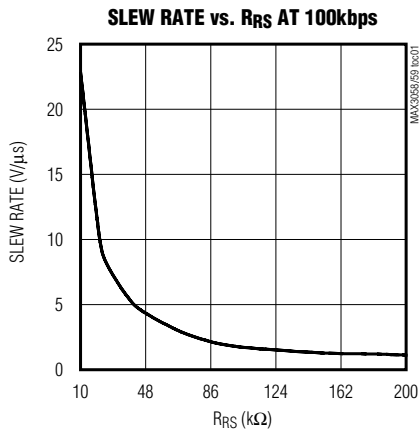

Figure 4. Test Circuit and Diagram for TERM Timing (MAX3059)

5V, 1Mbps, Low Supply Current CAN Transceivers

Typical Operating Characteristics

($V_{CC} = +5V$, $R_L = 60\Omega$, $C_L = 100pF$, $T_A = +25^\circ C$, unless otherwise specified.)



5V, 1Mbps, Low Supply Current CAN Transceivers

MAX3058/MAX3059

Typical Operating Characteristics (continued)

($V_{CC} = +5V$, $R_L = 60\Omega$, $C_L = 100pF$, $T_A = +25^\circ C$, unless otherwise specified.)

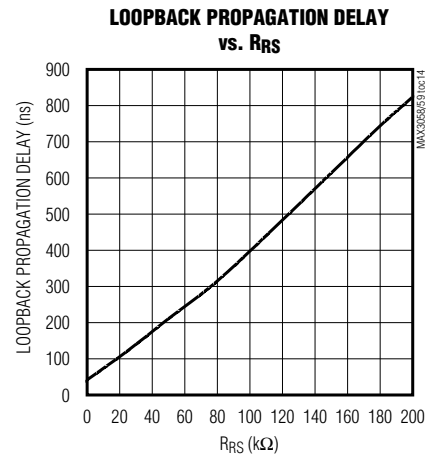
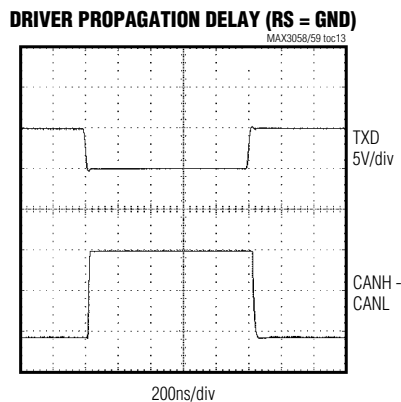
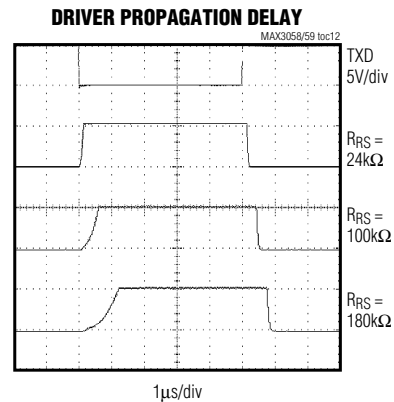
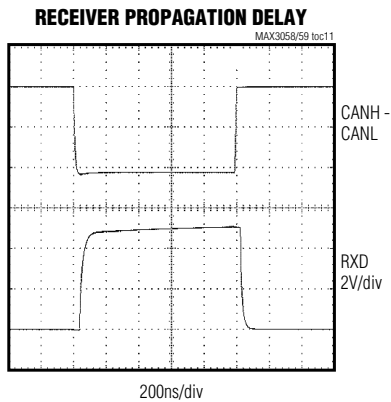
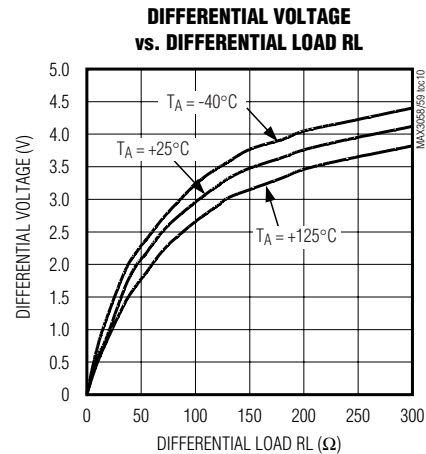
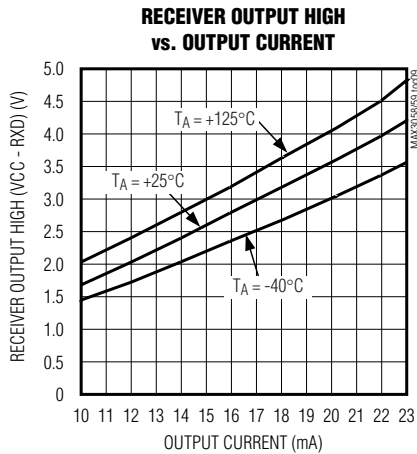

5V, 1Mbps, Low Supply Current CAN Transceivers

Pin Description

PIN		NAME	FUNCTION
MAX3058	MAX3059		
1	1	TXD	Transmit Data Input. TXD is a CMOS/TTL-compatible input from a CAN controller. TXD has an internal 75kΩ pullup resistor.
2	2	GND	Ground
3	3	V _{CC}	Supply Voltage. Bypass V _{CC} to GND with a 0.1μF capacitor.
4	4	RXD	Receive Data Output. RXD is a CMOS/TTL-compatible output.
5	—	SHDN	Shutdown Input, CMOS/TTL-Compatible Input. Drive SHDN high to put the IC into shutdown mode. SHDN has an internal 75kΩ pulldown resistor to GND.
6	6	CANL	CAN Bus Line Low
7	7	CANH	CAN Bus Line High
8	8	RS	Mode Select Input. Drive RS low or connect to GND for high-speed operation. Connect a resistor between RS and GND to control output slope. For the MAX3058, drive RS high to put into standby mode. (see <i>Mode Selection</i> section). For the MAX3059, drive RS above 0.75 x V _{CC} to select shutdown mode.
—	5	TERM	Terminate Input, CMOS/TTL Compatible. Drive TERM high or leave floating to terminate the device with a 120Ω across the CANH and CANL. Drive TERM low to disconnect this resistor. TERM has an internal 75kΩ pullup resistor to V _{CC} .

Functional Diagram

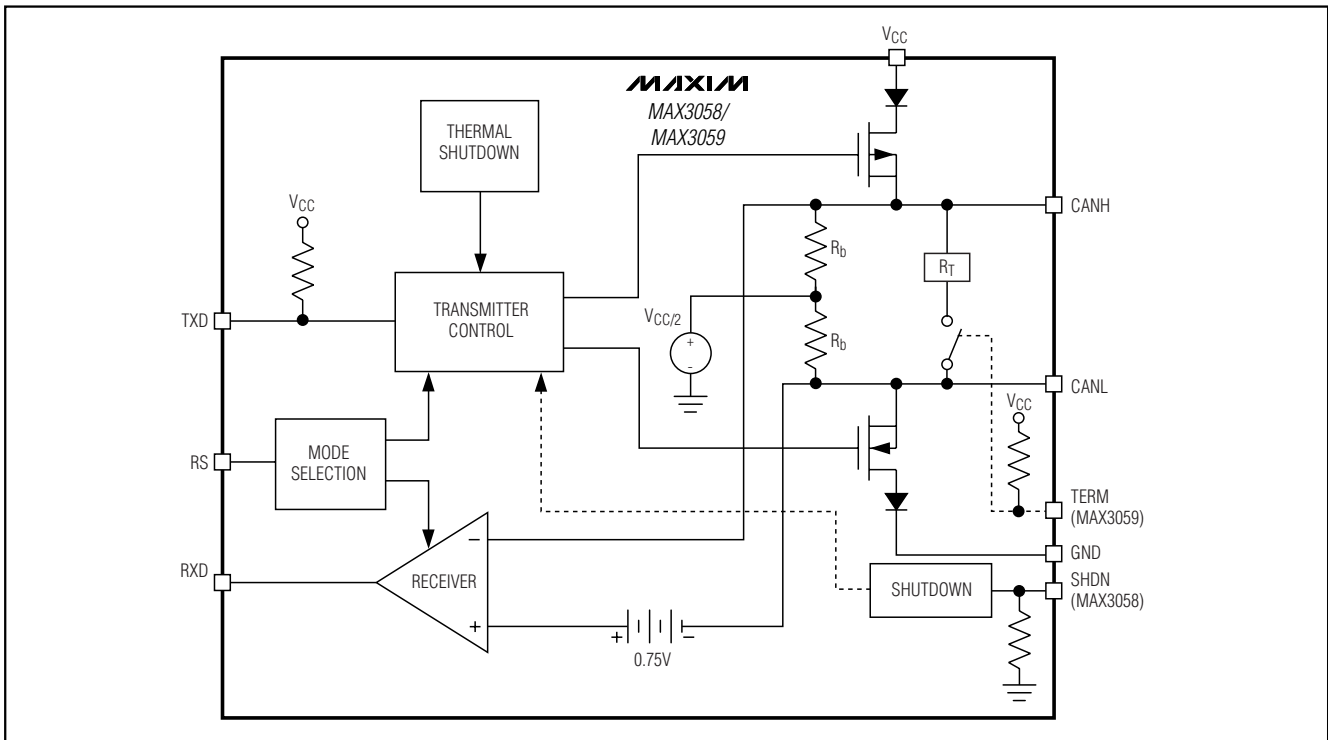

5V, 1Mbps, Low Supply Current CAN Transceivers

MAX3058/MAX3059

Detailed Description

The MAX3058/MAX3059 interface between the protocol controller and the physical wires of the bus lines in a CAN. They are primarily intended for printer and telecom backplane applications requiring data rates up to 1Mbps. These devices provide differential transmit capability to the bus and differential receive capability to the CAN controller.

The MAX3058 output common-mode range is from -7V to +12V. The MAX3059 output common-mode range is from 0V to V_{CC} . The MAX3059 contains an internal switch termination resistor that makes it ideal for JetLink applications.

The MAX3058 features four different modes of operation: high-speed, slope control, standby, and shutdown. The MAX3059 features three different modes of operation: high speed, slope control, and shutdown. High-speed mode allows data rates up to 1Mbps. In slope-control mode, the slew rate may be optimized for data rates up to 500kbps, so the effects of EMI are reduced, and unshielded twisted or parallel cable can

be used. In standby mode, the transmitters are shut off and the receivers are put into low-current mode. In shutdown mode, the transmitter and receiver are switched off.

The transceivers operate from a single +5V supply and draw 40mA of supply current in dominant state and 2mA in recessive state. In standby mode, supply current is reduced to 15 μ A. In shutdown mode, supply current is 1 μ A for the MAX3058 and 5 μ A for the MAX3059.

CANH and CANL are output short-circuit current limited and are protected against excessive power dissipation by thermal-shutdown circuitry that places the driver outputs into a high-impedance state.

Transmitter

The transmitter converts a single-ended input (TXD) from the CAN controller to differential outputs for the bus lines (CANH, CANL). The truth table for the transmitter and receiver is given in Tables 1 and 2.

Table 1. Transmitter and Receiver Truth Table for MAX3058 When Not Connected to the Bus

TXD	RS	SHDN	CANH	CANL	BUS STATE	RXD
Low	$V_{RS} < 0.75 \times V_{CC}$	Low	High	Low	Dominant	Low
High or float	$V_{RS} < 0.75 \times V_{CC}$	Low	5k Ω to 25k Ω to $V_{CC}/2$	5k Ω to 25k Ω to $V_{CC}/2$	Recessive	High
X	$V_{RS} > 0.75 \times V_{CC}$	Low	5k Ω to 25k Ω to GND	5k Ω to 25k Ω to GND	Recessive	High
X	X	High	Floating	Floating	Floating	High

Table 2. Transmitter and Receiver Truth Table for MAX3059 When Not Connected to the Bus

TXD	RS	TERM	CANH	CANL	BUS STATE	RXD
Low	$V_{RS} < 0.75 \times V_{CC}$	Low	High	Low	Dominant	Low
Low	$V_{RS} < 0.75 \times V_{CC}$	High	High	Low	Dominant	Low
			120 Ω terminating resistor across			
High or float	$V_{RS} < 0.75 \times V_{CC}$	Low	5k Ω to 25k Ω to $V_{CC}/2$	5k Ω to 25k Ω to $V_{CC}/2$	Recessive	High
High or float	$V_{RS} < 0.75 \times V_{CC}$	High	5k Ω to 25k Ω to $V_{CC}/2$	5k Ω to 25k Ω to $V_{CC}/2$	Recessive	High
			120 Ω terminating resistor across			
X	$V_{RS} > 0.75 \times V_{CC}$	Low	Floating	Floating	Floating	High
X	$V_{RS} > 0.75 \times V_{CC}$	High	Floating	Floating	Floating	High
			120 Ω terminating resistor across			

5V, 1Mbps, Low Supply Current CAN Transceivers

Receiver

The receiver reads differential input from the bus lines (CANH, CANL) and transfers this data as a single-ended output (RXD) to the CAN controller. It consists of a comparator that senses the difference $\Delta V = (\text{CANH} - \text{CANL})$ with respect to an internal threshold of 0.7V. If this difference is positive (i.e., $\Delta V > 0.7$), a logic low is present at RXD. If negative (i.e., $\Delta V < 0.7V$), a logic high is present. The receiver always echoes the CAN BUS data.

The CANH and CANL common-mode range is -7V to +12V for the MAX3058, and 0V to V_{CC} for the MAX3059. RXD is logic high when CANH and CANL are either shorted, or terminated and undriven.

Mode Selection

High-Speed Mode

Connect RS to ground to set the MAX3058/MAX3059 to high-speed mode. When operating in high-speed mode, the MAX3058/MAX3059 can achieve transmission rates of up to 1Mbps. In high-speed mode, use shielded twisted-pair cable to avoid EMI problems.

Slope-Control Mode

Connect a resistor from RS to ground to select slope-control mode (Table 3). In slope-control mode, CANH and CANL slew rates are controlled by the resistor connected to the RS pin. Maximum transmission speeds are controlled by R_{RS} , and range from 40kbps to 500kbps. Controlling the rise and fall slopes reduces EMI and allows the use of an unshielded twisted pair or a parallel pair of wires as bus lines. The transfer function for selecting the resistor value is given by:

$$R_{RS} (\text{k}\Omega) \approx 12,500 / (\text{maximum speed in kbps})$$

See the Slew Rate vs. R_{RS} graph in the *Typical Operating Characteristics*.

Table 3. Mode Selection Truth Table

CONDITION FORCED AT PIN RS	MODE	RESULTING CURRENT AT RS (μA)
$V_{RS} < 0.3 \times V_{CC}$	High speed	$ I_{RS} < 500$
$0.4 \times V_{CC} < V_{RS} < 0.6 \times V_{CC}$	Slope control	$10\mu\text{A} < I_{RS} < 200$
$V_{RS} > 0.75 \times V_{CC}$	Standby (MAX3058)	$ I_{RS} < 10$
$V_{RS} > 0.75 \times V_{CC}$	Shutdown (MAX3059)	$ I_{RS} < 10$

Standby Mode

If a logic-high level is applied to RS, the MAX3058 enters a low-current standby mode. In this mode, the transmitter is switched off and the receiver is switched to a low-current/low-speed state. If dominant bits are detected, RXD switches to low level. The microcontroller should react to this condition by switching the transceiver back to normal operation.

When the MAX3058 enters standby mode, RXD goes high for 4 μs (max) regardless of the BUS state. However, after 4 μs , RXD goes low only when the BUS is dominant; otherwise, RXD remains high (when the BUS is recessive). For proper measurement of standby to receiver active time (t_{SBRXDL}), the BUS should be in a dominant state (see Figure 2).

Shutdown Mode

Drive SHDN high to enter shutdown mode on the MAX3058. Connect SHDN to ground or leave it floating for normal operation. On the MAX3059, drive RS high to enter shutdown.

TERM

Drive TERM high (to V_{CC}) or leave it floating to terminate the MAX3059 with 120 Ω resistor connected across the CANH and CANL. Connect TERM to ground to disconnect this resistor.

Thermal Shutdown

If the junction temperature exceeds +160°C, the device is switched off. The hysteresis is approximately 25°C, disabling thermal shutdown once the temperature drops to +135°C. In thermal shutdown, CANH and CANL go recessive and all IC functions are disabled.

5V, 1Mbps, Low Supply Current CAN Transceivers

MAX3058/MAX3059

Applications Information

Reduced EMI and Reflections

In slope-control mode, the CANH and CANL outputs are slew-rate limited, minimizing EMI and reducing reflections caused by improperly terminated cables.

In multidrop CAN applications, it is important to maintain a direct point-to-point wiring scheme. A single pair of wires should connect each element of the CAN bus, and the two ends of the bus should be terminated with 120Ω resistors. A star configuration should never be used.

Any deviation from the point-to-point wiring scheme creates a stub. The high-speed edge of the CAN data on a stub can create reflections back down the bus. These reflections can cause data errors by eroding the noise margin of the system.

Although stubs are unavoidable in a multidrop system, care should be taken to keep these stubs as small as possible, especially in high-speed mode. In slope-control mode, the requirements are not as rigorous, but stub length should still be minimized.

Power Supply and Bypassing

The MAX3058/MAX3059 require no special layout considerations beyond common practices. Bypass V_{CC} to GND with a $0.1\mu\text{F}$ ceramic capacitor mounted close to the IC with short lead lengths and wide trace widths.

Chip Information

TRANSISTOR COUNT: 1024

PROCESS: BiCMOS

Typical Operating Circuit

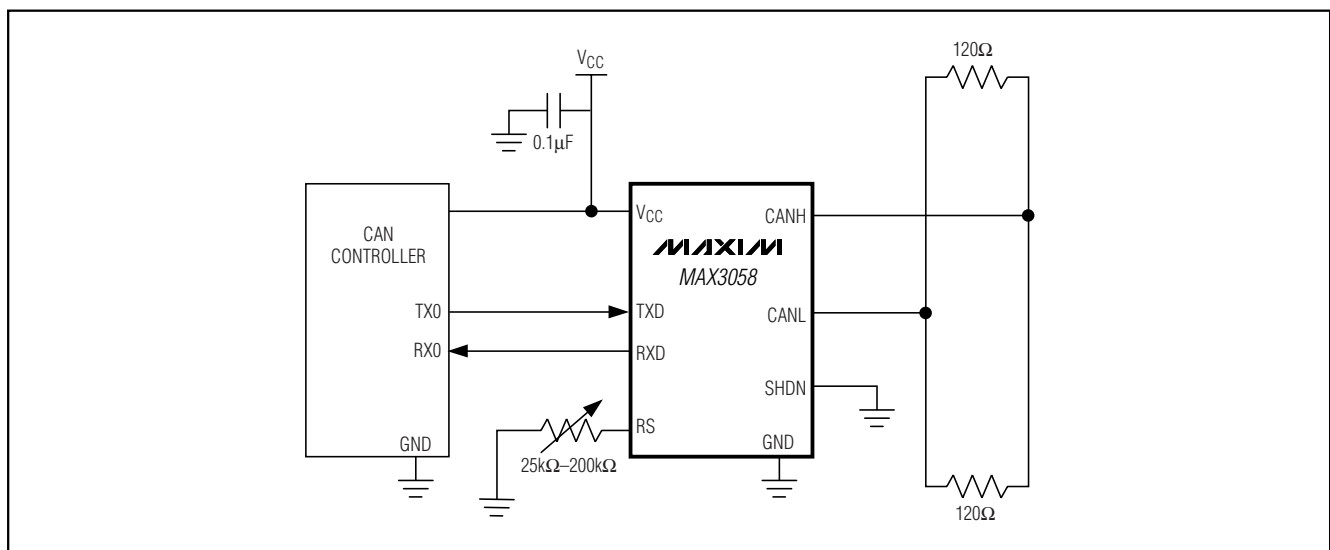

5V, 1Mbps, Low Supply Current CAN Transceivers

Package Information

(The package drawing(s) in this data sheet may not reflect the most current specifications. For the latest package outline information, go to www.maxim-ic.com/packages.)

SOICN .EPS

DIM	INCHES		MILLIMETERS	
	MIN	MAX	MIN	MAX
A	0.053	0.069	1.35	1.75
A1	0.004	0.010	0.10	0.25
B	0.014	0.019	0.35	0.49
C	0.007	0.010	0.19	0.25
e	0.050 BSC		1.27 BSC	
E	0.150	0.157	3.80	4.00
H	0.228	0.244	5.80	6.20
L	0.016	0.050	0.40	1.27

VARIATIONS:

DIM	INCHES		MILLIMETERS		N	MS012
	MIN	MAX	MIN	MAX		
D	0.189	0.197	4.80	5.00	8	AA
D	0.337	0.344	8.55	8.75	14	AB
D	0.386	0.394	9.80	10.00	16	AC

NOTES:

1. D&E DO NOT INCLUDE MOLD FLASH.
2. MOLD FLASH OR PROTRUSIONS NOT TO EXCEED 0.15mm (.006").
3. LEADS TO BE COPLANAR WITHIN 0.10mm (.004").
4. CONTROLLING DIMENSION: MILLIMETERS.
5. MEETS JEDEC MS012.
6. N = NUMBER OF PINS.

PROPRIETARY INFORMATION

TITLE:
PACKAGE OUTLINE, .150" SOIC



APPROVAL	DOCUMENT CONTROL NO. 21-0041	REV. B	1/1
----------	---------------------------------	-----------	-----

Maxim cannot assume responsibility for use of any circuitry other than circuitry entirely embodied in a Maxim product. No circuit patent licenses are implied. Maxim reserves the right to change the circuitry and specifications without notice at any time.

12 _____ **Maxim Integrated Products, 120 San Gabriel Drive, Sunnyvale, CA 94086 408-737-7600**

Looking for pricing, stock, or lifecycle information?

Click below to explore more details on WIN SOURCE:

-  [View MAX3058ASA+T on WIN SOURCE](#)
-  [Maxim Integrated Information](#)

Optimize Your Supply Chain with WIN SOURCE Solutions

-  Global Sourcing Solution
-  Obsolete Management
-  Cost Control Management
-  Shortage Management
-  Alternative Solution
-  Excess Inventory Management