



**MAXIM**

# Ultra-Small, 1.8V, $\mu$ Power, Rail-to-Rail I/O Op Amps

**MAX4291/MAX4292/MAX4294**

## General Description

The MAX4291/MAX4292/MAX4294 family of micropower operational amplifiers operates from a 1.8V to 5.5V single supply or  $\pm 0.9V$  to  $\pm 2.75V$  dual supplies and has Rail-to-Rail<sup>®</sup> input/output capabilities. These amplifiers provide a 500kHz gain-bandwidth product and 120dB open-loop voltage gain while using only 100 $\mu$ A of supply current per amplifier. The combination of low input offset voltage ( $\pm 200\mu V$ ) and high open-loop gain makes them ideal for low-power/low-voltage, high-precision portable applications.

The MAX4291/MAX4292/MAX4294 have an input common-mode range that extends to each supply rail, and their outputs swing to within 46mV of the rails with a 2k $\Omega$  load. Although the minimum operating voltage is specified at 1.8V, these devices typically operate down to 1.5V. The combination of ultra-low-voltage operation, rail-to-rail inputs/output, and low-power consumption makes these devices ideal for any portable/two-cell battery-powered system.

The single MAX4291 is offered in an ultra-small 5-pin SC70 package. The dual MAX4292 is offered in a space-saving 8-bump, 1.5mm X 1.5mm footprint, ultra chip-scale package (UCSP<sup>™</sup>).

## Applications

2-Cell Battery-Operated Systems  
 Portable Electronic Equipment  
 Battery-Powered Instrumentation  
 Digital Scales  
 Strain Gauges  
 Sensor Amplifiers  
 Cellular Phones

## Pin Configurations

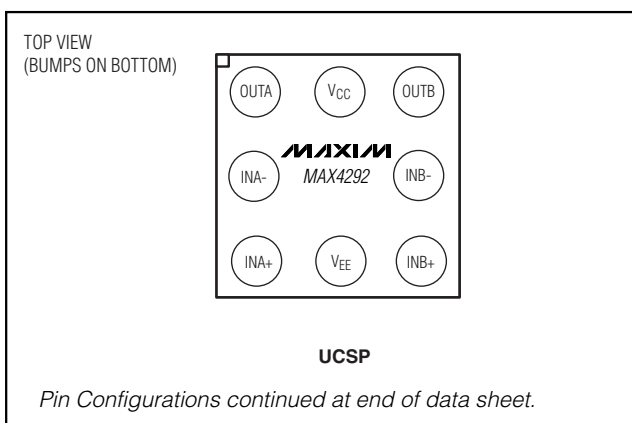

## Features

- ◆ Ultra-Low Voltage Operation—Guaranteed Down to 1.8V
- ◆ 100 $\mu$ A Supply Current per Amplifier
- ◆ 500kHz Gain-Bandwidth Product
- ◆ 120dB Open-Loop Voltage Gain ( $R_L = 100k\Omega$ )
- ◆ 0.017% Total Harmonic Distortion Plus Noise (THD + N) at 1kHz
- ◆ Rail-to-Rail Input Common-Mode Range
- ◆ Rail-to-Rail Output Drives 2k $\Omega$  Load
- ◆ No Phase Reversal for Overdriven Inputs
- ◆ Unity-Gain Stable for Capacitive Loads up to 100pF
- ◆ 200 $\mu$ V Input Offset Voltage (MAX4292/MAX4294)
- ◆ Single in Small 5-Pin SC70
- ◆ Available in Ultra-Small Packages:
  - 5-Pin SC70 (MAX4291)
  - 8-Bump UCSP (MAX4292)

## Ordering Information

| PART          | TEMP RANGE     | PIN-PACKAGE | TOP MARK |
|---------------|----------------|-------------|----------|
| MAX4291EXK-T  | -40°C to +85°C | 5 SC70-5    | AAD      |
| MAX4291EUK-T  | -40°C to +85°C | 5 SOT23-5   | ADML     |
| MAX4292EBL-T* | -40°C to +85°C | 8 UCSP-8    | AAJ      |
| MAX4292EUA    | -40°C to +85°C | 8 $\mu$ MAX | —        |
| MAX4292ESA    | -40°C to +85°C | 8 SO        | —        |
| MAX4294ESD    | -40°C to +85°C | 14 SO       | —        |
| MAX4294EUD    | -40°C to +85°C | 14 TSSOP    | —        |

\*UCSP reliability is integrally linked to the user's assembly methods, circuit board material, and environment. Refer to the UCSP Reliability Notice in the UCSP Reliability section of this data sheet for more information.

## Selector Guide

| PART    | AMPLIFIERS | PIN-PACKAGE             |
|---------|------------|-------------------------|
| MAX4291 | 1          | 5-pin SC70/SOT23        |
| MAX4292 | 2          | 8-pin $\mu$ MAX/SO/UCSP |
| MAX4294 | 4          | 14-pin SO/TSSOP         |

Rail-to-Rail is a registered trademark of Nippon Motorola, Ltd.  
 UCSP is a trademark of Maxim Integrated Products, Inc.

**MAXIM**

Maxim Integrated Products 1

**For pricing, delivery, and ordering information, please contact Maxim/Dallas Direct! at 1-888-629-4642, or visit Maxim's website at [www.maxim-ic.com](http://www.maxim-ic.com).**

# Ultra-Small, 1.8V, $\mu$ Power, Rail-to-Rail I/O Op Amps

## ABSOLUTE MAXIMUM RATINGS

|  |  |
|--|--|
| Supply Voltage ( $V_{CC}$ to $V_{EE}$ ).....6V                 | 8-Pin $\mu$ MAX (derate 4.10mW/°C above +70°C).....330mW |
| All Other Pins .....( $V_{CC} + 0.3V$ ) to ( $V_{EE} - 0.3V$ ) | 8-Pin SO (derate 5.88mW/°C above +70°C) .....471mW       |
| Current into $IN_+$ , $IN_-$ ..... $\pm 25mA$                  | 14-Pin SO (derate 8.33mW/°C above +70°C) .....667mW      |
| Output Short-Circuit Duration.....Continuous                   | 14-Pin TSSOP (derate 6.3mW/°C above +70°C).....500mW     |
| Continuous Power Dissipation ( $T_A = +70^\circ C$ )           | Operating Temperature Range.....-40°C to +85°C           |
| 5-Pin SC70 (derate 2.5mW/°C above +70°C) .....200mW            | Junction Temperature .....+150°C                         |
| 5-Pin SOT23 (derate 7.1mW/°C above +70°C).....571mW            | Storage Temperature Range .....-65°C to +150°C           |
| 8-Bump UCSP (derate 4.7mW/°C above +70°C).....379mW            | Lead Temperature (soldering, 10s) .....+300°C            |

Stresses beyond those listed under "Absolute Maximum Ratings" may cause permanent damage to the device. These are stress ratings only, and functional operation of the device at these or any other conditions beyond those indicated in the operational sections of the specifications is not implied. Exposure to absolute maximum rating conditions for extended periods may affect device reliability.

## ELECTRICAL CHARACTERISTICS

( $V_{CC} = 1.8V$  to  $5.5V$ ,  $V_{EE} = V_{CM} = 0$ ,  $V_{OUT} = V_{CC}/2$ ,  $R_L = 100k\Omega$  connected to  $V_{CC}/2$ ,  $T_A = +25^\circ C$ , unless otherwise noted.)  
(Note 1)

| PARAMETER                                   | SYMBOL   | CONDITIONS   | MIN             | TYP       | MAX        | UNITS      |
|---|----------|--|-----------------|-----------|------------|------------|
| Supply Voltage Range                        | $V_{CC}$ | Inferred from PSRR test                                      | 1.8             |           | 5.5        | V          |
| Quiescent Supply Current<br>(Per Amplifier) | $I_Q$    | $V_{CC} = 1.8V$  |                 | 100       | 210        | $\mu A$    |
|   |          | $V_{CC} = 5.0V$  |                 | 100       | 255        |            |
| Input Offset Voltage                        | $V_{OS}$ | MAX4291  |                 | $\pm 400$ | $\pm 2500$ | $\mu V$    |
|   |          | MAX4292/MAX4294  |                 | $\pm 200$ | $\pm 1200$ |            |
| Input Bias Current                          | $I_B$    | $V_{CC} = 5.0V, 0 \leq V_{CM} \leq 5.0V$                     |                 | $\pm 15$  | $\pm 60$   | nA         |
| Input Offset Current                        | $I_{OS}$ | $V_{CC} = 5.0V, 0 \leq V_{CM} \leq 5.0V$                     |                 | $\pm 1$   | $\pm 7$    | nA         |
| Differential Input Resistance               | $R_{IN}$ | $ V_{IN+} - V_{IN-}  < 10mV$                                 |                 | 0.75      |            | M $\Omega$ |
| Input Common-Mode Voltage Range             | $V_{CM}$ | Inferred from CMRR test                                      | 0               |           | $V_{CC}$   | V          |
| Common-Mode Rejection Ratio                 | CMRR     | Tested for<br>$0 \leq V_{CM} \leq 1.8V$ ;<br>$V_{CC} = 1.8V$ | MAX4291         | 50        | 80         | dB         |
|   |          |  | MAX4292/MAX4294 | 57        | 80         |            |
|   |          | Tested for<br>$0 \leq V_{CM} \leq 5.0V$ ;<br>$V_{CC} = 5.0V$ | MAX4291         | 60        | 90         | dB         |
|   |          |  | MAX4292/MAX4294 | 66        | 90         |            |
| Power-Supply Rejection Ratio                | PSRR     |  | 77              | 100       |            | dB         |

# Ultra-Small, 1.8V, $\mu$ Power, Rail-to-Rail I/O Op Amps

MAX4291/MAX4292/MAX4294

## ELECTRICAL CHARACTERISTICS (continued)

( $V_{CC} = 1.8V$  to  $5.5V$ ,  $V_{EE} = V_{CM} = 0$ ,  $V_{OUT} = V_{CC}/2$ ,  $R_L = 100k\Omega$  connected to  $V_{CC}/2$ ,  $T_A = +25^\circ C$ , unless otherwise noted.)  
(Note 1)

| PARAMETER                    | SYMBOL        | CONDITIONS                                      |  | MIN | TYP  | MAX | UNITS           |
|------------------------------|---------------|---|--|-----|------|-----|-----------------|
| Large-Signal Voltage Gain    | $A_V$         | $V_{CC} = 1.8V$                                 | $R_L = 100k\Omega$ ,<br>$0.02V \leq V_{OUT} \leq V_{CC} - 0.02V$ | 80  | 120  |     | dB              |
|                              |               |   | $R_L = 2k\Omega$ ,<br>$0.1V \leq V_{OUT} \leq V_{CC} - 0.1V$     | 80  | 110  |     |                 |
|                              |               | $V_{CC} = 5.0V$                                 | $R_L = 100k\Omega$ ,<br>$0.02V \leq V_{OUT} \leq V_{CC} - 0.02V$ | 80  | 130  |     |                 |
|                              |               |   | $R_L = 2k\Omega$ ,<br>$0.1V \leq V_{OUT} \leq V_{CC} - 0.1V$     | 80  | 120  |     |                 |
| Output-Voltage Swing High    | $V_{OH}$      | Specified as<br>$ V_{CC} - V_{OH} $             | $R_L = 100k\Omega$ to $V_{CC}/2$                                 |     | 2    | 20  | mV              |
|                              |               |   | $R_L = 2k\Omega$ to $V_{CC}/2$                                   |     | 15   | 40  |                 |
| Output-Voltage Swing Low     | $V_{OL}$      | Specified as<br>$ V_{EE} - V_{OL} $             | $R_L = 100k\Omega$ to $V_{CC}/2$                                 |     | 25   | 80  | mV              |
|                              |               |   | $R_L = 2k\Omega$ to $V_{CC}/2$                                   |     | 46   | 120 |                 |
| Output Short-Circuit Current | $I_{OUT(SC)}$ | Sourcing or sinking                             |  |     | 20   |     | mA              |
| Channel-to-Channel Isolation | $CH_{ISO}$    | Specified at $f = 10kHz$ (MAX4292/MAX4294 only) |  |     | 83   |     | dB              |
| Gain-Bandwidth Product       | $GBWP$        |   |  |     | 500  |     | kHz             |
| Phase Margin                 | $\phi_M$      |   |  |     | 65   |     | degrees         |
| Gain Margin                  | $GM$          |   |  |     | 12   |     | dB              |
| Slew Rate                    | $SR$          |   |  |     | 0.2  |     | V/ $\mu s$      |
| Input Voltage-Noise Density  | $e_n$         | $f = 10kHz$                                     |  |     | 70   |     | nV/ $\sqrt{Hz}$ |
| Input Current-Noise Density  | $i_n$         | $f = 10kHz$                                     |  |     | 0.05 |     | pA/ $\sqrt{Hz}$ |
| Capacitive-Load Stability    |               | $AV_{CL} = 1V/V$ , no sustained oscillations    |  |     | 100  |     | pF              |

## ELECTRICAL CHARACTERISTICS

( $V_{CC} = 1.8V$  to  $5.5V$ ,  $V_{EE} = V_{CM} = 0$ ,  $V_{OUT} = V_{CC}/2$ ,  $R_L = 100k\Omega$  connected to  $V_{CC}/2$ ,  $T_A = T_{MIN}$  to  $T_{MAX}$ , unless otherwise noted.)  
(Note 1)

| PARAMETER                                   | SYMBOL   | CONDITIONS              | MIN | TYP | MAX        | UNITS   |
|---|----------|-------------------------|-----|-----|------------|---------|
| Supply-Voltage Range                        | $V_{CC}$ | Inferred from PSRR test | 1.8 |     | 5.5        | V       |
| Quiescent Supply Current<br>(Per Amplifier) | $I_Q$    | $V_{CC} = 1.8V$         |     |     | 240        | $\mu A$ |
|   |          | $V_{CC} = 5.0V$         |     |     | 270        |         |
| Input Offset Voltage                        | $V_{OS}$ | MAX4291                 |     |     | $\pm 3000$ | $\mu V$ |
|   |          | MAX4292/MAX4294         |     |     | $\pm 2000$ |         |

# Ultra-Small, 1.8V, $\mu$ Power, Rail-to-Rail I/O Op Amps

## ELECTRICAL CHARACTERISTICS (continued)

( $V_{CC} = 1.8V$  to  $5.5V$ ,  $V_{EE} = V_{CM} = 0$ ,  $V_{OUT} = V_{CC}/2$ ,  $R_L = 100k\Omega$  connected to  $V_{CC}/2$ ,  $T_A = T_{MIN}$  to  $T_{MAX}$ , unless otherwise noted.)  
(Note 1)

| PARAMETER                       | SYMBOL            | CONDITIONS   |  | MIN | TYP | MAX             | UNITS            |
|---------------------------------|-------------------|--|--|-----|-----|-----------------|------------------|
| Input Offset Voltage Drift      | TCV <sub>OS</sub> |  |  | 1.2 |     |                 | $\mu V/^\circ C$ |
| Input Bias Current              | I <sub>B</sub>    | $V_{CC} = 5.0V$ , $0 \leq V_{CM} \leq 5.0V$                  |  |     |     | $\pm 90$        | nA               |
| Input Offset Current            | I <sub>OS</sub>   | $V_{CC} = 5.0V$ , $0 \leq V_{CM} \leq 5.0V$                  |  |     |     | $\pm 10$        | nA               |
| Input Common-Mode Voltage Range | V <sub>CM</sub>   | Inferred from CMRR test                                      |  | 0   |     | V <sub>CC</sub> | V                |
| Common-Mode Rejection Ratio     | CMRR              | Tested for<br>$0 \leq V_{CM} \leq 1.8V$ ,<br>$V_{CC} = 1.8V$ | MAX4291  | 50  |     |                 | dB               |
|                                 |                   |  | MAX4292/MAX4294  | 53  |     |                 |                  |
|                                 |                   | Tested for<br>$0 \leq V_{CM} \leq 5.0V$ ,<br>$V_{CC} = 5.0V$ | MAX4291  | 60  |     |                 | dB               |
|                                 |                   |  | MAX4292/MAX4294  | 62  |     |                 |                  |
| Power-Supply Rejection Ratio    | PSRR              |  |  | 75  |     |                 | dB               |
| Large-Signal Voltage Gain       | A <sub>v</sub>    | V <sub>CC</sub> = 1.8V                                       | R <sub>L</sub> = 100k $\Omega$ ,<br>$0.02V \leq V_{OUT} \leq V_{CC} - 0.02V$ | 80  |     |                 | dB               |
|                                 |                   |  | R <sub>L</sub> = 2k $\Omega$ ,<br>$0.1V \leq V_{OUT} \leq V_{CC} - 0.1V$     | 80  |     |                 |                  |
|                                 |                   | V <sub>CC</sub> = 5.0V                                       | R <sub>L</sub> = 100k $\Omega$ ,<br>$0.02V \leq V_{OUT} \leq V_{CC} - 0.02V$ | 80  |     |                 |                  |
|                                 |                   |  | R <sub>L</sub> = 2k $\Omega$ ,<br>$0.1V \leq V_{OUT} \leq V_{CC} - 0.1V$     | 80  |     |                 |                  |
| Output-Voltage Swing High       | V <sub>OH</sub>   | Specified as<br> V <sub>CC</sub> - V <sub>OH</sub>           | R <sub>L</sub> = 100k $\Omega$ to $V_{CC}/2$                                 |     |     | 20              | mV               |
|                                 |                   |  | R <sub>L</sub> = 2k $\Omega$ to $V_{CC}/2$                                   |     |     | 40              |                  |
| Output-Voltage Swing Low        | V <sub>OL</sub>   | Specified as<br> V <sub>EE</sub> - V <sub>OL</sub>           | R <sub>L</sub> = 100k $\Omega$ to $V_{CC}/2$                                 |     |     | 80              | mV               |
|                                 |                   |  | R <sub>L</sub> = 2k $\Omega$ to $V_{CC}/2$                                   |     |     | 120             |                  |

**Note 1:** All devices are 100% tested at  $T_A = +25^\circ C$ . All temperature limits are guaranteed by design.

# Ultra-Small, 1.8V, $\mu$ Power, Rail-to-Rail I/O Op Amps

## Typical Operating Characteristics

( $V_{CC} = 2.4V$ ,  $V_{EE} = V_{CM} = 0$ ,  $V_{OUT} = V_{CC}/2$ , no load,  $T_A = +25^\circ C$ , unless otherwise noted.)

MAX4291/MAX4292/MAX4294

**SUPPLY CURRENT PER AMPLIFIER vs. TEMPERATURE**

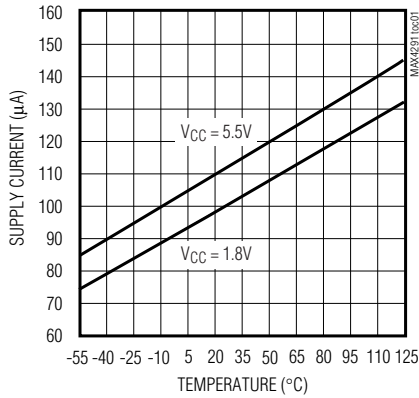

**MINIMUM OPERATING VOLTAGE vs. TEMPERATURE (PSRR  $\geq$  80dB)**

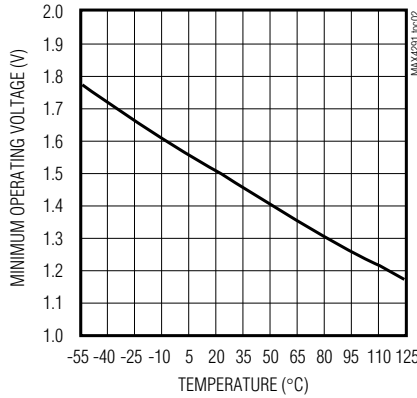

**INPUT OFFSET VOLTAGE vs. TEMPERATURE**

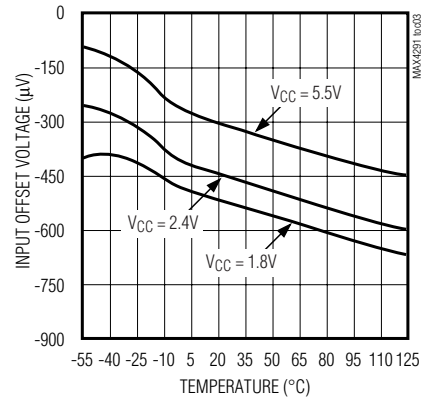

**INPUT BIAS CURRENT vs. TEMPERATURE**

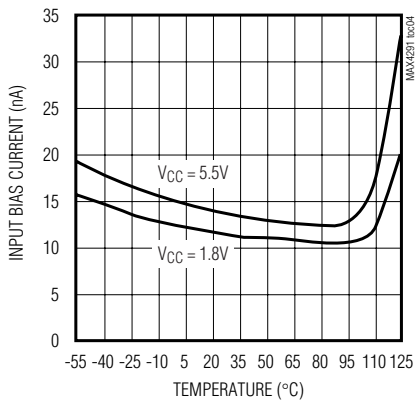

**INPUT BIAS CURRENT vs. COMMON-MODE VOLTAGE ( $V_{CC} = 1.8V$ )**

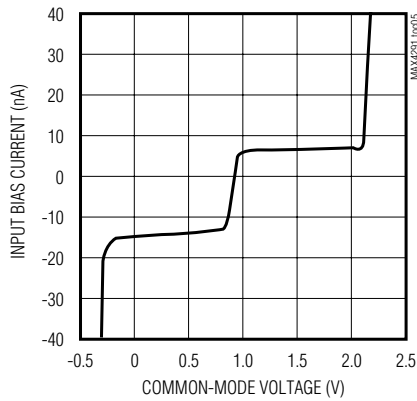

**INPUT BIAS CURRENT vs. COMMON-MODE VOLTAGE ( $V_{CC} = 5.5V$ )**

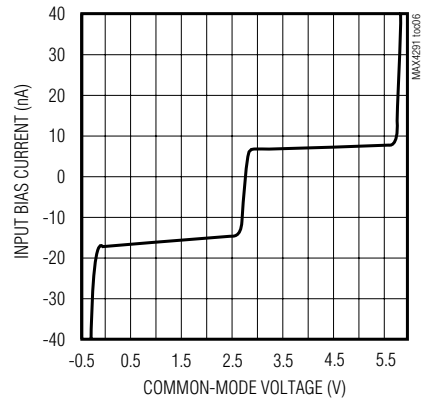

**OUTPUT VOLTAGE SWING vs. TEMPERATURE ( $R_L = 100k\Omega$  TO  $V_{CC}/2$ )**

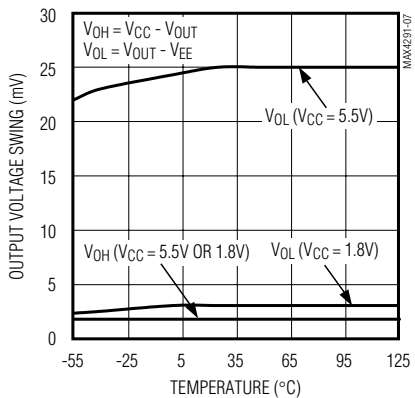

**OUTPUT VOLTAGE SWING vs. TEMPERATURE ( $R_L = 2k\Omega$  TO  $V_{CC}/2$ )**

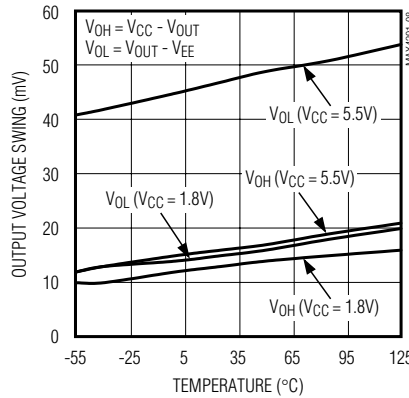

**COMMON-MODE REJECTION RATIO vs. TEMPERATURE**

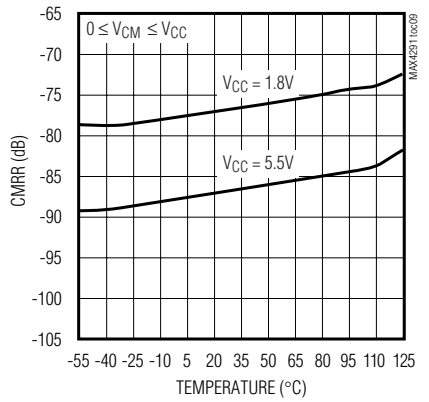

# Ultra-Small, 1.8V, $\mu$ Power, Rail-to-Rail I/O Op Amps

## Typical Operating Characteristics (continued)

( $V_{CC} = 2.4V$ ,  $V_{EE} = V_{CM} = 0$ ,  $V_{OUT} = V_{CC}/2$ , no load,  $T_A = +25^\circ C$ , unless otherwise noted.)

**OPEN-LOOP GAIN vs. OUTPUT SWING LOW**  
( $V_{CC} = 1.8V$ ,  $R_L$  CONNECTED TO  $V_{CC}$ )

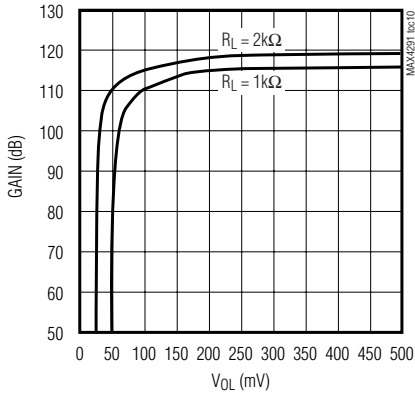

**OPEN-LOOP GAIN vs. OUTPUT SWING HIGH**  
( $V_{CC} = 1.8V$ ,  $R_L$  CONNECTED TO  $V_{EE}$ )

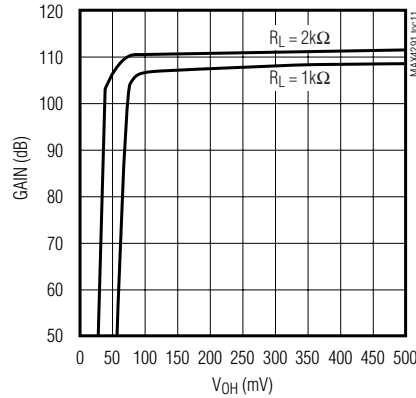

**OPEN-LOOP GAIN vs. OUTPUT SWING LOW**  
( $V_{CC} = 5.5V$ ,  $R_L$  CONNECTED TO  $V_{CC}$ )

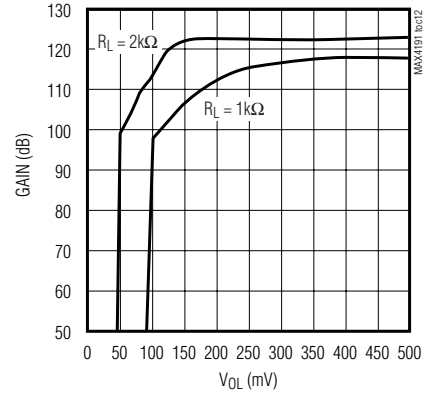

**OPEN-LOOP GAIN vs. OUTPUT SWING HIGH**  
( $V_{CC} = 5.5V$ ,  $R_L$  CONNECTED TO  $V_{EE}$ )

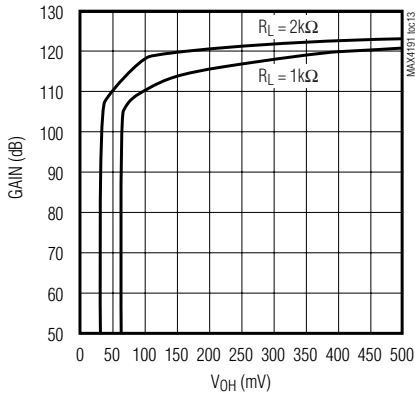

**OPEN-LOOP GAIN vs. TEMPERATURE**

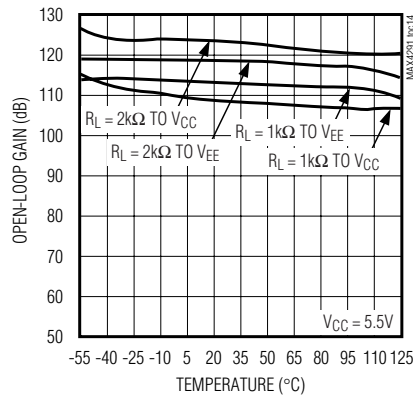

**MAX4292/MAX4294**  
**CROSSTALK vs. FREQUENCY**

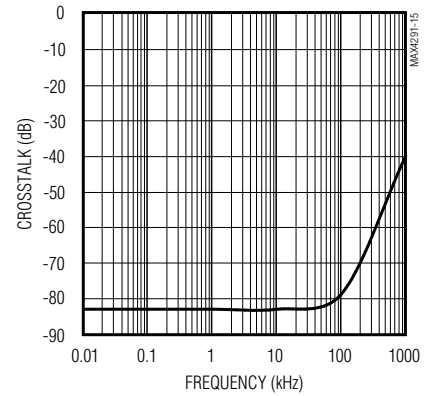

**GAIN AND PHASE vs. FREQUENCY**  
( $C_L = 0$ )

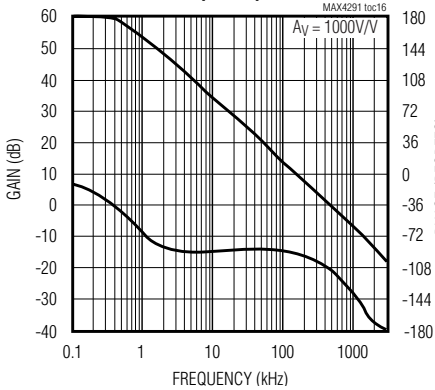

**GAIN AND PHASE vs. FREQUENCY**  
( $C_L = 100pF$ )

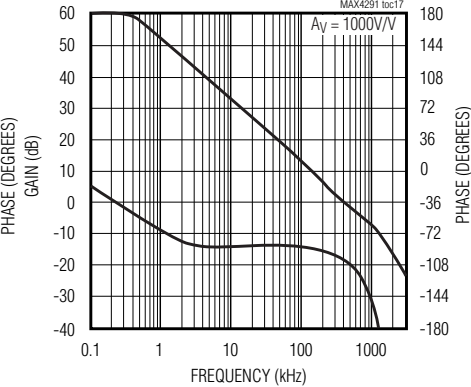

**TOTAL HARMONIC DISTORTION PLUS NOISE vs. FREQUENCY**

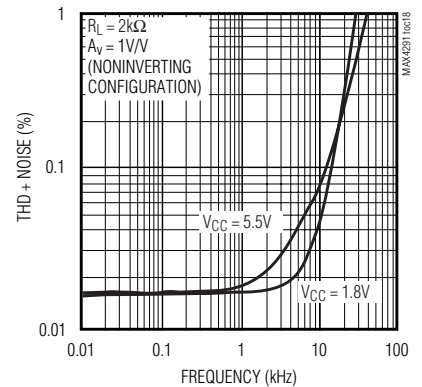

# Ultra-Small, 1.8V, $\mu$ Power, Rail-to-Rail I/O Op Amps

## Typical Operating Characteristics (continued)

( $V_{CC} = 2.4V$ ,  $V_{EE} = V_{CM} = 0$ ,  $V_{OUT} = V_{CC}/2$ , no load,  $T_A = +25^\circ C$ , unless otherwise noted.)

MAX4291/MAX4292/MAX4294

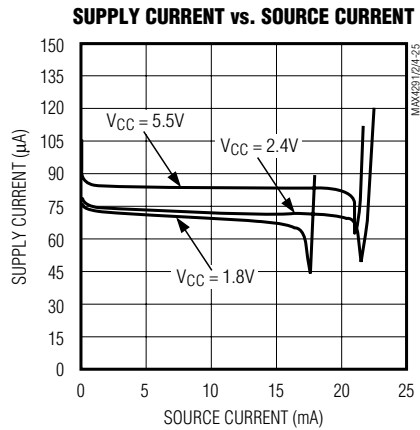
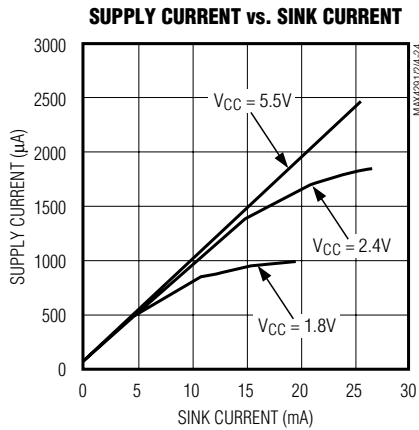
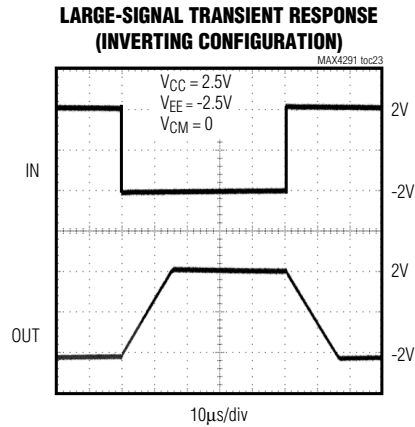
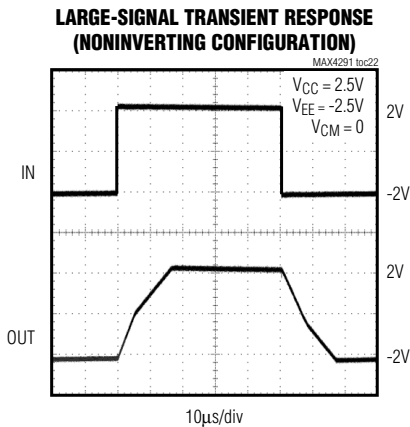
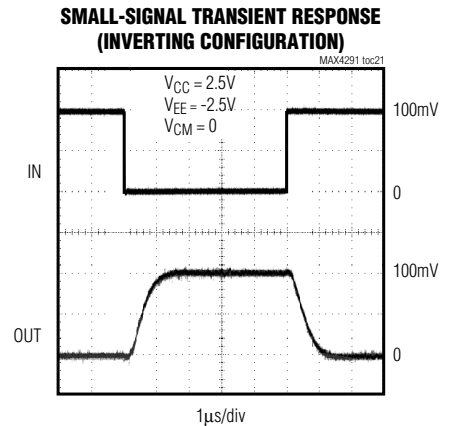
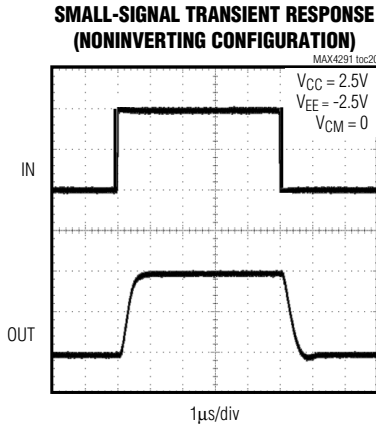
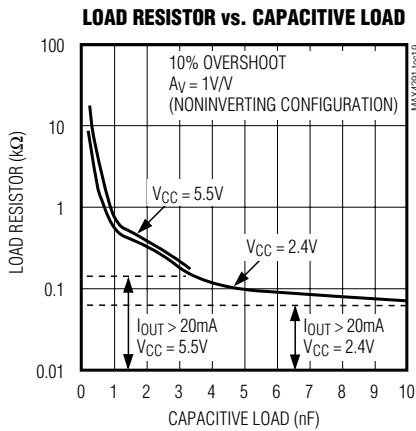

# Ultra-Small, 1.8V, $\mu$ Power, Rail-to-Rail I/O Op Amps

## Pin Description

| PIN     |              |        |         | NAME       | FUNCTION  |
|---------|--------------|--------|---------|------------|---|
| MAX4291 | MAX4292      |        | MAX4294 |            |   |
|         | $\mu$ MAX/SO | UCSP   |         |            |   |
| 1       | —            | —      | —       | IN+        | Noninverting Input  |
| 2       | 4            | C2     | 11      | VEE        | Negative Supply. Connect to ground for single-supply operation. |
| 3       | —            | —      | —       | IN-        | Inverting Input   |
| 4       | —            | —      | —       | OUT        | Amplifier Output  |
| 5       | 8            | A2     | 4       | VCC        | Positive Supply   |
| —       | 1, 7         | A1, A3 | 1, 7    | OUTA, OUTB | Outputs for Amplifiers A and B                                  |
| —       | 2, 6         | B1, B3 | 2, 6    | INA-, INB- | Inverting Inputs to Amplifiers A and B                          |
| —       | 3, 5         | C1, C3 | 3, 5    | INA+, INB+ | Noninverting Inputs to Amplifiers A and B                       |
| —       | —            | —      | 8, 14   | OUTC, OUTD | Outputs for Amplifiers C and D                                  |
| —       | —            | —      | 9, 13   | INC-, IND- | Inverting Inputs to Amplifiers C and D                          |
| —       | —            | —      | 10, 12  | INC+, IND+ | Noninverting Inputs to Amplifiers C and D                       |

## Detailed Description

### Rail-to-Rail Input Stage

The MAX4291/MAX4292/MAX4294 have rail-to-rail inputs and output stages that are specifically designed for low-voltage, single-supply operation in the smallest package possible. The input stage consists of separate NPN and PNP differential stages, which operate together to provide a common-mode range extending to both supply rails. The crossover region of these two pairs occurs halfway between VCC and VEE. The input offset voltage is typically  $\pm 200\mu\text{V}$  (MAX4292/MAX4294). Low operating supply voltage, low supply current, rail-to-rail common-mode input range, and rail-to-rail outputs make this family of operational amplifiers (op amps) an excellent choice for precision or general-purpose, low-voltage, battery-powered systems.

Since the input stage consists of NPN and PNP pairs, the input bias current changes polarity as the common-mode voltage passes through the crossover region. Match the effective impedance seen by each input to reduce the offset error caused by input bias currents flowing through external source impedances (Figures 1a and 1b).

The combination of high-source impedance plus input capacitance (amplifier input capacitance plus stray

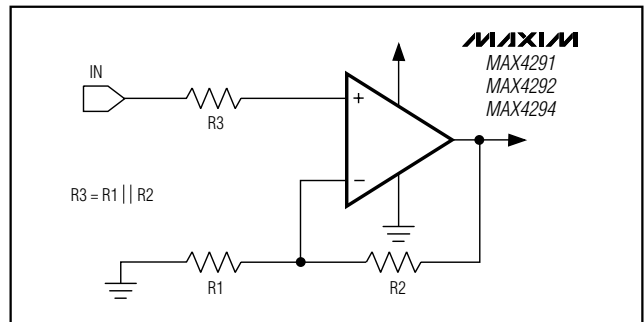

Figure 1a. Minimizing Offset Error Due to Input Bias Current (Noninverting)

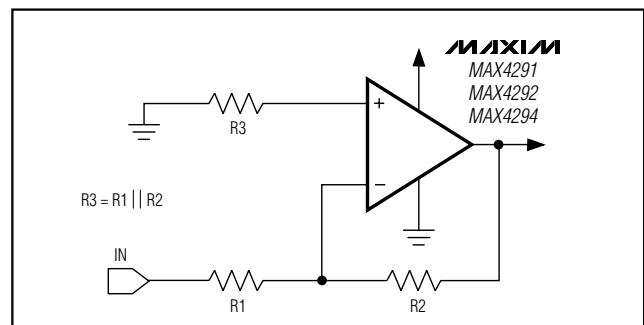

Figure 1b. Minimizing Offset Error Due to Input Bias Current (Inverting)

# Ultra-Small, 1.8V, $\mu$ Power, Rail-to-Rail I/O Op Amps

**Table 1. MAX4291 Characteristics with Typical Battery Systems**

| BATTERY TYPE                   | RECHARGE-ABLE | V <sub>FRESH</sub> (V) | V <sub>END-OF-LIFE</sub> (V) | CAPACITY, AA SIZE (mA-h) | MAX4291 OPERATING TIME IN NORMAL MODE (h) |
|--------------------------------|---------------|------------------------|------------------------------|--------------------------|---|
| Alkaline (2 cells)             | No            | 3.0                    | 1.8                          | 2000                     | 20,000                                    |
| Nickel-Cadmium (2 cells)       | Yes           | 2.4                    | 1.8                          | 750                      | 7500                                      |
| Lithium-Ion (1 cell)           | Yes           | 3.5                    | 2.7                          | 1000                     | 10,000                                    |
| Nickel-Metal-Hydride (2 cells) | Yes           | 2.4                    | 1.8                          | 1000                     | 10,000                                    |

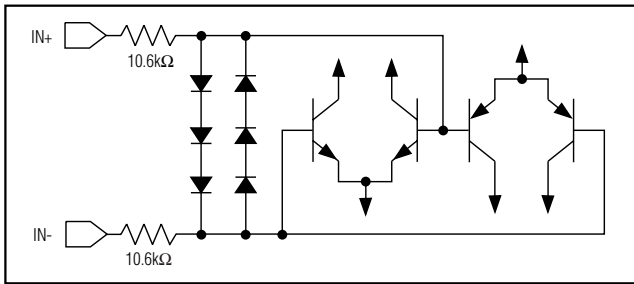

Figure 2. Input Protection Circuit

capacitance) creates a parasitic pole that produces an underdamped signal response. Reducing input capacitance or placing a small capacitor across the feedback resistor improves response in this case.

The MAX4291/MAX4292/MAX4294 family's inputs are protected from large differential input voltages by internal 10.6k $\Omega$  series resistors and back-to-back triple-diode stacks across the inputs (Figure 2). For differential input voltages (much less than 1.8V), input resistance is typically 0.75M $\Omega$ . For differential input voltages greater than 1.8V, input resistance is around 21.2k $\Omega$ , and the input bias current can be approximated by the following equation:

$$I_{BIAS} = \frac{(V_{DIFF} - 1.8V)}{21.2k\Omega}$$

In the region where the differential input voltage approaches 1.8V, the input resistance decreases exponentially from 0.75M $\Omega$  to 21.2k $\Omega$  as the diode block begins to conduct. Conversely, the bias current increases with the same curve.

In unity-gain configuration, high slew-rate input signals may capacitively couple to the output through the triple-diode stacks.

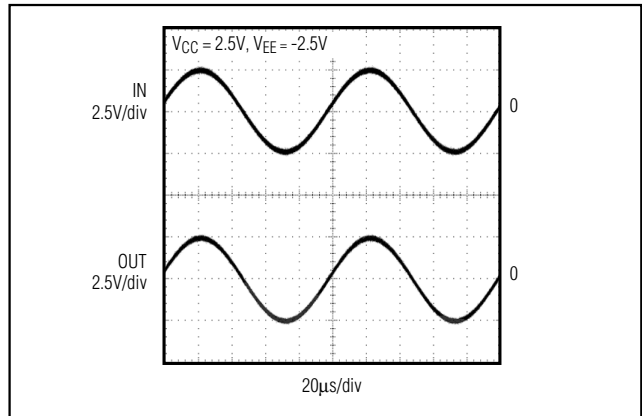

Figure 3. Rail-to-Rail Input/Output Voltage Range

### Rail-to-Rail Output Stage

The MAX4291/MAX4292/MAX4294 output stage can drive up to a 2k $\Omega$  load and still swing to within 46mV of the rails. Figure 3 shows the output-voltage swing of a MAX4291 configured as a unity-gain buffer, powered from a  $\pm 2.5V$  supply. The output for this setup typically swings from (VEE + 25mV) to (VCC - 2mV) with a 100k $\Omega$  load.

### Applications Information

#### Power-Supply Considerations

The MAX4291/MAX4292/MAX4294 operate from a single 1.8V to 5.5V supply (or dual  $\pm 0.9V$  to  $\pm 2.75V$  supplies) and consume only 100 $\mu A$  of supply current per amplifier. A high power-supply rejection ratio of 100dB allows the amplifiers to be powered directly off a decaying battery voltage, simplifying design and extending battery life.

The MAX4291/MAX4292/MAX4294 are ideally suited for use with most battery-powered systems. Table 1 lists a

# Ultra-Small, 1.8V, $\mu$ Power, Rail-to-Rail I/O Op Amps

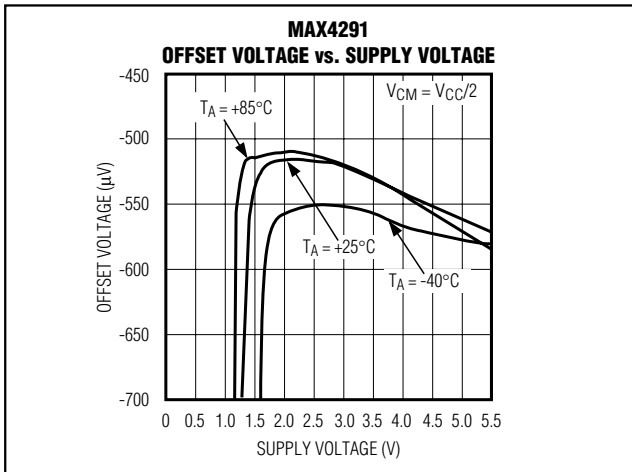

Figure 4. Offset Voltage vs. Supply Voltage

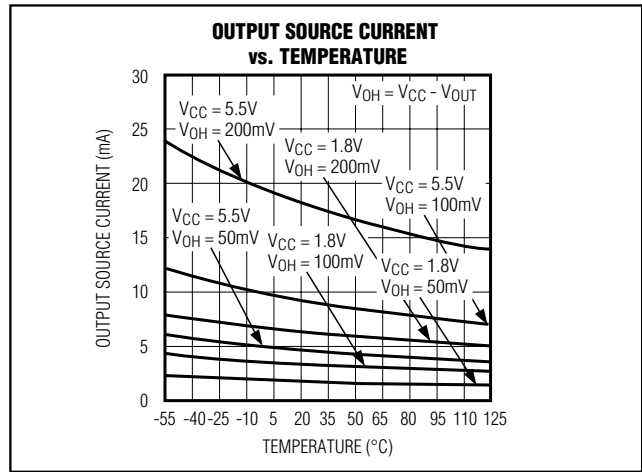

Figure 6a. Output Source Current vs. Temperature

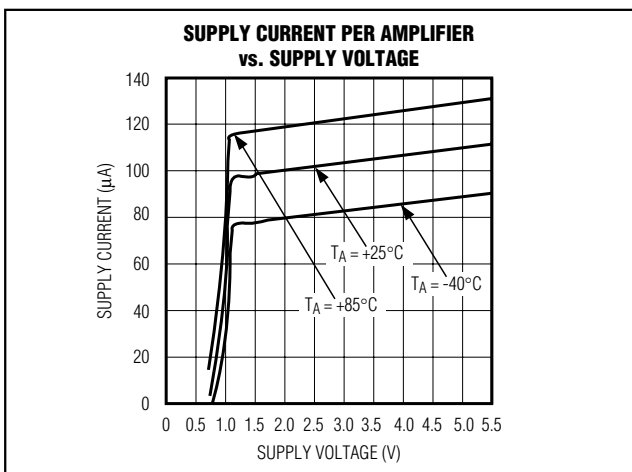

Figure 5. Supply Current per Amplifier vs. Supply Voltage

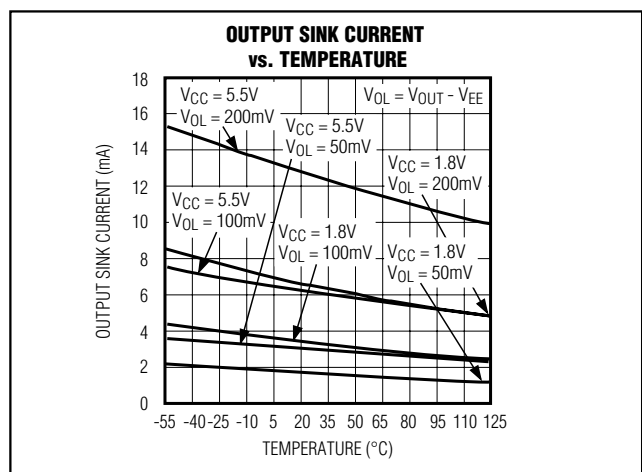

Figure 6b. Output Sink Current vs. Temperature

variety of typical battery types showing voltage when fresh, voltage at end-of-life, capacity, and approximate operating time from a MAX4291 (assuming nominal conditions).

Although the amplifiers are fully guaranteed over temperature for operation down to a 1.8V single supply, even lower voltage operation is possible in practice. Figures 4 and 5 show the offset voltage and supply current as a function of supply voltage and temperature.

### Load-Driving Capability

The MAX4291/MAX4292/MAX4294 are fully guaranteed over temperature and supply voltage range to drive a maximum resistive load of  $2k\Omega$  to  $V_{CC}/2$ , although heavier loads can be driven in many applications. The rail-to-rail output stage of the amplifier can be modeled

as a current source when driving the load toward  $V_{CC}$ , and as a current sink when driving the load toward  $V_{EE}$ . The limit of this current source/sink varies with supply voltage, ambient temperature, and lot-to-lot variations of the units.

Figures 6a and 6b show the typical current source and sink capabilities of the MAX4291/MAX4292/MAX4294 family as a function of supply voltage and ambient temperature. The contours on the graph depict the output current value, based on driving the output voltage to within 50mV, 100mV, and 200mV of either power-supply rail.

For example, a MAX4291 running from a single 1.8V supply, operating at  $T_A = +25^\circ\text{C}$  can source 3.5mA to

# Ultra-Small, 1.8V, $\mu$ Power, Rail-to-Rail I/O Op Amps

MAX4291/MAX4292/MAX4294

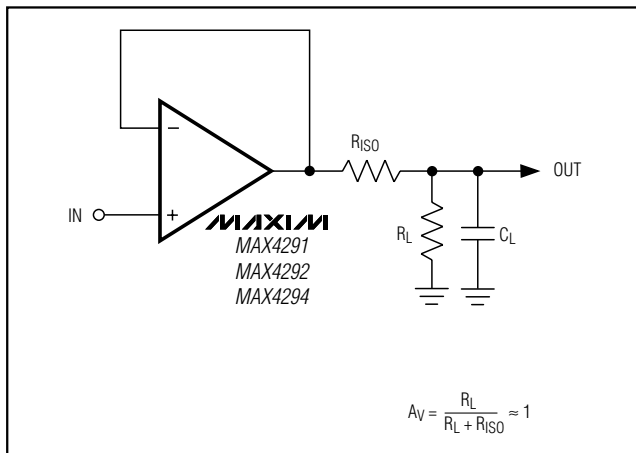

Figure 7a. Using a Resistor to Isolate a Capacitive Load from the Op Amp

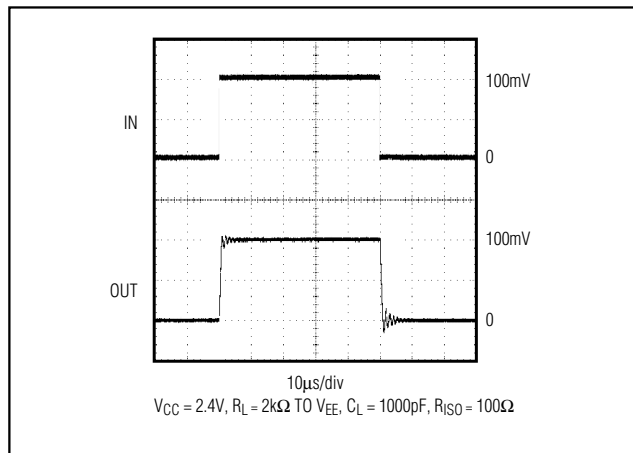

Figure 7c. Pulse Response with Isolating Resistor (100 $\Omega$ )

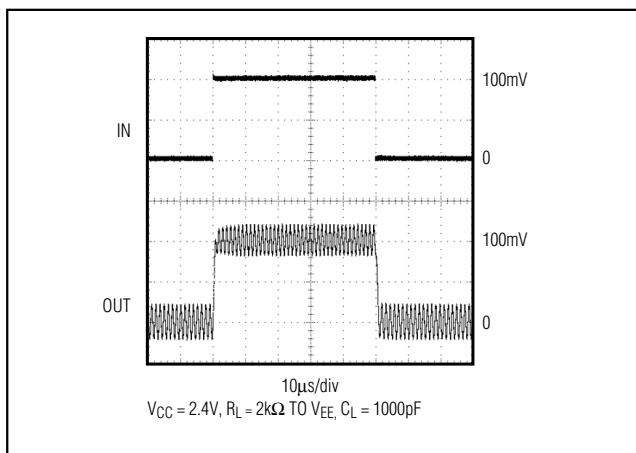

Figure 7b. Pulse Response Without Isolating Resistor

within 100mV of  $V_{CC}$  and is capable of driving a 485 $\Omega$  load resistor to  $V_{EE}$ :

$$R_L = \frac{(1.8V - 0.1V)}{3.5mA} = 485\Omega \text{ to } V_{EE}$$

The same application can drive a 220k $\Omega$  load resistor when terminated in  $V_{CC}/2$  (0.9V in this case).

### Driving Capacitive Loads

The MAX4291/MAX4292/MAX4294 are unity-gain stable for loads up to 100pF (see the Load Resistor vs. Capacitive Load graph in the *Typical Operating Characteristics*). Applications that require greater capacitive-drive capability should use an isolation

resistor between the output and the capacitive load (Figure 7). Note that this alternative results in a loss of gain accuracy because  $R_{ISO}$  forms a voltage divider with the load resistor.

### Power-Supply Bypassing and Layout

The MAX4291/MAX4292/MAX4294 family operates from either a single 1.8V to 5.5V supply or dual  $\pm 0.9V$  to  $\pm 2.75V$  supplies. For single-supply operation, bypass the power supply with a 100nF capacitor to  $V_{EE}$  (in this case GND). For dual-supply operation, both the  $V_{CC}$  and the  $V_{EE}$  supplies should be bypassed to ground with separate 100nF capacitors.

Good PC board layout techniques optimize performance by decreasing the amount of stray capacitance at the op amp's inputs and output. To decrease stray capacitance, minimize trace lengths and widths by placing external components as close as possible to the op amp. Surface-mount components are an excellent choice.

### Using the MAX4291/MAX4292/MAX4294 as Comparators

Although optimized for use as operational amplifiers, the MAX4291/MAX4292/MAX4294 can also be used as rail-to-rail I/O comparators. Typical propagation delay depends on the input overdrive voltage, as shown in Figure 8. External hysteresis can be used to minimize the risk of output oscillation. The positive feedback circuit, shown in Figure 9, causes the input threshold to change when the output voltage changes state. The two thresholds create a hysteresis band that can be calculated by the following equations:

# Ultra-Small, 1.8V, $\mu$ Power, Rail-to-Rail I/O Op Amps

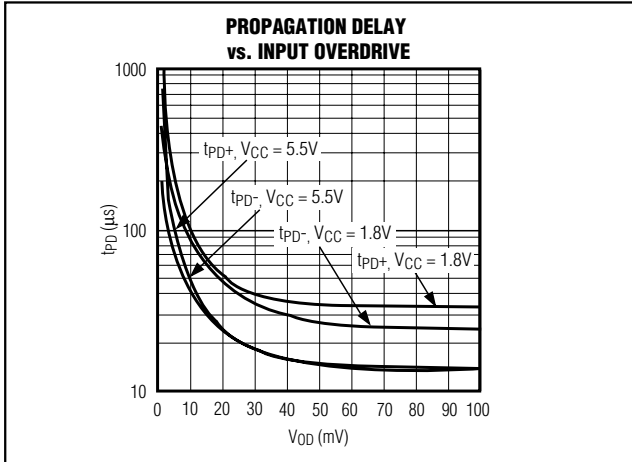

Figure 8. Propagation Delay vs. Input Overdrive

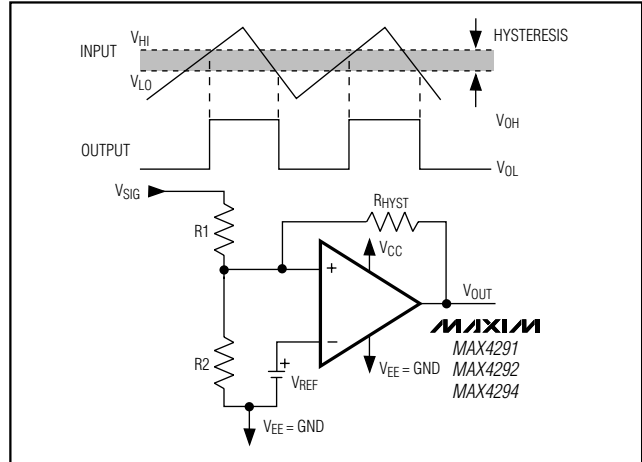

Figure 9. Hysteresis Comparator Circuit

$$V_{HYST} = V_{HI} - V_{LO}$$

$$V_{HI} = \left[ 1 + \frac{R1}{R2} + \frac{R1}{R_{HYST}} \right] V_{REF}$$

$$V_{LO} = V_{HI} - \left( \frac{R1}{R_{HYST}} \right) V_{CC}$$

When the output of the comparator is low, the supply current increases. The output stage has biasing circuitry to monitor the output current. When the amplifier is used as a comparator, the output stage is overdriven and the current through the biasing circuitry increases to maximum. For the MAX4291, typical supply currents increase to 1.5mA with  $V_{CC} = 1.8V$  and to 9mA when  $V_{CC} = 5.0V$  (Figure 10).

### Using the MAX4291/MAX4292/MAX4294 as Low-Power Current Monitors

The MAX4291/MAX4292/MAX4294 are ideal for applications powered from a two-cell battery stack. Figure 11 shows an application circuit in which the MAX4291 is used for monitoring the current of a two-cell battery stack. In this circuit, a current load is applied, and the voltage drop at the battery terminal is sensed.

The voltage on the load side of the battery stack is equal to the voltage at the emitter of Q1 due to the feedback loop containing the op amp. As the load current increases, the voltage drop across R1 and R2 increases. Thus, R2 provides a fraction of the load current (set by the ratio of R1 and R2) that flows into the

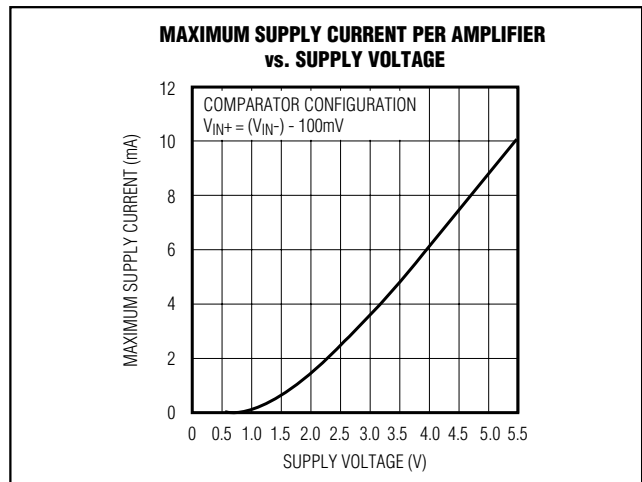

Figure 10. Maximum Supply Current per Amplifier vs. Supply Voltage

emitter of the PNP transistor. Neglecting PNP base current, this current flows into R3, producing a ground-referenced voltage proportional to the load current. To minimize errors, scale R1 to give a voltage drop that is large enough in comparison to the op amp's  $V_{OS}$ .

Calculate the output voltage of the application using the following equation:

$$V_{OUT} = \left[ I_{LOAD} \times \left( \frac{R1}{R2} \right) \right] \times R3$$

# Ultra-Small, 1.8V, $\mu$ Power, Rail-to-Rail I/O Op Amps

MAX4291/MAX4292/MAX4294

For a 1V output and a current load of 50mA, the choice of resistors can be  $R1 = 2\Omega$ ,  $R2 = 100k\Omega$ , and  $R3 = 1M\Omega$ .

## UCSP Information

### Layout Issues

Design the layout for the IC to be as compact as possible to minimize parasitics. The UCSP uses a bump pitch of 0.5mm (19.7mil) and bump diameter of 0.3 (~12mil). Therefore, lay out the solder-pad spacing on 0.5mm (19.7mil) centers, using a pad size of 0.25mm (~10mil) and a solder mask opening of 0.33mm (13mil). Round or square pads are permissible. Connect multiple vias from the ground plane as close to the ground pins as possible.

Install capacitors as close as possible to the IC supply voltage pin. Place the ground end of these capacitors near the IC GND pins to provide a low-impedance return path for the signal current.

### Prototype Chip Installation

Alignment keys on the PC board, around the area where the chip is located, will be helpful in the prototype assembly process. It is better to align the chip on the board before any other components are placed, and then place the board on a hot plate or hot surface until the solder starts melting. Remove the board from the hot plate without disturbing the position of the chip and let it cool down to room temperature before processing the board further.

### UCSP Reliability

The UCSP represents a unique packaging form factor that may not perform as well as a packaged product through traditional mechanical reliability tests. UCSP reliability is integrally linked to the user's assembly methods, circuit board material, and usage environment. The user should closely review these areas when considering use of a UCSP.

Performance through operating-life test and moisture resistance remains uncompromised. The wafer-fabrication process primarily determines the performance. Mechanical stress performance is a greater consideration for UCSPs. UCSPs are attached through direct solder contact to the user's PC board, foregoing the inherent stress relief of a packaged product lead frame. Solder-joint contact integrity must be considered. Comprehensive reliability tests have been performed and are available upon request. In conclusion, the UCSP performs reliably through environmental stresses.

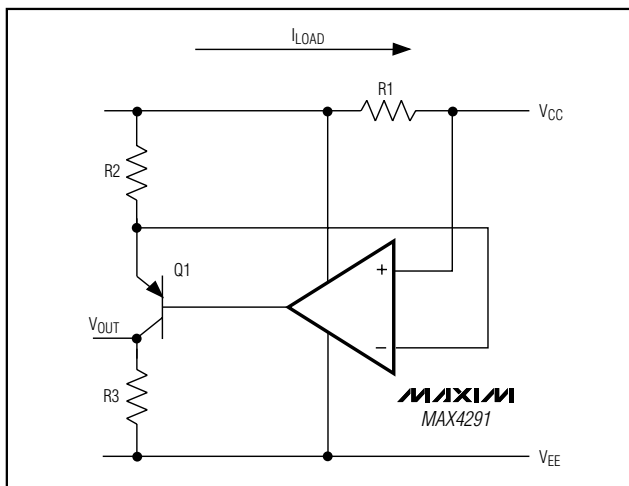
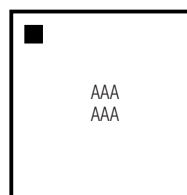

Figure 11. Current Monitor for a 2-Cell Battery Stack

### Marking Information



ORIENTATION  
PRODUCT ID CODE  
LOT CODE

# Ultra-Small, 1.8V, $\mu$ Power, Rail-to-Rail I/O Op Amps

## Pin Configurations (continued)

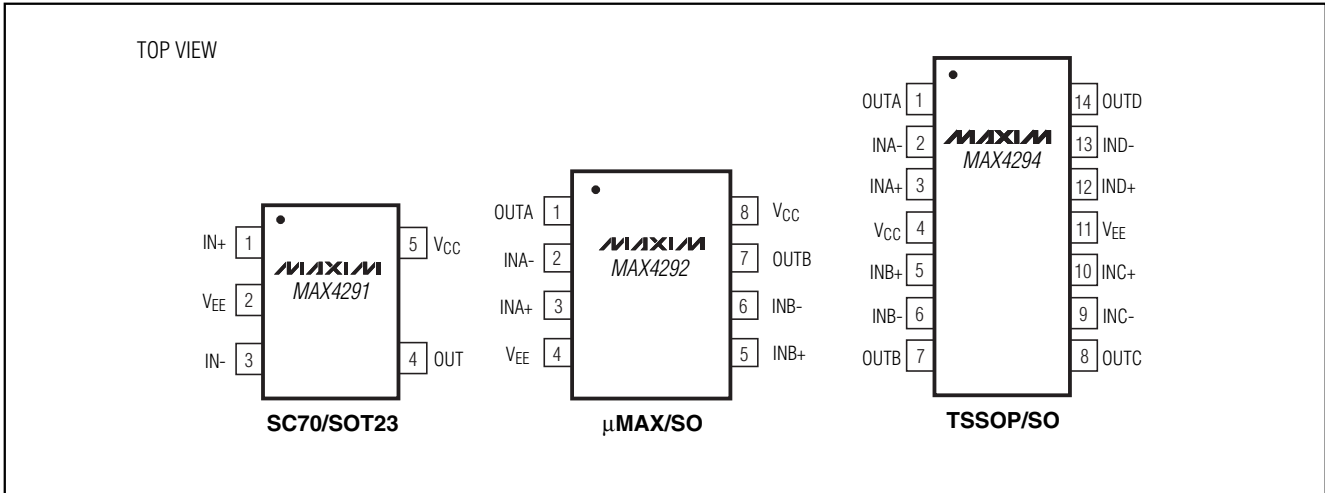

### Chip Information

MAX4291 TRANSISTOR COUNT: 149  
 MAX4292 TRANSISTOR COUNT: 356  
 MAX4294 TRANSISTOR COUNT: 747  
 PROCESS: BiCMOS

# Ultra-Small, 1.8V, $\mu$ Power, Rail-to-Rail I/O Op Amps

## Package Information

(The package drawing(s) in this data sheet may not reflect the most current specifications. For the latest package outline information, go to [www.maxim-ic.com/packages](http://www.maxim-ic.com/packages).)

MAX4291/MAX4292/MAX4294

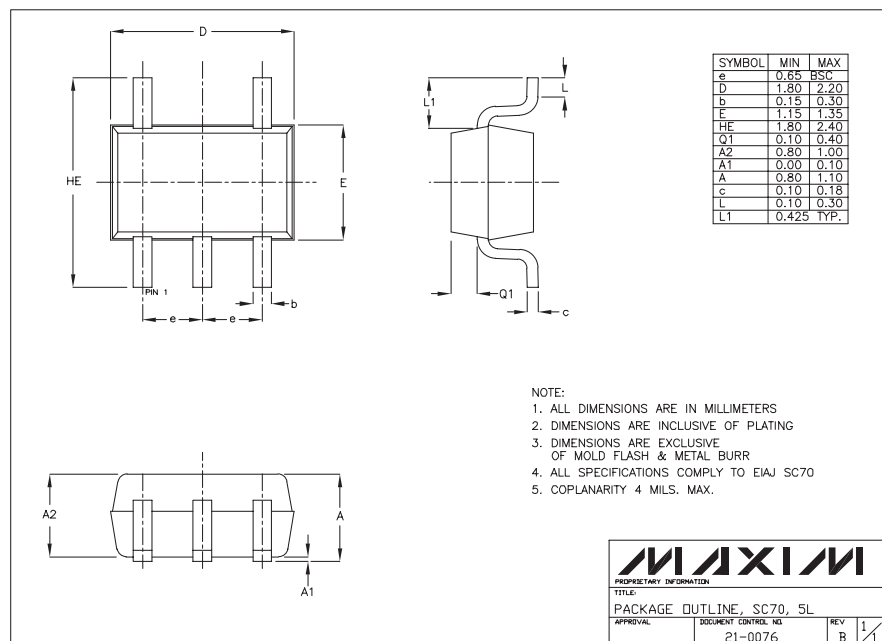
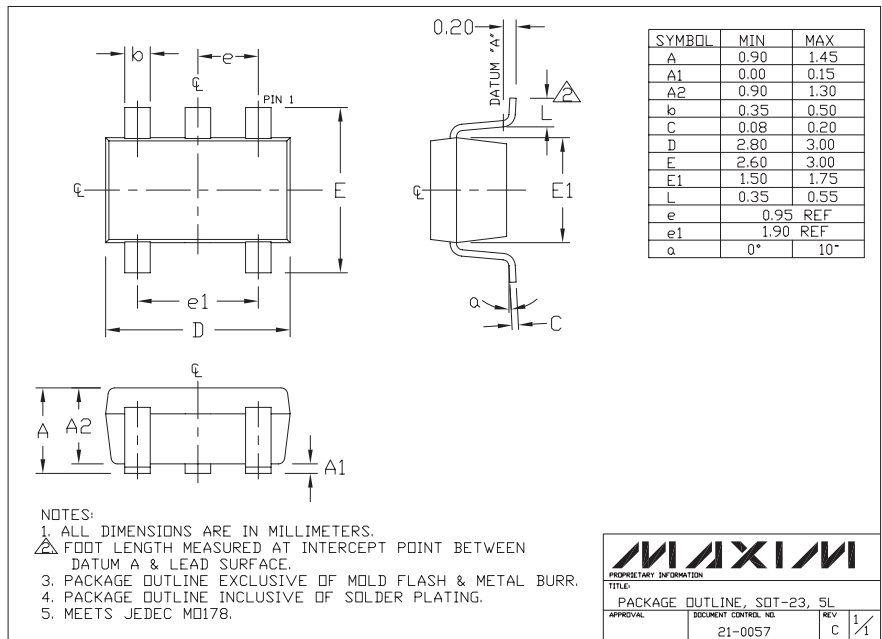

# Ultra-Small, 1.8V, $\mu$ Power, Rail-to-Rail I/O Op Amps

## Package Information (continued)

(The package drawing(s) in this data sheet may not reflect the most current specifications. For the latest package outline information, go to [www.maxim-ic.com/packages](http://www.maxim-ic.com/packages).)

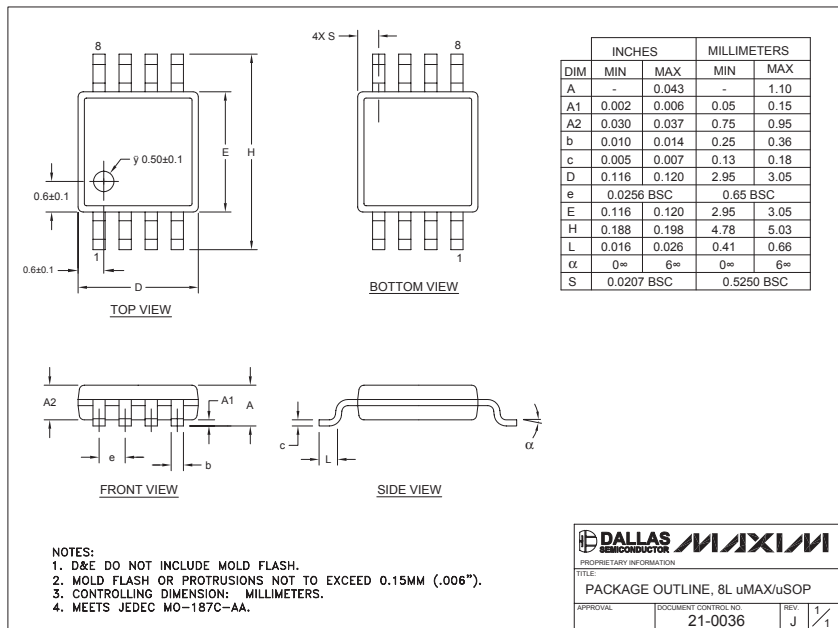

Note: The MAX4292 does not have an exposed pad.

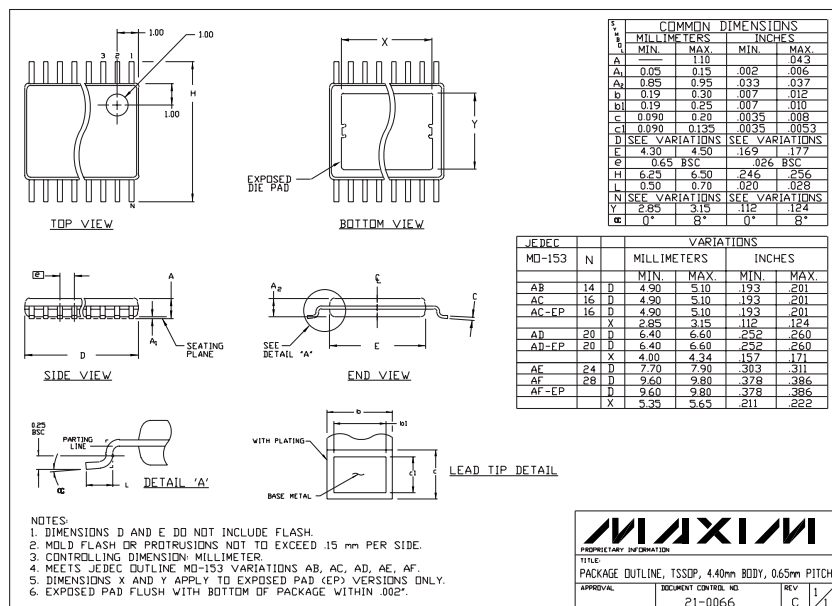

Note: The MAX4294 does not have an exposed pad.

# Ultra-Small, 1.8V, $\mu$ Power, Rail-to-Rail I/O Op Amps

## Package Information (continued)

(The package drawing(s) in this data sheet may not reflect the most current specifications. For the latest package outline information, go to [www.maxim-ic.com/packages](http://www.maxim-ic.com/packages).)

MAX4291/MAX4292/MAX4294

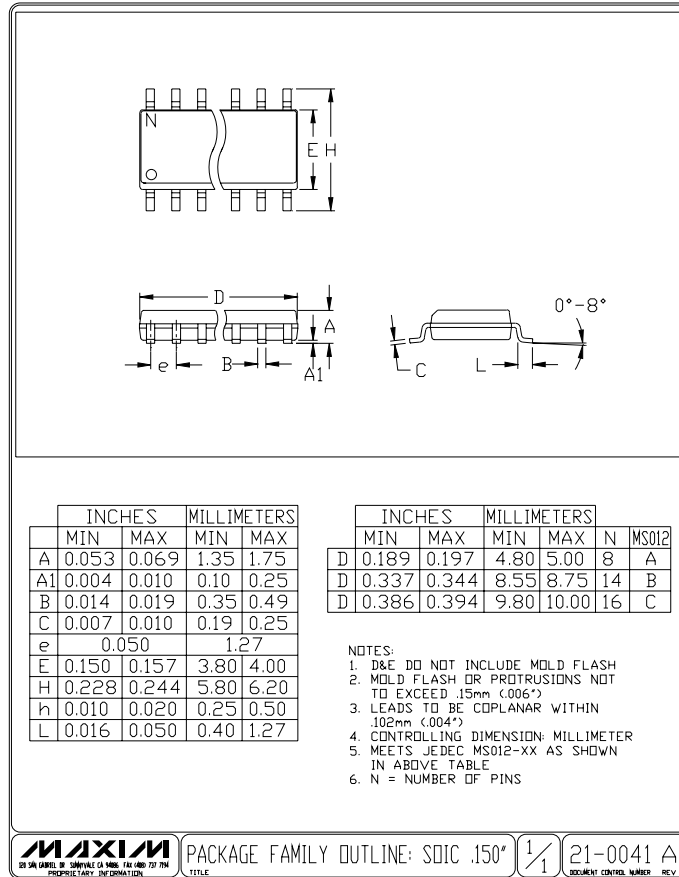

# Ultra-Small, 1.8V, $\mu$ Power, Rail-to-Rail I/O Op Amps

## Package Information (continued)

(The package drawing(s) in this data sheet may not reflect the most current specifications. For the latest package outline information, go to [www.maxim-ic.com/packages](http://www.maxim-ic.com/packages).)

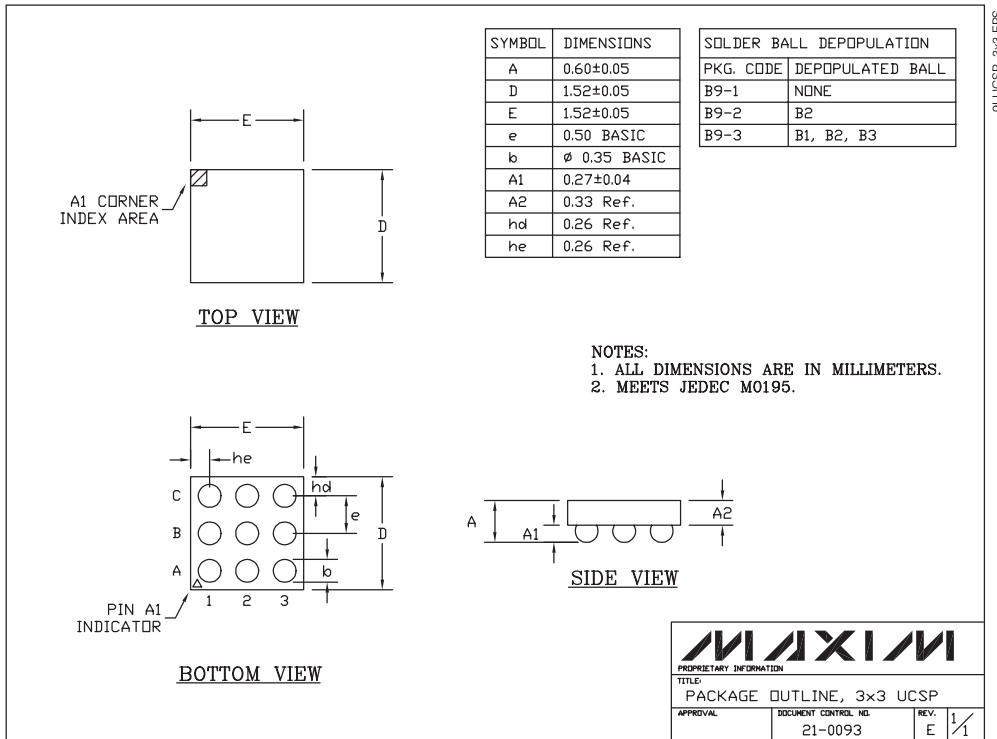

91UCSP-3x3.EPS

Maxim cannot assume responsibility for use of any circuitry other than circuitry entirely embodied in a Maxim product. No circuit patent licenses are implied. Maxim reserves the right to change the circuitry and specifications without notice at any time.

18 \_\_\_\_\_ **Maxim Integrated Products, 120 San Gabriel Drive, Sunnyvale, CA 94086 408-737-7600**

## Looking for pricing, stock, or lifecycle information?

Click below to explore more details on WIN SOURCE:

- ⊖ [View MAX4292EUA+T on WIN SOURCE](#)
- ⊖ [Maxim Integrated Information](#)

## Optimize Your Supply Chain with WIN SOURCE Solutions

- ✓ Global Sourcing Solution
- ✓ Obsolete Management
- ✓ Cost Control Management
- ✓ Shortage Management
- ✓ Alternative Solution
- ✓ Excess Inventory Management