



THE DATASHEET OF MAX4675EUT





3Ω Single SPST Analog Switches

MAX4675/MAX4676

General Description

The MAX4675/MAX4676 single analog switches feature 3Ω (max) on-resistance (RON) and 0.7Ω flatness when operating from dual ±5V supplies. These switches can handle Rail-to-Rail® analog signals. Off-leakage current is 0.1nA at TA = +25°C. The MAX4675/MAX4676 are ideal in low-distortion applications and are the preferred solution over mechanical relays in automated test equipment or applications where current switching is required. They are more reliable than mechanical relays, have low power requirements (<1μA), and are available in a space-saving 6-pin SOT23 package.

The MAX4675 has a single normally open (NO) switch, and the MAX4676 has a single normally closed (NC) switch.

The MAX4675/MAX4676 operate from either a single +2.7V to +5.5V or dual ±2.7V to ±5.5V supplies, making them ideal for use in digital card applications and single-ended 75Ω systems.

Features

- ◆ 3Ω (max) RON
- ◆ 0.7Ω (max) RON Flatness
- ◆ Dual ±2.7V to ±5.5V or Single +2.7V to +5.5V Supply Range
- ◆ Off-Isolation
 - 75dB at 1MHz, Dual Supply
 - 65dB at 1MHz, Single Supply
- ◆ -3dB Bandwidth 250MHz
- ◆ Rail-to-Rail Signal Handling

Applications

- Reed Relay Replacement
- Test Equipment
- Communications Systems
- PBX, PABX Systems
- Audio Signal Routing
- Avionics
- ADC Systems
- Data-Acquisition Systems

Ordering Information

PART	TEMP. RANGE	PIN-PACKAGE	SOT MARK
MAX4675EUT-T	-40°C to +85°C	6 SOT23-6	AAND
MAX4676EUT-T	-40°C to +85°C	6 SOT23-6	AANE

Pin Configurations/Functional Diagrams/Truth Tables

TOP VIEW

SOT23

MAX4675	
IN	SWITCH
0	OFF
1	ON

SOT23

MAX4676	
IN	SWITCH
0	ON
1	OFF

Rail-to-Rail is a registered trademark of Nippon Motorola, Ltd.



For free samples and the latest literature, visit www.maxim-ic.com or phone 1-800-998-8800. For small orders, phone 1-800-835-8769.

3Ω Single SPST Analog Switches

ABSOLUTE MAXIMUM RATINGS

V+ to GND	-0.3V to +6V
V- to GND	+0.3V to -6V
V+ to V-	12V
IN to GND	-0.3V to (V+ + 0.3V)
All Other Pins (Note 1)	(V- - 0.3V) to (V+ + 0.3V)
Continuous Current (NO, NC, COM)	±100mA
Peak Current (NO, NC, COM, pulsed at 1ms (10% duty cycle))	±200mA

Continuous Power Dissipation (T _A = +70°C) 6-Pin SOT23 (derate 8.7mW/°C above +70°C)	691mW
Operating Temperature Range	-40°C to +85°C
Junction Temperature	+150°C
Storage Temperature Range	-65°C to +150°C
Lead Temperature (soldering, 10s)	+300°C

Stresses beyond those listed under "Absolute Maximum Ratings" may cause permanent damage to the device. These are stress ratings only, and functional operation of the device at these or any other conditions beyond those indicated in the operational sections of the specifications is not implied. Exposure to absolute maximum rating conditions for extended periods may affect device reliability.

Note 1: Signals on NO, NC, COM, or IN exceeding V+ or V- will be clamped by internal diodes. Limit forward diode current to maximum current rating.

ELECTRICAL CHARACTERISTICS—DUAL SUPPLIES

(V+ = +5V ±10%, V- = -5V ±10%, GND = 0, V_{IH} = +2.4V, V_{IL} = 0.8V, T_A = T_{MIN} to T_{MAX}, unless otherwise noted. Typical values are at T_A = +25°C.) (Notes 2, 3)

PARAMETER	SYMBOL	CONDITIONS	MIN	TYP	MAX	UNITS	
ANALOG SWITCH							
Input Voltage Range	V _{COM} , V _{NO} , V _{NC}		V-		V+	V	
On-Resistance	R _{ON}	V+ = 4.5V, V- = -4.5V, I _{COM} = 50mA; V _{NO} or V _{NC} = ±3.3V	T _A = +25°C	2.4	3	Ω	
			T _A = T _{MIN} to T _{MAX}		4		
On-Resistance Flatness (Note 4)	R _{FLAT}	V+ = 4.5V, V- = -4.5V, I _{COM} = 50mA; V _{NO} or V _{NC} = ±3.3V, 0	T _A = +25°C	0.4	0.7	Ω	
			T _A = T _{MIN} to T _{MAX}		1.0		
NC or NO Off-Leakage Current	I _{N(OFF)}	V+ = 5.5V, V- = -5.5V, V _{COM} = 4.5V; V _{NO} or V _{NC} = ±4.5V	T _A = +25°C	-1	0.1	1	nA
			T _A = T _{MIN} to T _{MAX}	-10		10	
COM Off-Leakage Current	I _{COM(OFF)}	V+ = 5.5V, V- = -5.5V, V _{COM} = +4.5V; V _{NO} or V _{NC} = ±4.5V	T _A = +25°C	-1	0.1	1	nA
			T _A = T _{MIN} to T _{MAX}	-10		10	
COM On-Leakage Current	I _{COM(ON)}	V+ = 5.5V, V- = -5.5V, V _{COM} = ±4.5V; V _{NO} or V _{NC} = ±4.5V or floating	T _A = +25°C	-2	0.1	2	nA
			T _A = T _{MIN} to T _{MAX}	-20		20	
LOGIC INPUT							
Input Low Voltage	V _{IL}				0.8	V	
Input High Voltage	V _{IH}		2.4			V	
Input Leakage Current	I _{IN}		-1	0.005	1	μA	
DYNAMIC							
Turn-On Time	t _{ON}	V+ = +4.5V, V- = -4.5V; V _{NO} or V _{NC} = 3.3V, R _L = 300Ω, C _L = 35pF, Figure 2	T _A = +25°C	135	300	ns	
			T _A = T _{MIN} to T _{MAX}		375		
Turn-Off Time	t _{OFF}	V+ = +4.5V, V- = -4.5V; V _{NO} or V _{NC} = 3.3V, R _L = 300Ω, C _L = 35pF, Figure 2	T _A = +25°C	50	110	ns	
			T _A = T _{MIN} to T _{MAX}		125		

3Ω Single SPST Analog Switches

MAX4675/MAX4676

ELECTRICAL CHARACTERISTICS—DUAL SUPPLIES (continued)

(V+ = +5V ±10%, V- = -5V ±10%, GND = 0, VIH = +2.4V, VIL = 0.8V, TA = TMIN to TMAX, unless otherwise noted. Typical values are at TA = +25°C.) (Notes 2, 3)

PARAMETER	SYMBOL	CONDITIONS		MIN	TYP	MAX	UNITS
Charge Injection	Q	RGEN = 0Ω, CL = 1nF, VGEN = 0, Figure 3	TA = +25°C		87		pC
Off-Isolation	VISO	RL = 50Ω, CL = 5pF, f = 1MHz, Figure 4	TA = +25°C		-75		dB
On-Channel Bandwidth (-3dB)	BW	RS = 50Ω, RL = 50Ω			250		MHz
NC or NO Off-Capacitance	C(N_OFF)	f = 1MHz, Figure 5	TA = +25°C		85		pF
COM Off-Capacitance	C(COMOFF)	f = 1MHz, Figure 5	TA = +25°C		85		pF
On-Capacitance	C(ON)	f = 1MHz, Figure 5	TA = +25°C		350		pF
POWER SUPPLY							
Supply Voltage	V+, V-			±2.7		±5.5	V
Positive Supply Current	I+	VIN = 0 or 5.5V, V+ = 5.5V, V- = -5.5V	TA = +25°C		0.002	1	μA
			TA = TMIN to TMAX			10	
Negative Supply Current	I-	VIN = 0 or 5.5V, V+ = 5.5V, V- = -5.5V	TA = +25°C	-1	-0.002		μA
			TA = TMIN to TMAX	-10			

ELECTRICAL CHARACTERISTICS—SINGLE SUPPLY

(V+ = +5V ±10%, V- = 0, GND = 0, VIH = +2.4V, VIL = 0.8V, TA = TMIN to TMAX, unless otherwise noted. Typical values are at TA = +25°C.) (Notes 2, 3)

PARAMETER	SYMBOL	CONDITIONS		MIN	TYP	MAX	UNITS
ANALOG SWITCH							
Input Voltage Range	VCOM, VNO, VNC			0		V+	V
On-Resistance	RON	V+ = 4.5V; ICOM = 50mA; VNO or VNC = 3.3V	TA = +25°C		3.5	5.75	Ω
			TA = TMIN to TMAX			7.5	
On-Resistance Flatness (Note 4)	RFLAT	V+ = 4.5V; ICOM = 50mA; VNO or VNC = 1.5V, 2.5V, 3.3V	TA = +25°C		0.4	1.6	Ω
			TA = TMIN to TMAX			2	
NC or NO Off-Leakage Current	IN_(OFF)	V+ = 5.5V; VNO or VNC = 4.5V or 0; VCOM = 0 or 4.5V	TA = +25°C	-1	0.1	1	nA
			TA = TMIN to TMAX	-10		10	
COM Off-Leakage Current	ICOM(OFF)	V+ = 5.5V; VNO or VNC = 4.5V or 0; VCOM = 0 or 4.5V	TA = +25°C	-1	0.1	1	nA
			TA = TMIN to TMAX	-10		10	

3Ω Single SPST Analog Switches

ELECTRICAL CHARACTERISTICS—SINGLE SUPPLY (continued)

(V+ = +5V ±10%, V- = 0, GND = 0, V_{IH} = +2.4V, V_{IL} = 0.8V, T_A = T_{MIN} to T_{MAX}, unless otherwise noted. Typical values are at T_A = +25°C.) (Notes 2, 3)

PARAMETER	SYMBOL	CONDITIONS	MIN	TYP	MAX	UNITS	
COM On-Leakage Current	I _{COM (ON)}	V+ = 5.5V; V _{NO} or V _{NC} = 0, 4.5V, or floating; V _{COM} = 0 or 4.5V	T _A = +25°C	-2	0.2	2	nA
			T _A = T _{MIN} to T _{MAX}	-20		20	
LOGIC INPUT							
Input Low Voltage	V _{IL}				0.8	V	
Input High Voltage	V _{IH}		2.4			V	
Input Leakage Current	I _{IN}		-1	0.005	1	μA	
DYNAMIC							
Turn-On Time	t _{ON}	V+ = +4.5V; V _{NO} or V _{NC} = +3.3V, R _L = 300Ω, C _L = 35pF, Figure 2	T _A = +25°C	350	700	ns	
			T _A = T _{MIN} to T _{MAX}		850		
Turn-Off Time	t _{OFF}	V+ = +4.5V; V _{NO} or V _{NC} = +3.3V, R _L = 300Ω, C _L = 35pF, Figure 2	T _A = +25°C	55	150	ns	
			T _A = T _{MIN} to T _{MAX}		160		
Charge Injection	Q	R _{GEN} = 0Ω, C _L = 1nF, V _{GEN} = 2.5V, Figure 3	T _A = +25°C	31		pC	
Off-Isolation	V _{ISO}	R _L = 50Ω, C _L = 5pF, f = 1MHz, Figure 4	T _A = +25°C	-65		dB	
On-Channel Bandwidth (-3dB)		R _S = 50Ω, R _L = 50Ω		150		MHz	
NC or NO Off-Capacitance	C _(N_OFF)	f = 1MHz, Figure 5	T _A = +25°C	85		pF	
COM Off-Capacitance	C _(COMOFF)	f = 1MHz, Figure 5	T _A = +25°C	85		pF	
On-Capacitance	C _(ON)	f = 1MHz, Figure 5	T _A = +25°C	350		pF	
POWER SUPPLY							
Supply Voltage	V+		2.7		5.5	V	
Positive Supply Current	I+	V _{IN} = 0 or 5V, V+ = 5.5V	T _A = +25°C	0.002	1	μA	
			T _A = T _{MIN} to T _{MAX}		10		

Note 2: Parameters are 100% tested at +25°C only and guaranteed by correlation through the full-rated temperature range.

Note 3: The algebraic convention, where the most negative value is a minimum and the most positive value a maximum, is used in this data sheet.

Note 4: Flatness is defined as the difference between the maximum and minimum value of R_{ON} as measured over the specified analog signal ranges.

3Ω Single SPST Analog Switches

Typical Operating Characteristics

($T_A = +25^\circ\text{C}$, unless otherwise noted.)

MAX4675/MAX4676

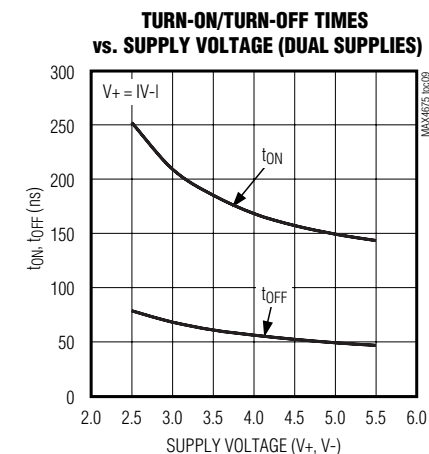
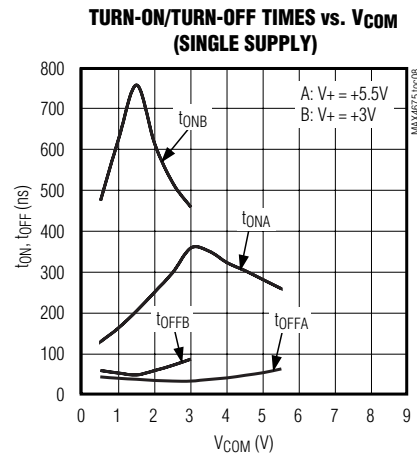
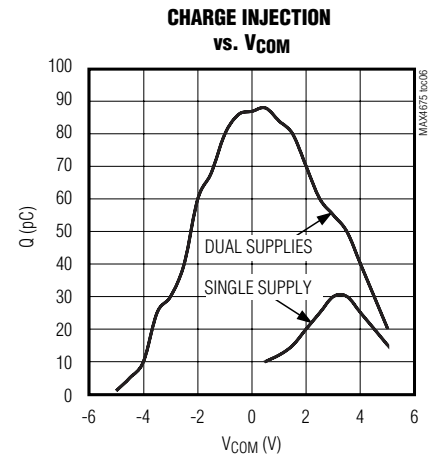
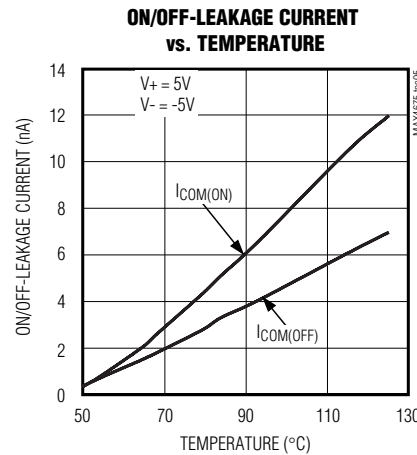
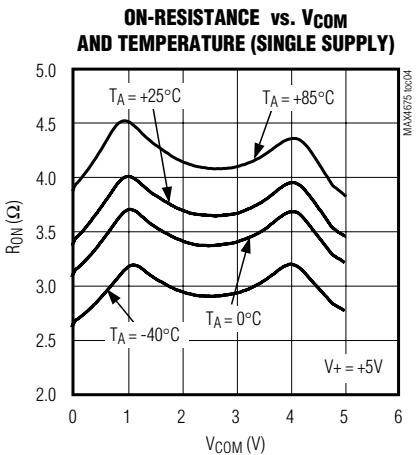
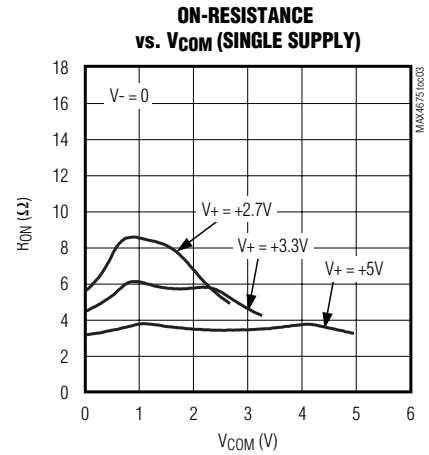
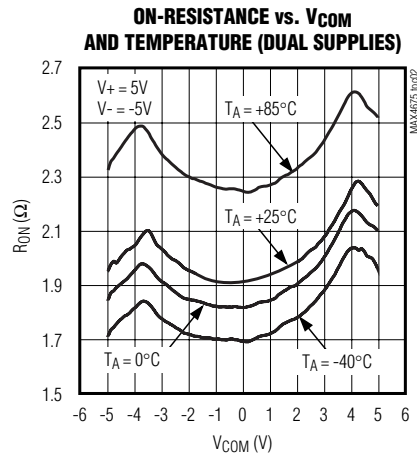
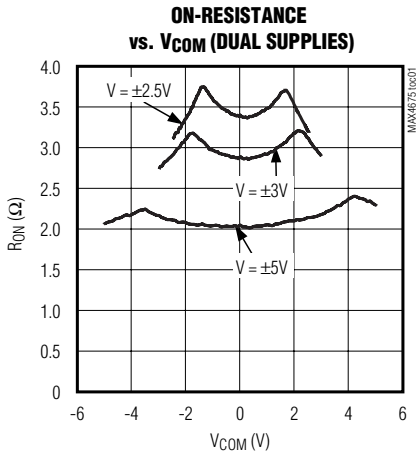

3Ω Single SPST Analog Switches

Typical Operating Characteristics (continued)

(T_A = +25°C, unless otherwise noted.)

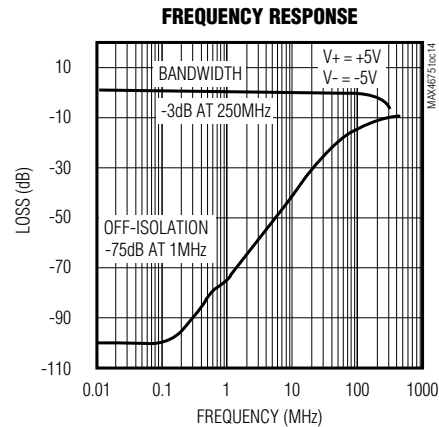
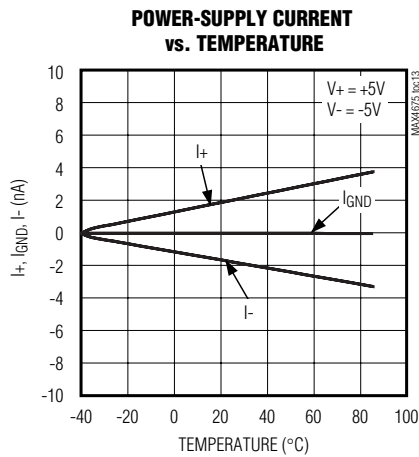
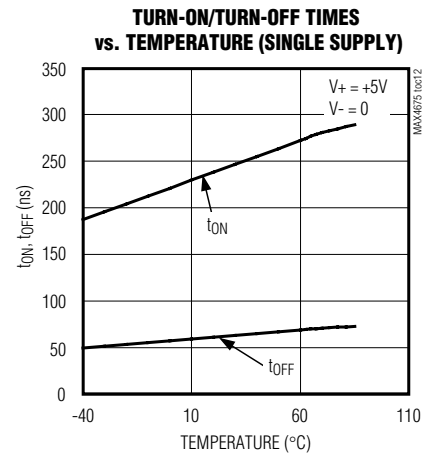
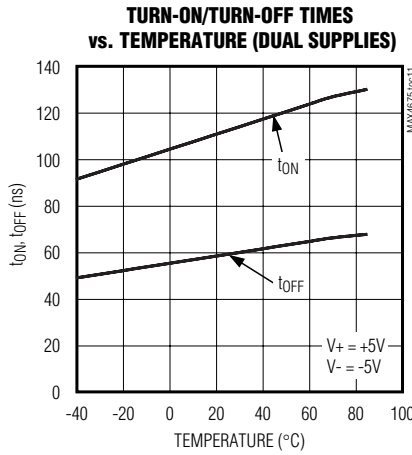
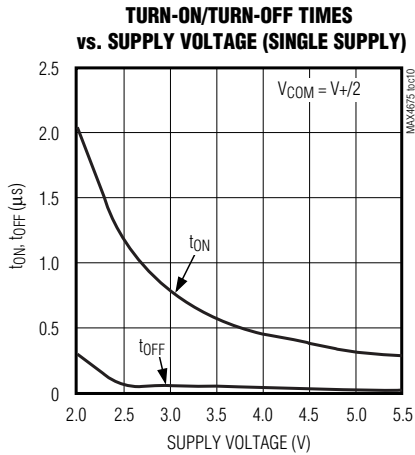

Pin Description

PIN		NAME	FUNCTION
MAX4675	MAX4676		
1	1	V+	Positive Supply
2	2	COM	Analog Switch Common Terminals
3	3	V-	Negative Supply
4	4	GND	Ground
5	—	NO	Analog Switch Normally Open Terminal
—	5	NC	Analog Switch Normally Closed Terminal
6	6	IN	Logic Input

3Ω Single SPST Analog Switches

Applications Information

Overvoltage Protection

Proper power-supply sequencing is recommended for all CMOS devices. Do not exceed the absolute maximum ratings because stresses beyond the listed ratings can cause permanent damage to the devices. Always sequence V+ on first, then V-, followed by the logic inputs, NO, NC, or COM. If proper power-supply sequencing is not possible, add two small-signal diodes (D1, D2) in series with the supply pins (Figure 1). Adding diodes reduces the analog signal range to one diode drop below V+ and one diode drop above V- but does not affect the devices' low switch resistance and low leakage characteristics. Device operation is unchanged, and the difference between V+ and V- should not exceed 12V.

Power-supply bypassing improves noise margin and prevents switching noise from propagating from the V+ supply to other components. A 0.1μF capacitor connected from V+ to GND is adequate for most applications.

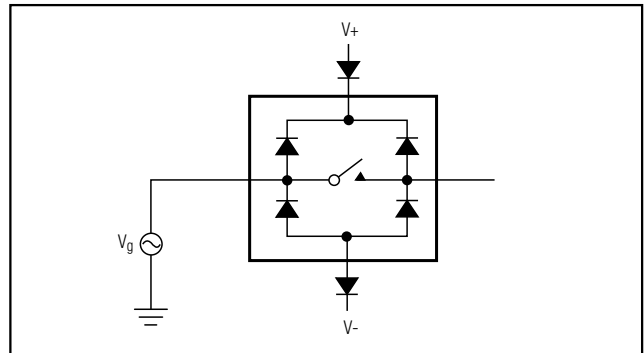

Figure 1. Overvoltage Protection Using External Blocking Diodes

Timing Diagrams/Test Circuits

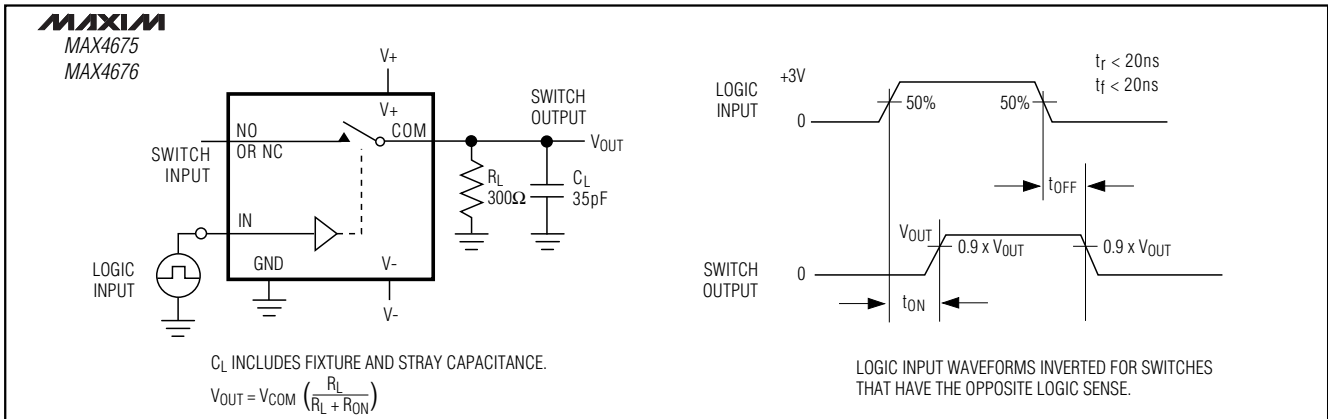

Figure 2. Switching Time

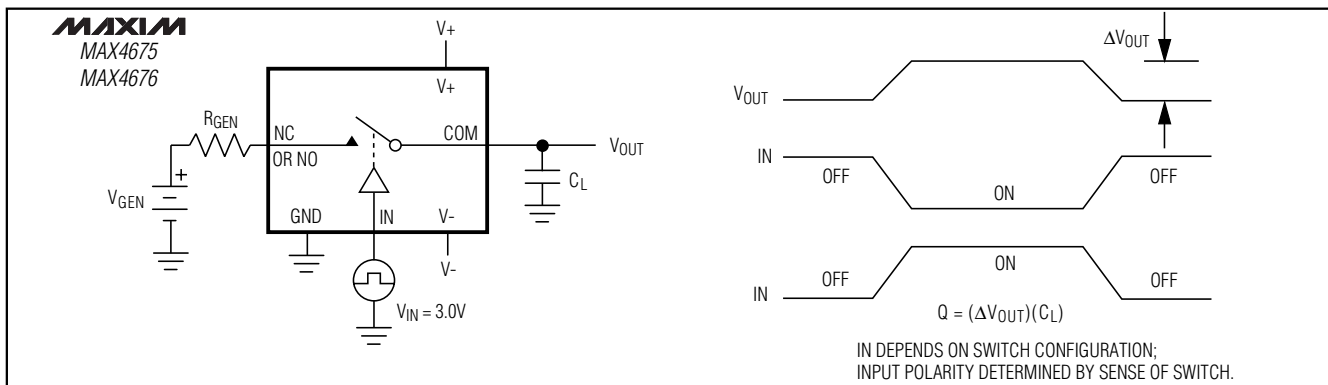

Figure 3. Charge Injection

3Ω Single SPST Analog Switches

Timing Diagrams/Test Circuits (continued)

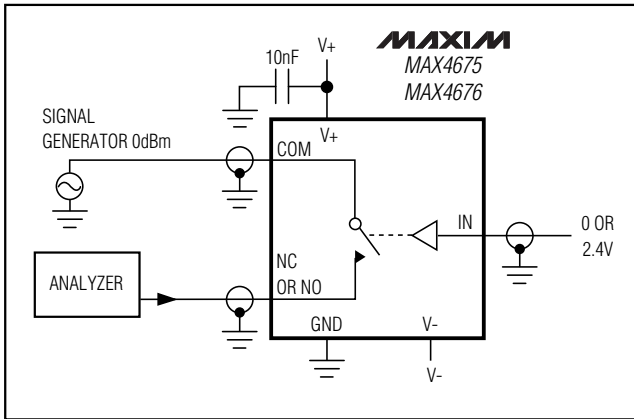

Figure 4. Off-Isolation/On-Channel Bandwidth

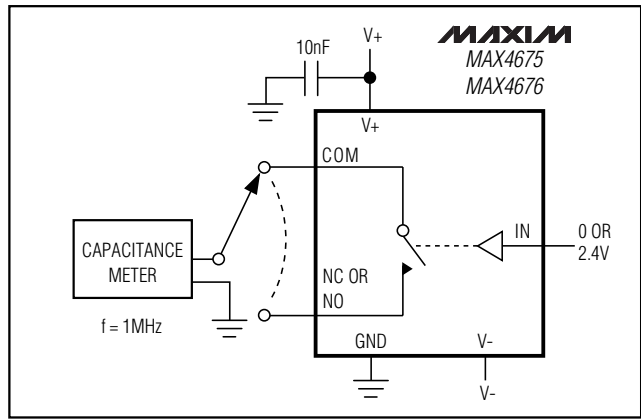
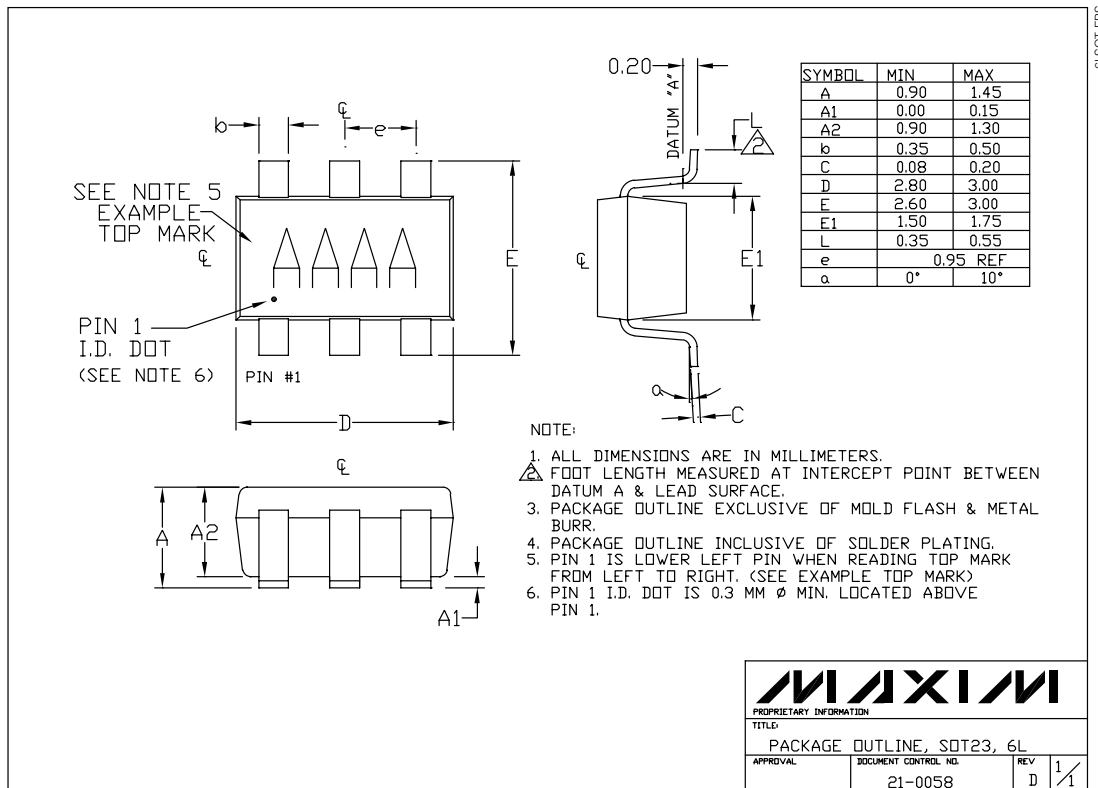

Figure 5. Channel On/Off-Capacitance

Package Information



Maxim cannot assume responsibility for use of any circuitry other than circuitry entirely embodied in a Maxim product. No circuit patent licenses are implied. Maxim reserves the right to change the circuitry and specifications without notice at any time.

8 Maxim Integrated Products, 120 San Gabriel Drive, Sunnyvale, CA 94086 408-737-7600

Looking for pricing, stock, or lifecycle information?

Click below to explore more details on WIN SOURCE:

 [View MAX4675EUT](#) on WIN SOURCE

 [Maxim Integrated](#) Information

Optimize Your Supply Chain with WIN SOURCE Solutions

-  Global Sourcing Solution
-  Obsolete Management
-  Cost Control Management
-  Shortage Management
-  Alternative Solution
-  Excess Inventory Management