



**THE DATASHEET OF
MAX4704EUB+T**





Low-Voltage, 60Ω, 4:1 Analog Multiplexer in QFN

MAX4704

General Description

The MAX4704 low-voltage, 4-channel analog multiplexer operates from a single +1.8V to +5.5V supply. The MAX4704 features break-before-make switching action with a $t_{ON} = 60\text{ns}$ and $t_{OFF} = 20\text{ns}$ at +3V.

When powered from a +2.7V supply, the device has a 60Ω (max) on-resistance (R_{ON}), with 3Ω (max) R_{ON} matching and 5Ω max R_{ON} flatness. The digital logic inputs are 1.8V-logic compatible from a +2.7V to +3.3V supply. The MAX4704 is available in both a space-saving 12-pin QFN (3mm x 3mm) package and a 10-pin μMAX package.

Applications

MP3 Players
Battery-Operated Equipment
Relay Replacement
Audio and Video Signal Routing
Low-Voltage Data-Acquisition Systems
Communications Circuits
PCMCIA Cards
Cellular Phones
Modems

Features

- ◆ 3mm x 3mm 12-Pin QFN Package
- ◆ Guaranteed On-Resistance:
60Ω (max) (+2.7V Supply)
40Ω (max) (+5V Supply)
- ◆ Guaranteed Match Between Channels: 3Ω (max)
- ◆ Guaranteed Flatness Over Signal Range:
5Ω (max)
- ◆ Guaranteed Low Leakage Currents:
100pA (max) at +25°C
- ◆ Switching Time: $t_{ON} = 60\text{ns}$, $t_{OFF} = 20\text{ns}$
- ◆ +1.8V to +5.5V Single-Supply Operation
- ◆ Rail-to-Rail Signal Handling
- ◆ -3dB Bandwidth: >200MHz
- ◆ Low Crosstalk: -90dB (1MHz)
- ◆ High Off-Isolation: -85dB (1MHz)
- ◆ Low 3pC Charge Injection
- ◆ THD: 0.02%
- ◆ +1.8V CMOS-Logic Compatible

Ordering Information

PART	TEMP. RANGE	PIN-PACKAGE
MAX4704EGC	-40°C to +85°C	12 QFN-EP*
MAX4704EUB	-40°C to +85°C	10 μMAX

*EP = Exposed Pad

Pin Configurations

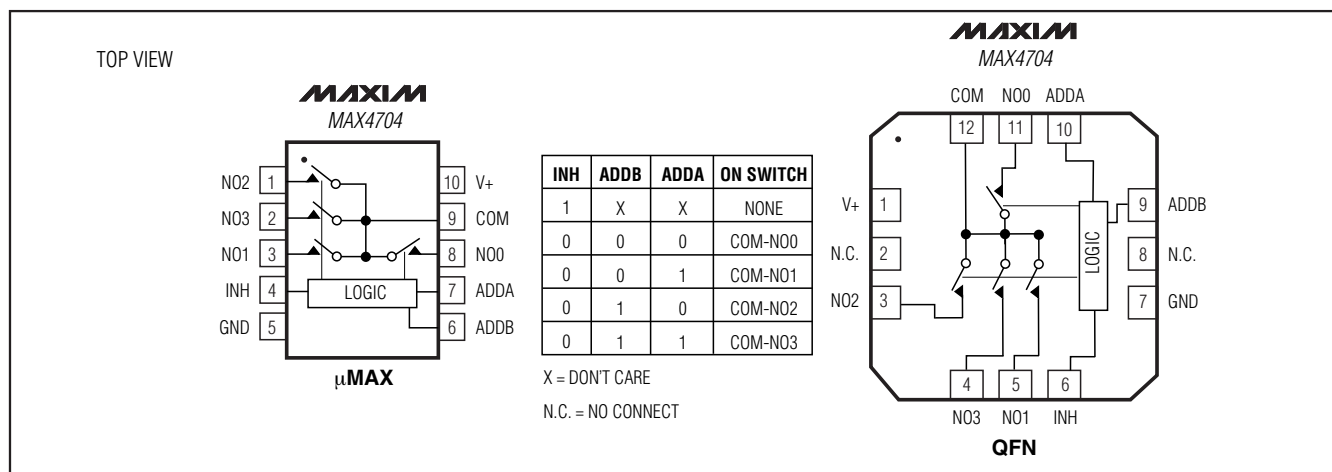

Low-Voltage, 60Ω, 4:1 Analog Multiplexer in QFN

ABSOLUTE MAXIMUM RATINGS

(Voltages Referenced to GND)

V+	-0.3V to +6V
All Other Pins (Note 1).....	-0.3V to (V+ + 0.3V)
Continuous Current COM, NO_	±20mA
Peak Current COM, NO_ (pulsed at 1ms, 10% duty cycle).....	±40mA
ESD per Method 3015.7.....	>2kV

Continuous Power Dissipation (T_A = +70°C)

10-Pin μMAX (derate 4.7mW/°C above +70°C)	330mW
12-Pin QFN (derate 11.9mW/°C above +70°C)	952mW
Operating Temperature Range	-40°C to +85°C
Storage Temperature Range	-65°C to +150°C
Lead Temperature (soldering, 10s)	+300°C

Note 1: Signals on INH, ADD_, NO_, and COM exceeding V+ or GND are clamped by internal diodes. Limit forward-diode current to maximum current rating.

Stresses beyond those listed under "Absolute Maximum Ratings" may cause permanent damage to the device. These are stress ratings only, and functional operation of the device at these or any other conditions beyond those indicated in the operational sections of the specifications is not implied. Exposure to absolute maximum rating conditions for extended periods may affect device reliability.

ELECTRICAL CHARACTERISTICS—Single +3V Supply

(V+ = +2.7V to +3.3V, V_{IH} = +1.4V, V_{IL} = +0.5V, T_A = -40°C to +85°C, unless otherwise noted. Typical values are at V+ = +3V and T_A = +25°C.) (Notes 2, 3)

PARAMETER	SYMBOL	CONDITIONS	T _A	MIN	TYP	MAX	UNITS
ANALOG SWITCH							
Analog Signal Range	V _{COM} , V _{NO_}			0		V+	V
On-Resistance	R _{ON}	V+ = +2.7V, I _{COM} = 5mA, V _{NO_} = +1.3V	+25°C		50	60	Ω
			T _{MIN} to T _{MAX}			70	
On-Resistance Match Between Channels (Note 4)	ΔR _{ON}	V+ = +2.7V, I _{COM} = 5mA, V _{NO_} = +1.3V	+25°C		1	3	Ω
			T _{MIN} to T _{MAX}			5	
On-Resistance Flatness (Note 5)	R _{FLAT (ON)}	V+ = +2.7V, I _{COM} = 5mA, V _{NO_} = +1V, +1.3V, +1.8V	+25°C		3	5	Ω
			T _{MIN} to T _{MAX}			10	
NO_ Off-Leakage Current (Note 6)	I _{NO_(OFF)}	V+ = +3.3V, V _{COM} = +0.3V, +3V V _{NO_} = +3V, +0.3V	+25°C	-0.1	±0.01	0.1	nA
			T _{MIN} to T _{MAX}	-1		1	
COM On-Leakage Current (Note 6)	I _{COM(ON)}	V+ = +3.3V, V _{COM} = +0.3V, +3V V _{NO_} = +0.3V, +3V, or floating	+25°C	-0.5	±0.01	0.5	nA
			T _{MIN} to T _{MAX}	-5		5	
COM Off-Leakage Current (Note 6)	I _{COM(OFF)}	V+ = +3.3V, V _{COM} = +0.3V, +3V V _{NO_} = +3V, +0.3V	+25°C	-0.5	±0.01	0.5	nA
			T _{MIN} to T _{MAX}	-5		5	
DYNAMIC							
Address Transition Time	t _{TRANS}	V _{NO_} = +1.5V, R _L = 300Ω, C _L = 35pF, Figure 2	+25°C		20	60	ns
			T _{MIN} to T _{MAX}			70	
Inhibit Turn-On Time	t _{ON}	V _{NO_} = +1.5V, R _L = 300Ω, C _L = 35pF, Figure 3	+25°C		25	60	ns
			T _{MIN} to T _{MAX}			70	
Inhibit Turn-Off Time	t _{OFF}	V _{NO_} = +1.5V, R _L = 300Ω, C _L = 35pF, Figure 3	+25°C		10	20	ns
			T _{MIN} to T _{MAX}			30	
Break-Before-Make Time (Note 7)	t _{BBM}	V _{NO_} = +1.5V, R _L = 300Ω, C _L = 35pF, Figure 4	+25°C		20		ns
			T _{MIN} to T _{MAX}	2			
Charge Injection	Q	V _{GEN} = 0, R _{GEN} = 0, C _L = 1.0nF, Figure 5			2		pC

Low-Voltage, 60Ω, 4:1 Analog Multiplexer in QFN

MAX4704

ELECTRICAL CHARACTERISTICS—Single +3V Supply (continued)

(V+ = +2.7V to +3.3V, V_{IH} = +1.4V, V_{IL} = +0.5V, T_A = -40°C to +85°C, unless otherwise noted. Typical values are at V+ = +3V and T_A = +25°C.) (Notes 2, 3)

PARAMETER	SYMBOL	CONDITIONS	T _A	MIN	TYP	MAX	UNITS
On-Channel -3dB Bandwidth	BW	Signal = 0dBm, 50Ω in and out, Figure 6			>200		MHz
Off-Isolation (Note 8)	V _{ISO}	f = 1MHz, R _L = 50Ω, C _L = 5pF, Figure 6			-85		dB
Crosstalk (Note 9)	V _{CT}	f = 1MHz, R _L = 50Ω, C _L = 5pF, Figure 6			-90		dB
NO_ Off-Capacitance	C _{NO_(OFF)}	f = 1MHz, V _{NO_} = GND, Figure 7			7		pF
COM On-Capacitance	C _{COM(ON)}	f = 1MHz, V _{NO_} = GND, Figure 7			19		pF
COM Off-Capacitance	C _{COM(OFF)}	f = 1MHz, V _{NO_} = GND, Figure 7			15		pF
DIGITAL I/O							
Input Logic High	V _{IH}			1.4			V
Input Logic Low	V _{IL}					0.5	V
Input Leakage Current	I _{IH} , I _{IL}	ADD_, INH = 0 or V+		-1		1	μA
SUPPLY							
Power-Supply Range	V+			1.8		5.5	V
Power-Supply Current	I+	V+ = +5.5V, ADD_, INH = 0 or V+				1	μA

ELECTRICAL CHARACTERISTICS—Single +5V Supply

(V+ = +4.5V to +5.5V, V_{IH} = +2.0V, V_{IL} = +0.8V, T_A = -40°C to +85°C, unless otherwise noted. Typical values are at V+ = +5V and T_A = +25°C.) (Notes 2, 3)

PARAMETER	SYMBOL	CONDITIONS	T _A	MIN	TYP	MAX	UNITS
ANALOG SWITCH							
Analog Signal Range	V _{COM} , V _{NO_}			0		V+	V
On-Resistance	R _{ON}	V+ = +4.5V, I _{COM} = 5mA, V _{NO_} = +3.5V	+25°C		30	40	Ω
			T _{MIN} to T _{MAX}			50	
On-Resistance Match Between Channels (Note 4)	ΔR _{ON}	V+ = +4.5V, I _{COM} = 5mA, V _{NO_} = +3.5V	+25°C		1	2	Ω
			T _{MIN} to T _{MAX}			3	
On-Resistance Flatness (Note 5)	R _{FLAT (ON)}	V+ = +4.5V, I _{COM} = 5mA, V _{NO_} = +1V, +2.25V, +3.5V	+25°C		3	5	Ω
			T _{MIN} to T _{MAX}			10	
NO_ Off-Leakage Current (Note 6)	I _{NO_(OFF)}	V+ = +5.5V, V _{COM} = +0.5V, +5V, V _{NO_} = +5V, +0.5V	+25°C	-0.1	±0.01	0.1	nA
			T _{MIN} to T _{MAX}	-1		1	
COM On-Leakage Current (Note 6)	I _{COM(ON)}	V+ = +5.5V, V _{COM} = +0.5V, +5V, V _{NO_} = +0.5V, +5V, or floating	+25°C	-0.5	±0.01	0.5	nA
			T _{MIN} to T _{MAX}	-5		5	

Low-Voltage, 60Ω, 4:1 Analog Multiplexer in QFN

ELECTRICAL CHARACTERISTICS—Single +5V Supply (continued)

(V+ = +4.5V to +5.5V, V_{IH} = +2.0V, V_{IL} = +0.8V, T_A = -40°C to +85°C, unless otherwise noted. Typical values are at V+ = +5V and T_A = +25°C.) (Notes 2, 3)

PARAMETER	SYMBOL	CONDITIONS	T _A	MIN	TYP	MAX	UNITS
COM Off-Leakage Current	I _{COM(OFF)}	V+ = +5.5V, V _{COM_} = +0.5V, +5V V _{NO_} = +5V, +0.5V	+25°C	-0.5	±0.01	0.5	nA
			T _{MIN} to T _{MAX}	-5		5	
DYNAMIC							
Address Transition Time	t _{TRANS}	V _{NO_} = +3V, R _L = 300Ω, C _L = 35pF, Figure 2	+25°C		15	35	ns
			T _{MIN} to T _{MAX}			40	
Inhibit Turn-On Time	t _{ON}	V _{NO_} = +3V, R _L = 300Ω, C _L = 35pF, Figure 3	+25°C		18	35	ns
			T _{MIN} to T _{MAX}			40	
Inhibit Turn-Off Time	t _{OFF}	V _{NO_} = +3V, R _L = 300Ω, C _L = 35pF, Figure 3	+25°C		9	20	ns
			T _{MIN} to T _{MAX}			30	
Break-Before-Make Time (Note 7)	t _{BBM}	V _{NO_} = +3V, R _L = 300Ω, C _L = 35pF, Figure 4	+25°C		20		ns
			T _{MIN} to T _{MAX}		2		
Charge Injection	Q	V _{GEN} = 0, R _{GEN} = 0, C _L = 1.0nF, Figure 5			3		pC
On-Channel -3dB Bandwidth	BW	Signal = 0dBm, 50Ω in and out, Figure 6			>200		MHz
Off-Isolation (Note 8)	V _{ISO}	f = 1MHz, R _L = 50Ω, C _L = 5pF, Figure 6			-85		dB
Crosstalk (Note 9)	V _{CT}	f = 1MHz, R _L = 50Ω, C _L = 5pF, Figure 6			-90		dB
Total Harmonic Distortion	THD	f = 20Hz to 20kHz, 1Vp-p, R _L = 600Ω			0.02		%
DIGITAL I/O							
Input Logic High	V _{IH}			2.0			V
Input Logic Low	V _{IL}					0.8	V
Input Leakage Current	I _{IH} , I _{IL}	ADD ₋ , INH = 0 or V+		-1		1	μA
SUPPLY							
Power-Supply Range	V+			1.8		5.5	V
Positive Supply Current	I+	V+ = +5.5V, ADD ₋ , INH = 0 or V+				1	μA

Note 2: The algebraic convention, where the most negative value is a minimum and the most positive value a maximum, is used in this data sheet.

Note 3: -40°C specifications are guaranteed by design.

Note 4: $\Delta R_{ON} = R_{ON(MAX)} - R_{ON(MIN)}$.

Note 5: Flatness is defined as the difference between the maximum and minimum value of on-resistance as measured over the specified analog signal ranges.

Note 6: Leakage currents are 100% tested at T_A = +85°C. Limits across the full temperature range are guaranteed by correlation.

Note 7: Guaranteed by design.

Note 8: Off-Isolation = $20\log_{10}(V_{COM} / V_{NO_})$, V_{COM} = output, V_{NO_} = input to off switch.

Note 9: Between any two switches.

Low-Voltage, 60Ω, 4:1 Analog Multiplexer in QFN

Typical Operating Characteristics

($T_A = +25^\circ\text{C}$, unless otherwise noted.)

MAX4704

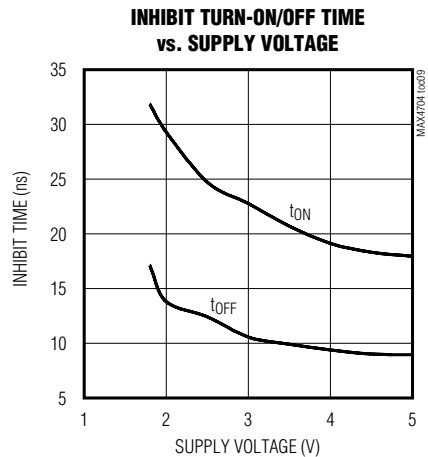
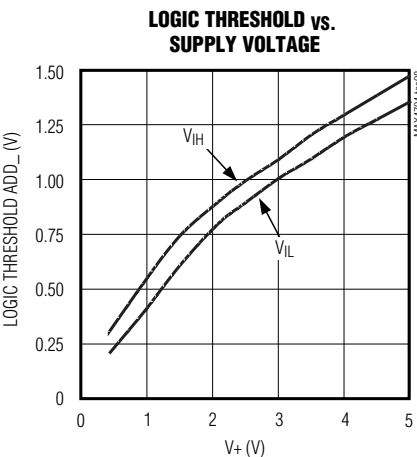
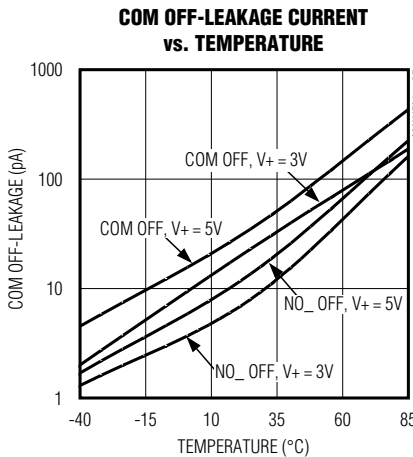
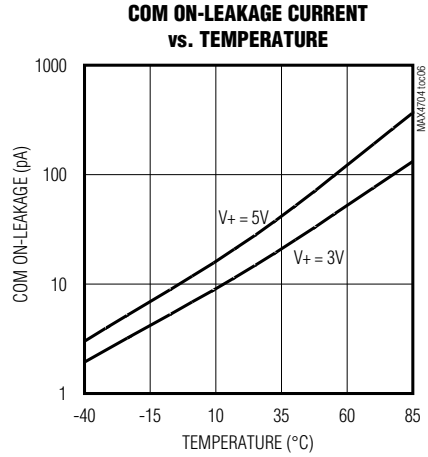
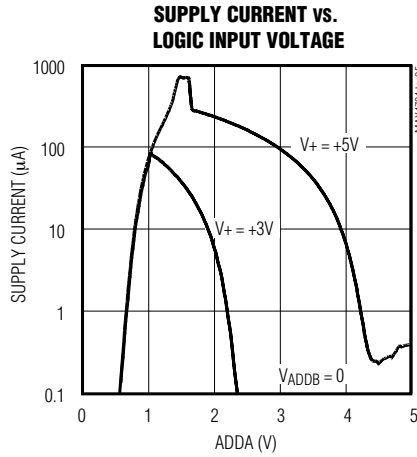
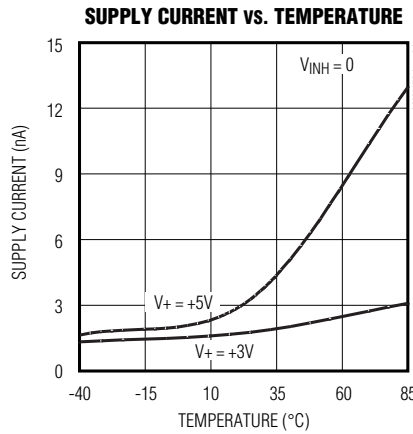
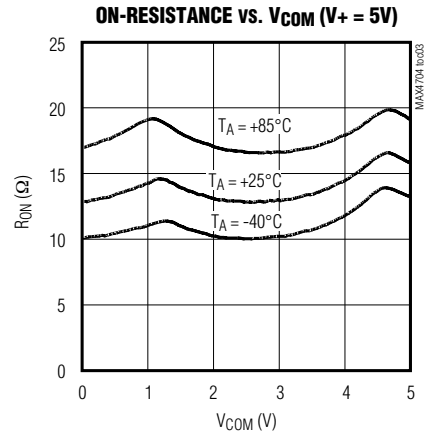
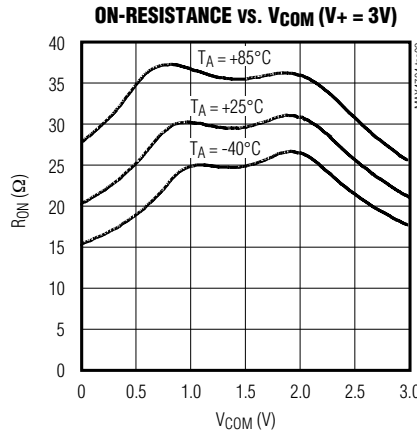
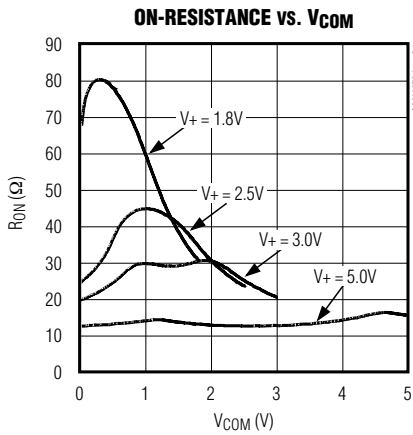

Low-Voltage, 60Ω, 4:1 Analog Multiplexer in QFN

Typical Operating Characteristics (continued)

(T_A = +25°C, unless otherwise noted.)

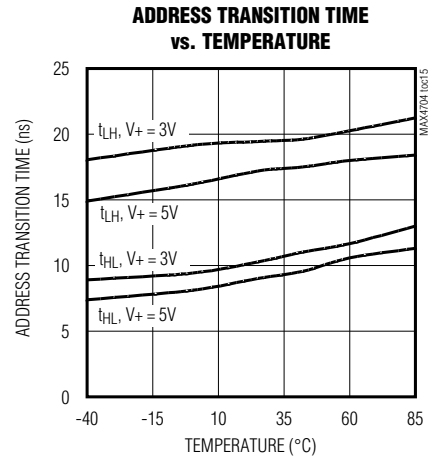
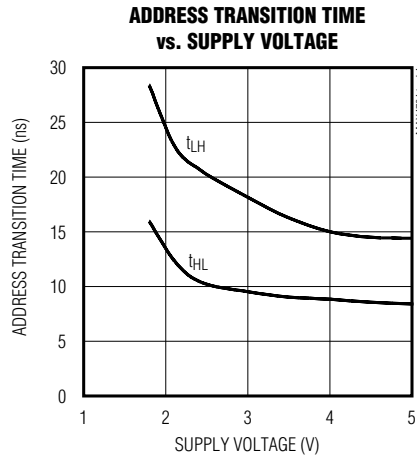
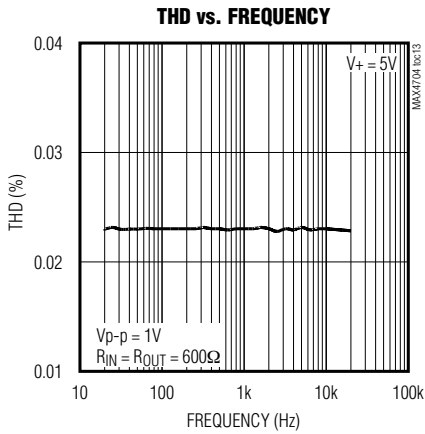
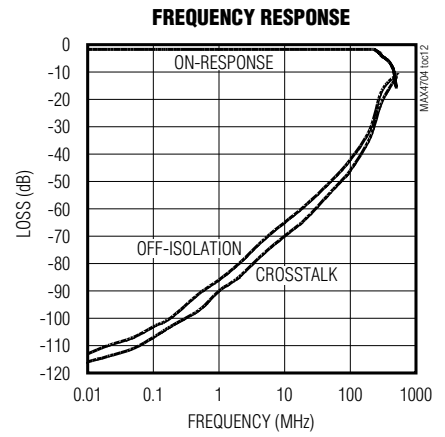
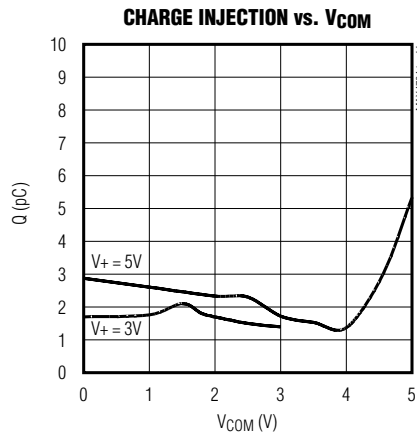
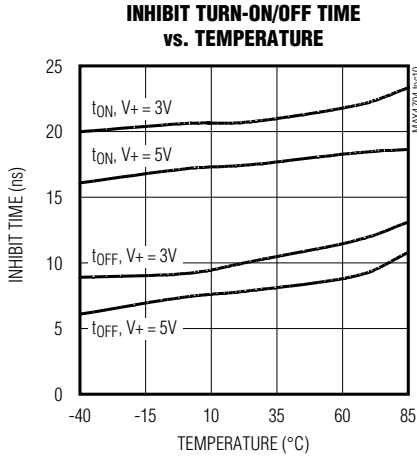

Low-Voltage, 60Ω, 4:1 Analog Multiplexer in QFN

Pin Description

PIN		NAME	FUNCTION
μMAX	QFN-EP		
10	1	V+	Positive Supply Voltage
—	2, 8	N.C.	No Connection. Not internally connected.
1	3	NO2	Analog Switch 2. Normally open.
2	4	NO3	Analog Switch 3. Normally open.
3	5	NO1	Analog Switch 1. Normally open.
4	6	INH	Inhibit. Connect to GND for normal operation. Connect to logic-level high to turn all switches off.
5	7	GND	Ground
6	9	ADDB	Address Decoder Selection B
7	10	ADDA	Address Decoder Selection A
8	11	NO0	Analog Switch 0. Normally open.
9	12	COM	Analog Switch Common Terminal
—	—	EP	Exposed Pad. Internally connected to GND. Connect to a large ground plane to maximize thermal performance; not intended as an electrical connection point (QFN package only).

MAX4704

Detailed Description

The MAX4704 low-voltage, 4-channel analog multiplexer operates from a single +1.8V to +5.5V supply. When powered from a +2.7V supply, the device has a 60Ω (max) on-resistance (R_{ON}), with 3Ω (max) R_{ON} matching and 5Ω (max) R_{ON} flatness. The digital logic inputs are +1.8V-logic compatible from a +2.7V to +3.3V supply.

Applications Information

Digital Control Inputs

The MAX4704 logic inputs are +1.8V CMOS logic compatible for 3V operation and TTL compatible for 5V operation of V+. Driving ADD_ rail-to-rail minimizes power consumption.

Analog Signal Levels

Analog signals that range over the entire supply voltage (V+ to GND) are passed with very little change in on-resistance (see *Typical Operating Characteristics*). The switches are bidirectional, so the NO_ and COM pins can be either inputs or outputs.

Power-Supply Sequencing and Overvoltage Protection

Caution: Do not exceed the absolute maximum ratings because stresses beyond those listed may cause permanent damage to devices.

Proper power-supply sequencing is recommended for all CMOS devices. Always apply V+ before applying analog signals, especially if the analog signal is not current limited. If this sequencing is not possible, and if the analog inputs are not current limited to <20mA, add a small-signal diode

(D1) as shown in Figure 1. If the analog signal can dip below GND, add D2. Adding protection diodes reduces the analog range to a diode drop (about 0.7V) below V+ (for D1), and a diode drop above ground (for D2). On-resistance increases slightly at low supply voltages. Maximum supply voltage (V+) must not exceed +6V.

Adding protection diode D2 causes the logic threshold to be shifted relative to GND. TTL compatibility is not guaranteed when D2 is added.

Protection diodes D1 and D2 also protect against some overvoltage situations. In the circuit in Figure 1, if the supply voltage is below the absolute maximum rating, and if a fault voltage up to the absolute maximum rating is applied to an analog signal pin, no damage will result.

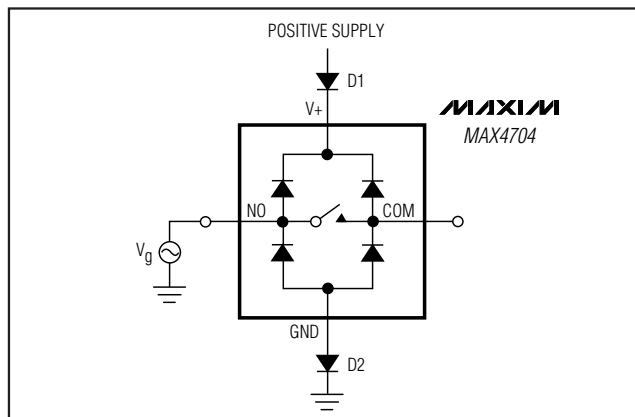

Figure 1. Overvoltage Protection Using Two External Blocking Diodes

Low-Voltage, 60Ω, 4:1 Analog Multiplexer in QFN

Test Circuits/Timing Diagrams

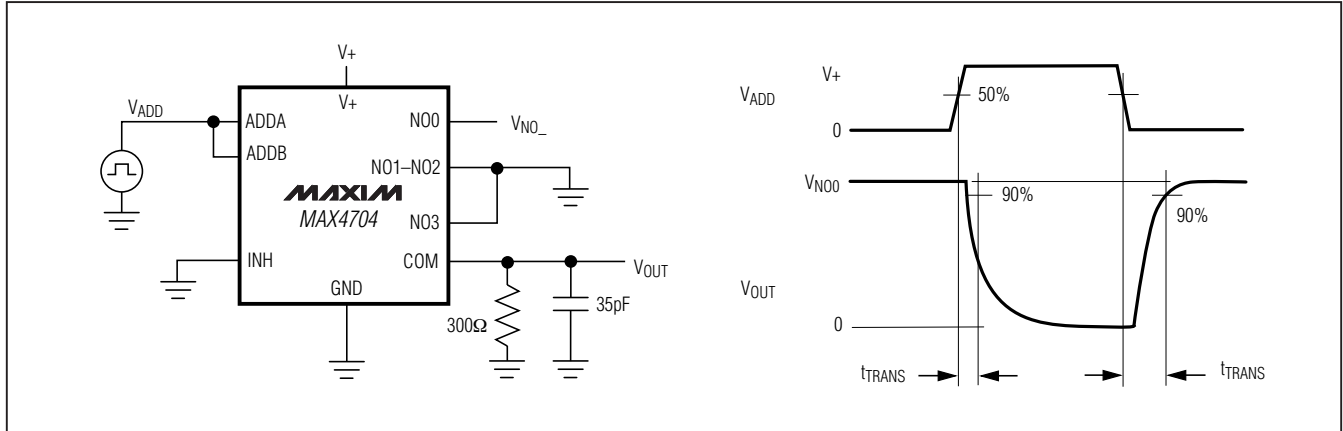

Figure 2. Address Transition Time

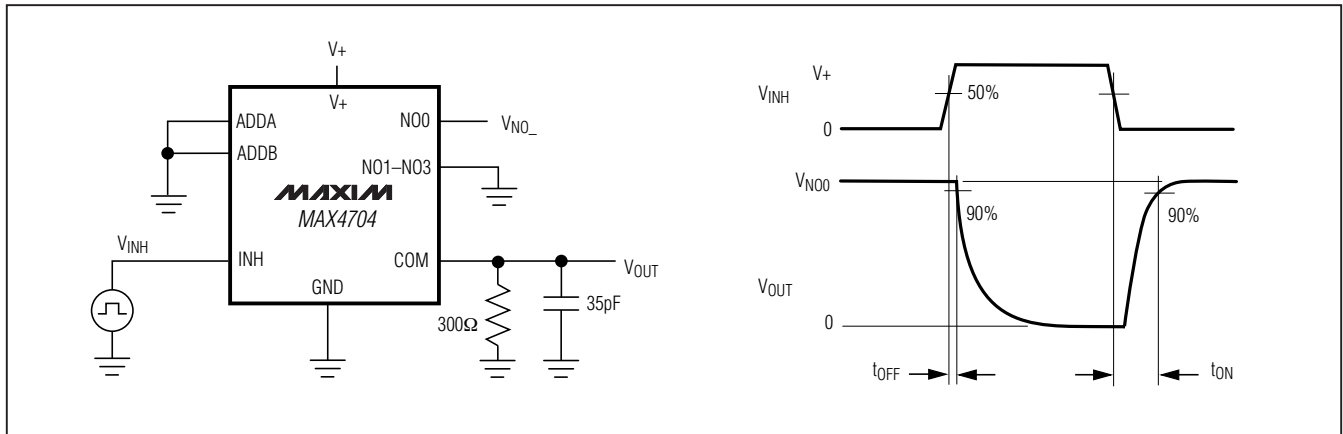

Figure 3. Inhibit Switching Times

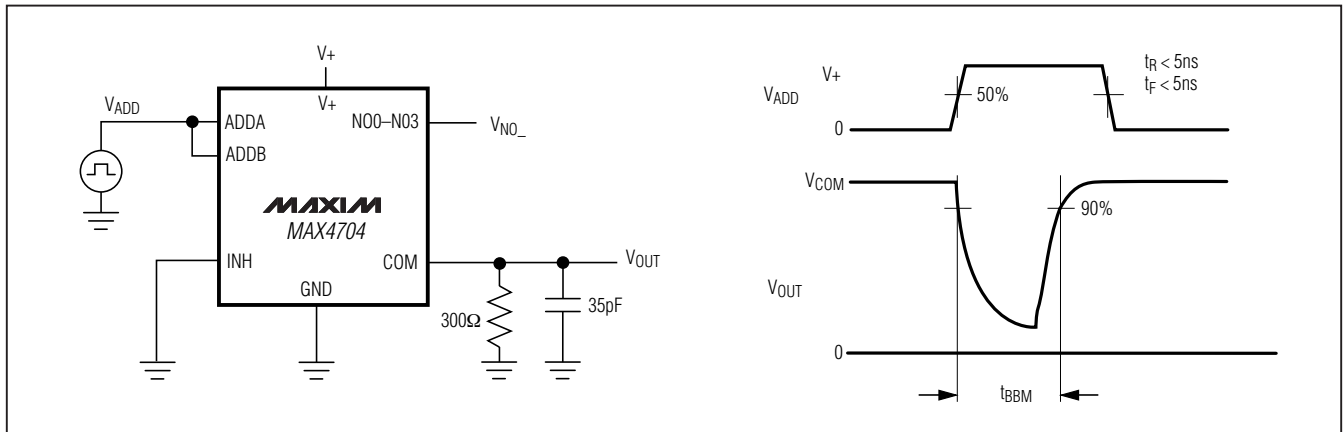

Figure 4. Break-Before-Make Interval

Low-Voltage, 60Ω, 4:1 Analog Multiplexer in QFN

Test Circuits/Timing Diagrams (continued)

MAX4704

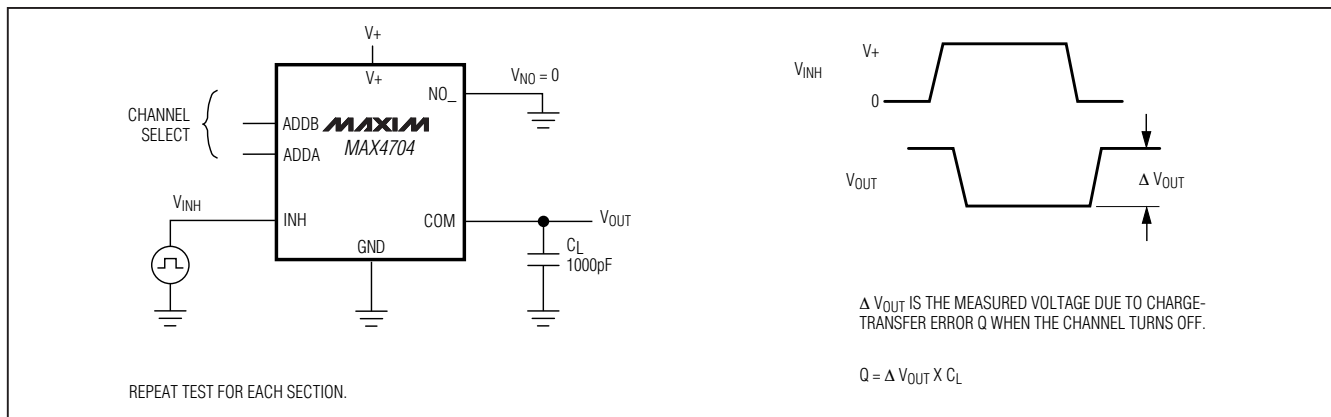

Figure 5. Charge Injection

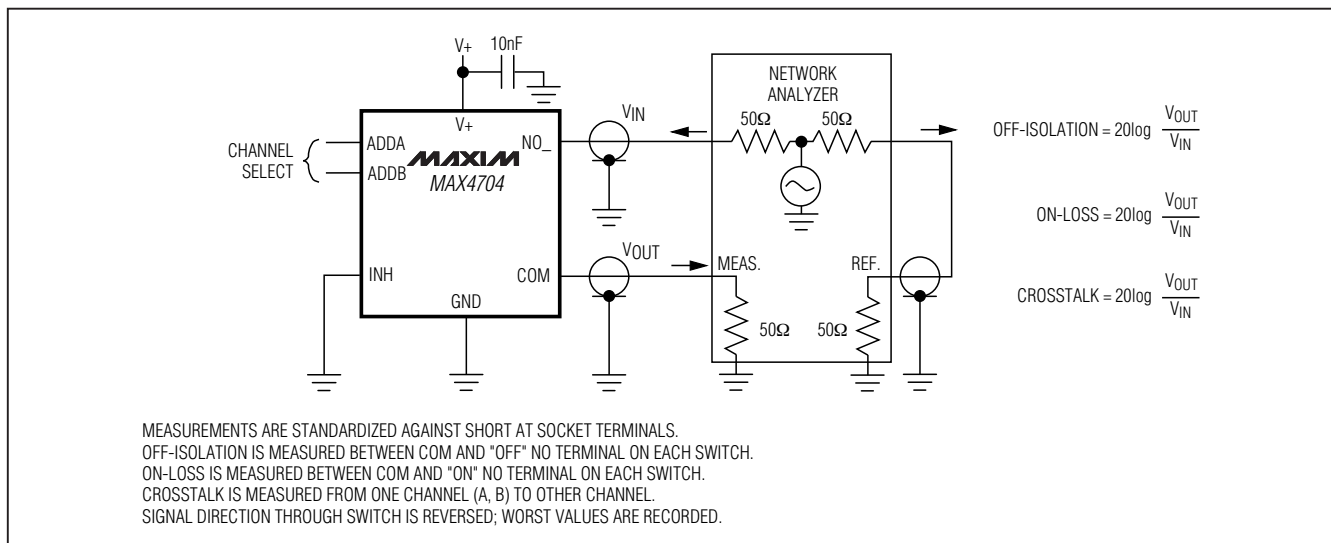

Figure 6. Off-Isolation, On-Loss, and Crosstalk

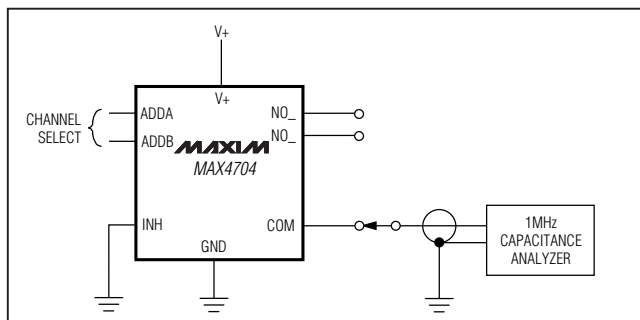

Figure 7. NO_/COM Capacitance

Chip Information

TRANSISTOR COUNT: 256

PROCESS: CMOS

Low-Voltage, 60Ω, 4:1 Analog Multiplexer in QFN

Package Information

For the latest package outline information and land patterns, go to www.maxim-ic.com/packages.

PACKAGE TYPE	PACKAGE CODE	DOCUMENT NO.
12 QFN-EP	G1233-1	21-0102
10 μMAX	—	21-0061

Low-Voltage, 60Ω, 4:1 Analog Multiplexer in QFN

Revision History

REVISION NUMBER	REVISION DATE	DESCRIPTION	PAGES CHANGED
0	10/01	Initial release	—
1	10/08	Inserted exposed paddle description	1, 7

MAX4704

Maxim cannot assume responsibility for use of any circuitry other than circuitry entirely embodied in a Maxim product. No circuit patent licenses are implied. Maxim reserves the right to change the circuitry and specifications without notice at any time.

Maxim Integrated Products, 120 San Gabriel Drive, Sunnyvale, CA 94086 408-737-7600 _____ 11

Looking for pricing, stock, or lifecycle information?

Click below to explore more details on WIN SOURCE:

- ⊖ [View MAX4704EUB+T on WIN SOURCE](#)
- ⊖ [Maxim Integrated Information](#)

Optimize Your Supply Chain with WIN SOURCE Solutions

- ✓ Global Sourcing Solution
- ✓ Obsolete Management
- ✓ Cost Control Management
- ✓ Shortage Management
- ✓ Alternative Solution
- ✓ Excess Inventory Management