



**THE DATASHEET OF  
MAX4742EUA+T**





# 0.8Ω, Low-Voltage, Single-Supply Dual SPST Analog Switches

## General Description

The MAX4741/MAX4742/MAX4743 are low on-resistance, low-voltage, dual single-pole/single-throw (SPST) analog switches that operate from a single +1.6V to +3.6V supply. These devices have fast switching speeds ( $t_{ON} = 24\text{ns}$ ,  $t_{OFF} = 16\text{ns}$  max), handle rail-to-rail analog signals, and consume less than  $1\mu\text{W}$  of quiescent power. The MAX4743 has break-before-make switching.

When powered from a +3V supply, the MAX4741/MAX4742/MAX4743 feature low  $0.8\Omega$  (max) on-resistance ( $R_{ON}$ ), with  $0.08\Omega$  (max)  $R_{ON}$  matching and  $0.18\Omega$   $R_{ON}$  flatness. The digital logic input is 1.8V CMOS compatible when using a single +3V supply.

The MAX4741 has two normally open (NO) switches, the MAX4742 has two normally closed (NC) switches, and the MAX4743 has one NO switch and one NC switch. The MAX4741 is available in 8-pin  $\mu\text{DFN}$  (2mm x 2mm), 8-pin SOT23, and 8-pin  $\mu\text{MAX}^{\text{®}}$  packages. The MAX4742/MAX4743 are available in 8-pin SOT23 and 8-pin  $\mu\text{MAX}$  packages.

## Applications

Power Routing  
 Battery Powered Systems  
 Audio and Video Signal Routing  
 Low-Voltage Data-Acquisition Systems  
 Communications Circuits  
 PCMCIA Cards  
 Cellular Phones  
 Modems  
 Hard Drives

## Features

- ◆ **Low  $R_{ON}$ :**
  - $0.8\Omega$  max (+3V Supply)**
  - $2.5\Omega$  max (+1.8V Supply)**
- ◆  **$0.18\Omega$  max  $R_{ON}$  Flatness (+3V Supply)**
- ◆ **+1.6V to +3.6V Single-Supply Operation**
- ◆ **Available in SOT23 and  $\mu\text{MAX}$  Packages**
- ◆ **High-Current Handling Capacity (150mA continuous)**
- ◆ **1.8V CMOS Logic Compatible (+3V Supply)**
- ◆ **Fast Switching:  $t_{ON} = 24\text{ns}$ ,  $t_{OFF} = 16\text{ns}$**

## Ordering Information

PART	PIN-PACKAGE	TOP MARK	PACKAGE CODE
MAX4741EKA	8 SOT23-8	AAIY	K8S-3
MAX4741EUA	8 $\mu\text{MAX}$	—	U8-1
MAX4741ELA	8 $\mu\text{DFN}$	+AAV	L822-1
MAX4742EKA	8 SOT23-8	AAIZ	K8S-3
MAX4742EUA	8 $\mu\text{MAX}$	—	U8-1
MAX4743EKA	8 SOT23-8	AAJA	K8S-3
MAX4743EUA	8 $\mu\text{MAX}$	—	U8-1

**Note:** All devices are specified over the  $-40^{\circ}\text{C}$  to  $+85^{\circ}\text{C}$  operating temperature range.

## Pin Configurations

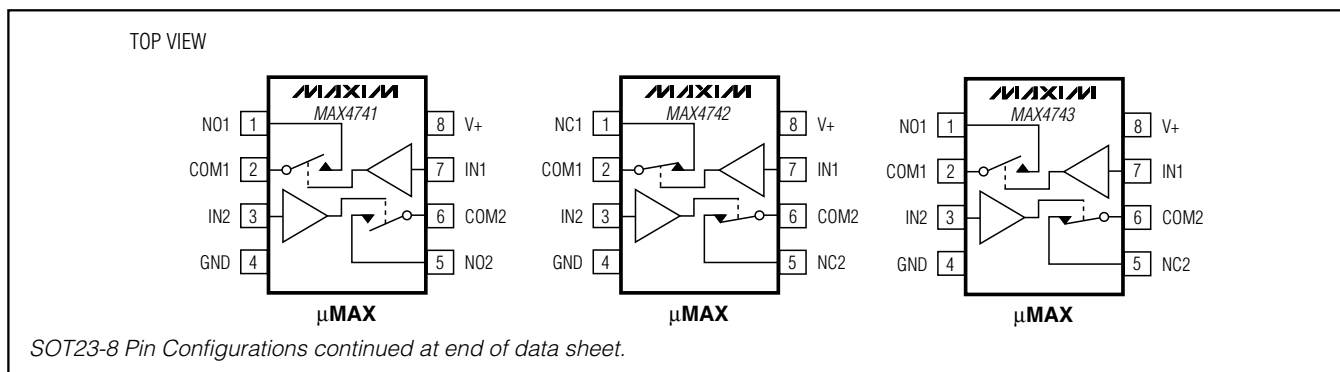

$\mu\text{MAX}$  is a registered trademark of Maxim Integrated Products, Inc.



Maxim Integrated Products 1

**For pricing, delivery, and ordering information, please contact Maxim/Dallas Direct! at 1-888-629-4642, or visit Maxim's website at [www.maxim-ic.com](http://www.maxim-ic.com).**

MAX4741/MAX4742/MAX4743

# 0.8Ω, Low-Voltage, Single-Supply Dual SPST Analog Switches

## ABSOLUTE MAXIMUM RATINGS

Voltages Referenced to GND

V+, IN_	-0.3V to +4V
COM_, NO_, NC_ (Note 1)	-0.3V to (V+ + 0.3V)
Continuous Current COM_, NO_, NC_	±150mA
Peak Current COM_, NO_, NC_ (pulsed at 1ms 10% duty cycle)	±300mA
Continuous Power Dissipation (T <sub>A</sub> = +70°C)	
8-Pin SOT23 (derate 7.52mW/°C above +70°C)	602mW
8-Pin μMAX (derate 4.5mW/°C above +70°C)	362mW

8-Pin μDFN (derate 4.8mW/°C above +70°C)	381mW
Operating Temperature Range	-40°C to +85°C
Maximum Junction Temperature	+150°C
Storage Temperature Range	-65°C to +150°C
Lead Temperature (soldering, 10s)	+300°C

**Note 1:** Signals on COM\_, NO\_, or NC\_ exceeding V+ or GND are clamped by internal diodes. Limit forward current to maximum current rating.

Stresses beyond those listed under "Absolute Maximum Ratings" may cause permanent damage to the device. These are stress ratings only, and functional operation of the device at these or any other conditions beyond those indicated in the operational sections of the specifications is not implied. Exposure to absolute maximum rating conditions for extended periods may affect device reliability.

## ELECTRICAL CHARACTERISTICS—Single +3V Supply

(V+ = +2.7V to +3.6V, V<sub>IH</sub> = +1.4V, V<sub>IL</sub> = +0.5V, T<sub>A</sub> = T<sub>MIN</sub> to T<sub>MAX</sub>, unless otherwise specified. Typical values are at V+ = +3.0V, T<sub>A</sub> = +25°C.) (Notes 2, 3)

PARAMETER	SYMBOL	CONDITIONS	T <sub>A</sub>	MIN	TYP	MAX	UNITS
<b>ANALOG SWITCH</b>							
Analog Signal Range	V <sub>COM_</sub> , V <sub>NO_</sub> , V <sub>NC_</sub>			0		V+	V
On-Resistance	R <sub>ON</sub>	V+ = 2.7V, I <sub>COM_</sub> = 100mA, V <sub>NO_</sub> or V <sub>NC_</sub> = 1.5V	+25°C		0.5	0.8	Ω
			T <sub>MIN</sub> to T <sub>MAX</sub>			0.9	
On-Resistance Match Between Channels (Note 4)	ΔR <sub>ON</sub>	V+ = 2.7V, I <sub>COM_</sub> = 100mA, V <sub>NO_</sub> or V <sub>NC_</sub> = 1.5V	+25°C		0.05	0.08	Ω
			T <sub>MIN</sub> to T <sub>MAX</sub>			0.09	
On-Resistance Flatness (Note 5)	R <sub>FLAT(ON)</sub>	V+ = 2.7V, I <sub>COM_</sub> = 100mA, V <sub>NO_</sub> or V <sub>NC_</sub> = 1V, 1.5V, 2V	+25°C		0.05	0.18	Ω
			T <sub>MIN</sub> to T <sub>MAX</sub>			0.20	
NO_ or NC_ Off-Leakage Current	I <sub>NO_(OFF)</sub> , I <sub>NC_(OFF)</sub>	V+ = 3.3V, V <sub>COM_</sub> = 0.3V, 3V, V <sub>NO_</sub> or V <sub>NC_</sub> = 3V, 0.3V	+25°C	-1		1	nA
			T <sub>MIN</sub> to T <sub>MAX</sub>		-5	5	
COM_ Off-Leakage Current	I <sub>COM_(OFF)</sub>	V+ = 3.3V, V <sub>COM_</sub> = 0.3V, 3V V <sub>NO_</sub> or V <sub>NC_</sub> = 3V, 0.3V or floating	+25°C	-1		1	nA
			T <sub>MIN</sub> to T <sub>MAX</sub>		-5	5	
COM_ On-Leakage Current	I <sub>COM_(ON)</sub>	V+ = 3.3V, V <sub>COM_</sub> = 3V, 0.3V; V <sub>NO_</sub> or V <sub>NC_</sub> = 3V, 0.3V or floating	+25°C	-2		2	nA
			T <sub>MIN</sub> to T <sub>MAX</sub>		-10	10	

# 0.8Ω, Low-Voltage, Single-Supply Dual SPST Analog Switches

MAX4741/MAX4742/MAX4743

## ELECTRICAL CHARACTERISTICS—Single +3V Supply (continued)

(V+ = +2.7V to +3.6V, V<sub>IH</sub> = +1.4V, V<sub>IL</sub> = +0.5V, T<sub>A</sub> = T<sub>MIN</sub> to T<sub>MAX</sub>, unless otherwise specified. Typical values are at V+ = +3.0V, T<sub>A</sub> = +25°C.) (Notes 2, 3)

PARAMETER	SYMBOL	CONDITIONS	T <sub>A</sub>	MIN	TYP	MAX	UNITS
<b>SWITCH DYNAMIC CHARACTERISTICS</b>							
Turn-On Time	t <sub>ON</sub>	V <sub>NO-</sub> , V <sub>NC-</sub> = 1.5V, R <sub>L</sub> = 50Ω, C <sub>L</sub> = 35pF, Figure 1	+25°C	18	24		ns
			T <sub>MIN</sub> to T <sub>MAX</sub>			28	
Turn-Off Time	t <sub>OFF</sub>	V <sub>NO-</sub> , V <sub>NC-</sub> = 1.5V, R <sub>L</sub> = 50Ω, C <sub>L</sub> = 35pF, Figure 1	+25°C	12	16		ns
			T <sub>MIN</sub> to T <sub>MAX</sub>			18	
Break-Before-Make (Note 6)	t <sub>BBM</sub>	V <sub>NO-</sub> , V <sub>NC-</sub> = 1.5V, R <sub>L</sub> = 50Ω, C <sub>L</sub> = 35pF, Figure 1 (MAX4743)	+25°C	6			ns
			T <sub>MIN</sub> to T <sub>MAX</sub>	1			
Charge Injection	Q	V <sub>GEN</sub> = 0, R <sub>GEN</sub> = 0, C <sub>L</sub> = 1.0nF, Figure 3	+25°C		28		pC
NO_ or NC_ Off-Capacitance	C <sub>OFF</sub>	f = 1MHz, Figure 4	+25°C		32		pF
COM_ Off-Capacitance	C <sub>COM_(OFF)</sub>	f = 1MHz, Figure 4	+25°C		32		pF
COM_ On-Capacitance	C <sub>COM_(ON)</sub>	f = 1MHz, Figure 4	+25°C		44		pF
-3dB On-Channel Bandwidth	BW	Signal = 0, R <sub>IN</sub> = R <sub>OUT</sub> = 50Ω, C <sub>L</sub> = 5pF, Figure 2			100		MHz
Off-Isolation (Note 7)	V <sub>ISO</sub>	f = 1MHz, V <sub>COM-</sub> = 1V <sub>RMS</sub> , R <sub>L</sub> = 50Ω, C <sub>L</sub> = 5pF, Figure 2	+25°C		-55		dB
Crosstalk (Note 8)		f = 1MHz, V <sub>COM-</sub> = 1V <sub>RMS</sub> , R <sub>L</sub> = 50Ω, C <sub>L</sub> = 5pF, Figure 2	+25°C		-110		dB
Total Harmonic Distortion	THD	f = 20Hz to 20kHz, V <sub>COM-</sub> = 2V <sub>p-p</sub> , R <sub>L</sub> = 32Ω	+25°C		0.02		%
<b>LOGIC INPUT</b>							
Input Logic High	V <sub>IH</sub>			1.4			V
Input Logic Low	V <sub>IL</sub>					0.5	V
Input Leakage Current	I <sub>IN</sub>	V <sub>IN-</sub> = 0 or V+		-1	0.005	1	μA
<b>POWER SUPPLY</b>							
Power-Supply Range	V+			1.6		3.6	V
Positive Supply Current	I+	V+ = 3.6V, V <sub>IN-</sub> = 0 or V+, all channels on or off	+25°C			0.2	μA

# 0.8Ω, Low-Voltage, Single-Supply Dual SPST Analog Switches

## ELECTRICAL CHARACTERISTICS—Single +1.8V Supply

(V<sub>+</sub> = +1.8V, V<sub>IH</sub> = +1.0V, V<sub>IL</sub> = 0.4V, T<sub>A</sub> = T<sub>MIN</sub> to T<sub>MAX</sub>, unless otherwise specified. Typical values are at T<sub>A</sub> = +25°C.) (Notes 2, 3)

PARAMETER	SYMBOL	CONDITIONS	T <sub>A</sub>	MIN	TYP	MAX	UNITS
<b>ANALOG SWITCH</b>							
Analog Signal Range	V <sub>COM_</sub> , V <sub>NO_</sub> , V <sub>NC_</sub>			0		V <sub>+</sub>	V
On-Resistance	R <sub>ON</sub>	I <sub>COM_</sub> = 10mA, V <sub>NO_</sub> or V <sub>NC_</sub> = 0.9V	+25°C	1.3	2.5		Ω
			T <sub>MIN</sub> to T <sub>MAX</sub>		5		
NO_ or NC_ Off-Leakage Current	I <sub>NO_(OFF)</sub> , I <sub>NC_(OFF)</sub>	V <sub>COM_</sub> = 0.3V, 1.5V; V <sub>NO_</sub> or V <sub>NC_</sub> = 1.5V, 0.3V	+25°C	-1	1		nA
			T <sub>MIN</sub> to T <sub>MAX</sub>	-5	5		
COM_ Off-Leakage Current	I <sub>COM_(OFF)</sub>	V <sub>COM_</sub> = 0.3V, 1.5V; V <sub>NO_</sub> or V <sub>NC_</sub> = 1.5V, 0.3V	+25°C	-1	1		nA
			T <sub>MIN</sub> to T <sub>MAX</sub>	-5	5		
COM_ On-Leakage Current	I <sub>COM_(ON)</sub>	V <sub>COM_</sub> = 0.3V, 1.5V, V <sub>NO_</sub> or V <sub>NC_</sub> = 0.3V, 1.5V, or floating	+25°C	-2	2		nA
			T <sub>MIN</sub> to T <sub>MAX</sub>	-10	10		
<b>SWITCH DYNAMIC CHARACTERISTICS</b>							
Turn-On Time	t <sub>ON</sub>	V <sub>NO_</sub> , V <sub>NC_</sub> = 1.5V, R <sub>L</sub> = 50Ω, C <sub>L</sub> = 35pF, Figure 1	+25°C	25	35		ns
			T <sub>MIN</sub> to T <sub>MAX</sub>		40		
Turn-Off Time	t <sub>OFF</sub>	V <sub>NO_</sub> , V <sub>NC_</sub> = 1.5V, R <sub>L</sub> = 50Ω, C <sub>L</sub> = 35pF, Figure 1	+25°C	16	25		ns
			T <sub>MIN</sub> to T <sub>MAX</sub>		30		
Break-Before-Make (Note 6)	t <sub>BBM</sub>	V <sub>NO_</sub> , V <sub>NC_</sub> = 1.5V, R <sub>L</sub> = 50Ω, C <sub>L</sub> = 35pF, Figure 1 (MAX4743)	+25°C	10			ns
			T <sub>MIN</sub> to T <sub>MAX</sub>	1			
Charge Injection	Q	V <sub>GEN</sub> = 0, R <sub>GEN</sub> = 0, C <sub>L</sub> = 1nF, Figure 2	+25°C		16		pC
Off-Isolation (Note 7)	V <sub>ISO</sub>	f = 1MHz, V <sub>NO_</sub> = V <sub>NC_</sub> = 1V <sub>RMS</sub> , R <sub>L</sub> = 50Ω, C <sub>L</sub> = 5pF, Figure 2	+25°C		-50		dB
Crosstalk (Note 8)		f = 1MHz, V <sub>COM_</sub> = 1V <sub>RMS</sub> , R <sub>L</sub> = 50Ω, C <sub>L</sub> = 5pF, Figure 2	+25°C		-110		dB

# 0.8Ω, Low-Voltage, Single-Supply Dual SPST Analog Switches

## ELECTRICAL CHARACTERISTICS—Single +1.8V Supply (continued)

(V+ = +1.8V, V<sub>IH</sub> = +1.0V, V<sub>IL</sub> = 0.4V, T<sub>A</sub> = T<sub>MIN</sub> to T<sub>MAX</sub>, unless otherwise specified. Typical values are at T<sub>A</sub> = +25°C.) (Notes 2, 3)

PARAMETER	SYMBOL	CONDITIONS	T <sub>A</sub>	MIN	TYP	MAX	UNITS
<b>LOGIC INPUT</b>							
Input Logic High	V <sub>IH</sub>			1			V
Input Logic Low	V <sub>IL</sub>					0.4	V
Input Leakage Current	I <sub>IN</sub>	V <sub>INL</sub> = 0 or V+		-1		1	μA

**Note 2:** The algebraic convention, where the most negative value is a minimum and the most positive value is a maximum, is used in this data sheet.

**Note 3:** μDFN and SOT23 packaged parts are 100% tested at +25°C. Limits across the full temperature range are guaranteed by design and correlation. μMAX packaged parts -40°C specifications are guaranteed by design.

**Note 4:** ΔR<sub>ON</sub> = R<sub>ON</sub>(MAX) - R<sub>ON</sub>(MIN).

**Note 5:** Flatness is defined as the difference between the maximum and the minimum value of on-resistance as measured over the specified analog signal ranges.

**Note 6:** Guaranteed by design.

**Note 7:** Off-Isolation = 20log<sub>10</sub>(V<sub>COML</sub>/V<sub>NO-</sub>), V<sub>COML</sub> = output, V<sub>NO-</sub> = input to off switch.

**Note 8:** Between two switches.

## Typical Operating Characteristics

(T<sub>A</sub> = +25°C, unless otherwise noted.)

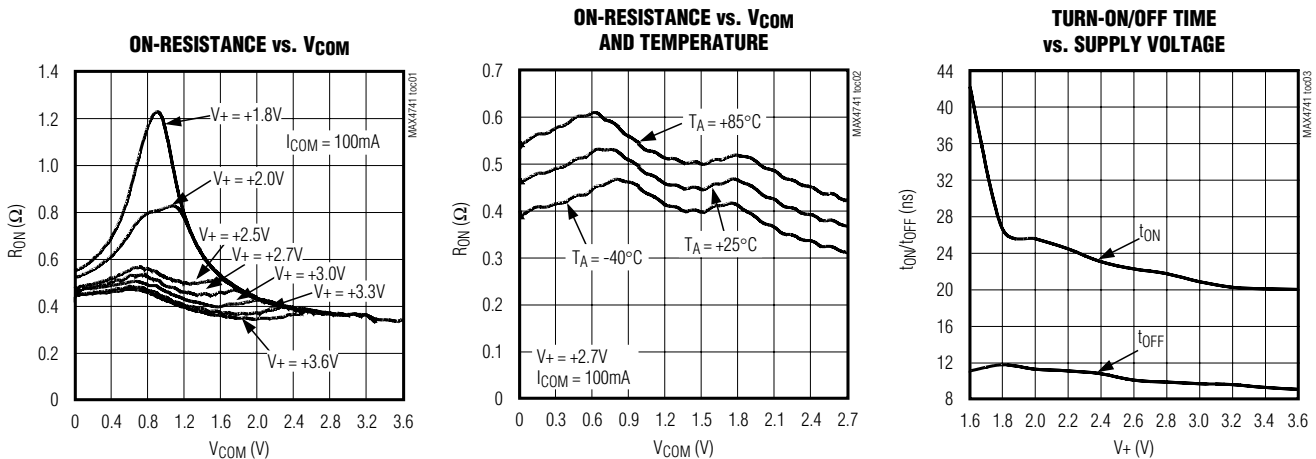

# 0.8Ω, Low-Voltage, Single-Supply Dual SPST Analog Switches

## Typical Operating Characteristics (continued)

(T<sub>A</sub> = +25°C, unless otherwise noted.)

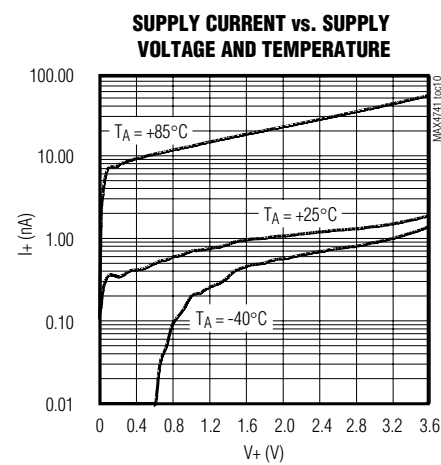
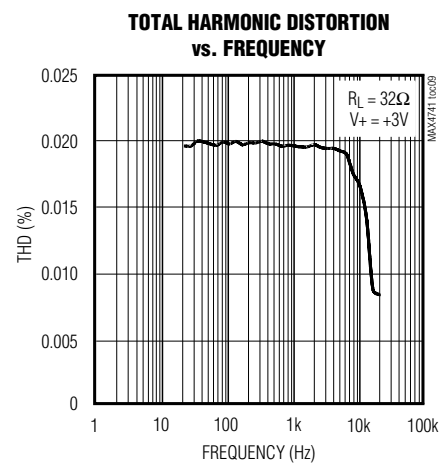
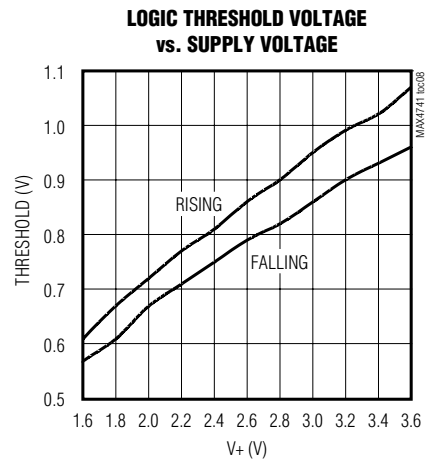
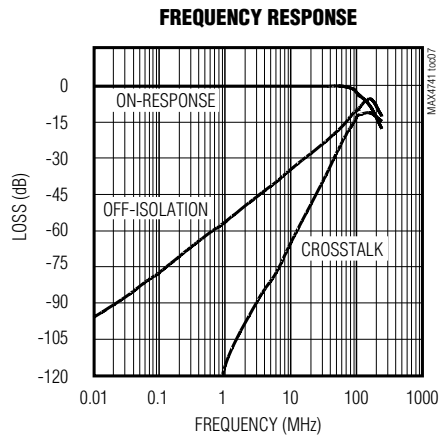
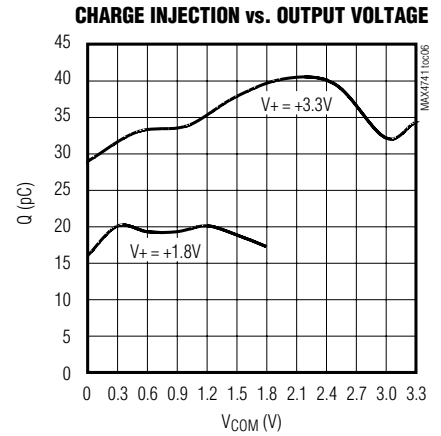
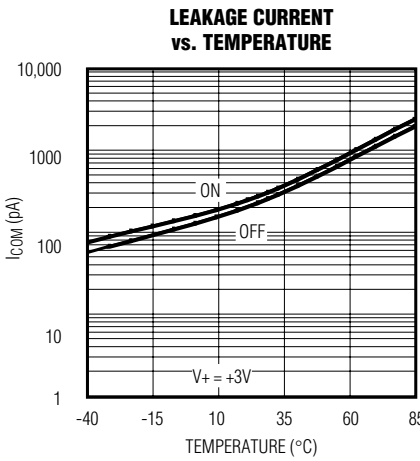
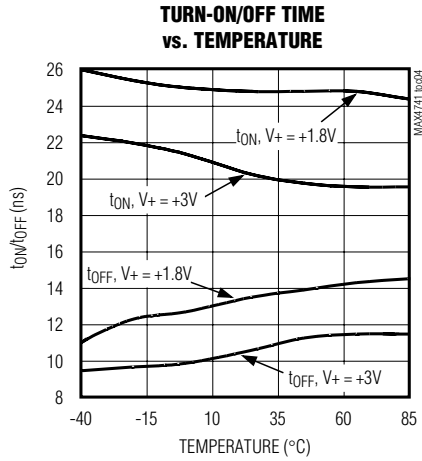

# 0.8Ω, Low-Voltage, Single-Supply Dual SPST Analog Switches

## Pin Description

PIN						NAME	FUNCTION
MAX4741		MAX4742		MAX4743			
μMAX/μDFN	SOT23-8	μMAX	SOT23-8	μMAX	SOT23-8		
1	8	—	—	1	8	NO1	Analog Switch 1 Normally Open
—	—	1	8	—	—	NC1	Analog Switch 1 Normally Closed
2	7	2	7	2	7	COM1	Analog Switch 1 Common
3	6	3	6	3	6	IN2	Logic Control Input Switch 2
4	5	4	5	4	5	GND	Ground
5	3	—	—	—	—	NO2	Analog Switch 2 Normally Open
—	—	5	3	5	3	NC2	Analog Switch 2 Normally Closed
6	4	6	4	6	4	COM2	Analog Switch 2 Common
7	1	7	1	7	1	IN1	Logic Control Input Switch 1
8	2	8	2	8	2	V+	Positive Supply Voltage

### Detailed Description

The MAX4741/MAX4742/MAX4743 are low 0.8Ω max (at V+ = +3V) on-resistance, low-voltage, dual analog switches that operate from a +1.6V to +3.6V single supply. CMOS switch construction allows switching analog signals that are within the supply voltage range (GND to V+).

When powered from a +3V supply, the 0.8Ω max R<sub>ON</sub> allows high continuous currents to be switched in a variety of applications.

### Applications Information

Proper power-supply sequencing is recommended for all CMOS devices. Do not exceed the absolute maximum ratings, because stresses beyond the listed ratings can cause permanent damage to the devices. Always sequence V+ on first, followed by NO\_, NC\_, or COM\_.

Although it is not required, power-supply bypassing improves noise margin and prevents switching noise propagation from the V+ supply to other components. A 0.1μF capacitor, connected from V+ to GND, is adequate for most applications.

### Logic Inputs

The MAX4741/MAX4742/MAX4743 logic inputs can be driven up to +3.6V regardless of the supply voltage. For example, with a +1.8V supply, IN\_ may be driven low to GND and high to +3.6V. Driving IN\_ rail-to-rail minimizes power consumption.

### Analog Signal Levels

Analog signals that range over the entire supply voltage (V+ to GND) can be passed with very little change in on-resistance (see *Typical Operating Characteristics*). The switches are bidirectional, so the NO\_, NC\_, and COM\_ pins can be used as either inputs or outputs.

### Layout

High-speed switches require proper layout and design procedures for optimum performance. Reduce stray inductance and capacitance by keeping traces short and wide. Ensure that bypass capacitors are as close to the device as possible. Use large ground planes where possible.

MAX4741/MAX4742/MAX4743

# 0.8Ω, Low-Voltage, Single-Supply Dual SPST Analog Switches

## Test Circuits/Timing Diagrams

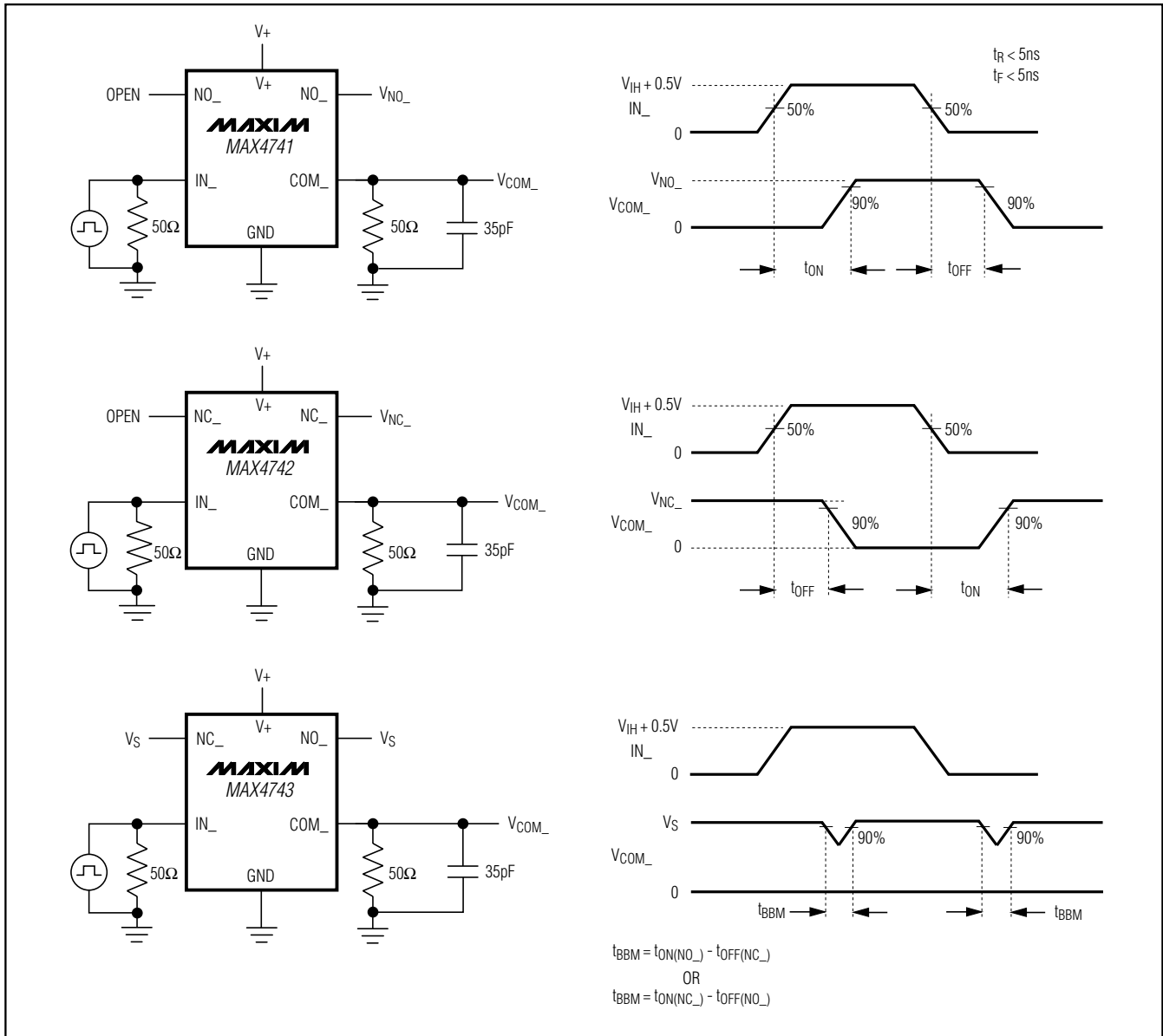

Figure 1. Switching Times

# 0.8Ω, Low-Voltage, Single-Supply Dual SPST Analog Switches

## Test Circuits/Timing Diagrams (continued)

MAX4741/MAX4742/MAX4743

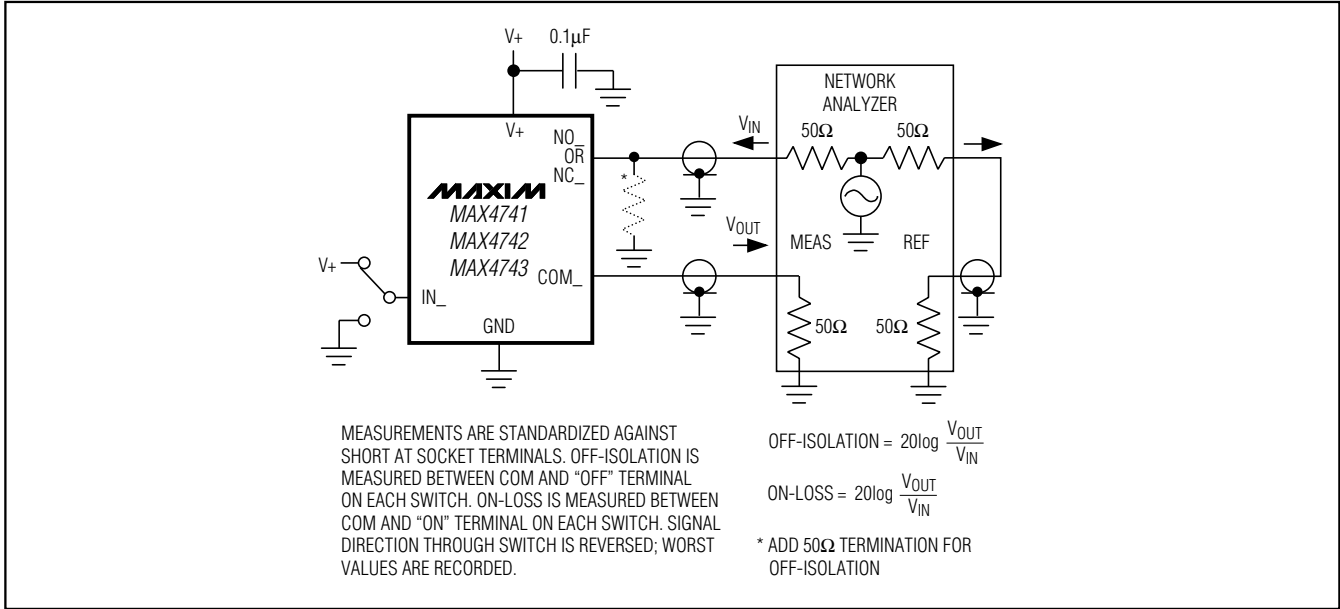

Figure 2. Off-Isolation, On-Loss, and Crosstalk

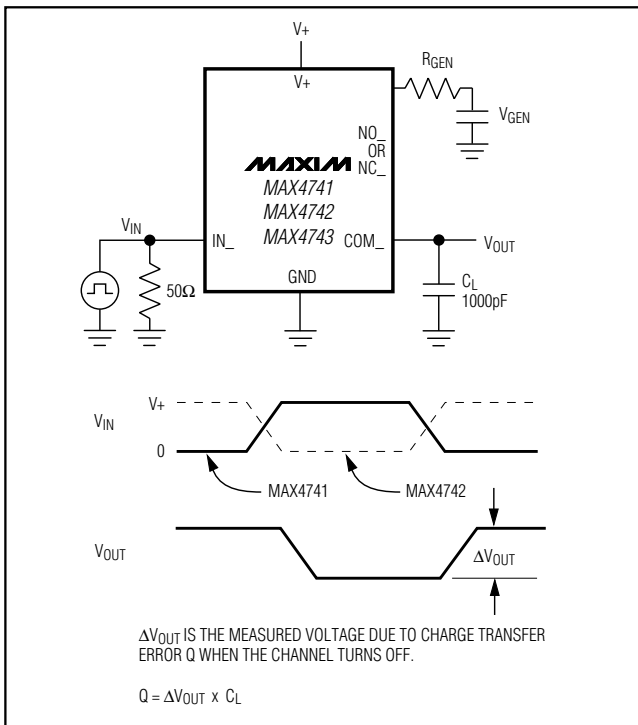

Figure 3. Charge Injection

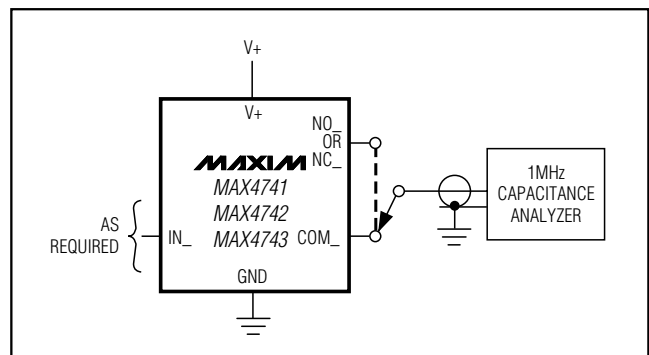
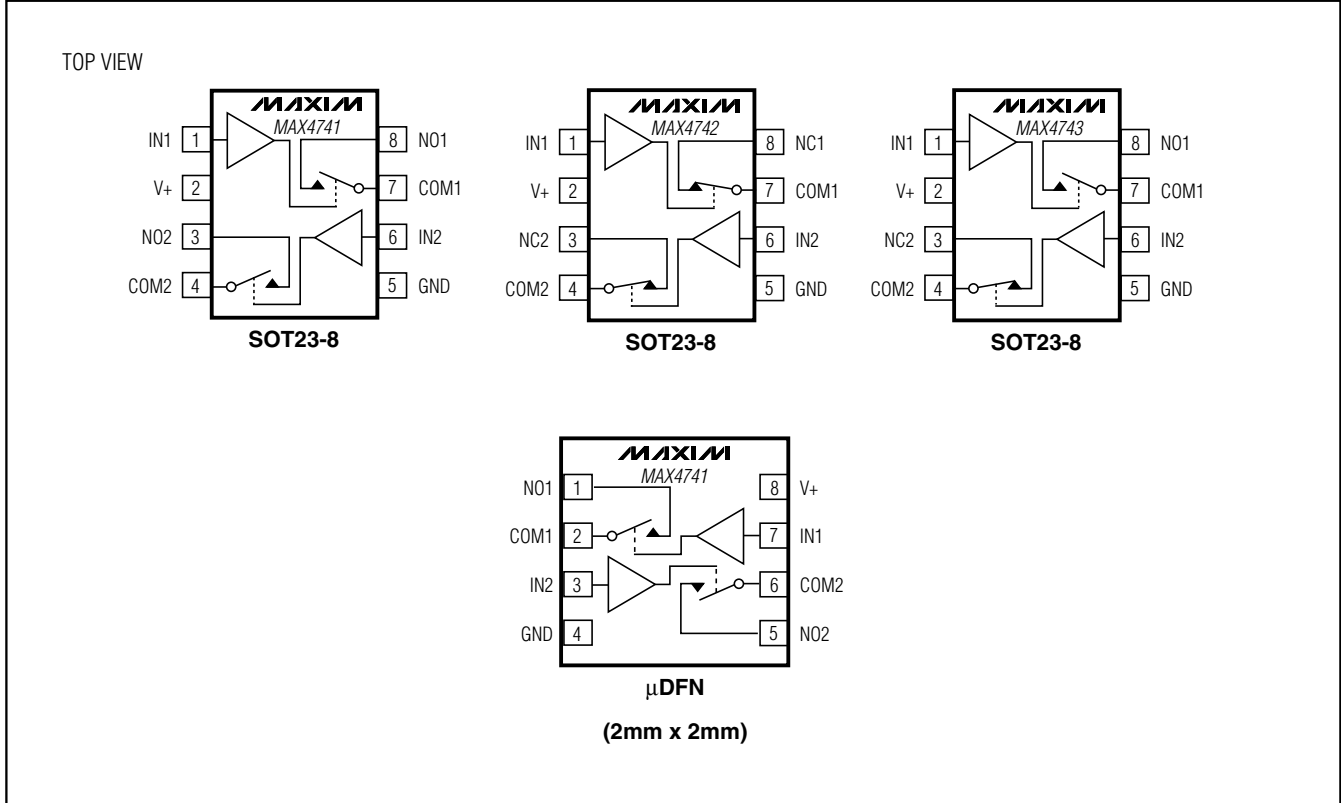

Figure 4. NO\_, NC\_, and COM\_ Capacitance

# 0.8Ω, Low-Voltage, Single-Supply Dual SPST Analog Switches

## Pin Configurations (continued)



### Chip Information

TRANSISTOR COUNT = 121

PROCESS = CMOS

# 0.8Ω, Low-Voltage, Single-Supply Dual SPST Analog Switches

## Package Information

(The package drawing(s) in this data sheet may not reflect the most current specifications. For the latest package outline information, go to [www.maxim-ic.com/packages](http://www.maxim-ic.com/packages).)

MAX4741/MAX4742/MAX4743

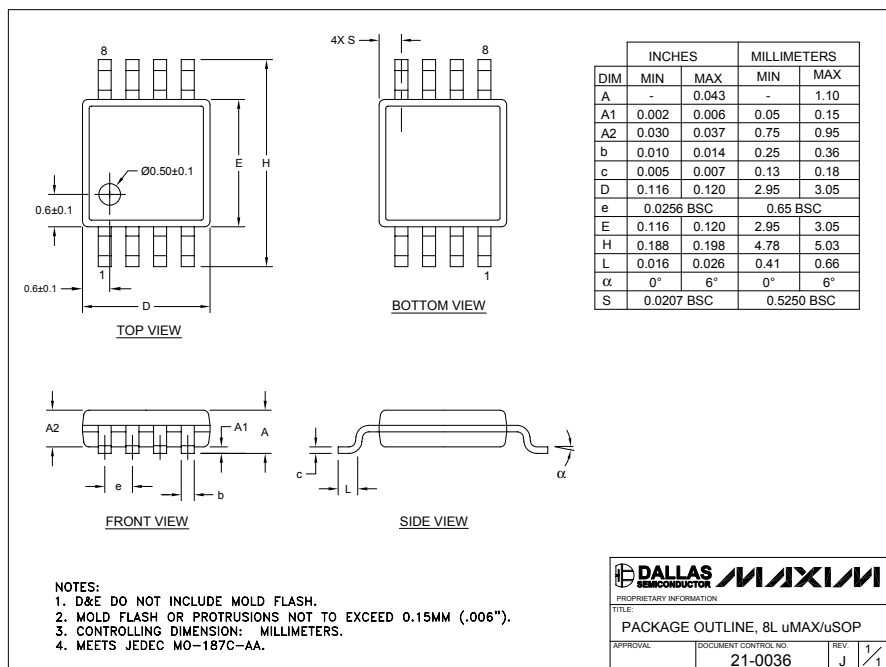
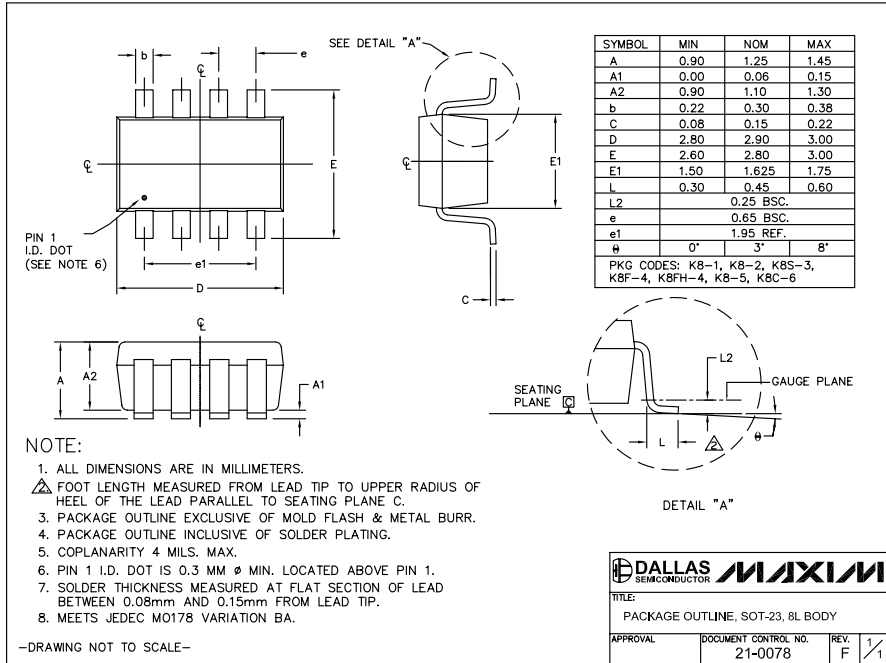

# 0.8Ω, Low-Voltage, Single-Supply Dual SPST Analog Switches

## Package Information (continued)

(The package drawing(s) in this data sheet may not reflect the most current specifications. For the latest package outline information, go to [www.maxim-ic.com/packages](http://www.maxim-ic.com/packages).)

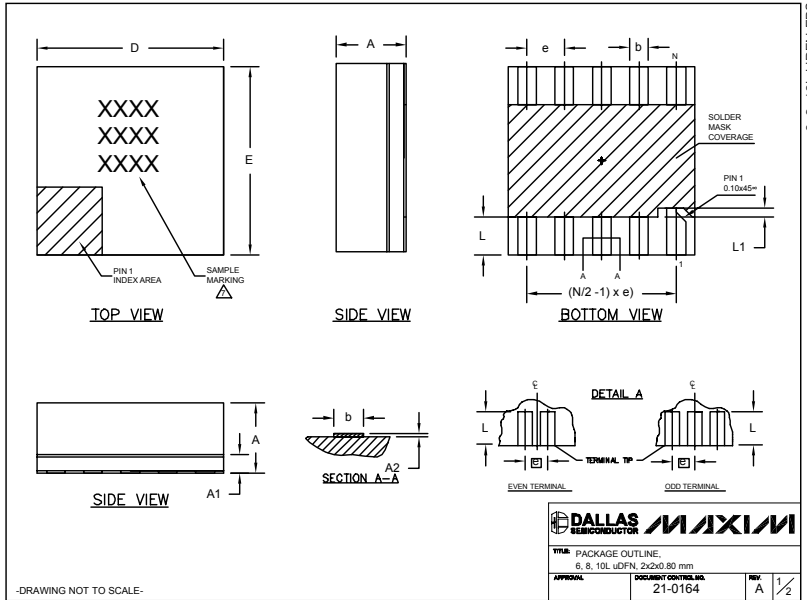

COMMON DIMENSIONS			
SYMBOL	MIN.	NOM.	MAX.
A	0.70	0.75	0.80
A1	0.15	0.20	0.25
A2	0.020	0.025	0.035
D	1.95	2.00	2.05
E	1.95	2.00	2.05
L	0.30	0.40	0.50
L1	0.10 REF.		

PACKAGE VARIATIONS				
PKG. CODE	N	e	b	(N/2 - 1) x e
L622-1	6	0.65 BSC	0.30±0.05	1.30 REF.
L822-1	8	0.50 BSC	0.25±0.05	1.50 REF.
L1022-1	10	0.40 BSC	0.20±0.03	1.60 REF.

NOTES:

- ALL DIMENSIONS ARE IN mm, ANGLES IN DEGREES.
- COPLANARITY SHALL NOT EXCEED 0.08mm.
- WARPAGE SHALL NOT EXCEED 0.10mm.
- PACKAGE LENGTH/PACKAGE WIDTH ARE CONSIDERED AS SPECIAL CHARACTERISTIC(S).
- "N" IS THE TOTAL NUMBER OF LEADS.
- NUMBER OF LEADS SHOWN ARE FOR REFERENCE ONLY.
- △ MARKING IS FOR PACKAGE ORIENTATION REFERENCE ONLY.

DALLAS SEMICONDUCTOR MAXIM			
PACKAGE OUTLINE	DOCUMENT CONTROL	REV	
6, 8, 10L UDFN, 2x2x0.80 mm	21-0164	A	1/2

## Revision History

Pages changed at Rev 2: 1, 12

Maxim cannot assume responsibility for use of any circuitry other than circuitry entirely embodied in a Maxim product. No circuit patent licenses are implied. Maxim reserves the right to change the circuitry and specifications without notice at any time.

12 \_\_\_\_\_ Maxim Integrated Products, 120 San Gabriel Drive, Sunnyvale, CA 94086 408-737-7600

## Looking for pricing, stock, or lifecycle information?

Click below to explore more details on WIN SOURCE:

- ⊖ [View MAX4742EUA+T on WIN SOURCE](#)
- ⊖ [Maxim Integrated Information](#)

## Optimize Your Supply Chain with WIN SOURCE Solutions

- ✓ Global Sourcing Solution
- ✓ Obsolete Management
- ✓ Cost Control Management
- ✓ Shortage Management
- ✓ Alternative Solution
- ✓ Excess Inventory Management